



Chipsmall Limited consists of a professional team with an average of over 10 year of expertise in the distribution of electronic components. Based in Hongkong, we have already established firm and mutual-benefit business relationships with customers from,Europe,America and south Asia,supplying obsolete and hard-to-find components to meet their specific needs.

With the principle of “Quality Parts,Customers Priority,Honest Operation,and Considerate Service”,our business mainly focus on the distribution of electronic components. Line cards we deal with include Microchip,ALPS,ROHM,Xilinx,Pulse,ON,Everlight and Freescale. Main products comprise IC,Modules,Potentiometer,IC Socket,Relay,Connector.Our parts cover such applications as commercial,industrial, and automotives areas.

We are looking forward to setting up business relationship with you and hope to provide you with the best service and solution. Let us make a better world for our industry!



## Contact us

Tel: +86-755-8981 8866 Fax: +86-755-8427 6832

Email & Skype: info@chipsmall.com Web: www.chipsmall.com

Address: A1208, Overseas Decoration Building, #122 Zhenhua RD., Futian, Shenzhen, China



## Two-Phase Multiphase Buck PWM Controller with Integrated MOSFET Drivers

The ISL6563 two-phase PWM control IC provides a precision voltage regulation system for advanced microprocessors. Multiphase power conversion is a marked departure from single phase converter configurations employed to satisfy the increasing current demands of modern microprocessors and other electronic circuits. By distributing the power and load current, implementation of multiphase converters utilize smaller and lower cost transistors with fewer input and output capacitors. These reductions accrue from the higher effective conversion frequency with higher frequency ripple current due to the phase interleaving process of this topology.

Outstanding features of this controller IC include programmable VID codes compatible with Intel VRM9, VRM10, as well as AMD's Hammer microprocessors, along with a system regulation accuracy of  $\pm 1\%$ . The droop characteristic, used to reduce the overshoot or undershoot of the output voltage, is easily programmed with a single resistor.

Important features of this controller IC include a set of sophisticated overvoltage and overcurrent protection. Overvoltage results in the converter turning the lower MOSFETs ON to clamp the rising output voltage and protect the microprocessor. Like other Intersil multiphase controllers, the ISL6563 uses cost and space-saving  $r_{DS(ON)}$  sensing for channel current balance, dynamic voltage positioning, and overcurrent protection. Channel current balancing is automatic and accurate with the integrated current-balance control system. Overcurrent protection can be tailored to any application with no need for additional parts. These features provide advanced protection for the microprocessor and power system.

### Ordering Information

PART NUMBER (Note 2)	PART MARKING	TEMP. RANGE (°C)	PACKAGE (Pb-free)	PKG. DWG. #
ISL6563CRZ	65 63CRZ	0 to +70	24 Ld 4x4 QFN	L24.4x4B
ISL6563CRZ-T (Note 1)	65 63CRZ	0 to +70	24 Ld 4x4 QFN	L24.4x4B
ISL6563CRZ-TK (Note 1)	65 63CRZ	0 to +70	24 Ld 4x4 QFN	L24.4x4B
ISL6563IRZ	65 63IRZ	-40 to +85	24 Ld 4x4 QFN	L24.4x4B
ISL6563IRZ-T (Note 1)	65 63IRZ	-40 to +85	24 Ld 4x4 QFN	L24.4x4B
ISL6563EVAL1	Evaluation Platform			

#### NOTES:

- Please refer to [TB347](#) for details on reel specifications.
- These Intersil Pb-free plastic packaged products employ special Pb-free material sets, molding compounds/die attach materials, and 100% matte tin plate plus anneal (e3 termination finish, which is RoHS compliant and compatible with both SnPb and Pb-free soldering operations). Intersil Pb-free products are MSL classified at Pb-free peak reflow temperatures that meet or exceed the Pb-free requirements of IPC/JEDEC J STD-020.

### Features

- Integrated Two-Phase Power Conversion
- Both 5V and 12V Conversion
- Precision Channel Current Sharing
  - Loss Less Current Sampling - Uses  $r_{DS(ON)}$
- Precision Output Voltage Regulation
  - $\pm 1\%$  System Accuracy Over-Temperature (Commercial)
- Microprocessor Voltage Identification Inputs
  - Up to a 6-Bit DAC
  - Selectable between Intel's VRM9, VRM10, or AMD's Hammer DAC codes
  - Resistor-Programmable Droop Voltage
- Fast Transient Recovery Time
- Overcurrent Protection
- Improved, Multi-tiered Overvoltage Protection
- Capable of Start-up into a Pre-Charged Output
- QFN Package:
  - Compliant to JEDEC PUB95 MO-220 QFN - Quad Flat No Leads - Package Outline
  - Near Chip Scale Package Footprint, which Improves PCB Efficiency and has a Thinner Profile
- Pb-Free (RoHS Compliant)

### Pinout

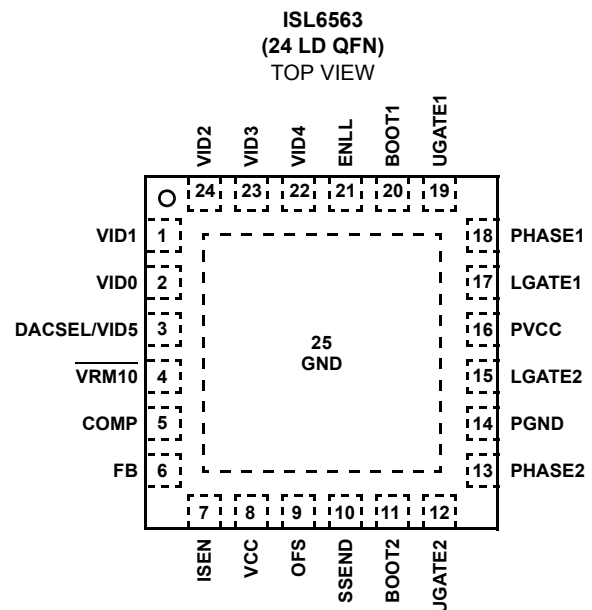

# Block Diagram

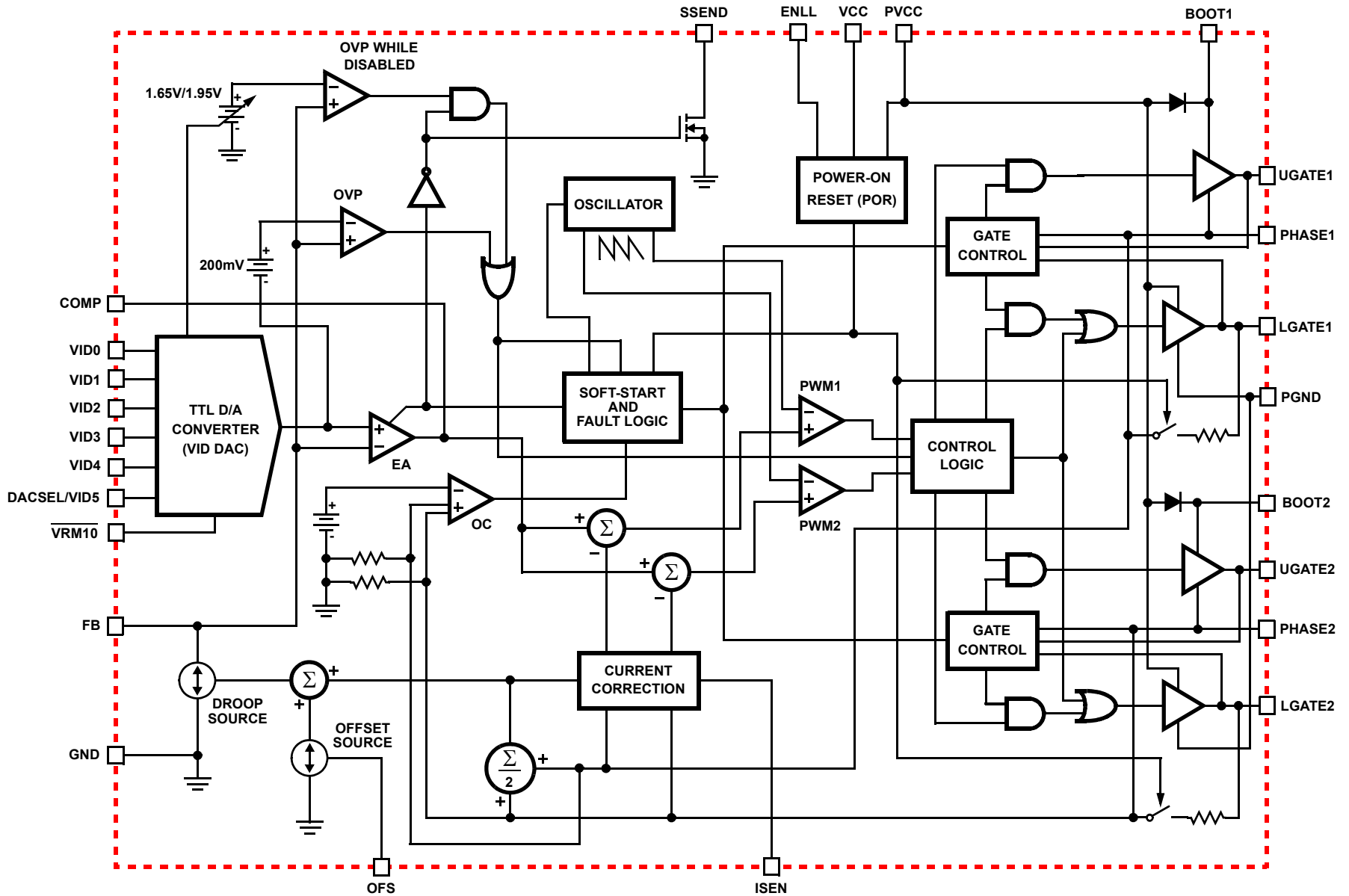

ISL6563

**Simplified Power System Diagram**

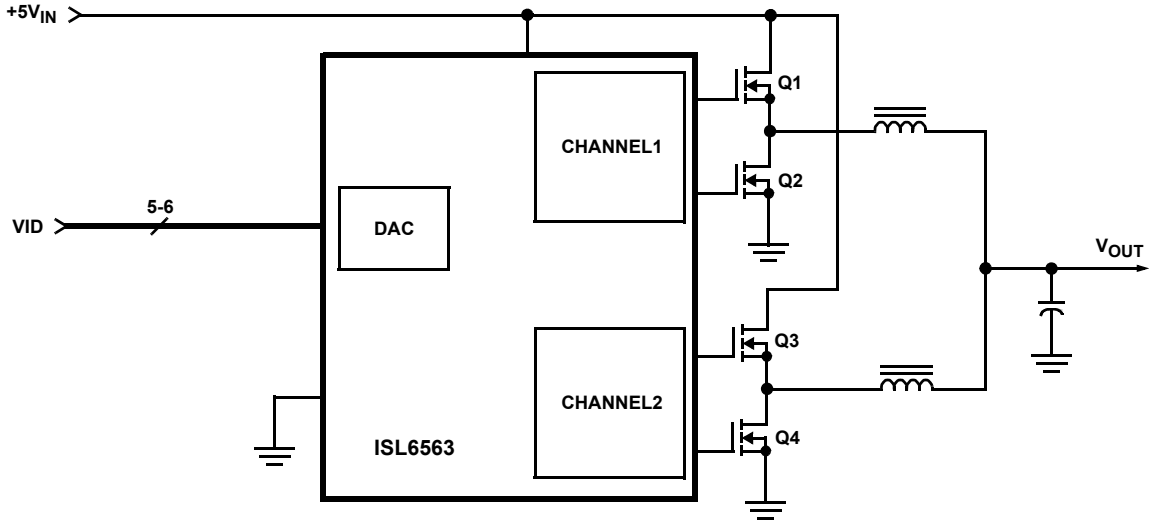

**Typical Application**

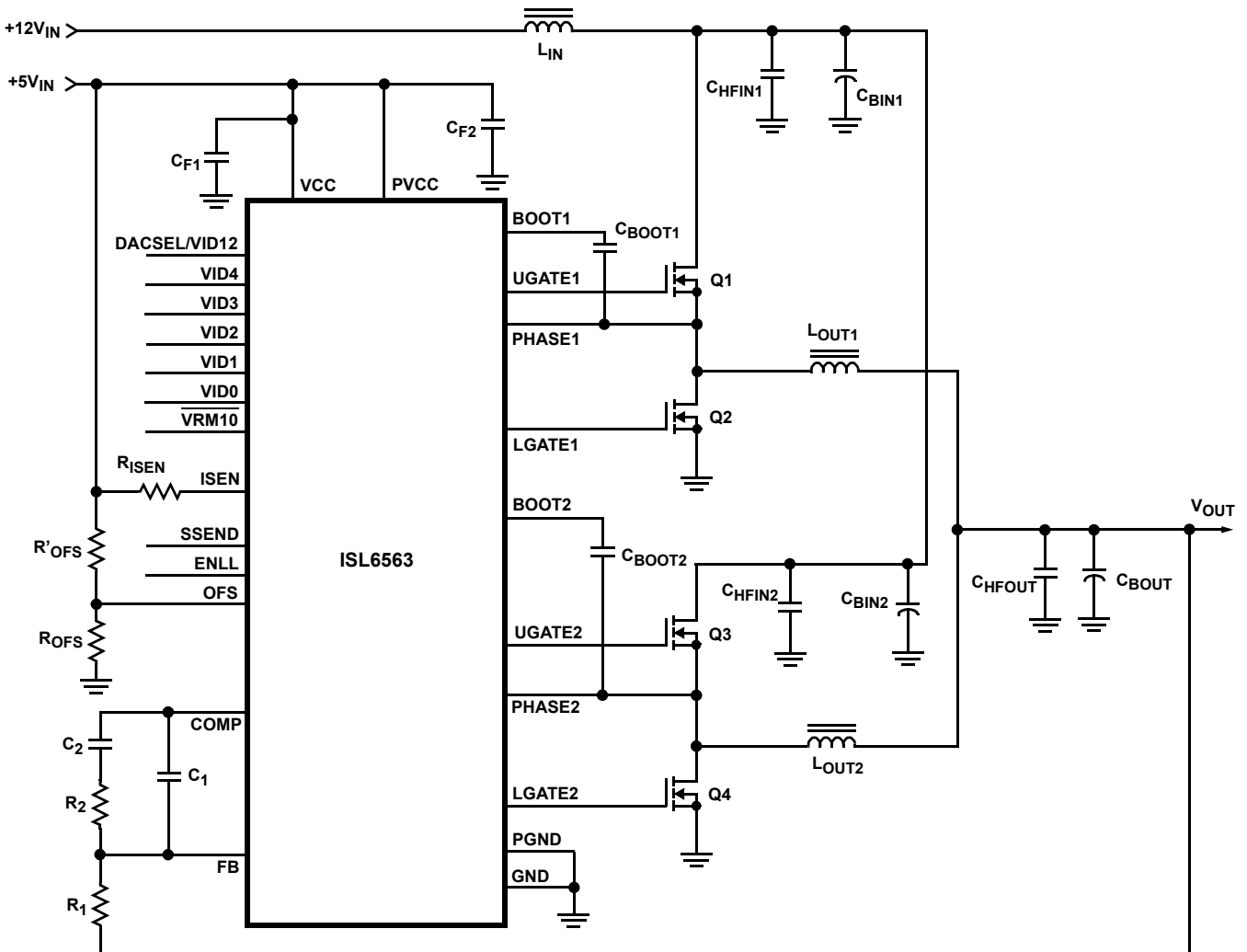

**Absolute Maximum Ratings**

Supply Voltage, VCC, PVCC	-0.3V to +6.25V
Absolute Boot Voltage, V <sub>BOOT</sub>	PGND - 0.3V to PGND + 27V
Phase Voltage, V <sub>PHASE</sub>	V <sub>BOOT</sub> - 7V to V <sub>BOOT</sub> + 0.3V
Upper Gate Voltage, V <sub>UGATE</sub>	V <sub>PHASE</sub> - 0.3V to V <sub>BOOT</sub> + 0.3V
Lower Gate Voltage, V <sub>LGATE</sub>	PGND - 0.3V to VCC + 0.3V
Input, Output, or I/O Voltage	GND - 0.3V to VCC + 0.3V
ESD Classification	HBM Class 1 JEDEC STD

**Thermal Information**

Thermal Resistance	$\theta_{JA}$ (°C/W)	$\theta_{JC}$ (°C/W)
QFN Package (Notes 3, 4)	43	7
Maximum Junction Temperature	+150°C	
Maximum Storage Temperature Range	-65°C to +150°C	
Pb-Free Reflow Profile	see link below <a href="http://www.intersil.com/pbfree/Pb-FreeReflow.asp">http://www.intersil.com/pbfree/Pb-FreeReflow.asp</a>	

**Recommended Operating Conditions**

Supply Voltage	+5V ±5%
Ambient Temperature	0°C to +70°C

**CAUTION:** Do not operate at or near the maximum ratings listed for extended periods of time. Exposure to such conditions may adversely impact product reliability and result in failures not covered by warranty.

**NOTES:**

- $\theta_{JA}$  is measured in free air with the component mounted on a high effective thermal conductivity test board with "direct attach" features. See Tech Brief TB379.
- For  $\theta_{JC}$ , the "case temp" location is the center of the exposed metal pad on the package underside.

**Electrical Specifications** Test Conditions: V<sub>CC</sub> = 5V, T<sub>J</sub> = 0°C to +85°C, Unless Otherwise Specified.

PARAMETER	TEST CONDITIONS	MIN (Note 7)	TYP	MAX (Note 7)	UNITS
<b>BIAS SUPPLY AND INTERNAL OSCILLATOR</b>					
Input Bias Supply Current	I <sub>VCC</sub> ; ENLL = high	-	4	6	mA
VCC POR (Power-On Reset) Threshold	VCC Rising	4.2	4.4	4.6	V
	VCC Falling	3.7	3.9	4.1	V
PVCC POR (Power-On Reset) Threshold	PVCC Rising	-	4.2	-	V
	PVCC Falling	-	3.3	-	V
Switching Frequency (per Channel) (Note 5)	T <sub>J</sub> = +25°C to +85°C	189	222	255	kHz
	T <sub>J</sub> = -40°C	166	205	241	kHz
Oscillator Ramp Amplitude (Note 6)	V <sub>PP</sub>	-	1.33	-	V
Maximum Duty Cycle (Note 6)		-	66	-	%
<b>CONTROL THRESHOLDS</b>					
ENLL Rising Threshold		-	0.61	-	V
ENLL Hysteresis (Note 6)		-	60	-	mV
COMP Shutdown Threshold		0.23	0.36	0.49	V
COMP Shutdown Maximum Pull-Down Impedance		-	-	15	Ω
<b>REFERENCE AND DAC</b>					
System Accuracy		-1	-	1	%
	T <sub>J</sub> = -40°C to +85°C	-1.5	-	1.5	%
DAC Input Low Voltage		-	-	0.4	V
DAC Input High Voltage		0.8	-	-	V
DAC Input Pull-Up Current	VIDX = 0V	-	45	-	μA
<b>ERROR AMPLIFIER</b>					
DC Gain (Note 5)	R <sub>L</sub> = 10k to ground	-	96	-	dB
Gain-Bandwidth Product (Note 6)	C <sub>L</sub> = 100pF, R <sub>L</sub> = 10k to ground	-	20	-	MHz
Slew Rate (Note 6)	C <sub>L</sub> = 100pF, Load = ±400μA	-	8	-	V/μs
Maximum Output Voltage	Load = 1mA	3.90	4.20	-	V
Minimum Output Voltage	Load = -1mA	-	0.80	0.90	V

**Electrical Specifications** Test Conditions:  $V_{CC} = 5V$ ,  $T_J = 0^{\circ}C$  to  $+85^{\circ}C$ , Unless Otherwise Specified. (Continued)

PARAMETER	TEST CONDITIONS	MIN (Note 7)	TYP	MAX (Note 7)	UNITS
<b>OVERCURRENT PROTECTION</b>					
Overcurrent Trip Level		-	95	-	$\mu A$
<b>PROTECTION</b>					
Overvoltage Threshold while IC Disabled	VRM9.0 configuration	1.90	1.95	2.00	V
	Hammer and VRM10.0 configurations	1.60	1.65	1.70	V
Overvoltage Threshold	FB Rising	-	VID +200mV	-	V
Overvoltage Hysteresis		-	100	-	mV
<b>SWITCHING TIME</b>					
UGATE Rise Time (Note 6)	$t_{RUGATE}$ ; $V_{CC} = 5V$ , 3nF Load	-	8	-	ns
LGATE Rise Time (Note 6)	$t_{RLGATE}$ ; $V_{CC} = 5V$ , 3nF Load	-	8	-	ns
UGATE Fall Time (Note 6)	$t_{FUGATE}$ ; $V_{CC} = 5V$ , 3nF Load	-	8	-	ns
LGATE Fall Time (Note 6)	$t_{FLGATE}$ ; $V_{CC} = 5V$ , 3nF Load	-	4	-	ns
UGATE Turn-On Non-overlap (Note 6)	$t_{PDHUGATE}$ ; $V_{CC} = 5V$ , 3nF Load	-	8	-	ns
LGATE Turn-On Non-overlap (Note 6)	$t_{PDHLGATE}$ ; $V_{CC} = 5V$ , 3nF Load	-	8	-	ns
<b>OUTPUT</b>					
Upper Drive Source Resistance	100mA Source Current	-	0.5	1.3	$\Omega$
Upper Drive Sink Resistance	100mA Sink Current	-	0.4	1.0	$\Omega$
Lower Drive Source Resistance	100mA Source Current	-	0.5	1.3	$\Omega$
Lower Drive Sink Resistance	100mA Sink Current	-	0.3	1.0	$\Omega$

NOTES:

- Parameter magnitude at  $T_J = -40^{\circ}C$  determined through characterization.
- Limits should be considered typical and are not production tested.
- Parameters with MIN and/or MAX limits are 100% tested at  $+25^{\circ}C$ , unless otherwise specified. Temperature limits established by characterization and are not production tested.

**Timing Diagram**

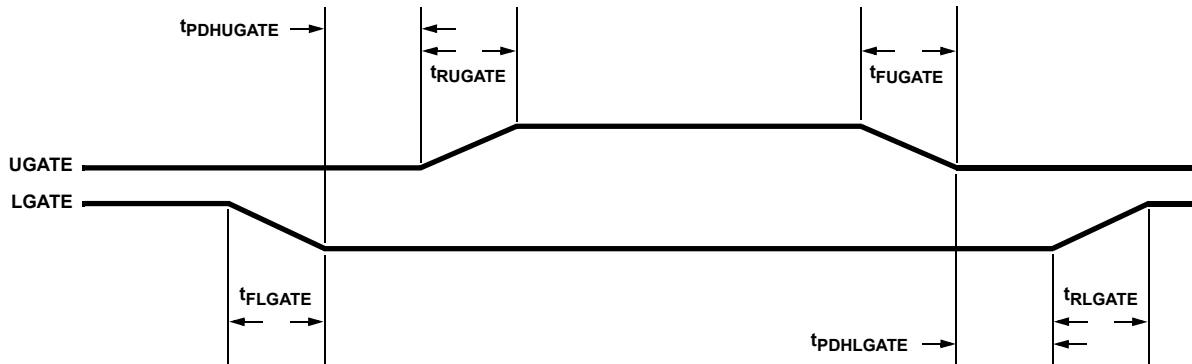

## Functional Pin Description

### VCC (Pin 8)

Bias supply for the IC's small-signal circuitry. Connect this pin to a 5V supply and locally decouple using a quality 0.1 $\mu$ F ceramic capacitor.

### PVCC (Pin 16)

Power supply pin for the MOSFET drives. Connect this pin to a 5V supply and locally decouple using a quality 1 $\mu$ F ceramic capacitor.

### GND and PGND (Pins 25 and 14)

Connect these pins to the circuit ground using the shortest possible paths. All internal small-signal circuitry is referenced to the GND pin. LGATE drive is referenced to the PGND pin.

### VID0-4 (Pins 2, 1, 24-22)

Voltage identification inputs from microprocessor. These pins respond to TTL logic thresholds. The ISL6563 decodes the VID inputs to establish the output voltage; see VID Tables for correspondence between DAC codes and output voltage settings. These pins are internally pulled high, to approximately 1.2V, by 40 $\mu$ A (typically) internal current sources; the internal pull-up current decrease to 0 as the VID voltage approaches the internal pull-up voltage. All VID pins are compatible with external pull-up voltages not exceeding the IC's bias voltage.

### DACSEL/VID5 (Pin 3)

If  $\overline{\text{VRM10}}$  pin is grounded, DACSEL/VID5 represents the 6th voltage identification input from the VRM10-compliant microprocessor, otherwise known as VID5. If  $\overline{\text{VRM10}}$  pin is open or pulled high, DACSEL/VID5 selects the compliance standard for the internal DAC: pulled to ground it encodes the DAC with AMD Hammer VID codes, while left open or pulled high, it encodes the DAC with Intel VRM9.0 codes.

### $\overline{\text{VRM10}}$ (Pin 4)

This pin selects VRM10.0 DAC compliance when grounded. Left open, it allows selection of either VRM9.0 or Hammer DAC compliance via DACSEL pin.

### ENLL (Pin 21)

This pin is a precision-threshold (approximately 0.6V) enable pin. Held low, this pin disables controller operation. Pulled high, the pin enables the controller for operation.

### FB and COMP (Pins 6, 5)

The internal error amplifier's inverting input and output respectively. These pins are connected to the external network used to compensate the regulator's feedback loop.

An internal current source injects the average current sampled through  $R_{\text{ISEN}}$  into the FB pin. Pulling COMP to ground through an impedance lower than 15 $\Omega$  disables the controller (same effect as ENLL pulled low).

### ISEN (Pin 7)

This pin is used to close the current-feedback loop and set the overcurrent protection threshold. A resistor connected between this pin and VCC has a voltage drop forced across it equal to that sampled across the lower MOSFET's  $r_{\text{DS(ON)}}$  during approximately the middle of its conduction interval. The resulting current through this resistor is used for channel current balancing, overcurrent protection and is sourced to the FB pin for load-line regulation. The voltage across the  $R_{\text{ISEN}}$  resistor is time multiplexed between the two channels.

Use Equation 1 to select the proper  $R_{\text{ISEN}}$  resistor:

$$R_{\text{ISEN}} = \frac{r_{\text{DS(ON)}} \times I_{\text{OUT}}}{50\mu\text{A}} \quad (\text{EQ. 1})$$

where:

$r_{\text{DS(ON)}}$  = lower MOSFET drain-source ON-resistance ( $\Omega$ )

$I_{\text{OUT}}$  = channel maximum output current (A)

Read 'Current Feedback' paragraph for more information.

### UGATE1, 2 (Pins 19, 12)

Connect these pins to the upper MOSFETs' gates. These pins are used to control the upper MOSFETs and are monitored for shoot-through prevention purposes. Maximum individual channel duty cycle is limited to 66%.

### BOOT1, 2 (Pins 20, 11)

These pins provide the bias voltage for the upper MOSFETs' drives. Connect these pins to appropriately-chosen external bootstrap capacitors. Internal bootstrap diodes connected to the PVCC pins provide the necessary bootstrap charge.

### PHASE1, 2 (Pins 18, 13)

Connect these pins to the sources of the upper MOSFETs. These pins are the return path for the upper MOSFETs' drives.

### LGATE1, 2 (Pins 17, 15)

These pins are used to control the lower MOSFETs and are monitored for shoot-through prevention purposes. Connect these pins to the lower MOSFETs' gates.

### OFS (Pin 9)

This pin is used to create an adjustable output voltage offset. For no offset, leave this pin open. For negative offset, connect an  $R'_{\text{OFS}}$  resistor from this pin to VCC and size it according to Equation 2:

$$R'_{\text{OFS}} = R_1 \times \frac{1500}{V_{\text{OFFSET}}} \quad (\text{EQ. 2})$$

where:

$V_{\text{OFFSET}}$  = desired output voltage offset magnitude (mV)

For positive output voltage offset, connect an  $R_{\text{OFS}}$  resistor from this pin to GND, sizing it according to Equation 3:

$$R_{\text{OFS}} = R_1 \times \frac{500}{V_{\text{OFFSET}}} \quad (\text{EQ. 3})$$

For more information, refer to the 'Output Voltage Offset Programming' paragraph.

**SSEND (Pin 10)**

This pin is an end of Soft-Start (SS) indicator; open drain output device stays ON during soft-start, and goes open when soft-start ends.

**Operation**

Figure 1 shows a simplified diagram of the voltage regulation and current control loops. Both voltage and current feedback are used to precisely regulate the output voltage and tightly control the output currents,  $I_{L1}$  and  $I_{L2}$ , of the two power channels.

**Voltage Loop**

Feedback from the output voltage is applied via resistor R1 to the inverting input of the Error Amplifier. This signal can drive the Error Amplifier output either high or low, depending upon the output voltage. Low output voltage makes the amplifier output move towards a higher output voltage level. Amplifier output voltage is applied to the positive inputs of the PWM Circuit comparators via the correction summing networks. Out-of-phase sawtooth signals are applied to the two PWM comparators inverting inputs. Increasing Error Amplifier voltage results in increased Comparator output duty cycle. This increased duty cycle signal is passed

through the output drivers with no phase reversal to drive the external upper MOSFETs. Increased duty cycle or ON time for the upper MOSFET transistors results in increased output voltage to compensate for the low output voltage sensed.

**Current Loop**

The current control loop works in a similar fashion to the voltage control loop, but with current control information applied individually to each channel's Comparator. The information used for this control is the voltage that is developed across the  $r_{DS(ON)}$  of each lower MOSFET, while they are conducting. A single resistor converts and scales the voltage across the MOSFETs to a current that is applied to the Current Sensing circuit within the ISL6563. Output from these sensing circuits is applied to the current averaging circuit. Each PWM channel receives the difference current signal from the summing circuit that compares the average sensed current to the individual channel current. When a power channel's current is greater than the average current, the signal applied via the summing Correction circuit to the Comparator, reduces the output pulse width of the Comparator to compensate for the detected "above average" current in that channel.

**Droop Implementation**

In addition to controlling each channel's output current, the average channel current is used to implement an output

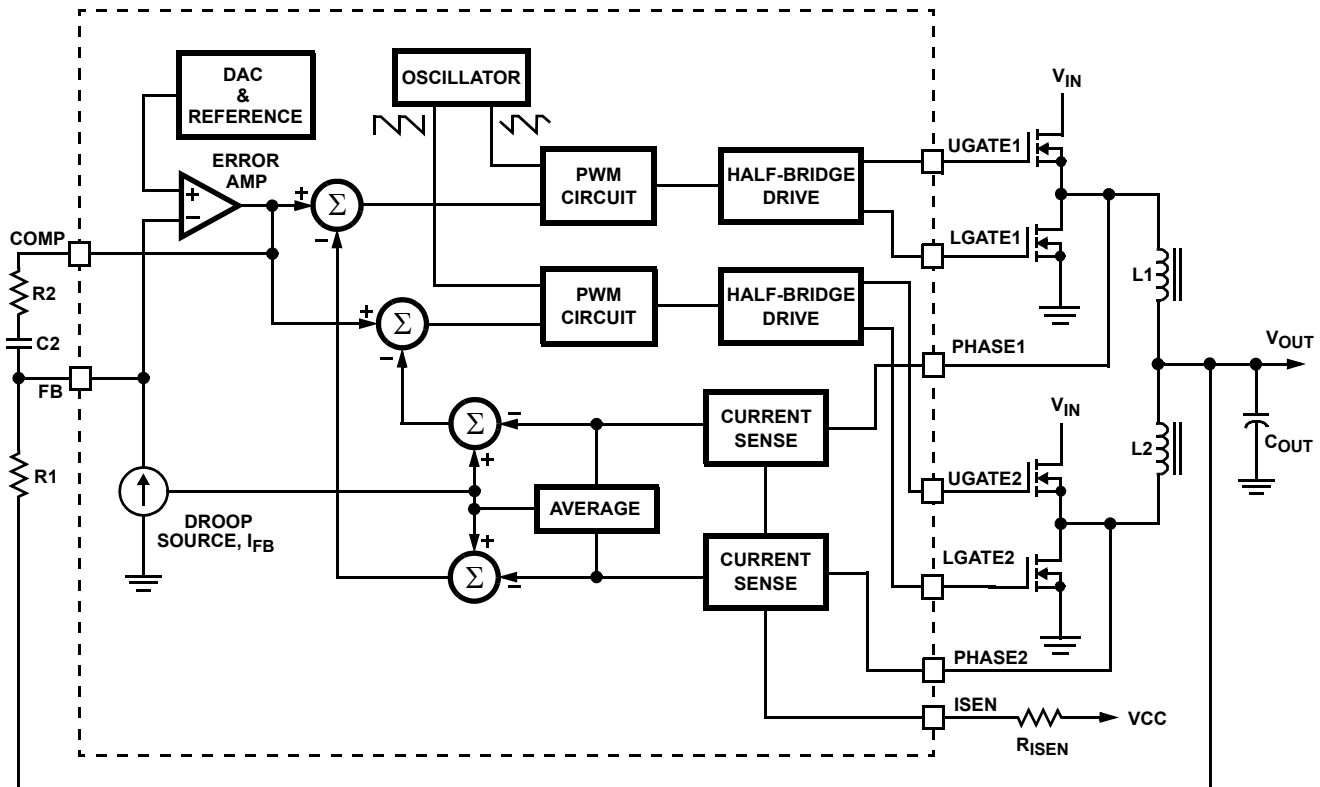

FIGURE 1. SIMPLIFIED BLOCK DIAGRAM OF THE ISL6563 VOLTAGE AND CURRENT CONTROL LOOPS

voltage droop characteristic. Internal average channel current is fed into the FB pin; the voltage thus developed across  $R_1$  is equal to the droop voltage.

Assuming identical power switch selection on the two channels, Equation 4 determines the current fed out the FB pin for output voltage droop generation:

$$I_{FB} = \frac{r_{DS(ON)} \cdot I_{PHASE}}{R_{ISEN}} \quad (\text{EQ. 4})$$

where,  $r_{DS(ON)}$  - lower MOSFET/s' ON resistance (@5V)

$I_{PHASE}$  - average phase current

### Multiphase Power Conversion

Multiphase power conversion provides a cost-effective power solution when load currents are no longer easily supported by single-phase converters. Although its greater complexity presents additional technical challenges, the multiphase approach offers cost-saving advantages with improved response time, superior ripple cancellation, and thermal distribution.

### INTERLEAVING

The switching of each channel in an ISL6563-based converter is timed to be symmetrically out of phase with the other channel. As a result, the two-phase converter has a combined ripple frequency twice the frequency of one of its phases. In addition, the peak-to-peak amplitude of the combined inductor currents is proportionately reduced. Increased ripple frequency and lower ripple amplitude generally translate to lower per-channel inductance and lower total output capacitance for a given set of performance specifications.

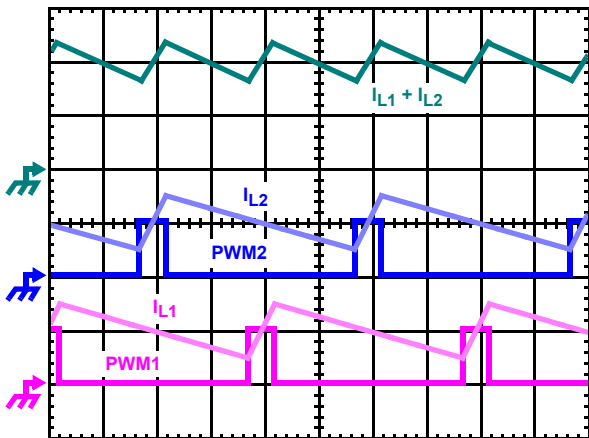

FIGURE 2. PWM AND INDUCTOR-CURRENT WAVEFORMS FOR 2-PHASE CONVERTER

Figure 2 illustrates the additive effect on output ripple frequency. The two channel currents ( $I_{L1}$  and  $I_{L2}$ ), combine to form the AC ripple current and the DC load current. The ripple component has two times the ripple frequency of each individual channel current.

To understand the reduction of ripple current amplitude in the multiphase circuit, examine Equation 5, which represents an individual channel's peak-to-peak inductor current.

$$I_{L,PP} = \frac{(V_{IN} - V_{OUT}) \cdot V_{OUT}}{L \cdot f_S \cdot V_{IN}} \quad (\text{EQ. 5})$$

$V_{IN}$  and  $V_{OUT}$  are the input and output voltages, respectively,  $L$  is the single-channel inductor value, and  $f_S$  is the switching frequency.

The output capacitors conduct the ripple component of the inductor current. In the case of multiphase converters, the capacitor current is the sum of the ripple currents from each of the individual channels. Peak-to-peak ripple current,  $I_{PP}$ , decreases by an amount proportional to the number of channels. Output-voltage ripple is a function of capacitance, capacitor equivalent series resistance (ESR), and inductor ripple current. Reducing the inductor ripple current allows the designer to use fewer or less costly output capacitors (should output ripple be an important design parameter).

$$I_{PP} = \frac{(V_{IN} - N \cdot V_{OUT}) \cdot V_{OUT}}{L \cdot f_S \cdot V_{IN}} \quad (\text{EQ. 6})$$

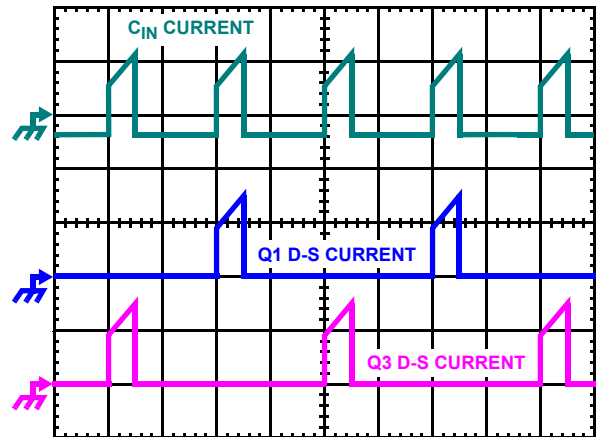

FIGURE 3. INPUT CAPACITOR CURRENT AND INDIVIDUAL CHANNEL CURRENTS IN A 2-PHASE CONVERTER

Another benefit of interleaving is the reduction of input ripple current. Input capacitance is determined in a large part by the maximum input ripple current. Multiphase topologies can improve overall system cost and size by lowering input ripple current and allowing the designer to reduce the cost of input capacitance. The example in Figure 3 illustrates input currents from a two-phase converter combining to reduce the total input ripple current.

Figure 11, part of "Input Capacitor Selection" on page 18, can be used to determine the input-capacitor RMS current based on load current and duty cycle. The figure is provided as an aid in determining the optimal input capacitor solution.

## PWM OPERATION

One switching cycle for the ISL6563 is defined as the time between consecutive PWM pulse terminations (turn-off of the upper MOSFET on a channel). Each cycle begins when a switching clock signal commands the upper MOSFET to go off. The other channel's upper MOSFET conduction is terminated 1/2 of a cycle later.

Once a channel's upper MOSFET is turned off, the lower MOSFET remains on for a minimum of 1/3 cycle. This forced off time is required to assure an accurate current sample. Following the 1/3-cycle forced off time, the controller enables the upper MOSFET output. Once enabled, the upper MOSFET output transitions high when the sawtooth signal crosses the adjusted error-amplifier output signal, as illustrated in the ISL6563's block diagram. Just prior to the upper drive turning the MOSFET on, the lower MOSFET drive turns the freewheeling element off. The upper MOSFET is kept on until the clock signals the beginning of the next switching cycle and the PWM pulse is terminated.

## CURRENT SENSING

ISL6563 senses current by sampling the voltage across the lower MOSFET during its conduction interval. MOSFET  $r_{DS(ON)}$  sensing is a no-added-cost method to sense current for load line regulation, channel current balance, module current sharing, and overcurrent protection.

The PHASE pins are used as inputs for each channel. Internal circuitry samples the lower MOSFETs'  $r_{DS(ON)}$  voltage, once each cycle, during their conduction periods and time multiplexes the sampled voltages across the ISEN resistor. The current that is thus developed through the ISEN resistor is duplicated and fed back through the FB pin to create droop, as well as used for channel current balancing.

## CHANNEL-CURRENT BALANCE

Another benefit of multiphase operation is the thermal advantage gained by distributing the dissipated heat over multiple devices and greater area. By doing this, the designer avoids the complexity of driving multiple parallel MOSFETs and the expense of using expensive heat sinks and exotic magnetic materials.

In order to fully realize the thermal advantage, it is important that each channel in a multiphase converter be controlled to deliver about the same current at any load level. Intersil multiphase controllers ensure current balance by comparing each channel's current to the average current delivered by all channels and making appropriate adjustments to each channel's pulse width based on the error. The error signal modifies the pulse width to correct any unbalance and force the error toward zero.

## OVERCURRENT PROTECTION

The individual channel currents, as sensed via the PHASE pins and scaled via the ISEN resistor, are continuously monitored and compared with an internal 95 $\mu$ A reference

current. If both channels' currents exceed, at any time, the reference current, the overcurrent comparator triggers an overcurrent event. Similarly, an OC event is also triggered if either channel's current exceeds the 95 $\mu$ A reference for 7 consecutive switching cycles.

As a result of an OC event, output drives on both channels turn off both upper and lower MOSFETs. The system then waits in this state for a period of 4096 switching clock cycles.

The wait period is followed by a soft-start attempt. If the soft-start attempt is successful, operation continues as normal. Should the soft-start attempt fail, the ISL6563 repeats the 2048-cycle wait period and follows with another soft-start attempt. This hiccup mode of operation continues indefinitely (as depicted in Figure 4) for as long as the controller is enabled or until the overcurrent condition is removed.

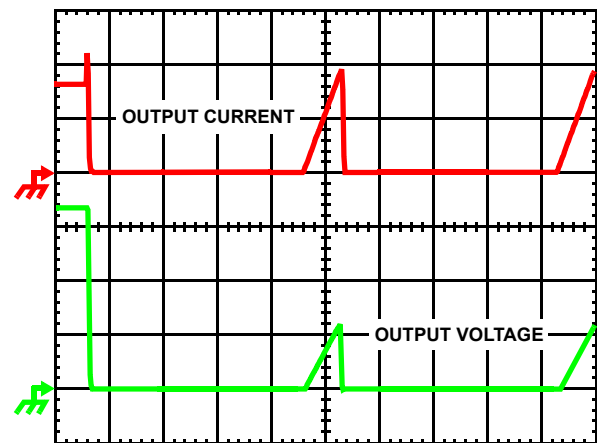

FIGURE 4. OVERCURRENT BEHAVIOR IN HICCUP MODE

## OUTPUT VOLTAGE SETTING

The ISL6563 uses a digital to analog converter (DAC) to generate a reference voltage based on the logic signals at the VID pins. The DAC decodes the 5 or 6-bit logic signals into one of the discrete voltages shown in Tables 1 through 3. Each VID pin is pulled up to an internal 1.2V voltage by weak current sources (about 45 $\mu$ A current, decreasing to 0 as the voltage at the VID pins varies from 0 to the internal 1.2V pull-up voltage). External pull-up resistors or active-high output stages can augment the pull-up current sources, up to a voltage of 5V.

The ISL6563 accommodates three different DAC ranges: Intel VRM9.0, AMD Hammer, or Intel VRM10.0 - see "Functional Pin Description" on page 6 for proper connections for DAC range compatibility.

TABLE 1. AMD HAMMER VOLTAGE IDENTIFICATION CODES

VID4	VID3	VID2	VID1	VID0	VDAC
1	1	1	1	1	Off
1	1	1	1	0	0.800
1	1	1	0	1	0.825
1	1	1	0	0	0.850

TABLE 1. AMD HAMMER VOLTAGE IDENTIFICATION CODES (Continued)

VID4	VID3	VID2	VID1	VID0	VDAC
1	1	0	1	1	0.875
1	1	0	1	0	0.900
1	1	0	0	1	0.925
1	1	0	0	0	0.950
1	0	1	1	1	0.975
1	0	1	1	0	1.000
1	0	1	0	1	1.025
1	0	1	0	0	1.050
1	0	0	1	1	1.075
1	0	0	1	0	1.100
1	0	0	0	1	1.125
1	0	0	0	0	1.150
0	1	1	1	1	1.175
0	1	1	1	0	1.200
0	1	1	0	1	1.225
0	1	1	0	0	1.250
0	1	0	1	1	1.275
0	1	0	1	0	1.300
0	1	0	0	1	1.325
0	1	0	0	0	1.350
0	0	1	1	1	1.375
0	0	1	1	0	1.400
0	0	1	0	1	1.425
0	0	1	0	0	1.450
0	0	0	1	1	1.475
0	0	0	1	0	1.500
0	0	0	0	1	1.525
0	0	0	0	0	1.550

TABLE 2. VRM9 VOLTAGE IDENTIFICATION CODES

VID4	VID3	VID2	VID1	VID0	VDAC
1	1	1	1	1	Off
1	1	1	1	0	1.100
1	1	1	0	1	1.125
1	1	1	0	0	1.150
1	1	0	1	1	1.175
1	1	0	1	0	1.200
1	1	0	0	1	1.225
1	1	0	0	0	1.250
1	0	1	1	1	1.275
1	0	1	1	0	1.300
1	0	1	0	1	1.325
1	0	1	0	0	1.350
1	0	0	1	1	1.375
1	0	0	1	0	1.400
1	0	0	0	1	1.425
1	0	0	0	0	1.450
0	1	1	1	1	1.475
0	1	1	1	0	1.500
0	1	1	0	1	1.525
0	1	1	0	0	1.550
0	1	0	1	1	1.575
0	1	0	1	0	1.600
0	1	0	0	1	1.625
0	1	0	0	0	1.650
0	0	1	1	1	1.675
0	0	1	1	0	1.700
0	0	1	0	1	1.725
0	0	1	0	0	1.750
0	0	0	1	1	1.775
0	0	0	1	0	1.800
0	0	0	0	1	1.825
0	0	0	0	0	1.850

TABLE 3. VRM10 VOLTAGE IDENTIFICATION CODES

VID4	VID3	VID2	VID1	VID0	VID5	VDAC
1	1	1	1	1	1	Off
1	1	1	1	1	0	Off
0	1	0	1	0	0	0.8375
0	1	0	0	1	1	0.8500
0	1	0	0	1	0	0.8625
0	1	0	0	0	1	0.8750
0	1	0	0	0	0	0.8875
0	0	1	1	1	1	0.9000
0	0	1	1	1	0	0.9125
0	0	1	1	0	1	0.9250
0	0	1	1	0	0	0.9375
0	0	1	0	1	1	0.9500
0	0	1	0	1	0	0.9625
0	0	1	0	0	1	0.9750
0	0	1	0	0	0	0.9875
0	0	0	1	1	1	1.0000
0	0	0	1	1	0	1.0125
0	0	0	1	0	1	1.0250
0	0	0	1	0	0	1.0375
0	0	0	0	1	1	1.0500
0	0	0	0	1	0	1.0625
0	0	0	0	0	1	1.0750
0	0	0	0	0	0	1.0875
1	1	1	1	0	1	1.1000
1	1	1	1	0	0	1.1125
1	1	1	0	1	1	1.1250
1	1	1	0	1	0	1.1375
1	1	1	0	0	1	1.1500
1	1	1	0	0	0	1.1625
1	1	0	1	1	1	1.1750
1	1	0	1	1	0	1.1875
1	1	0	1	0	1	1.2000
1	1	0	1	0	0	1.2125
1	1	0	0	1	1	1.2250
1	1	0	0	1	0	1.2375
1	1	0	0	0	1	1.2500
1	1	0	0	0	0	1.2625
1	0	1	1	1	1	1.2750
1	0	1	1	1	0	1.2875
1	0	1	1	0	1	1.3000
1	0	1	1	0	0	1.3125
1	0	1	0	1	1	1.3250
1	0	1	0	1	0	1.3375
1	0	1	0	0	1	1.3500
1	0	1	0	0	0	1.3625

TABLE 3. VRM10 VOLTAGE IDENTIFICATION CODES (Continued)

VID4	VID3	VID2	VID1	VID0	VID5	VDAC
1	0	0	1	1	1	1.3750
1	0	0	1	1	0	1.3875
1	0	0	1	0	1	1.4000
1	0	0	1	0	0	1.4125
1	0	0	0	1	1	1.4250
1	0	0	0	1	0	1.4375
1	0	0	0	0	1	1.4500
1	0	0	0	0	0	1.4625
0	1	1	1	1	1	1.4750
0	1	1	1	1	0	1.4875
0	1	1	1	0	1	1.5000
0	1	1	1	0	0	1.5125
0	1	1	0	1	1	1.5250
0	1	1	0	1	0	1.5375
0	1	1	0	0	1	1.5500
0	1	1	0	0	0	1.5625
0	1	0	1	1	1	1.5750
0	1	0	1	1	0	1.5875
0	1	0	1	0	1	1.6000

**DYNAMIC VID (VID-ON-THE-FLY)**

The ISL6563 is capable of executing on-the-fly output voltage changes. The way the ISL6563 reacts to a change in the VID code is dependent on the VID configuration. In VRM9 or AMD Hammer settings, the ISL6563 checks for a change in the VID code four times each switching cycle. The VID code is the bit pattern present at pins VID4-VID0. If a new code is established and it stays the same for 12 switching cycles, the ISL6563 begins changing the reference by making one step change every four switching cycles until it reaches the new VID code. Figure 5 depicts such a transition, from 1.5V to 1.7V

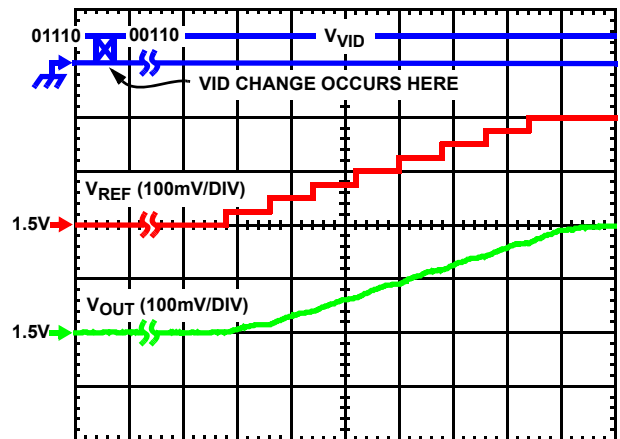

FIGURE 5. TYPICAL DYNAMIC-VID OPERATION, VRM9 DAC SETTING

In VRM10 setting, the ISL6563 checks for a change in the VID code six times each switching cycle. If a new code is established and it stays the same for 3 consecutive readings, the ISL6563 recognizes the change and increments the reference. Specific to VRM10, the processor controls the VID transitions and is responsible for incrementing or decrementing one VID step at a time. In VRM10 setting, the ISL6563 will immediately change the reference to the new requested value as soon as the request is validated; in cases where the reference step is too large, the sudden change can trigger overcurrent or overvoltage events.

In non-VRM10 settings, due to the way the ISL6563 recognizes VID code changes, up to one full switching period may pass before a VID change registers. Thus, the total time required for a VID change,  $t_{DVID}$ , is dependent on the switching frequency ( $f_S$ ), the size of the change ( $\Delta V_{ID}$ ), and the time required to register the VID change. The approximate time required for an ISL6563-based converter in VRM9 configuration running at typical  $f_S$  (222kHz) to perform a 1.5V-to-1.7V reference voltage change is about 196 $\mu$ s, as calculated using Equation 7 (this example is also illustrated in Figure 5).

$$t_{DVID} \cong \frac{1}{f_S} \left( \frac{4\Delta V_{VID}}{0.025} + 13 \right) \quad (\text{EQ. 7})$$

## OVERVOLTAGE PROTECTION

The ISL6563 benefits from a multi-tiered approach to overvoltage protection.

A pre-POR mechanism is at work while the chip does not have sufficient bias voltage to initiate an active response to an OV situation. Thus, while VCC is below its POR level, the lower drives are tristated and internal 5k $\Omega$  (typically) resistors are connected from PHASE to their respective LGATE pins. As a result, output voltage, duplicated at the PHASE nodes via the output inductors, is effectively clamped at the lower MOSFETs' threshold level. This approach ensures no catastrophic output voltage can be developed at the output of an ISL6563-based regulator (for most typical applications).

The pre-POR mechanism is removed once the bias is above the POR level, and a fixed-threshold OVP goes into effect. Based on the specific chip configuration, the OVP goes into effect once the voltage sensed at the FB pin exceeds about 1.65V (Hammer/VR10) or 1.95V (VR9 configuration). Should the output voltage exceed these thresholds, the lower MOSFETs are turned on.

During soft-start, the OVP threshold changes to the higher of the fixed threshold (1.65V/1.95V) or the DAC setting plus 200mV. At the end of the soft-start, the OVP threshold changes to the DAC setting plus 200mV.

In any of the described post-POR functionality, OVP results in the turn-on of the lower MOSFETs. Once turned on, the lower MOSFETs are only turned off when the output voltage

drops below the OV comparator's hysteretic threshold. The OVP process repeats if the voltage rises back above the designated threshold. The occurrence of an OVP event does not latch the controller; should the phenomenon be transitory, the controller resumes normal operation following such an event.

## LOAD-LINE REGULATION

In applications with high transient current slew rates, the lowest-cost solution for maintaining regulation often requires some kind of controlled output impedance. The FB pin of the ISL6563 carries a current proportional to the average output current of the converter. The current is equivalent to  $I_{FB}$  in Figure 1. Forcing  $I_{FB}$  into the summing node of the error amplifier produces a voltage drop across the feedback resistor,  $R_{FB}$ , proportional to the output current. Assuming the current is shared equally by both phases, the steady-state value of  $V_{DROOP}$  is simply:

$$V_{DROOP} = I_{FB} \cdot R_{FB} \quad (\text{EQ. 8})$$

$$V_{DROOP} = \frac{I_{OUT} \cdot r_{DS(ON)LMOS}}{2 \cdot R_{ISEN}} \cdot R_{FB}$$

## ON/OFF CONTROL

The internal power-on reset circuit (POR) prevents the ISL6563 from starting before the bias voltage at VCC and PVCC reach the rising POR thresholds, as defined in "Electrical Specifications" table on page 4. The POR levels are sufficiently high to guarantee that all parts of the ISL6563 can perform their functions properly once bias is applied to the part. While bias is below the rising POR thresholds, the controlled MOSFETs are kept in an off state.

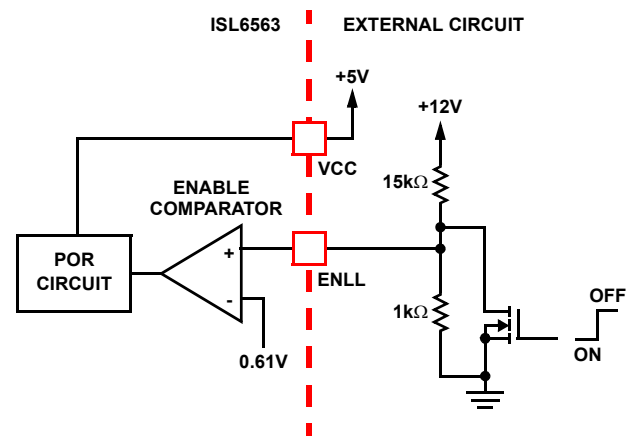

FIGURE 6. START-UP COORDINATION USING THRESHOLD-SENSITIVE ENABLE (ENLL) PIN

A secondary disablement feature is available via the threshold-sensitive enable input (ENLL). This optional feature prevents the ISL6563 from operating until a certain other voltage rail is available and above some selectable threshold. For example, when down-converting off a 12V input, it may be desirable the ISL6563-based converter does not start up until the power input is sufficiently high. The

schematic in Figure 6 demonstrates coordination of the ISL6563 with such a rail; the resistor components are chosen to enable the ISL6563 as the 12V input exceeds approximately 9.75V. Additionally, an open-drain or open-collector device can be used to wire-AND a second (or multiple) control signal, as shown in Figure 6. To defeat the threshold-sensitive enable, connect ENLL to VCC directly or via a pull-up resistor.

The '11111' VID code is reserved as a signal to the controller that no load is present. The controller is disabled while receiving this VID code and will subsequently start up upon receiving any other code.

In summary, for the ISL6563 to operate, the following conditions need be met: VCC and PVCC must be greater than their respective POR thresholds, the voltage at ENLL must be greater than 0.61V, and VID has to be different than '11111'. Once all these conditions are met, the controller immediately initiates a soft start sequence.

### SOFT-START

The soft-start function allows the converter to bring up the output voltage in a controlled fashion, resulting in a linear ramp-up. Following a delay of 16 PHASE clock cycles (about 70 $\mu$ s) between enabling the chip and the start of the ramp, the output voltage progresses at a fixed rate of 12.5mV per 16 PHASE clock cycles.

Thus, the soft-start period (not including the 70 $\mu$ s wait) up to a given voltage,  $V_{DAC}$ , can be approximated by Equation 9:

$$T_{SS} = \frac{V_{DAC} \cdot 1280}{f_s} \quad (\text{EQ. 9})$$

where  $V_{DAC}$  is the DAC-set VID voltage, and  $f_s$  is the switching frequency (typically 222kHz).

The ISL6563 also has the ability to start up into a pre-charged output, without causing any unnecessary disturbance. The FB pin is monitored during soft-start, and should it be higher than the equivalent internal ramping reference voltage, the output drives hold both MOSFETs off. Once the internal ramping reference exceeds the FB pin potential, the output drives are enabled, allowing the output to ramp from the pre-charged level to the final level dictated by the DAC setting. Should the output be pre-charged to a level exceeding the DAC setting, the output drives are enabled at the end of the soft-start period, leading to an abrupt correction in the output voltage down to the DAC-set level.

## General Application Design Guide

This design guide is intended to provide a high-level explanation of the steps necessary to create a multiphase power converter. It is assumed that the reader is familiar with many of the basic skills and techniques referenced below. In addition to this guide, Intersil provides complete reference designs that include schematics, bills of materials, and

example board layouts for all common microprocessor applications.

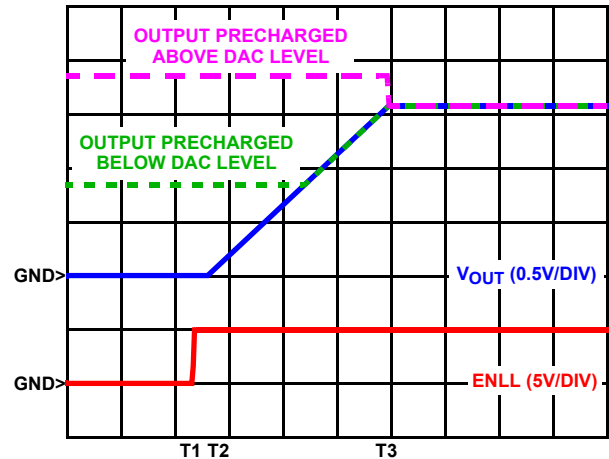

FIGURE 7. SOFT-START WAVEFORMS FOR ISL6563-BASED MULTIPHASE CONVERTER

### MOSFETs

Given the fixed switching frequency of the ISL6563 and the integrated output drives, the selection of MOSFETs revolves closely around the current each MOSFET is required to conduct, the capability of the devices to dissipate heat, as well as the characteristics of available heat sinking. Since the ISL6563 drives the MOSFETs with 5V, the selection of appropriate MOSFETs should be done by comparing and evaluating their characteristics at this specific  $V_{GS}$  bias voltage.

### LOWER MOSFET POWER CALCULATION

Since virtually all of the heat loss in the lower MOSFET is conduction loss (due to current conducted through the channel resistance,  $r_{DS(ON)}$ ), a quick approximation for heat dissipated in the lower MOSFET can be found in Equation 10:

$$P_{LMOS1} = r_{DS(ON)} \left[ \left( \frac{I_{OUT}}{2} \right)^2 (1-D) + \frac{I_{L,PP}^2 (1-D)}{12} \right] \quad (\text{EQ. 10})$$

where:  $I_M$  is the maximum continuous output current,  $I_{L,PP}$  is the peak-to-peak inductor current, and  $D$  is the duty cycle (approximately  $V_{OUT}/V_{IN}$ ).

An additional term can be added to the lower-MOSFET loss equation to account for additional loss accrued during the dead time when inductor current is flowing through the lower-MOSFET body diode. This term is dependent on the diode forward voltage at  $I_M$ ,  $V_{D(ON)}$ ; the switching frequency,  $f_s$ ; and the length of dead times,  $t_{d1}$  and  $t_{d2}$ , at the beginning and the end of the lower-MOSFET conduction interval, respectively.

$$P_{LMOS2} = V_{D(ON)} f_s \left[ \left( \frac{I_{OUT}}{2} + \frac{I_{PP}}{2} \right) t_{d1} + \left( \frac{I_{OUT}}{2} - \frac{I_{PP}}{2} \right) t_{d2} \right] \quad (\text{EQ. 11})$$

The above equation assumes the current through the lower MOSFET is always positive; if so, the total power dissipated in each lower MOSFET is approximated by the summation of  $P_{LMOS1}$  and  $P_{LMOS2}$ .

**UPPER MOSFET POWER CALCULATION**

In addition to  $r_{DS(ON)}$  losses, a large portion of the upper-MOSFET losses are switching losses, due to currents conducted through the device while the input voltage is present as  $V_{DS}$ . Upper MOSFET losses can be divided into separate components, separating the upper-MOSFET switching losses, the lower-MOSFET body diode reverse recovery charge loss, and the upper MOSFET  $r_{DS(ON)}$  conduction loss.

In most typical circuits, when the upper MOSFET turns off, it continues to conduct the inductor current until the voltage at the phase node falls below ground. Once the lower MOSFET begins conducting (via its body diode or enhancement channel), the current in the upper MOSFET falls to zero. In Equation 12, the required time for this commutation is  $t_1$  and the associated power loss is  $P_{UMOS,1}$ .

$$P_{UMOS,1} \approx V_{IN} \left( \frac{I_{OUT}}{2} + \frac{I_{L,PP}}{2} \right) \left( \frac{t_1}{2} \right) f_s \tag{EQ. 12}$$

Similarly, the upper MOSFET begins conducting as soon as it begins turning on. Assuming the inductor current is in the positive domain, the upper MOSFET sees approximately the input voltage applied across its drain and source terminals, while it turns on and starts conducting the inductor current. This transition occurs over a time  $t_2$ , and the approximate the power loss is  $P_{UMOS,2}$ .

$$P_{UMOS,2} \approx V_{IN} \left( \frac{I_{OUT}}{2} - \frac{I_{L,PP}}{2} \right) \left( \frac{t_2}{2} \right) f_s \tag{EQ. 13}$$

A third component involves the lower MOSFET’s reverse-recovery charge,  $Q_{RR}$ . Since the lower MOSFET’s body diode conducts the full inductor current before it has fully switched to the upper MOSFET, the upper MOSFET has to provide the charge required to turn off the lower MOSFET’s body diode. This charge is conducted through the upper MOSFET across  $V_{IN}$ , the power dissipated as a result,  $P_{UMOS,3}$  can be approximated using Equation 14:

$$P_{UMOS,3} = V_{IN} Q_{rr} f_s \tag{EQ. 14}$$

Lastly, the conduction loss part of the upper MOSFET’s power dissipation,  $P_{UMOS,4}$ , can be calculated using Equation 15:

$$P_{UMOS,4} = r_{DS(ON)} \left[ \left( \frac{I_{OUT}}{2} \right)^2 d + \frac{I_{PP}^2}{12} \right] \tag{EQ. 15}$$

In this case, of course,  $r_{DS(ON)}$  is the ON-resistance of the upper MOSFET.

The total power dissipated by the upper MOSFET at full load can be approximated as the summation of these results.

Since the power equations depend on MOSFET parameters, choosing the correct MOSFETs can be an iterative process that involves repetitively solving the loss equations for different MOSFETs and different switching frequencies until converging upon the best solution.

**Current Sensing**

The resistor connected between the ISEN and VCC pins determines the gain in the load-line regulation and the channel-current balance loop. Select the value for this resistor based on the room temperature  $r_{DS(ON)}$  of the lower MOSFETs and the full-load total output current,  $I_{FL}$ .

$$R_{ISEN} = \frac{r_{DS(ON)} \cdot I_{FL}}{50 \times 10^{-6} \cdot 2} \tag{EQ. 16}$$

**Load Line Regulation Resistor**

The load-line regulation resistor is labeled, R1 in Figure 1, depends on the desired full-load droop voltage. At full load, the current determined by  $R_{ISEN}$  is fed into the FB pin and creates the output voltage droop across R1. Thus, the load line regulation resistor can be computed using Equation 17:

$$R_1 = \frac{V_{DROOP} \cdot 2 \cdot R_{ISEN}}{r_{DS(ON)} \cdot I_{FL}} \tag{EQ. 17}$$

**Frequency Compensation**

The load-line regulated converter behaves in a similar manner to a peak-current mode controller because the two poles at the output filter LC resonant frequency split with the introduction of current information into the control loop. The final location of these poles is determined by the system function, the gain of the current signal, and the value of the compensation components,  $R_2$  and  $C_2$ .

The solution to the system equations can be fairly complicated. Fortunately, there is a simple approximation that comes very close to an optimal solution. Treating the system as though it were a voltage mode regulator by compensating the LC poles and the ESR zero of the voltage mode approximation yields a solution that is always stable with very close to ideal transient performance.

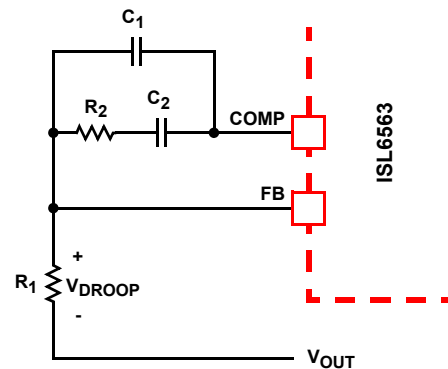

FIGURE 8. COMPENSATION CONFIGURATION FOR ISL6563 CIRCUIT

The feedback resistor,  $R_1$ , has already been chosen as outlined in “Load Line Regulation Resistor” on page 14. Select a target bandwidth for the compensated system,  $f_0$ . The target bandwidth must be large enough to ensure adequate transient performance, but smaller than 1/3 of the per-channel switching frequency (75kHz in this case). The values of the compensation components depend on the relationships of  $f_0$  to the output filter, LC, double pole frequency and the ESR zero frequency of the bulk output capacitor bank. For each of the three cases defined in the following, there is a separate set of equations for the compensation components.

Case 1:

$$\frac{1}{2\pi \cdot \sqrt{LC}} > f_0$$

$$R_2 = R_1 \cdot \frac{2\pi \cdot f_0 \cdot V_{PP} \cdot \sqrt{LC}}{0.66 \cdot V_{IN}} \quad (\text{EQ. 18})$$

$$C_2 = \frac{0.66 \cdot V_{IN}}{2\pi \cdot V_{PP} \cdot R_{FB} \cdot f_0}$$

Case 2:

$$\frac{1}{2\pi \cdot \sqrt{LC}} \leq f_0 \leq \frac{1}{2\pi \cdot C \cdot \text{ESR}}$$

$$R_2 = R_1 \cdot \frac{V_{PP} \cdot (2\pi)^2 \cdot f_0^2 \cdot LC}{0.66 \cdot V_{IN}} \quad (\text{EQ. 19})$$

$$C_2 = \frac{0.66 \cdot V_{IN}}{(2\pi)^2 \cdot f_0^2 \cdot V_{PP} \cdot R_1 \cdot \sqrt{LC}}$$

Case 3:

$$f_0 > \frac{1}{2\pi \cdot C \cdot \text{ESR}}$$

$$R_2 = R_1 \cdot \frac{2\pi \cdot f_0 \cdot V_{PP} \cdot L}{0.66 \cdot V_{IN} \cdot \text{ESR}} \quad (\text{EQ. 20})$$

$$C_2 = \frac{0.66 \cdot V_{IN} \cdot \text{ESR} \cdot \sqrt{C}}{2\pi \cdot V_{PP} \cdot R_1 \cdot f_0 \cdot \sqrt{L}}$$

In the previous equations, L is the per-channel filter inductance divided by the number of active channels, C is the total bulk output capacitance, ESR is the equivalent series resistance of the bulk output filter capacitance, and  $V_{PP}$  is the peak-to-peak sawtooth signal amplitude (see “Electrical Specifications” table on page 4).

Once selected, the compensation values assure a stable converter with reasonable transient performance.  $C_1$  is needed to cut down the high frequency error amplifier gain and reduce the noise the PWM comparator sees. Keep a position available for  $C_1$ , and install a 10pF to 47pF in case jitter is noted.

### Output Filter Design

The output inductors and the output capacitor bank together to form a low-pass filter responsible for smoothing the square wave voltage at the phase nodes. Additionally, the output capacitors must also provide the energy required by a

fast transient load during the short interval of time required by the controller and power train to respond. Because it has a low bandwidth compared to the switching frequency, the output filter limits the system transient response leaving the output capacitor bank to supply the load current or sink the inductor currents, all while the current in the output inductors increases or decreases to meet the load demand.

In high-speed converters, the output capacitor bank is amongst the costlier (and often the physically largest) parts of the circuit. Output filter design begins with consideration of the critical load parameters: maximum size of the load step,  $\Delta I$ , the load-current slew rate,  $di/dt$ , and the maximum allowable output voltage deviation under transient loading,  $\Delta V_{MAX}$ . Capacitors are characterized according to their capacitance, ESR, and ESL (equivalent series inductance).

At the beginning of the load transient, the output capacitors supply all of the transient current. The output voltage will initially deviate by an amount approximated by the voltage drop across the ESL. As the load current increases, the voltage drop across the ESR increases linearly until the load current reaches its final value. The capacitors selected must have sufficiently low ESL and ESR so that the total output-voltage deviation is less than the allowable maximum. Neglecting the contribution of inductor current and regulator response, the output voltage initially deviates according to Equation 21:

$$\Delta V \approx (\text{ESL}) \frac{di}{dt} + (\text{ESR}) \Delta I \quad (\text{EQ. 21})$$

The filter capacitor must have sufficiently low ESL and ESR so that  $\Delta V < \Delta V_{MAX}$ .

Most capacitor solutions rely on a mixture of high-frequency capacitors with relatively low capacitance in combination with bulk capacitors having high capacitance but limited high-frequency performance. Minimizing the ESL of the high-frequency capacitors allows them to support the output voltage as the current increases. Minimizing the ESR of the bulk capacitors allows them to supply the increased current with less output voltage deviation.

The ESR of the bulk capacitors is also responsible for the majority of the output-voltage ripple. As the bulk capacitors sink and source the inductor ac ripple current, a voltage develops across the bulk-capacitor ESR equal to  $I_{PP}$ . Thus, once the output capacitors are selected and a maximum allowable ripple voltage,  $V_{PP(MAX)}$ , is determined from an analysis of the available output voltage budget, Equation 22 can be used to determine a lower limit on the output inductance.

$$L \geq \text{ESR} \cdot \frac{(V_{IN} - 2 \cdot V_{OUT}) \cdot V_{OUT}}{f_S \cdot V_{IN} \cdot V_{PP(MAX)}} \quad (\text{EQ. 22})$$

Since the capacitors are supplying a decreasing portion of the load current while the regulator recovers from the transient, the capacitor voltage becomes slightly depleted.

The output inductors must be capable of assuming the entire load current before the output voltage decreases more than  $\Delta V_{MAX}$ . This places an upper limit on inductance.

$$L \leq \frac{4 \cdot C \cdot V_{OUT}}{(\Delta I)^2} \cdot (\Delta V_{MAX} - \Delta I \cdot ESR) \quad (\text{EQ. 23})$$

While the previous equation addresses the leading edge, Equation 24 gives the upper limit on L for cases where the trailing edge of the current transient causes a greater output voltage deviation than the leading edge.

$$L \leq \frac{2.5 \cdot C}{(\Delta I)^2} \cdot (\Delta V_{MAX} - \Delta I \cdot ESR) \cdot (V_{IN} - V_O) \quad (\text{EQ. 24})$$

Normally, the trailing edge dictates the selection of L, since duty cycles are usually less than 50%. Nevertheless, both inequalities should be evaluated, and L should be selected based on the lower of the two results. In all equations in this paragraph, L is the per-channel inductance and C is the total output bulk capacitance.

## Layout Considerations

MOSFETs switch very fast and efficiently. The speed with which the current transitions from one device to another causes voltage spikes across the interconnecting impedances and parasitic circuit elements. These voltage spikes can degrade efficiency, radiate noise into the circuit and lead to device overvoltage stress. Careful component layout and printed circuit design minimizes the voltage spikes in the converter. Consider, as an example, the turnoff transition of the upper PWM MOSFET. Prior to turnoff, the upper MOSFET was carrying channel current. During the turnoff, current stops flowing in the upper MOSFET and is picked up by the lower MOSFET. Any inductance in the switched current path generates a large voltage spike during the switching interval. Careful component selection, tight layout of the critical components, and short, wide circuit traces minimize the magnitude of voltage spikes.

There are two sets of critical components in a DC-DC converter using an ISL6563 controller. The power components are the most critical because they switch large amounts of energy. Next are small signal components that connect to sensitive nodes or supply critical bypassing current and signal coupling.

Note that as the ISL6563 does not allow external adjustment of the channel-to-channel current balancing (current information is multiplexed across a single  $R_{ISEN}$  resistor), it is important to have a symmetrical layout, preferably with the controller equidistantly located from the two power trains it controls. Equally important are the gate drive lines (UGATE, LGATE, PHASE): since they drive the power train MOSFETs using short, high current pulses, it is important to size them accordingly and reduce their overall impedance. Equidistant placement of the controller to the two power trains also helps keeping these traces equally long (equal impedances, resulting in similar driving of both sets of MOSFETs).

The power components should be placed first. Locate the input capacitors close to the power switches. Minimize the length of the connections between the input capacitors,  $C_{IN}$ , and the power switches. Locate the output inductors and output capacitors between the MOSFETs and the load. Locate the high-frequency decoupling capacitors (ceramic) as close as practicable to the decoupling target, making use of the shortest connection paths to any internal planes, such as vias to GND immediately next, or even onto the capacitor solder pad.

The critical small components include the bypass capacitors for VCC and PVCC. Locate the bypass capacitors,  $C_{BP}$ , close to the device. It is especially important to locate the components associated with the feedback circuit close to their respective controller pins, since they belong to a high-impedance circuit loop, sensitive to EMI pick-up. It is important to place the  $R_{ISEN}$  resistor close to the respective terminal of the ISL6563.

A multi-layer printed circuit board is recommended. Figure 9 shows the connections of the critical components for one output channel of the converter. Note that capacitors  $C_{XXIN}$  and  $C_{XXOUT}$  could each represent numerous physical capacitors. Dedicate one solid layer, usually the one underneath the component side of the board, for a ground plane and make all critical component ground connections with vias to this layer. Dedicate another solid layer as a power plane and break this plane into smaller islands of common voltage levels. Keep the metal runs from the PHASE terminal to inductor  $L_{OUT}$  short. The power plane should support the input power and output power nodes. Use copper filled polygons on the top and bottom circuit layers for the phase nodes. Use the remaining printed circuit layers for small signal wiring. The wiring traces from the IC to the MOSFETs' gates and sources should be sized to carry at least one ampere of current (0.02" to 0.05").

## Component Selection Guidelines

### Output Capacitor Selection

The output capacitor is selected to meet both the dynamic load requirements and the voltage ripple requirements. The load transient a microprocessor impresses is characterized by high slew rate ( $di/dt$ ) current demands. In general, multiple high quality capacitors of different size and dielectric are paralleled to meet the design constraints.

Should the load be characterized by high slew rates, attention should be particularly paid to the selection and placement of high-frequency decoupling capacitors (MLCCs, typically multi-layer ceramic capacitors). High frequency capacitors supply the initially transient current and slow the load rate-of-change seen by the bulk capacitors. The bulk filter capacitor values are generally determined by the ESR (effective series resistance) and capacitance requirements.

High frequency decoupling capacitors should be placed as close to the power pins of the load, or for that reason, to any decoupling target they are meant for, as physically possible. Attention should be paid as not to add inductance in the circuit board wiring that could cancel the usefulness of these low inductance components. Consult with the manufacturer of the load on specific decoupling requirements.

Use only specialized low-ESR capacitors intended for switching-regulator applications for the bulk capacitors. The bulk capacitor's ESR determines the output ripple voltage and the initial voltage drop following a high slew-rate transient's edge. In most cases, multiple capacitors of small case size perform better than a single large case capacitor.

Bulk capacitor choices include aluminum electrolytic, OS-Con, Tantalum and even ceramic dielectrics. An aluminum

electrolytic capacitor's ESR value is related to the case size with lower ESR available in larger case sizes. However, the equivalent series inductance (ESL) of these capacitors increases with case size and can reduce the usefulness of the capacitor to high slew-rate transient loading. Unfortunately, ESL is not a specified parameter. Consult the capacitor manufacturer and/or measure the capacitor's impedance with frequency to help select a suitable component.

**Output Inductor Selection**

One of the parameters limiting the converter's response to a load transient is the time required to change the inductor current. In a multiphase converter, small inductors reduce the response time with less impact to the total output ripple current (as compared to single-phase converters).

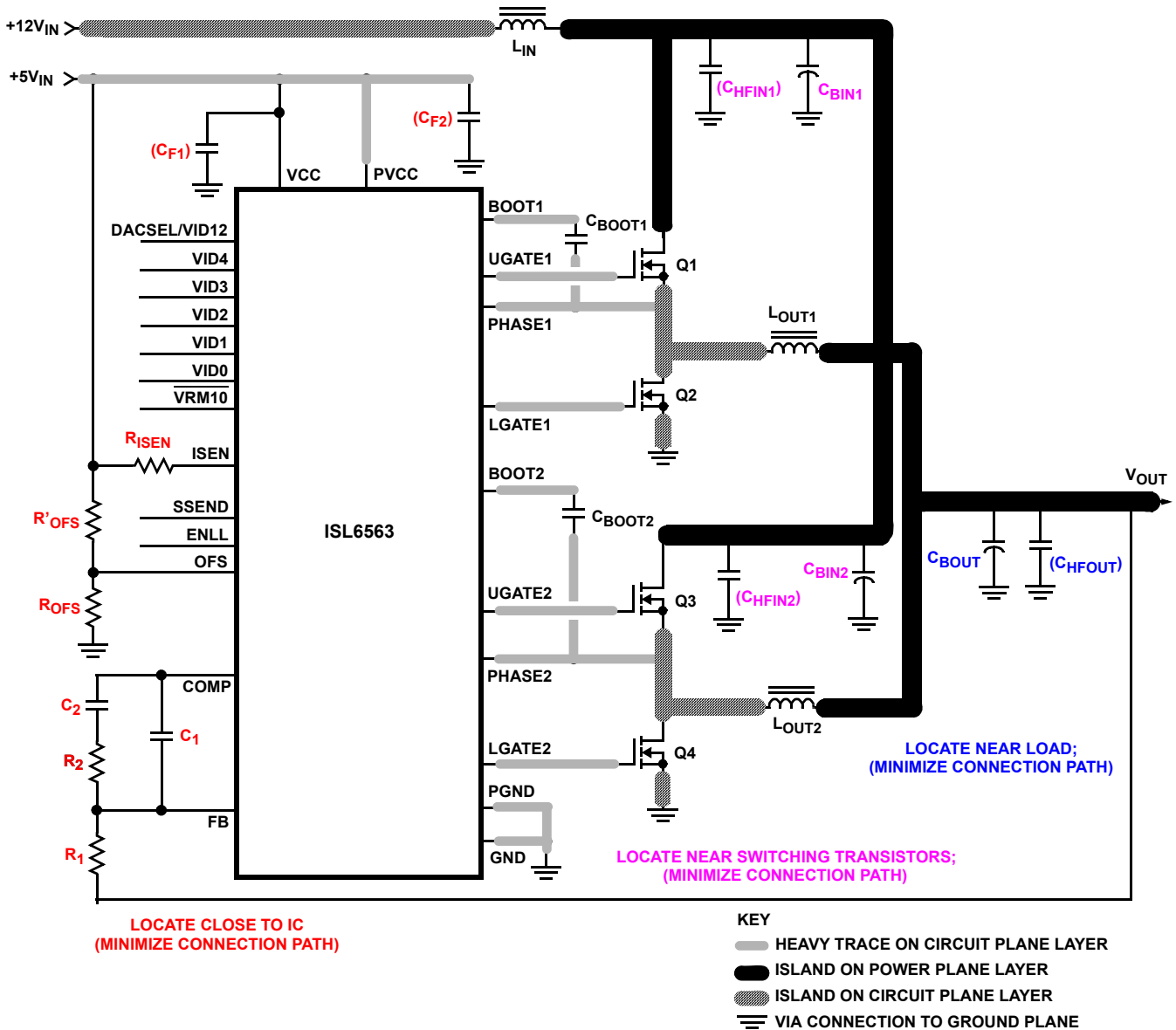

FIGURE 9. PRINTED CIRCUIT BOARD POWER PLANES AND ISLANDS

The output inductor of each power channel controls the ripple current. The control IC is stable for channel ripple current (peak-to-peak) up to twice the average current. A single channel's ripple current is approximated using Equation 25:

$$I_{L,PP} = \frac{V_{IN} - V_{OUT}}{F_{SW} \cdot L} \times \frac{V_{OUT}}{V_{IN}} \quad (\text{EQ. 25})$$

The current from multiple channels tend to cancel each other and reduce the total ripple current. The total output ripple current can be determined using the curve in Figure 10; it provides the total ripple current as a function of duty cycle and number of active channels, normalized to the parameter  $K_{NORM}$  at zero duty cycle.

$$K_{NORM} = \frac{V_{OUT}}{L \cdot F_{SW}} \quad (\text{EQ. 26})$$

where  $L$  is the channel inductor value.

Find the intersection of the active channel curve and duty cycle for your particular application. The resulting ripple current multiplier from the y-axis is then multiplied by the normalization factor,  $K_{NORM}$ , to determine the total output ripple current for the given application.

$$\Delta I_{TOTAL} = K_{NORM} \cdot K_{CM} \quad (\text{EQ. 27})$$

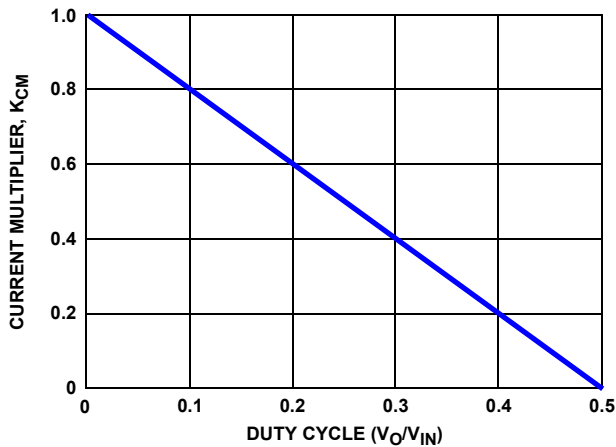

FIGURE 10. RIPPLE CURRENT vs DUTY CYCLE

### Input Capacitor Selection

The important parameters for the bulk input capacitors are the voltage rating and the RMS current rating. For reliable operation, select bulk input capacitors with voltage and current ratings above the maximum input voltage and largest RMS current required by the circuit. The capacitor voltage rating should be at least 1.25 times greater than the maximum input voltage. The input RMS current required for a multiphase converter can be approximated with the aid of Figure 11.

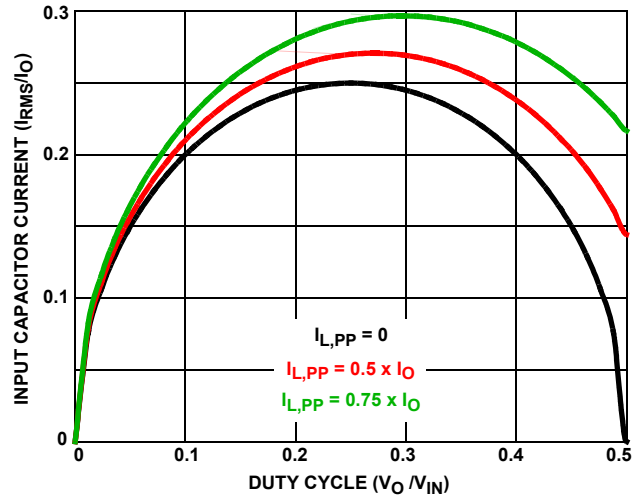

FIGURE 11. NORMALIZED INPUT RMS CURRENT vs DUTY CYCLE FOR A 2-PHASE CONVERTER

As the input capacitors are responsible for sourcing the AC component of the input current flowing into the upper MOSFETs, their RMS current capacity must be sufficient to handle the AC component of the current drawn by the upper MOSFETs. Figure 11 can be used to determine the input capacitor RMS current function of duty cycle, maximum sustained output current ( $I_O$ ), and the ratio of the peak-to-peak inductor current ( $I_{L,PP}$ ) to the maximum sustained load current,  $I_O$ . Figure 11 can also be used as a reference demonstrating the dramatic reduction in input capacitor RMS current in a 2-phase DC/DC converter, as compared to a single-phase regulator.

Use a mix of input bypass capacitors to control the input voltage ripple. Use ceramic capacitance for the high frequency decoupling and bulk capacitors to supply the RMS current. Minimize the connection path inductance of the high frequency decoupling ceramic capacitors (from drain of upper MOSFET to source of lower MOSFET).

For bulk capacitance, several electrolytic or high-capacity MLC capacitors may be needed. For surface mount designs, solid tantalum capacitors can be used, but caution must be exercised with regard to the capacitor surge current rating. These capacitors must be capable of handling the surge-current at power-up.

All Intersil U.S. products are manufactured, assembled and tested utilizing ISO9000 quality systems.

Intersil Corporation's quality certifications can be viewed at [www.intersil.com/design/quality](http://www.intersil.com/design/quality)

*Intersil products are sold by description only. Intersil Corporation reserves the right to make changes in circuit design, software and/or specifications at any time without notice. Accordingly, the reader is cautioned to verify that data sheets are current before placing orders. Information furnished by Intersil is believed to be accurate and reliable. However, no responsibility is assumed by Intersil or its subsidiaries for its use; nor for any infringements of patents or other rights of third parties which may result from its use. No license is granted by implication or otherwise under any patent or patent rights of Intersil or its subsidiaries.*

For information regarding Intersil Corporation and its products, see [www.intersil.com](http://www.intersil.com)

# Package Outline Drawing

## L24.4x4B

24 LEAD QUAD FLAT NO-LEAD PLASTIC PACKAGE

Rev 3, 4/10

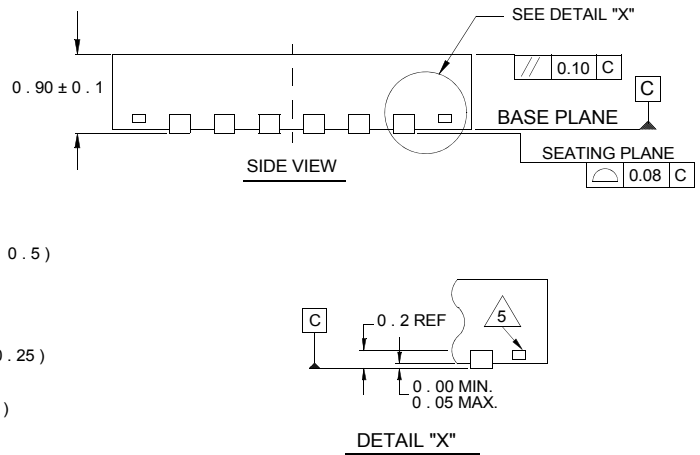
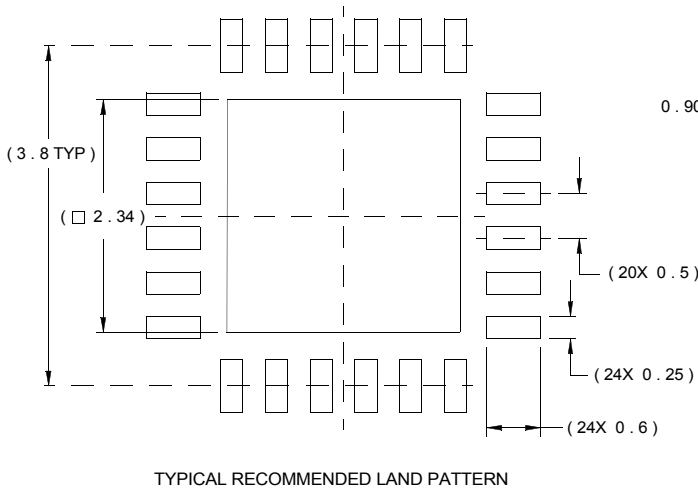
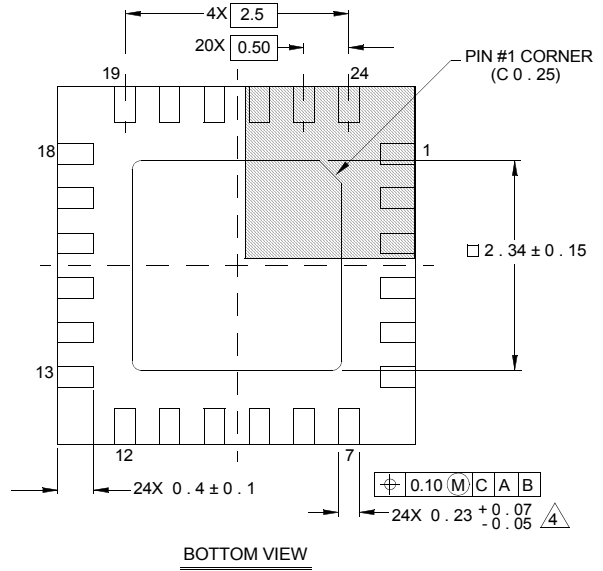
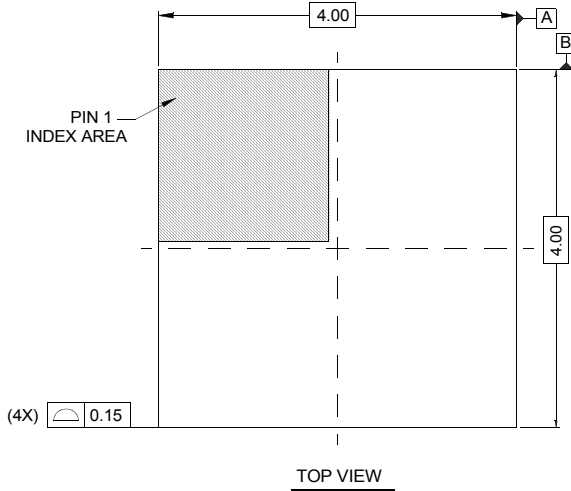

### NOTES:

1. Dimensions are in millimeters.  
Dimensions in ( ) for Reference Only.
2. Dimensioning and tolerancing conform to AMSE Y14.5m-1994.
3. Unless otherwise specified, tolerance : Decimal  $\pm 0.05$
4. Dimension applies to the metallized terminal and is measured between 0.15mm and 0.30mm from the terminal tip.
5. Tiebar shown (if present) is a non-functional feature.
6. The configuration of the pin #1 identifier is optional, but must be located within the zone indicated. The pin #1 identifier may be either a mold or mark feature.