



Chipsmall Limited consists of a professional team with an average of over 10 year of expertise in the distribution of electronic components. Based in Hongkong, we have already established firm and mutual-benefit business relationships with customers from,Europe,America and south Asia,supplying obsolete and hard-to-find components to meet their specific needs.

With the principle of “Quality Parts,Customers Priority,Honest Operation,and Considerate Service”,our business mainly focus on the distribution of electronic components. Line cards we deal with include Microchip,ALPS,ROHM,Xilinx,Pulse,ON,Everlight and Freescale. Main products comprise IC,Modules,Potentiometer,IC Socket,Relay,Connector.Our parts cover such applications as commercial,industrial, and automotives areas.

We are looking forward to setting up business relationship with you and hope to provide you with the best service and solution. Let us make a better world for our industry!



## Contact us

Tel: +86-755-8981 8866 Fax: +86-755-8427 6832

Email & Skype: info@chipsmall.com Web: www.chipsmall.com

Address: A1208, Overseas Decoration Building, #122 Zhenhua RD., Futian, Shenzhen, China



## Complementary MOSFET Driver and Synchronous Half-Bridge Switch

The Intersil ISL6571 provides a new approach for implementing a synchronous rectified buck switching regulator. The ISL6571 replaces two power MOSFETs, a Schottky diode, two gate drivers and synchronous control circuitry. Its main applications address high-density power conversion circuits including multiphase-topology computer microprocessor core power regulators, ASIC and memory array regulators, etc. Another useful feature of the ISL6571 is the compatibility with three-state input control: left open, the PWM input turns off both output drives. The ISL6571 operates in continuous conduction mode reducing EMI constraints and enabling high bandwidth operation.

### Ordering Information

PART NUMBER	TEMP. RANGE (°C)	PACKAGE	PKG. DWG. #
ISL6571CR*	0 to 70	68 Ld 10x10 QFN	L68.10x10A
ISL6571CRZ* (See Note)	0 to 70	68 Ld 10x10 QFN (Pb-free)	L68.10x10A
ISL6571EVAL1	Evaluation Board		

\*Add "-T" suffix for tape and reel.

NOTE: Intersil Pb-free products employ special Pb-free material sets; molding compounds/die attach materials and 100% matte tin plate termination finish, which are RoHS compliant and compatible with both SnPb and Pb-free soldering operations. Intersil Pb-free products are MSL classified at Pb-free peak reflow temperatures that meet or exceed the Pb-free requirements of IPC/JEDEC J STD-020.

### Features

- Improved Performance over Conventional Synchronous Buck Converter using Discrete Components
- Optimal Deadtime Provided by Adaptive Shoot-Through
- Switching Frequency up to 1MHz
  - High-Bandwidth, Fast Transient Response
  - Small, Low Profile Converters
- Reduced Connection Parasitics between Discrete Components
  - Low Electromagnetic Emissions
- Low Profile, Low Thermal Impedance Packaging
  - High Power Density Applications
- QFN Package:
  - Compliant to JEDEC PUB95 MO-220 QFN - Quad Flat No Leads - Package Outline
  - Near Chip Scale Package footprint, which improves PCB efficiency and has a thinner profile
- Pb-Free Available (RoHS Compliant)

### Applications

- Multiphase Power Regulators
- Low-Voltage Switchmode Power Conversion
- High-Density Power Converters

# ISL6571

## Pinout

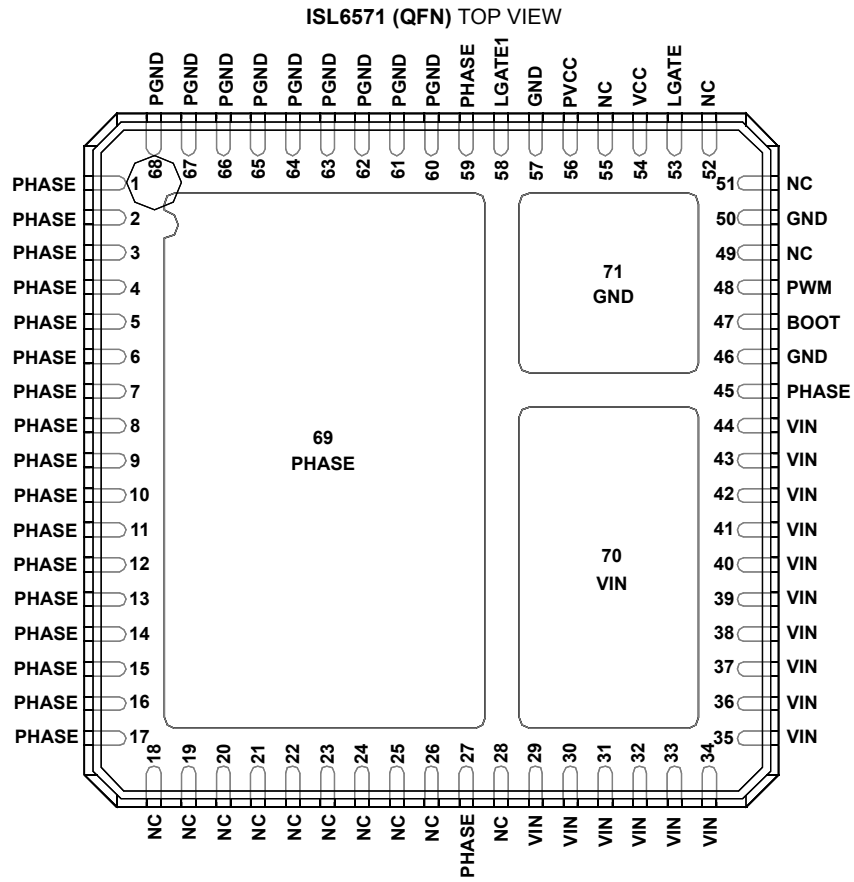

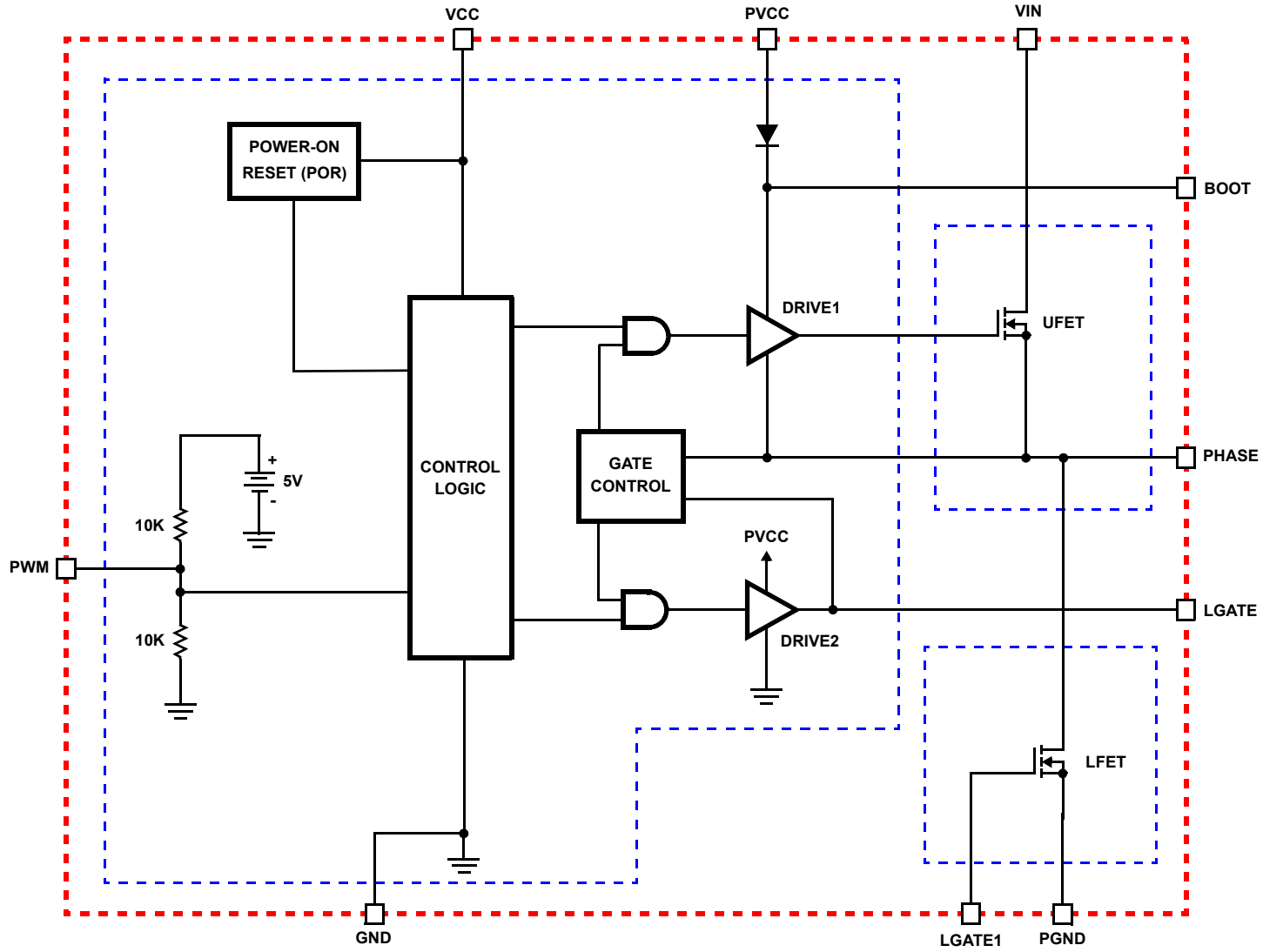

FIGURE 1. BLOCK DIAGRAM

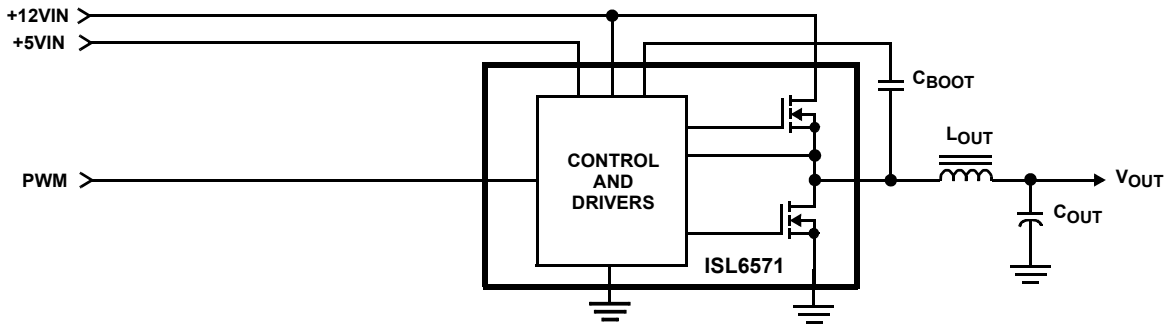

FIGURE 2. SIMPLIFIED POWER SYSTEM DIAGRAM

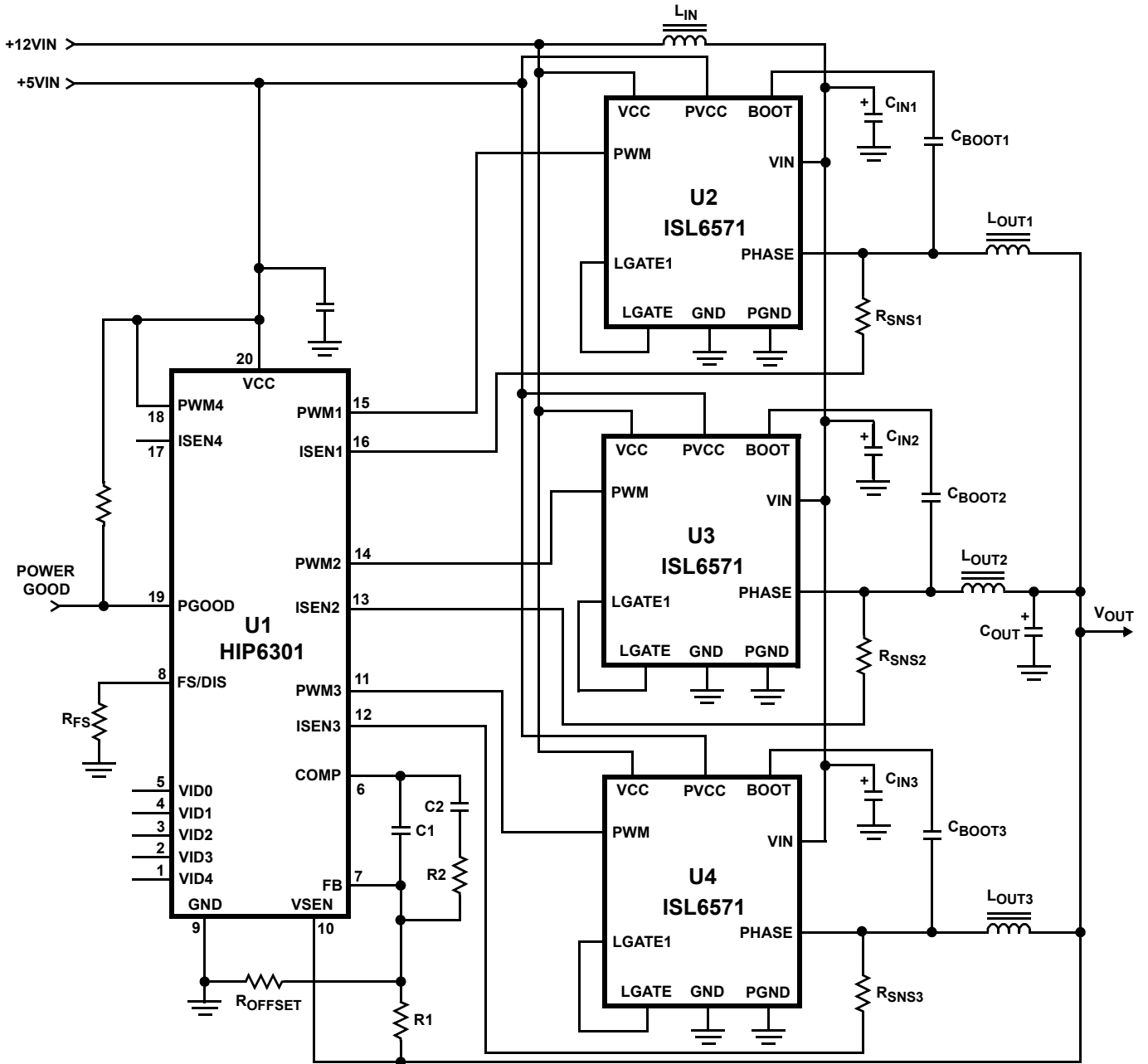

FIGURE 3. TYPICAL APPLICATION

**Absolute Maximum Ratings**

Bias Supply Voltage, VCC	+15V
Driver Supply, PVCC	+10.5V
Conversion Voltage, VIN	VCC+0.3V
DRIVE1 Voltage, V <sub>BOOT</sub> - V <sub>PHASE</sub>	+15V
Input Voltage, PWM	GND -0.3V to 7V
ESD Classification	Class 2

**Thermal Information**

Thermal Resistance (Typical, Note 1)	$\theta_{JC}$ (°C/W)
Pad 69	1.3
Pad 70	4.0
Pad 71	6.0
Maximum Junction Temperature	125°C
Maximum Storage Temperature Range	-40°C to 125°C
Maximum Lead Temperature (Soldering 10s)	300°C

**Recommended Operating Conditions**

Control and Conversion Voltage, VCC, VIN	+12V ±10%
MOSFET Bias Supply, PVCC	+5V to +10V
Ambient Temperature Range	0°C to 70°C
Junction Temperature Range	0°C to 125°C

CAUTION: Stresses above those listed in "Absolute Maximum Ratings" may cause permanent damage to the device. This is a stress only rating and operation of the device at these or any other conditions above those indicated in the operational sections of this specification is not implied.

## NOTE:

- $\theta_{JC}$  is measured with the component mounted on a typical application PCB. A separate  $\theta_{JC}$  value is provided for each of the three exposed die pads (#69, 70, 71). Each value should be used in combination with the power dissipated by only the individual die mounted on that pad.

**Electrical Specifications** Recommended Operating Conditions, Unless Otherwise Noted. Refer to Figures 1, 2 and 3

PARAMETER	SYMBOL	TEST CONDITIONS	MIN	TYP	MAX	UNITS
<b>SUPPLY CURRENT</b>						
Nominal Bias Supply Current	I <sub>VCC</sub>	PWM Open	-	2.5	3.6	mA
<b>POWER-ON RESET</b>						
Rising VCC Threshold			9.70	9.95	10.40	V
VCC Threshold Hysteresis			-	2.40	-	V
<b>MOSFET DRIVER</b>						
Input Impedance	Z <sub>IN</sub>		-	5	-	k $\Omega$
PWM Rising Threshold			-	-	3.80	V
PWM Falling Threshold			1.30	-	-	V
PWM-to-PHASE Low-to-High Propagation Delay	t <sub>PLH</sub>		-	80	-	ns
PWM-to-PHASE High-to-Low Propagation Delay	t <sub>PHL</sub>		-	56	-	ns
Shutdown Window			1.60	-	3.40	V
Shutdown Holdoff Time	t <sub>SH</sub>		-	230	-	ns
<b>UPPER MOSFET (UFET)</b>						
Drain-to-Source ON-State Resistance	r <sub>DS(ON)</sub>	V <sub>BOOT</sub> - V <sub>PHASE</sub> = 5V	12.8	13.5	18.2	m $\Omega$
		V <sub>BOOT</sub> - V <sub>PHASE</sub> = 10V	7.70	9.20	12.7	m $\Omega$
ON-State Drain Current		V <sub>BOOT</sub> - V <sub>PHASE</sub> = 5V	25	-	-	A
<b>LOWER MOSFET (LFET)</b>						
Drain-to-Source ON-State Resistance	r <sub>DS(ON)</sub>	V <sub>PVCC</sub> = 5V	4.10	4.80	5.55	m $\Omega$
		V <sub>PVCC</sub> = 10V	3.40	4.05	4.70	m $\Omega$
ON-State Drain Current		V <sub>PVCC</sub> = 5V	25	-	-	A

Typical Performance Curves/Setup

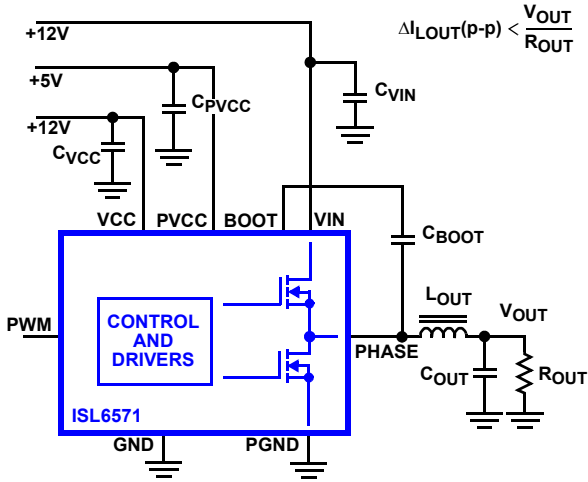

FIGURE 4. TYPICAL TEST CIRCUIT

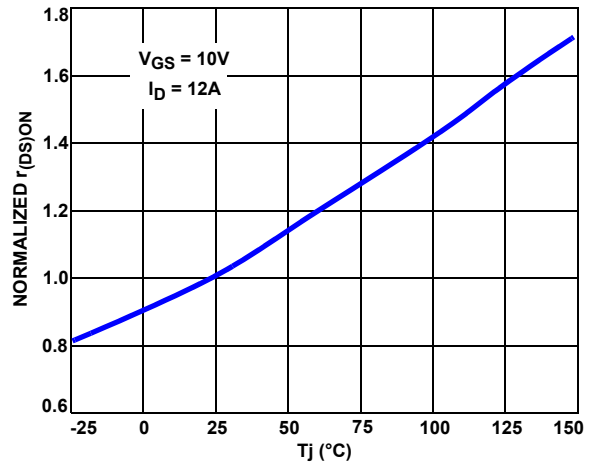

FIGURE 5. UPPER MOSFET ON RESISTANCE vs TEMPERATURE

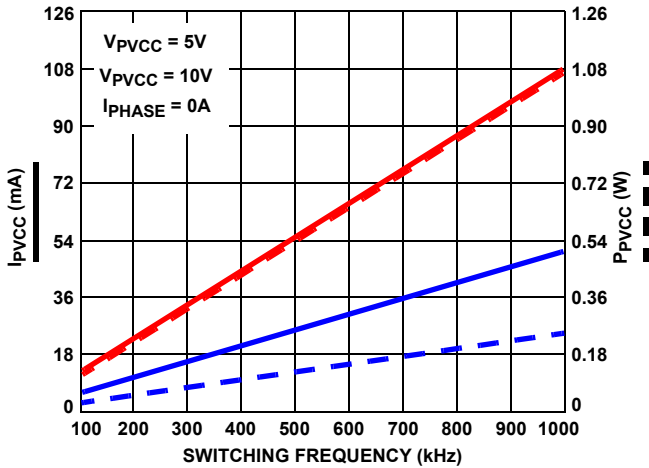

FIGURE 6. BIAS SUPPLY CURRENT/POWER vs FREQUENCY

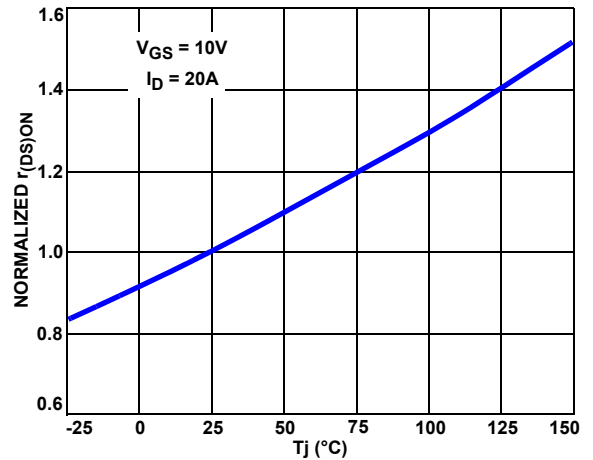

FIGURE 7. LOWER MOSFET ON RESISTANCE vs TEMPERATURE

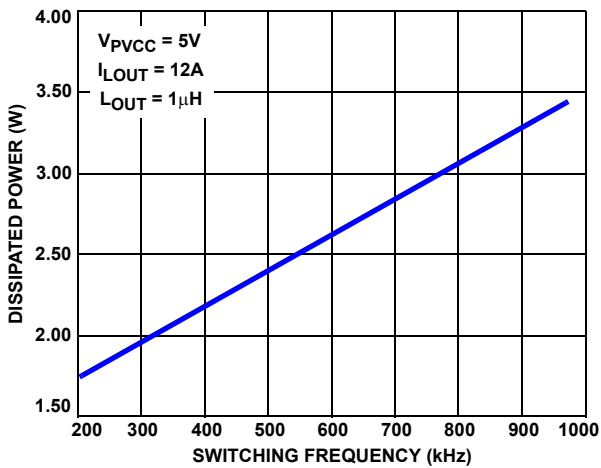

FIGURE 8. ISL6571 POWER DISSIPATION vs FREQUENCY AT 12A

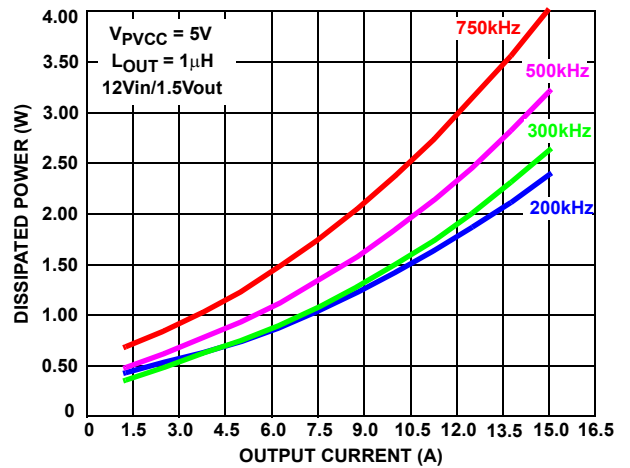

FIGURE 9. ISL6571 POWER DISSIPATION vs CURRENT AT 200kHz, 300kHz, 500kHz, 750kHz

## Typical Performance Curves/Setup (Continued)

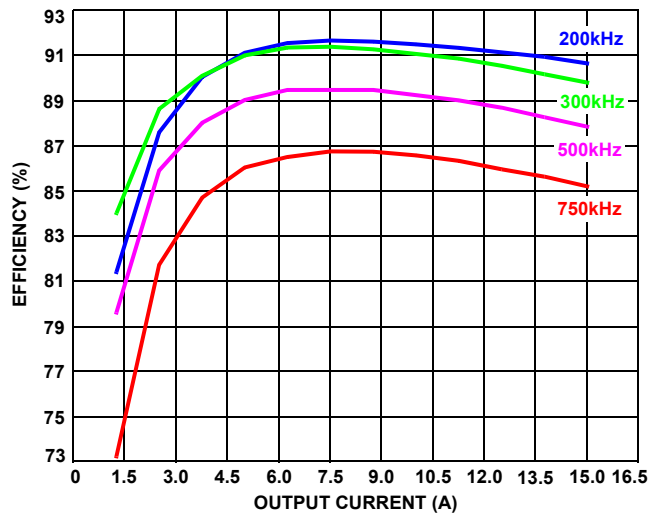

FIGURE 10. ISL6571 EFFICIENCY AT 200kHz, 300kHz, 500kHz, 750kHz

## Functional Pin Descriptions

### VCC (Pin 54)

Provide a 12V bias supply for the driver IC to this pin. The voltage at this pin is monitored for Power-On Reset (POR) purposes.

### PVCC (Pin 56)

Provide a well decoupled 5V to 10V bias supply at this pin. The voltage at this pin is used to bias the gates of the MOSFET switches.

### GND (Pins 46, 50, 57, 71)

Ground pins for the driver IC. Connect these pins to the circuit ground (plane) and to the PGND pins using the shortest available paths.

### PGND (Pins 60-68)

This is the source ground connection for the lower MOSFET switches. Connect these pins to the circuit ground (plane) and to the GND pins using the shortest available paths.

### VIN (Pins 29-44, 70)

Connect these pins to the input voltage to be converted down. Provide bulk and high-frequency decoupling capacitors as close to these pins as feasible.

### PHASE (Pins 1-17, 27, 45, 59, 69)

As a minimum, connect pin 69 to the output inductor. The remainder of the PHASE pins may be tied to pin 69, left open, or used for other connections. It is recommended pin 45 is connected to the bootstrap capacitor,  $C_{BOOT}$ .

### BOOT (Pin 47)

This pin is connected to the PVCC pin through an internal quasi-diode. Connect a bootstrap capacitor from this pin to PHASE pin 45 (0.1 $\mu$ F recommended). This capacitor

provides the bias for the upper MOSFET drive and the gate charge for the upper MOSFET.

### LGATE (Pin 53)

This pin is the output of the lower MOSFET drive. Connect this pin to LGATE1 pin using the shortest available path.

### LGATE1 (Pin 58)

This pin is connected to the gate of the lower MOSFET switch. Connect this pin to LGATE pin using the shortest available path.

### PWM (Pin 48)

Connect this pin to the regulating controller's PWM output. Left open, this input will float to approximately 2.5V and cause both MOSFET switches to be turned off. Applying 5V to this input causes the upper MOSFET switch to be turned on. A 0V applied to this input causes the lower MOSFET switch to be turned on. The approximate input impedance of this pin is 5k $\Omega$ .

### NC (Pins 18-26, 28, 49, 51, 52, 55)

These pins are not internally connected.

## Description

### Bias Requirements

The on-board driver includes a Power-On Reset (POR) function, which continually monitors the input bias supply. The POR monitors the bias voltage (+12V<sub>IN</sub>) at the VCC pin, and enables the ISL6571 for operation immediately after it exceeds the rising threshold. Upon the bias voltage's drop below the falling threshold, the IC is disabled and both internal MOSFETs are turned off.

The output drivers are powered from the PVCC pin. For proper functionality and driving capability, connect PVCC to



a suitable supply, 5V to 10V, no higher than the voltage applied at the VCC pin. The higher the voltage applied at the PVCC pin, the better the channel enhancement of the on-board power MOSFETs, but also the higher the power dissipated inside the driver.

The down-conversion voltage applied at VIN cannot exceed the bias voltage applied at VCC, but can be as low as practically possible.

### Operation

The ISL6571 combines two MOSFET transistors in a synchronous buck power train configuration, along with a half-bridge MOSFET driver designed to control these two MOSFETs. When reviewing the operational details, refer to Figure 5 test setup.

With all requirements for operation met, a logic high signal on the PWM pin causes the UFET to turn on, while a logic low signal applied to the PWM pin causes LFET to turn on. If the PWM input is driven within the shutdown window and remains there for the minimum holdoff time specified (See 'Electrical Specifications'), both MOSFETs are turned off.

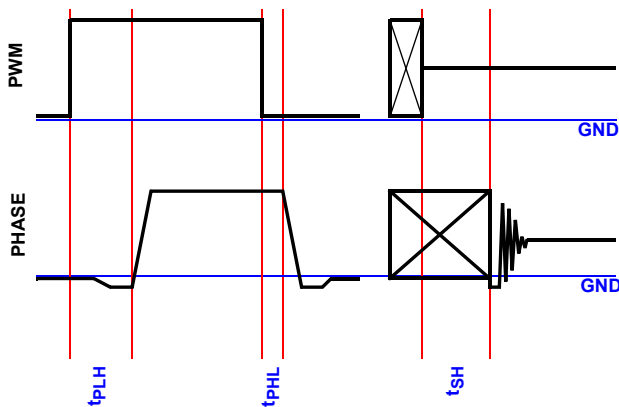

FIGURE 11. PHASE RESPONSE TO PWM INPUT

At the transition between the on intervals of the two MOSFETs, the internal driver acts in a 'break-before-make' fashion. Thus, the driver monitors the on device and turns on the (previously) off device, following a short time delay after the on MOSFET has turned off. This behavior is necessary to insure the absence of cross-conduction (shoot-through) amongst the two MOSFETs.

## Application and Component Selection Guidelines

### Layout Considerations

MOSFETs switch very fast and efficiently. The speed with which the current transitions from one device to another causes voltage spikes across the interconnecting impedances and parasitic circuit elements. The voltage spikes can degrade efficiency, radiate noise into the circuit, and lead to device overvoltage stress. Careful component

layout and printed circuit design minimizes the voltage spikes in the converter. Consider, as an example, the turn-off transition of the upper MOSFET. Prior to turn-off, the upper MOSFET was carrying the full load current. During the turn-off, current stops flowing in the upper MOSFET and is picked up by the lower MOSFET or Schottky diode. Any inductance in the switched current path generates a large voltage spike during the switching interval. Careful component selection, tight layout of the critical components, and short, wide circuit traces minimize the magnitude of voltage spikes.

The ISL6571 is the first step in such an efficient design. By bringing the driver and switching transistors in close proximity, most of the interconnect/layout parasitic inductances are greatly reduced. However, these benefits are nullified if the associated decoupling elements and other circuit components are not carefully positioned and laid out to help the ISL6571 realize its full potential. Figure 12 shows one possible layout pattern, detailing preferred positioning of components, land size/pattern, and via count. Figure 12 is one of many possible layouts yielding good results; use it for general illustration and guidance.

Locate the decoupling capacitors, especially the high-frequency ceramic capacitors, close to the ISL6571. To fully exploit ceramic capacitors' low equivalent series inductance (ESL), insure their ground connection is made as close to their grounded terminal as physically feasible. Figure 12 details via-in-pad (VIP) practices, where the via is placed on the component's landing pad, thus yielding the shortest-path, lowest ESL connection to the desired plane/island.

Via-in-pad design is very important to the layout of the ISL6571, since it is an integral part of the thermal design consideration. VIP not only provides the lowest ESL circuit connections, but it is essential to the propagation of heat from the internal dies to the ambient. The vias placed directly underneath the bottom pads of the package provide a low thermal impedance path for the heat generated inside the IC to diffuse through the internal planes, as well as through islands on the back side of the board. Layout with landing pads for the bottom pads of the package devoid of vias is possible (rather, with vias placed outside of the package outline), but the thermal performance of such a layout would be significantly reduced. Use the smallest diameter vias available and avoid the use of thermal relief on the contacts with internal planes; if thermal relief is mandatory on all vias, design the thermal relief so that it voids the smallest possible copper area around the vias (thus preserving thermal conductivity and reducing electrical contact resistance).

A multi-layer printed circuit board is recommended. Dedicate one solid layer for a ground plane and make all critical component ground connections with vias to this layer. Dedicate another solid layer as a power plane and break this plane into smaller islands of common voltage levels. The power plane should support the input power and output power nodes.

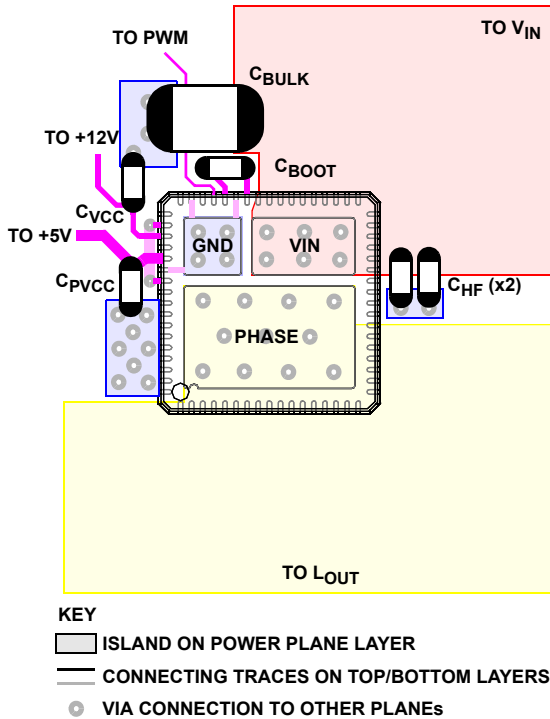

**FIGURE 12. PRINTED CIRCUIT BOARD POWER PLANES AND ISLANDS**

Use copper-filled polygons on the top and bottom circuit layers for the PHASE node, but do not unnecessarily oversize these particular islands. Since the PHASE node is subject to very high  $dV/dt$  voltages, the stray capacitors formed between these islands and the surrounding circuitry or internal planes will tend to couple switching noise. On the other hand, these islands have to be sufficiently large to offer a good path to surrounding environment for the heat produced inside the ISL6571.

Use the remaining printed circuit layers for small signal wiring. The wiring traces from the surrounding application to the ISL6571 should be sized according to their task. Thus, small-signal traces, like the PWM signal or the ISEN feedback (if used in conjunction with another Intersil controller), only need be as wide as 5-10mils. Traces carrying bias current should be larger, proportionately with the current flowing through them; for example, traces carrying PVCC current around 50-100mA would require 30-50mils. Generally, the best connections are the shortest, enclosing the least amount of area possible. Similarly, from a conduction requirement perspective, where vias are required to carry current, use a via for each 2-3A of RMS current.

### **Bootstrap Requirements**

The ISL6571 features an integrated boot element connected between the PVCC and BOOT pins. A 0.1 $\mu$ F external bootstrap capacitor is recommended.

### **Capacitor (Decoupling) Selection**

To fully extract the benefits of a highly performant power integrated circuit, the circuit elements surrounding it must conform to the same high standards as the active power element. As such, the capacitors used for high-frequency decoupling of the ISL6571 should be good quality ceramic, with a low ESR and ESL (X7R, X5R dielectric, and 0805 or smaller footprints recommended); a minimum of two 1 $\mu$ F capacitors are recommended. Bulk decoupling capacitor technology is not restricted to ceramic, as electrolytic capacitors are also suitable. For best results, select capacitors based on the input RMS current draw of the circuit, with a low ESL; distribute evenly amongst and place them as close to the ISL6571 as possible.

### **ISL6571 DC-DC Converter Application Circuit**

Figure 13 shows an application circuit of a power supply for a microprocessor computer system. For detailed information on the circuit, including a Bill-of-Materials and circuit board description, contact Intersil to order the evaluation kit ISL6571EVAL1. Also see Intersil web page (<http://www.intersil.com>).

All Intersil U.S. products are manufactured, assembled and tested utilizing ISO9000 quality systems. Intersil Corporation's quality certifications can be viewed at [www.intersil.com/design/quality](http://www.intersil.com/design/quality)

*Intersil products are sold by description only. Intersil Corporation reserves the right to make changes in circuit design, software and/or specifications at any time without notice. Accordingly, the reader is cautioned to verify that data sheets are current before placing orders. Information furnished by Intersil is believed to be accurate and reliable. However, no responsibility is assumed by Intersil or its subsidiaries for its use; nor for any infringements of patents or other rights of third parties which may result from its use. No license is granted by implication or otherwise under any patent or patent rights of Intersil or its subsidiaries.*

For information regarding Intersil Corporation and its products, see [www.intersil.com](http://www.intersil.com)

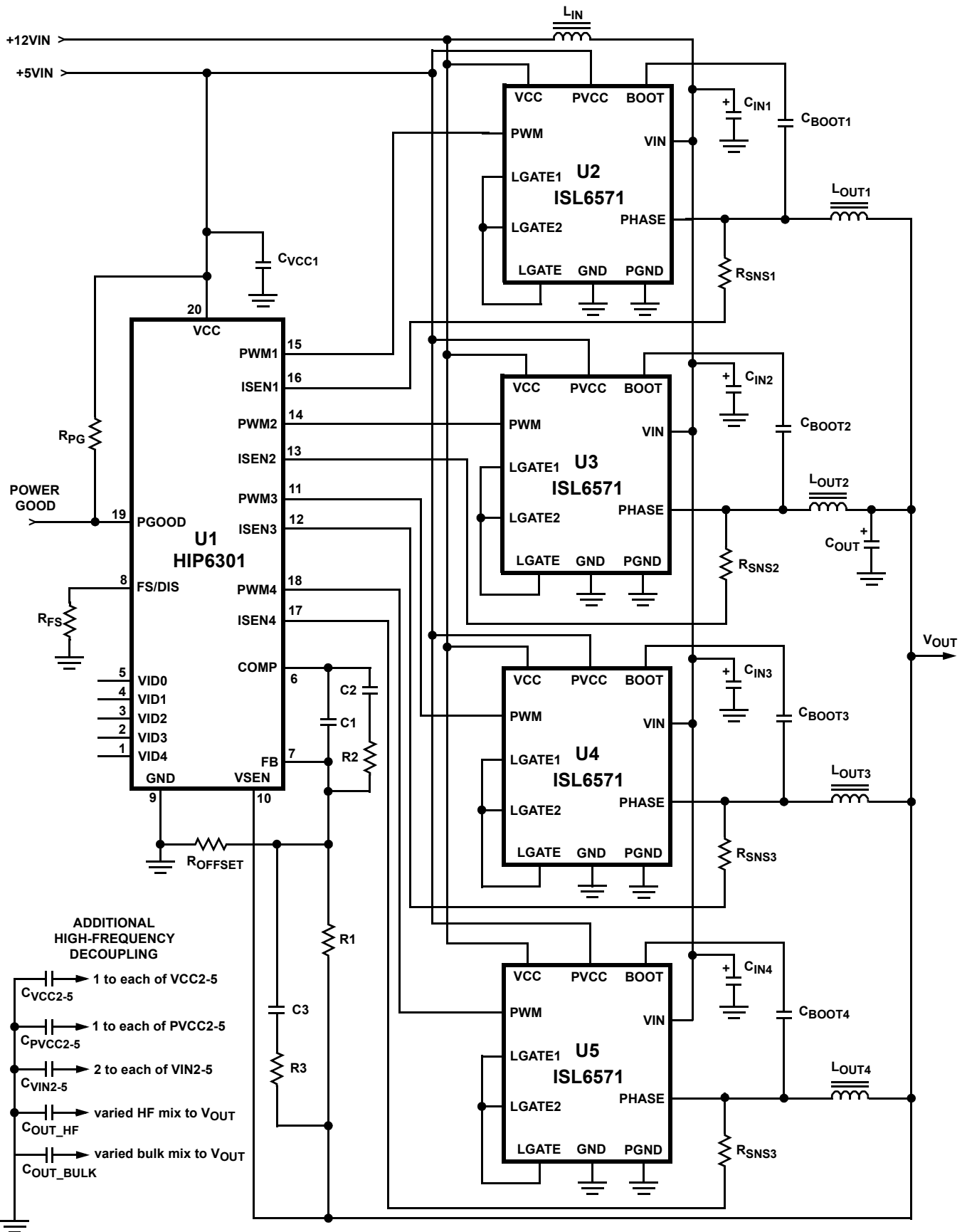
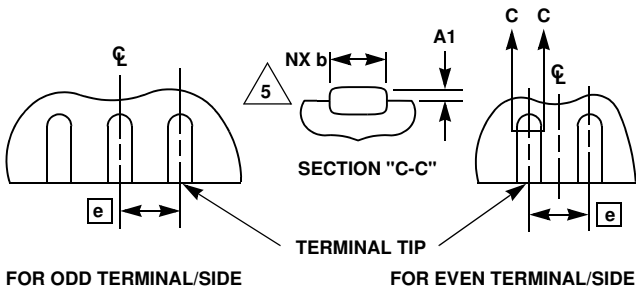
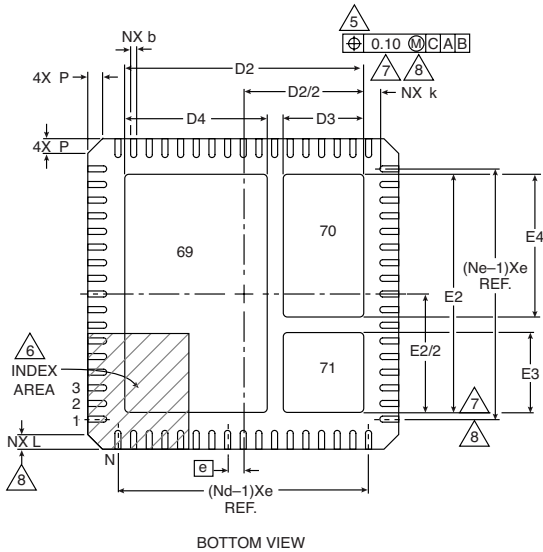
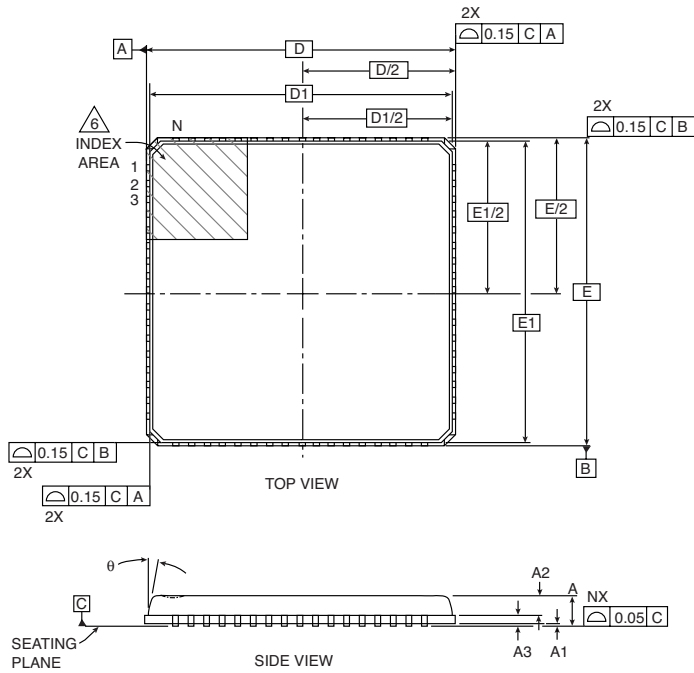

FIGURE 13. TYPICAL ISL6571 APPLICATION CIRCUIT

**Quad Flat No-Lead Plastic Package (QFN)  
Micro Lead Frame Plastic Package (MLFP)**

**L68.10x10A**  
68 LEAD MICRO LEAD FRAME PLASTIC PACKAGE  
(CUSTOMIZED WITH THREE EXPOSED PADS)



SYMBOL	MILLIMETERS			NOTES
	MIN	NOMINAL	MAX	
A	-	-	0.90	-
A1	-	-	0.05	-
A2	-	-	0.70	-
A3	0.20 REF			-
b	0.18	0.23	0.30	5, 8
D	10.00 BSC			-
D1	9.75 BSC			-
D2	7.55	7.70	7.85	7, 8
D3	2.44	2.59	2.74	7, 8
D4	4.48	4.63	4.78	7, 8
E	10.00 BSC			-
E1	9.75 BSC			-
E2	7.55	7.70	7.85	7, 8
E3	2.44	2.59	2.74	7, 8
E4	4.48	4.63	4.78	7, 8
e	0.50 BSC			-
k	0.25	-	-	-
L	0.50	0.60	0.75	8
N	68			2
Nd	17			3
Ne	17			3
P	-	-	0.60	-
theta	-	-	12	-

Rev. 0 2/02

NOTES:

1. Dimensioning and tolerancing per ASME Y14.5-1994.
2. N is the number of peripheral terminals. Exposed pads are terminals 69, 70 and 71, as shown.
3. Nd is the number of terminals in the X direction, and Ne is the number of terminals in the Y direction.
4. Controlling dimension: Millimeters. Angles are in degrees.
5. Dimension b applies to the plated terminal and is measured between 0.20mm and 0.25mm from the terminal tip.
6. The configuration of the pin #1 identifier is optional, but must be located within the zone indicated. The pin #1 identifier may be either a molded or marked feature.
7. Dimensions D2/3/4 and E2/3/4 are for the three exposed pads which provide improved electrical and thermal performance.
8. Nominal dimensions provided to assist with PCB Land Pattern Design efforts, see Technical Brief TB389.