



Chipsmall Limited consists of a professional team with an average of over 10 year of expertise in the distribution of electronic components. Based in Hongkong, we have already established firm and mutual-benefit business relationships with customers from,Europe,America and south Asia,supplying obsolete and hard-to-find components to meet their specific needs.

With the principle of "Quality Parts,Customers Priority,Honest Operation,and Considerate Service",our business mainly focus on the distribution of electronic components. Line cards we deal with include Microchip,ALPS,ROHM,Xilinx,Pulse,ON,Everlight and Freescale. Main products comprise IC,Modules,Potentiometer,IC Socket,Relay,Connector.Our parts cover such applications as commercial,industrial, and automotives areas.

We are looking forward to setting up business relationship with you and hope to provide you with the best service and solution. Let us make a better world for our industry!



Contact us

Tel: +86-755-8981 8866 Fax: +86-755-8427 6832

Email & Skype: info@chipsmall.com Web: www.chipsmall.com

Address: A1208, Overseas Decoration Building, #122 Zhenhua RD., Futian, Shenzhen, China



ISL80510EVAL1Z Evaluation Board User Guide

Description

The ISL80510EVAL1Z provides a simple platform to evaluate performances of the [ISL80510](#) and ISL80505. It comes with jumpers to provide an easy way to set popular output voltages.

The ISL80510 is a high performance, low voltage, high current, low dropout linear regulator specified at 1A. Rated for input voltages from 2.2V to 6V, the LDO can provide output voltages from 0.8V to 5.5V.

Specifications

This board has been configured and optimized for the following operating conditions:

- V_{IN} = 2.2 to 6V (ISL80510), 1.8V to 6V (ISL80505)
- V_{OUT} = 1V, 1.2V, 1.8V, 2.5V, 3.3V, or 5V (Jumper selectable)
- I_{MAX} = 1A (ISL80510), 500mA (ISL80505)

Key Features

- Small, compact design
- V_{IN} range of 2.2V to 6V (ISL80510), 1.8V to 6V (ISL80505)
- V_{OUT} adjustable from 0.8V to 5.5V
- Convenient power connection

References

[ISL80510](#) datasheet

[ISL80505](#) datasheet

Ordering Information

PART NUMBER	DESCRIPTION
ISL80510EVAL1Z	ISL80510 evaluation board

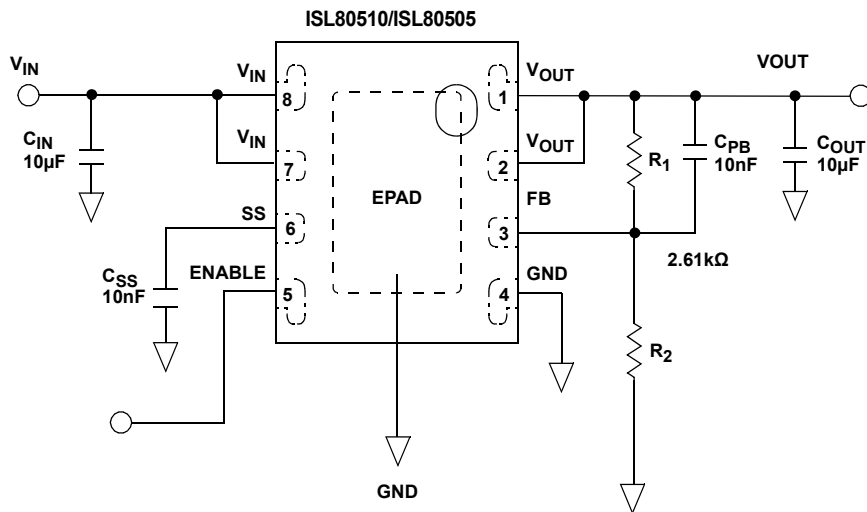

FIGURE 1. ISL80510EVAL1Z BLOCK DIAGRAM

NOTE: The ISL80505 is another high performance, low dropout linear regulator specified at 500mA in the same family as ISL80510. The ISL80505 is rated for input voltage from 1.8V to 6V and can provide output voltages from 0.8V to 5.5V. The ISL80505 is pin-to-pin compatible with ISL80510 and can simply replace ISL80510 on ISL80510EVAL1Z for evaluation. (For ISL80505 samples, please contact Intersil.)

Functional Description

The ISL80510EVAL1Z evaluation board provides a simple platform to demonstrate the features of the ISL80510 and ISL80505. The ISL80510EVAL1Z has a functionally optimized ISL80510/ISL80505 circuit layout that allows efficient operation up to the maximum output current.

The ISL80510EVAL1Z evaluation board is shown in [Figures 2 and 3](#). The [“ISL80510EVAL1Z Circuit Schematic” on page 4](#) shows the schematic, bill of materials and PCB layers for reference. [Figure 7](#) through [16](#) show performance data taken using this hardware.

Operating Range

The board V_{IN} range is 2.2V to 6V (ISL80510) or 1.8V to 6V (ISL80505). The board V_{OUT} setting is set to 1.8V out of the box. The output voltage can be set by an external resistor divider network. The values of resistors R_1 and R_2 can be calculated by using [Equation 1](#).

$$R_1 = R_2 \times \left(\frac{V_{OUT}}{0.5} - 1 \right) \quad (\text{EQ. 1})$$

The output voltage can be easily changed to different voltage setting by jumpers from J1 through J6. [Table 1](#) lists the output voltage options included in the ISL80510EVAL along with the corresponding jumper.

TABLE 1.

V_{OUT} (V)	R_1 (k Ω)	R_2 (k Ω)	JUMPER
1.0	2.61	2.61	J1
1.2	2.61	1.87	J2
1.8	2.61	1.00	J3
2.5	2.61	0.649	J4
3.3	2.61	0.464	J5
5.0	2.61	0.287	J6

PCB Layout Guidelines

A good PCB layout is important to achieve expected performance. Consideration should be taken when placing the components and routing the trace to minimize the ground impedance, and keep the parasitic inductance low. The input and output capacitors should have a good ground connection and be placed as close to the IC as possible. The 'FB' trace must be away from noisy planes and traces.

The large 2x3 via pattern under the ISL80510/ISL80505 is connected to a large ground copper plane on the bottom layer for effective thermal dissipation.

Quick Start Guide

1. Select the desired output voltage by shorting one of the jumpers from J1 through J6.
2. Connect the input supply to VIN and GND.
3. Connect the load to VOUT and GND.
4. Enable the IC using jumper JP1 and observe the output.

ISL80510EVAL1Z Evaluation Board

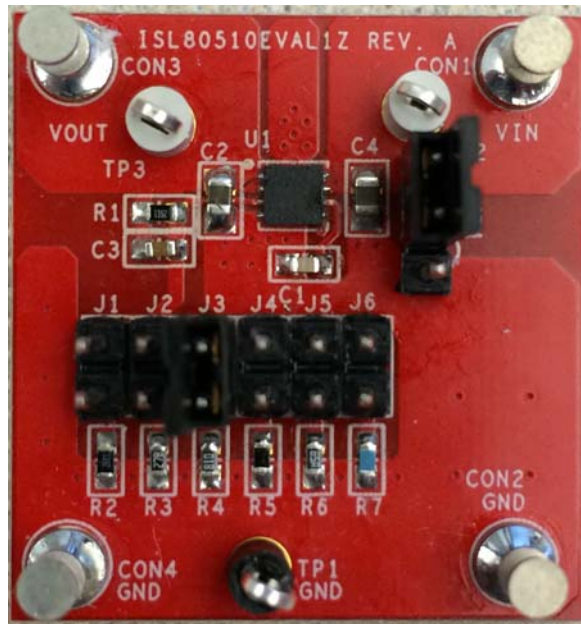

FIGURE 2. TOP SIDE



FIGURE 3. BOTTOM SIDE

ISL80510EVAL1Z Circuit Schematic

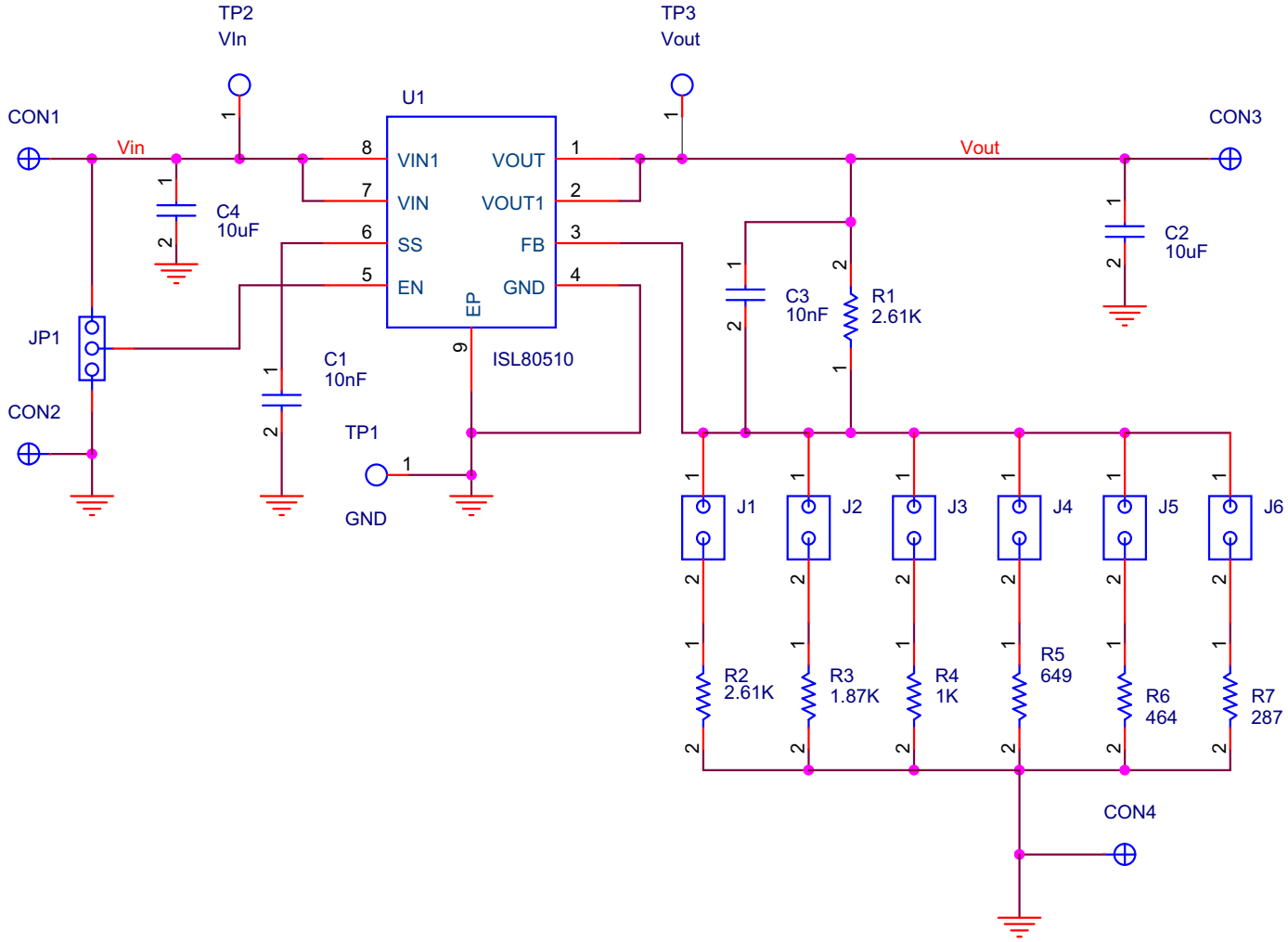

FIGURE 4. ISL80510EVAL1Z SCHEMATIC

User Guide 044

Bill of Materials

ITEM	QTY	REFERENCE DESIGNATOR	VALUE	TOL (%)	RATING	TYPE	PCB FOOTPRINT	MANUFACTURER	MANUFACTURER PART NUMBER
1	2	C1, C3	10nF	5	25V	NPO	SM0603	Various	
2	2	C4, C2	10µF	10	25V	X5R	SM0805	Various	
3	6	J1, J2, J3, J4, J5, J6	Header 1x2			Header		MOLEX	22-03-2021
4	1	JP1	Header 1x3			Header		MOLEX	22-03-2031
5	2	R1, R2	2.61k	1	100mW	THK FILM	SM0603	Various	
6	1	R3	1.87k	1	100mW	THK FILM	SM0603	Various	
7	1	R4	1k	1	100mW	THK FILM	SM0603	Various	
8	1	R5	649	1	100mW	THK FILM	SM0603	Various	
9	1	R6	464	1	100mW	THK FILM	SM0603	Various	
10	1	R7	287	1	100mW	THK FILM	SM0603	Various	
11	0	TP1, TP2, TP3	Do Not Populated			Test point			
12	1	U1	ISL80510				8 Ld 3x3 DFN	INTERSIL	ISL80510IRAJZ
13	4	CON1, CON2, CON3, CON4				Terminal	Turret	Keystone	1514-2

Board Layout - 2 Layers

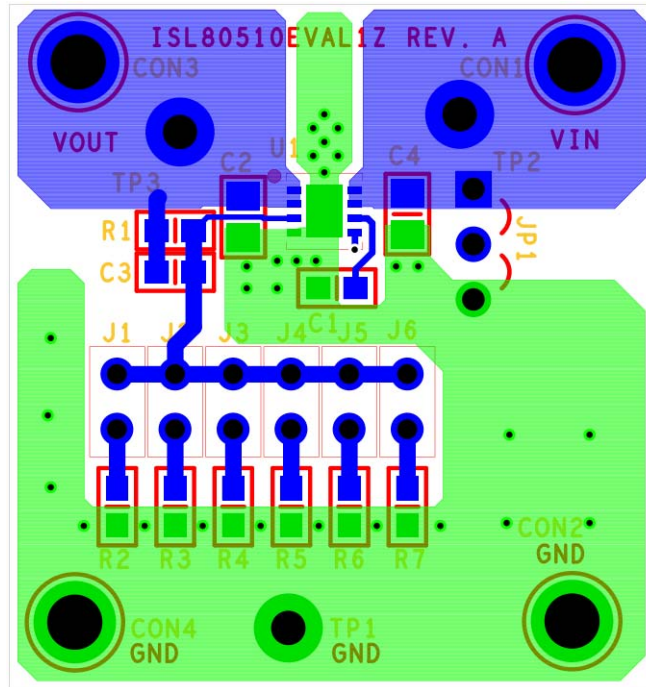

FIGURE 5. TOP LAYER

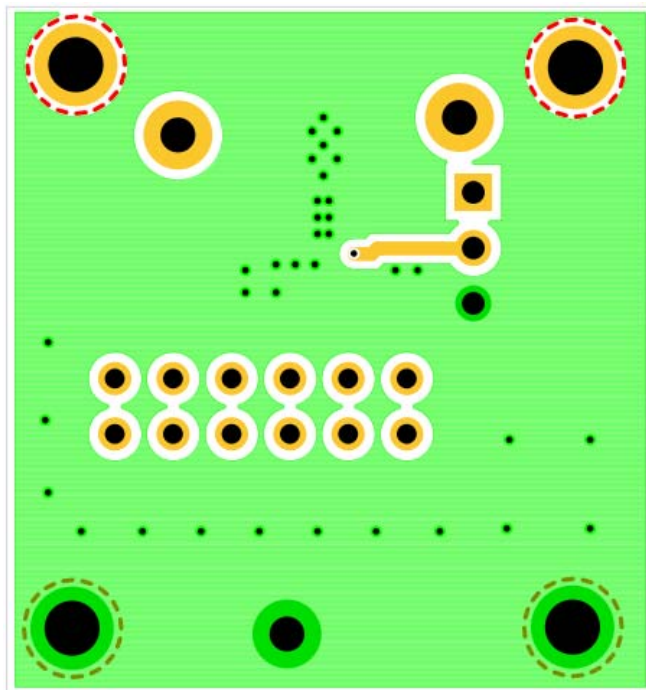

FIGURE 6. PCB - BOTTOM LAYER (VIEWED FROM TOP)

Typical Performance Curves

Unless otherwise noted: $V_{IN} = 2.2V$, $V_{OUT} = 1.8V$, $T_J = +25^\circ C$, $I_L = 0A$.

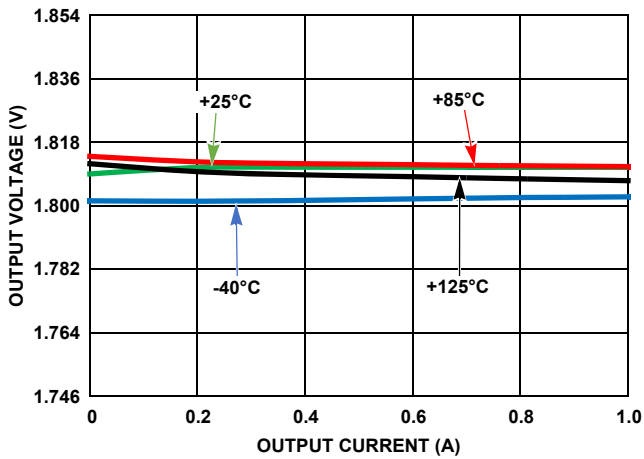

FIGURE 7. LOAD REGULATION

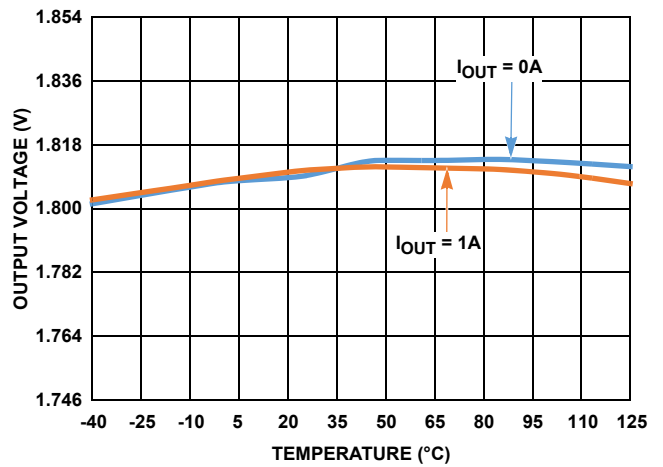

FIGURE 8. OUTPUT VOLTAGE vs TEMPERATURE

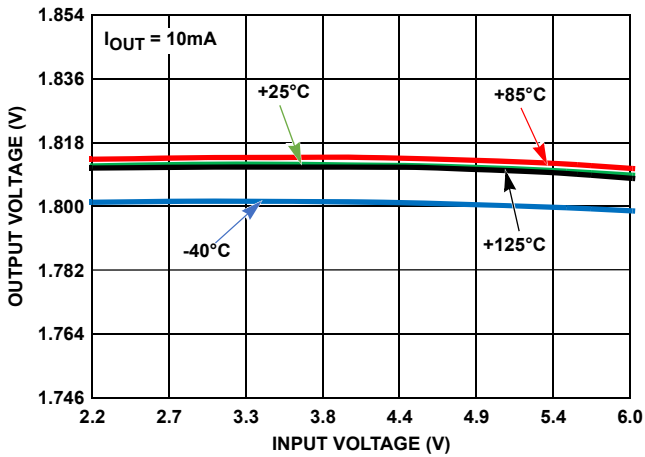

FIGURE 9. LINE REGULATION

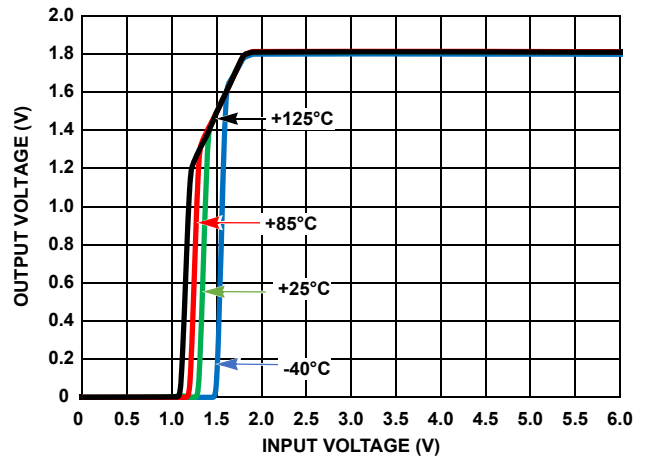

FIGURE 10. OUTPUT VOLTAGE vs INPUT VOLTAGE

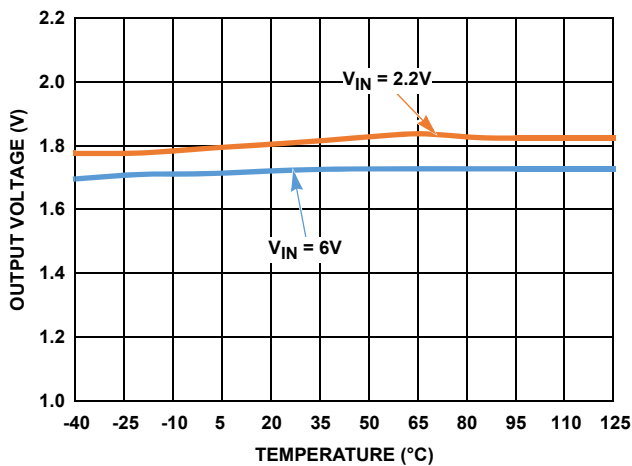

FIGURE 11. CURRENT LIMIT vs TEMPERATURE

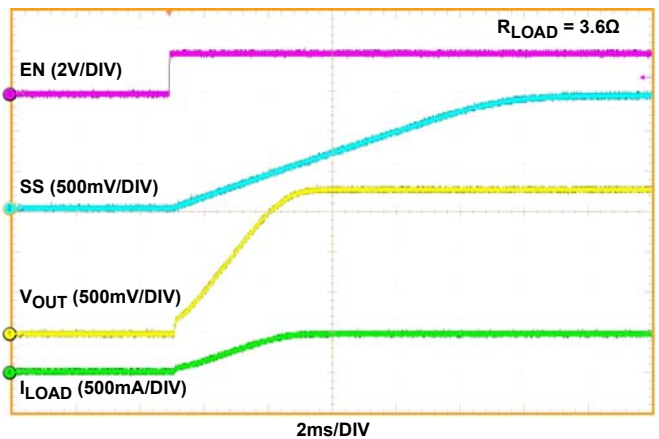

FIGURE 12. ENABLE START-UP ($C_{SS} = 10nF$)

Typical Performance Curves

Unless otherwise noted: $V_{IN} = 2.2V$, $V_{OUT} = 1.8V$, $T_J = +25^\circ C$, $I_L = 0A$.

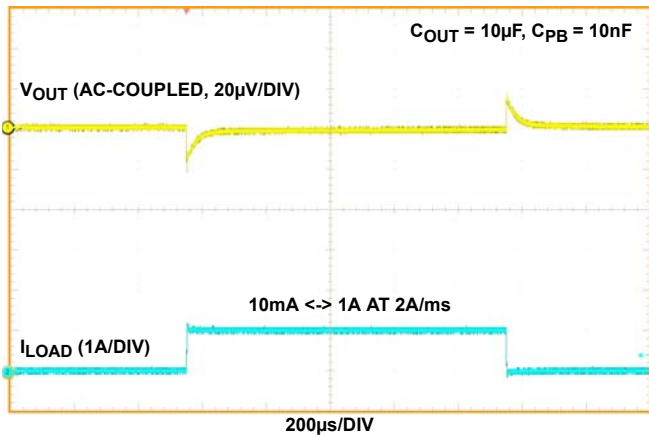

FIGURE 13. LOAD TRANSIENT RESPONSE

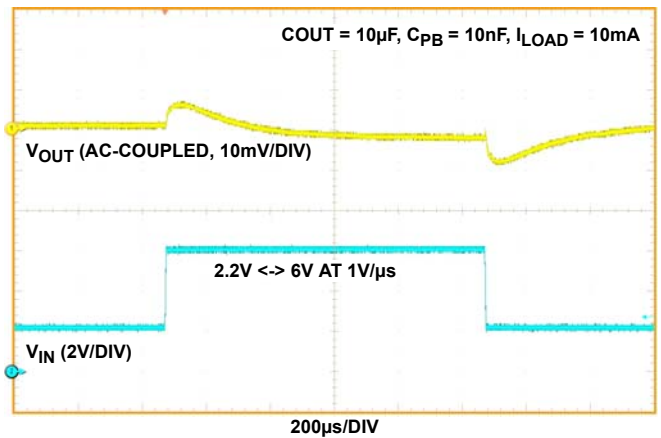

FIGURE 14. LINE TRANSIENT RESPONSE

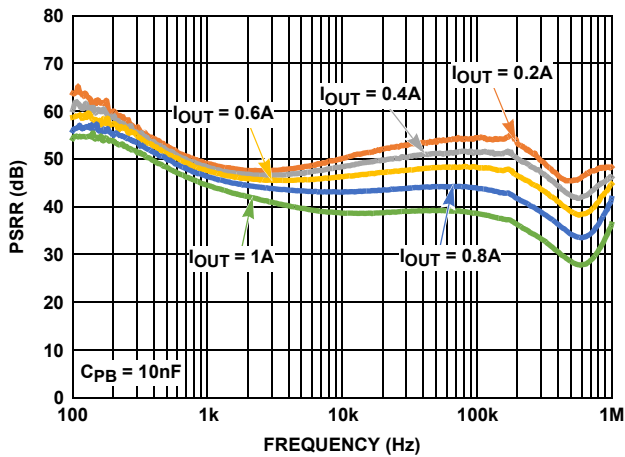

FIGURE 15. PSRR vs FREQUENCY

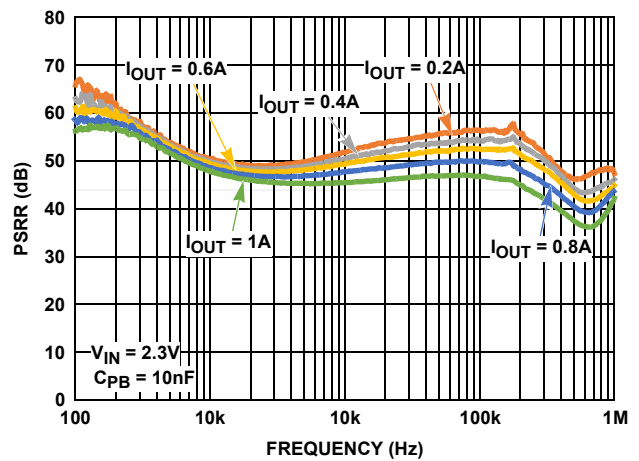

FIGURE 16. PSRR vs FREQUENCY

Intersil Corporation reserves the right to make changes in circuit design, software and/or specifications at any time without notice. Accordingly, the reader is cautioned to verify that the document is current before proceeding.

For information regarding Intersil Corporation and its products, see www.intersil.com