



Chipsmall Limited consists of a professional team with an average of over 10 year of expertise in the distribution of electronic components. Based in Hongkong, we have already established firm and mutual-benefit business relationships with customers from,Europe,America and south Asia,supplying obsolete and hard-to-find components to meet their specific needs.

With the principle of “Quality Parts,Customers Priority,Honest Operation,and Considerate Service”,our business mainly focus on the distribution of electronic components. Line cards we deal with include Microchip,ALPS,ROHM,Xilinx,Pulse,ON,Everlight and Freescale. Main products comprise IC,Modules,Potentiometer,IC Socket,Relay,Connector.Our parts cover such applications as commercial,industrial, and automotives areas.

We are looking forward to setting up business relationship with you and hope to provide you with the best service and solution. Let us make a better world for our industry!



Contact us

Tel: +86-755-8981 8866 Fax: +86-755-8427 6832

Email & Skype: info@chipsmall.com Web: www.chipsmall.com

Address: A1208, Overseas Decoration Building, #122 Zhenhua RD., Futian, Shenzhen, China



ISL97682 LED Driver Evaluation Board User Manual

Introduction

The ISL97682IRTZEVALZ Evaluation Board provides a complete testing platform for the ISL97682, a two channel LED driver. Please refer to the product datasheet (ISL97682, [FN7689](#)) for detailed information including pinout, pin function description, electrical specifications, applications related information, etc.

Instructions

Please follow the steps described below to start your evaluation.

1. For both switch #1 and #2 (SW1 and SW2 shown on the board), set them to position 3 (left side).
2. For enable control jumper JP1, put the shunt to the “ON” position (right side) to connect EN pin to VIN. When the shunt is set to the “OFF” position, it will disable the chip by pulling the EN pin to ground.
3. Connect JP14 so the VIN pin is connected to PVIN.
4. For JP20, connect the shunt to the upper position.
5. Connect WR and JP2-JP6.
6. Apply 1.5V~5.5V PWM signal between PWMI pin and AGND.
7. Apply 4V~26.5V between PVIN and PGND and the LEDs should be lit, and you can start the evaluation.

NOTE: In step #1 above, the SW1, SW2 position can be adjusted to different positions for different configurations, see Table 1 for details.

TABLE 1.

SW1 POSITION	SW2 POSITION	DESCRIPTION
1	1	LX switching frequency = 600kHz, PFM CH1 and CH3
3	3	LX switching frequency = 1MHz, PFM CH1 and CH3
3	1	LX switching frequency = 600kHz, No PFM CH1 and CH3
1	3	LX switching frequency = 1MHz, No PFM CH1 and CH3

- The LED maximum DC current adjustment.
For each channel, the maximum DC current is set by resistance connected to RSET pin. The current for each channel can be calculated as shown in Equation 1:

$$I_{LED}(mA) = \frac{402}{RSET(k\Omega)} \quad (EQ. 1)$$

On the board, a potentiometer R5 and a few other resistors are provided for easily adjust the LED maximum DC current.

Please refer to the “ISL97682IRTZEVALZ Evaluation Board Schematic” on page 2 for more details.

- LED dimming frequency and duty cycle.
 - As mentioned in step #4 above, when the shunt on JP20 is connected to the upper position, FPWM/DPWM pin is connected to VDC, the device enters direct PWM mode, which means both the LED dimming frequency and the duty cycle are synchronized with the external PWM signal applied on the PWMI pin.
 - When the shunt on JP20 is connected to the lower position, the FPWM/DPWM pin is connected to a resistor. Under such conditions, the LED dimming frequency of the chip is programmed by the resistance connected on the FPWM/DPWM pin as per Equation 2:

$$FPWM(Hz) = 12.4 \cdot \frac{10^7}{R_{FPWM}(\Omega)} \quad (EQ. 2)$$

The duty cycle is still modulated by the external PWM signal applied on PWMI pin. On board, potentiometer R11 and a few other resistors are provided for easily adjusting the LED dimming frequency under such a configuration.

ISL97682IRTZEVALZ Evaluation Board Schematic

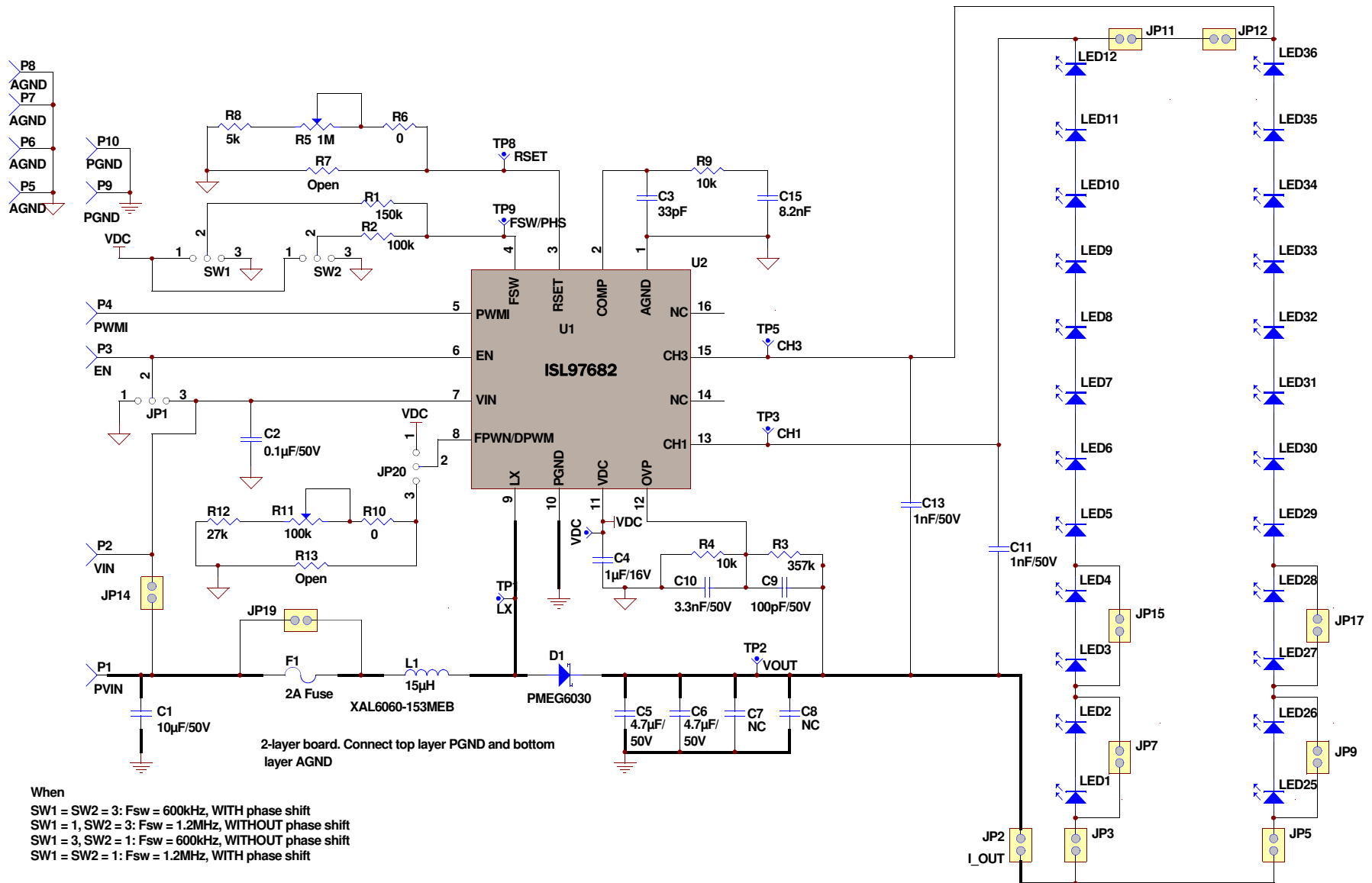

When

- SW1 = SW2 = 3: Fsw = 600kHz, WITH phase shift
- SW1 = 1, SW2 = 3: Fsw = 1.2MHz, WITHOUT phase shift
- SW1 = 3, SW2 = 1: Fsw = 600kHz, WITHOUT phase shift
- SW1 = SW2 = 1: Fsw = 1.2MHz, WITH phase shift

EN can be connected in the following ways to enable/disable the device:

- (1) Connected it to VIN directly on JP1 to enable
- (2) Connected it to GND directly on JP1 to disable
- (3) Directly apply external voltage on P3(EN) to enable/disable the device without putting shunt on JP1.

JP2: For measuring total output current

JP3-JP6: For measuring current on CH1-CH4 respectively

JP7-JP10, JP13-JP16: For easy configuration of 8x LED or 10x LED per string

PCB Layout

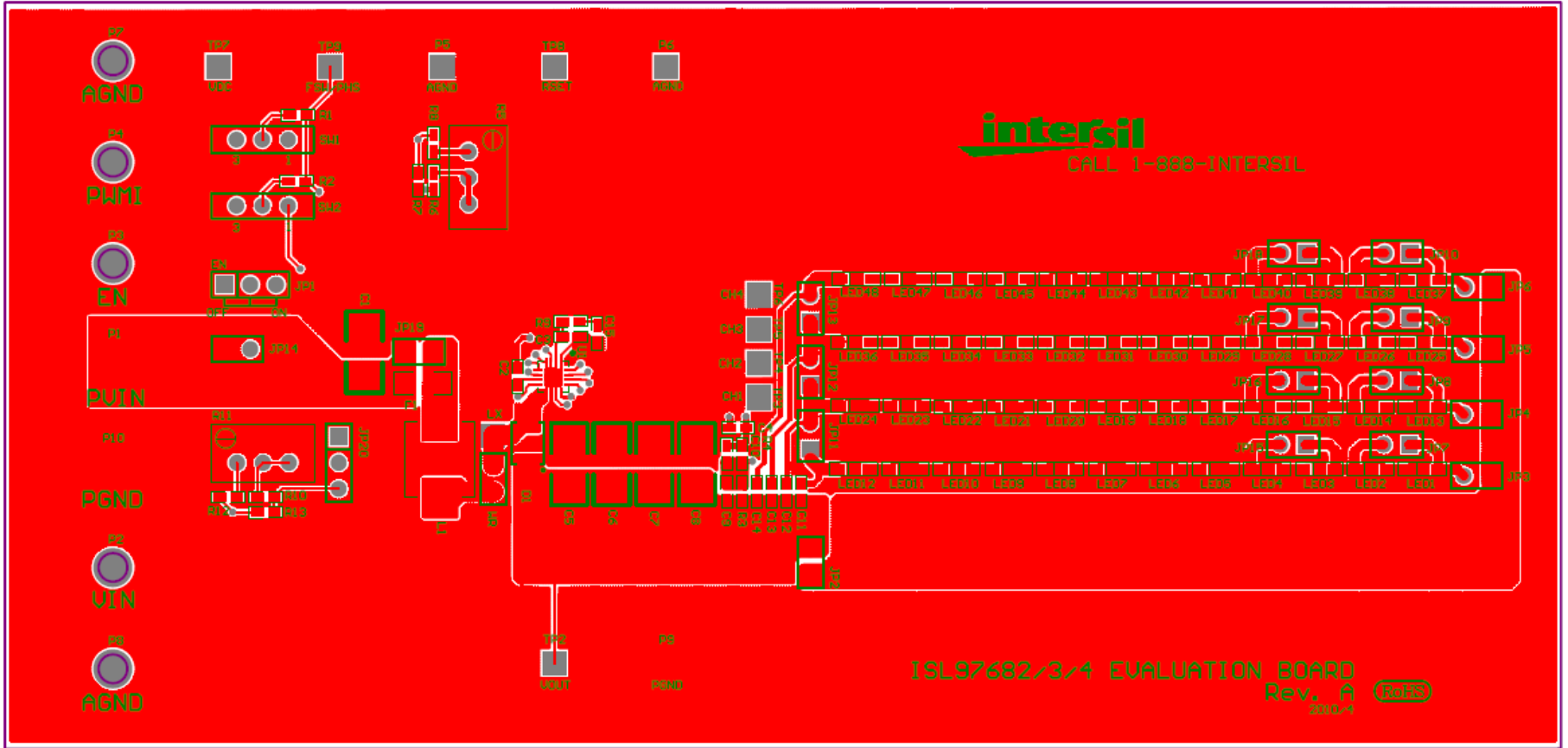

FIGURE 1. TOP SILKSCREEN LAYER + TOP LAYER

PCB Layout (Continued)

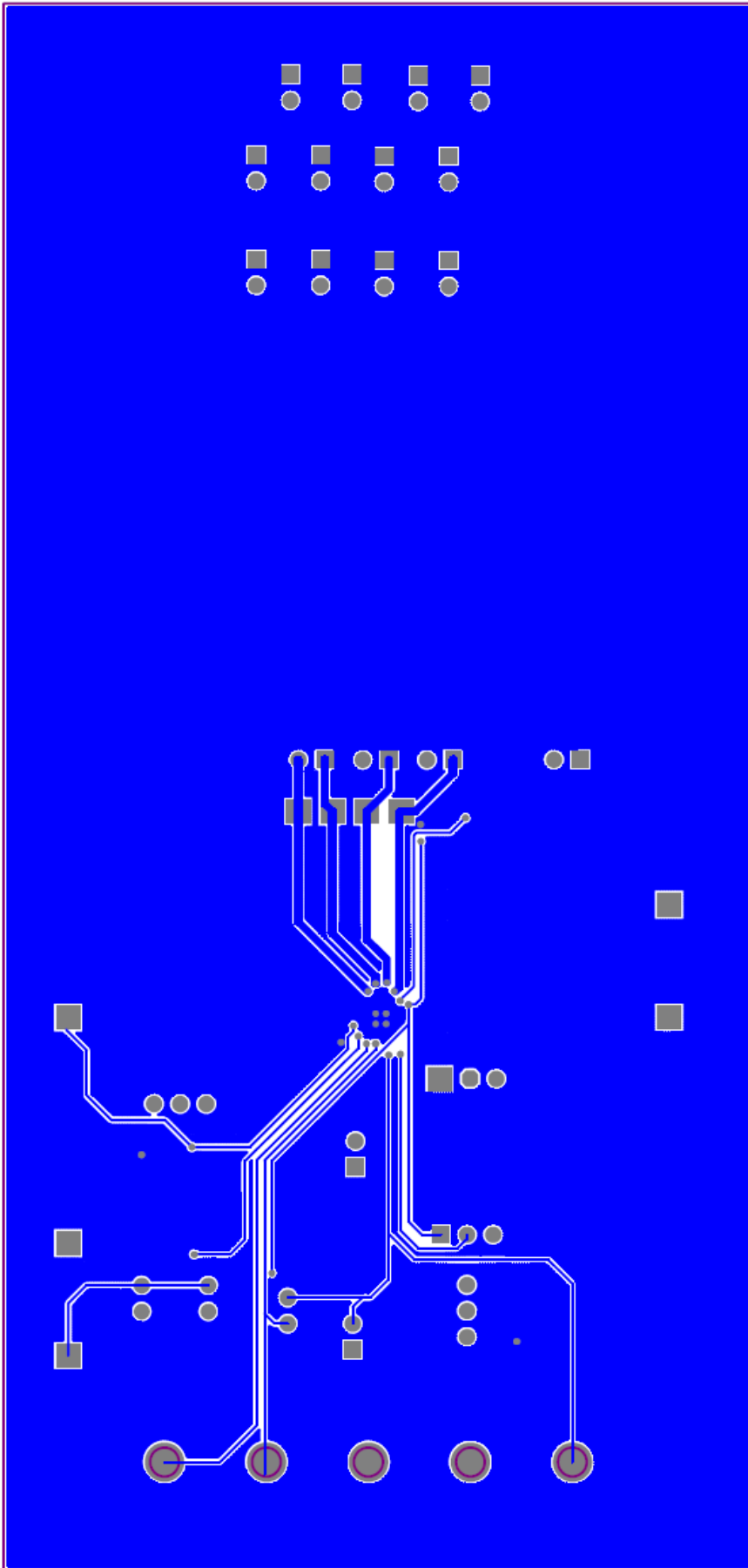

FIGURE 2. BOTTOM LAYER

Application Note 1662

Bill of Materials (BOM)

DESIGNATOR	PART TYPE	FOOTPRINT	PART MANUFACTURER/NUMBER
R1	150k	603	1% SMD Resistor General purpose
R2	100k	603	
R3	357k	603	
R4	10k	603	
R5	1M	VRES	
R6	open		
R7	38.3k	603	
R8	5k	603	
R9	10k	603	
R10	0	603	
R11	100k	VRES	
R12	0	603	
R13	Open	603	
L1	15 μ H		CoilCraft (XAL6060-153MEB)
D1	PMEG6030		
C1	10 μ F/35V	1210	General purpose Ceramic X5R/X7R capacitors
C2	0.1 μ F/50V	603	
C3	33pF	603	
C4	1 μ F/16V	603	
C5	4.7 μ F/50V	1210	Murata, GRM32ER71H475KA88L
C6	4.7 μ F/50V	1210	
C7	Place Holder	1210	Not Populated
C8	Place Holder	1210	
C9	100pF/50V	603	General purpose Ceramic X5R/X7R capacitors
C10	3.3nF/50V	603	
C11	1nF/50V	603	
C12	Place Holder	603	
C13	1nF/50V	603	
C14	Place Holder	603	
C15	8.2nF	603	
F1	2A Fuse	1206	Bel Fuse Inc, C1Q 2
U1		QFN16 3MM	Intersil, ISL97682/3/4
JP2-JP19	JUMPER-2PIN	JUMPER-2PIN	FCI 68000-236HLF-1x2
WR	JUMPER-2PIN	JUMPER-2PIN	
JP1	JUMPER-3PIN	JUMPER-3PIN	FCI 68000-236HLF-1x3
JP20	JUMPER-3PIN	JUMPER-3PIN	
LED1-12 LED25-36	LED-SMT	LW_Y87C	

Application Note 1662

Bill of Materials (BOM) (Continued)

DESIGNATOR	PART TYPE	FOOTPRINT	PART MANUFACTURER/NUMBER
TP1	LX	TEST POINT	Keystone Electronics 5010
TP2	VOUT	TEST POINT	
TP3	CH1	TEST POINT	
TP4	CH2	TEST POINT	
TP5	CH3	TEST POINT	
TP6	CH4	TEST POINT	
TP7	VDC	TEST POINT	
TP8	RSET	TEST POINT	
TP9	FSW/PHS	TEST POINT	
P5	AGND	TEST POINT	Keystone Electronics 5011
P6	AGND	TEST POINT	
P9	PGND	TEST POINT	
P1	PVIN	POWERPOST	Mill Max 3156-1-00-00-00-00-08-0
P2	VIN	POWERPOST	
P3	EN	POWERPOST	
P4	PWMI	POWERPOST	
P7	AGND	POWERPOST	
P8	AGND	POWERPOST	
P10	PGND	POWERPOST	
SW2	SPDT	SWITCH-SLIDE-SPDT	EAO 09.03201.02
SW1	SPDT	SWITCH-SLIDE-SPDT	

Intersil Corporation reserves the right to make changes in circuit design, software and/or specifications at any time without notice. Accordingly, the reader is cautioned to verify that the Application Note or Technical Brief is current before proceeding.

For information regarding Intersil Corporation and its products, see www.intersil.com