



Chipsmall Limited consists of a professional team with an average of over 10 year of expertise in the distribution of electronic components. Based in Hongkong, we have already established firm and mutual-benefit business relationships with customers from,Europe,America and south Asia,supplying obsolete and hard-to-find components to meet their specific needs.

With the principle of “Quality Parts,Customers Priority,Honest Operation,and Considerate Service”,our business mainly focus on the distribution of electronic components. Line cards we deal with include Microchip,ALPS,ROHM,Xilinx,Pulse,ON,Everlight and Freescale. Main products comprise IC,Modules,Potentiometer,IC Socket,Relay,Connector.Our parts cover such applications as commercial,industrial, and automotives areas.

We are looking forward to setting up business relationship with you and hope to provide you with the best service and solution. Let us make a better world for our industry!



Contact us

Tel: +86-755-8981 8866 Fax: +86-755-8427 6832

Email & Skype: info@chipsmall.com Web: www.chipsmall.com

Address: A1208, Overseas Decoration Building, #122 Zhenhua RD., Futian, Shenzhen, China



Dual 14-Bit, 250MSPS/200MSPS/130MSPS ADC

ISLA224P

The ISLA224P is a family of dual-channel 14-Bit analog-to-digital converters. Designed with Intersil's proprietary FemtoCharge™ technology on a standard CMOS process, the family supports sampling rates of up to 250MSPS. The ISLA224P is part of a pin-compatible portfolio of 12-bit and 14-bit dual-channel A/Ds with maximum sample rates ranging from 130MSPS to 250MSPS.

A serial peripheral interface (SPI) port allows for extensive configurability, as well as fine control of various parameters such as gain and offset.

Digital output data is presented in selectable LVDS or CMOS formats. The ISLA224P is available in a 72-contact QFN package with an exposed paddle. Operating from a 1.8V supply, performance is specified over the full industrial temperature range (-40 °C to +85 °C).

Key Specifications

- SNR @ 250/200/130MSPS
72.7/73.9/74.7dBFS $f_{IN} = 30\text{MHz}$
70.2/70.7/70.2dBFS $f_{IN} = 363\text{MHz}$
- SFDR @ 250/200/130MSPS
84/86/86dBc $f_{IN} = 30\text{MHz}$
73/75/79dBc $f_{IN} = 363\text{MHz}$
- Total Power Consumption = 837mW @ 250MSPS

Features

- Single supply 1.8V operation
- Clock duty cycle stabilizer
- 75fs clock jitter
- 700MHz bandwidth
- Programmable built-in test patterns
- Multi-ADC support
 - SPI programmable fine gain and offset control
 - Support for multiple ADC synchronization
 - Optimized output timing
- Nap and sleep modes
 - 200µs sleep wake-up time
- Data output clock
- DDR LVDS-compatible or LVCMOS outputs
- Selectable clock divider

Applications

- Radar array processing
- Software defined radios
- Broadband communications
- High-performance data acquisition
- Communications test equipment

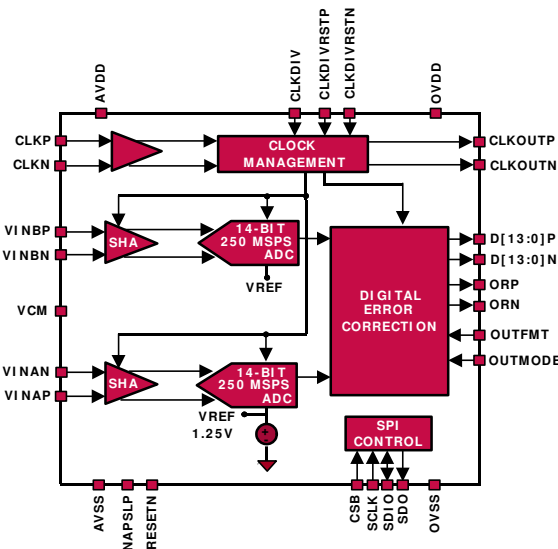

Pin-Compatible Family

MODEL	RESOLUTION	SPEED (MSPS)
ISLA224P25	14	250
ISLA224P20	14	200
ISLA224P13	14	130
ISLA222P25	12	250
ISLA222P20	12	200
ISLA222P13	12	130

ISLA224P

Pin Configuration - LVDS Mode

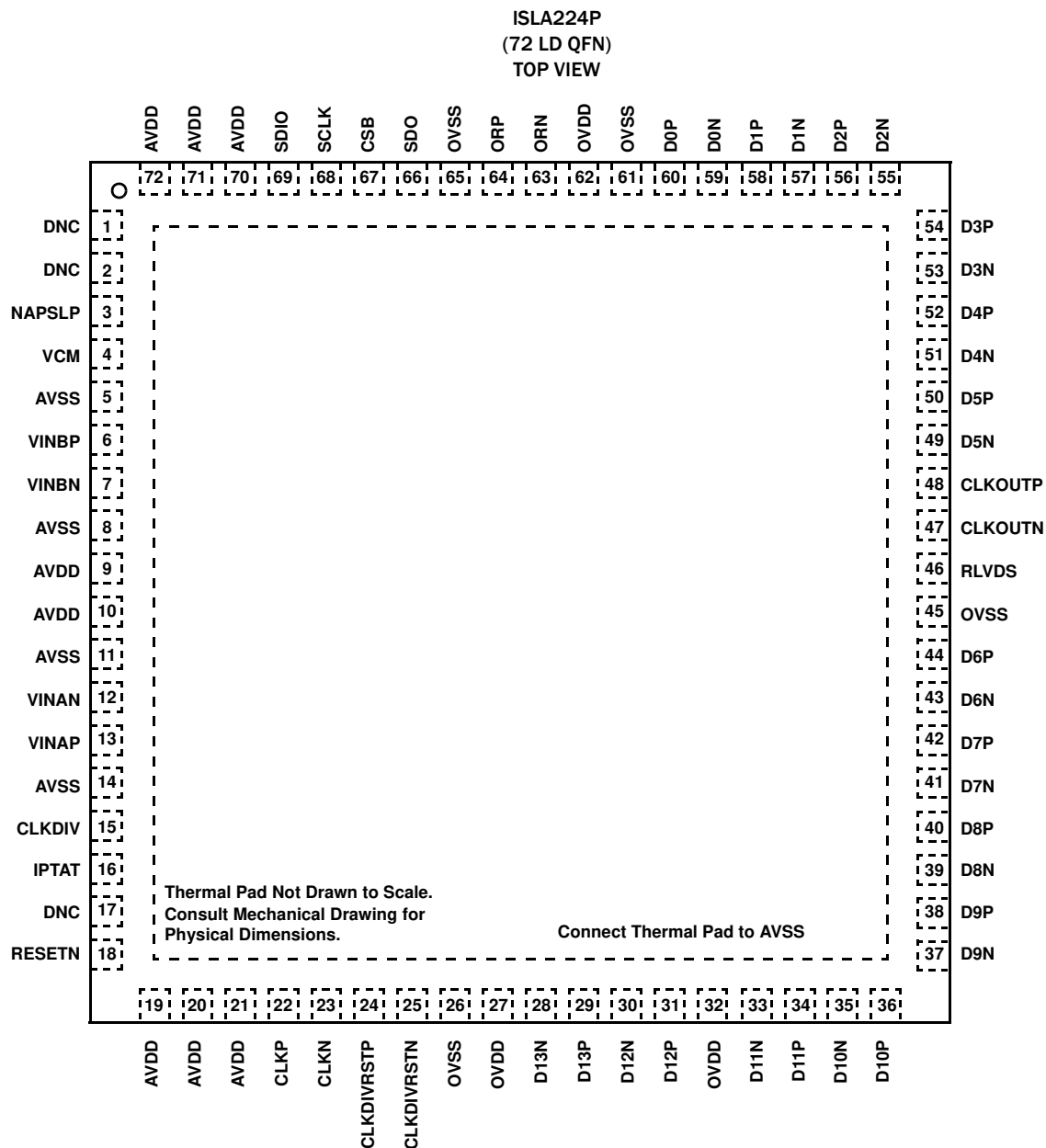

Pin Descriptions - 72 Ld QFN, LVDS Mode

PIN NUMBER	LVDS PIN NAME	LVDS PIN FUNCTION
1, 2, 17	DNC	Do Not Connect
9, 10, 19, 20, 21, 70, 71, 72	AVDD	1.8V Analog Supply
5, 8, 11, 14	AVSS	Analog Ground
27, 32, 62	OVDD	1.8V Output Supply
26, 45, 61, 65	OVSS	Output Ground
3	NAPSLP	Tri-Level Power Control (Nap, Sleep modes)
4	VCM	Common Mode Output
6, 7	VINBP, VINBN	Channel B Analog Input Positive, Negative

ISLA224P

Pin Descriptions - 72 Ld QFN, LVDS Mode (Continued)

PIN NUMBER	LVDS PIN NAME	LVDS PIN FUNCTION
12, 13	VINAN, VINAP	Channel A Analog Input Negative, Positive
15	CLKDIV	Tri-Level Clock Divider Control
16	IPTAT	Temperature Monitor (Output current proportional to absolute temperature)
18	RESETN	Power On Reset (Active Low)
22, 23	CLKP, CLKN	Clock Input True, Complement
24, 25	CLKDIVRSTP, CLKDIVRSTN	Synchronous Clock Divider Reset True, Complement
28, 29	D13N, D13P	LVDS Bit 13 (MSB) Output Complement, True
30, 31	D12N, D12P	LVDS Bit 12 Output Complement, True
33, 34	D11N, D11P	LVDS Bit 11 Output Complement, True
35, 36	D10N, D10P	LVDS Bit 10 Output Complement, True
37, 38	D9N, D9P	LVDS Bit 9 Output Complement, True
39, 40	D8N, D8P	LVDS Bit 8 Output Complement, True
41, 42	D7N, D7P	LVDS Bit 7 Output Complement, True
43, 44	D6N, D6P	LVDS Bit 6 Output Complement, True
46	RLVDS	LVDS Bias Resistor (connect to OVSS with 1%10k Ω)
47, 48	CLKOUTN, CLKOUTP	LVDS Clock Output Complement, True
49, 50	D5N, D5P	LVDS Bit 5 Output Complement, True
51, 52	D4N, D4P	LVDS Bit 4 Output Complement, True
53, 54	D3N, D3P	LVDS Bit 3 Output Complement, True
55, 56	D2N, D2P	LVDS Bit 2 Output Complement, True
57, 58	D1N, D1P	LVDS Bit 1 Output Complement, True
59, 60	D0N, D0P	LVDS Bit 0 (LSB) Output Complement, True
63, 64	ORN, ORP	LVDS Over Range Complement, True
66	SDO	SPI Serial Data Output
67	CSB	SPI Chip Select (active low)
68	SCLK	SPI Clock
69	SDIO	SPI Serial Data Input/Output
Exposed Paddle	AVSS	Analog Ground

ISLA224P

Pin Configuration - CMOS Mode

ISLA224P
(72 LD QFN)
TOP VIEW

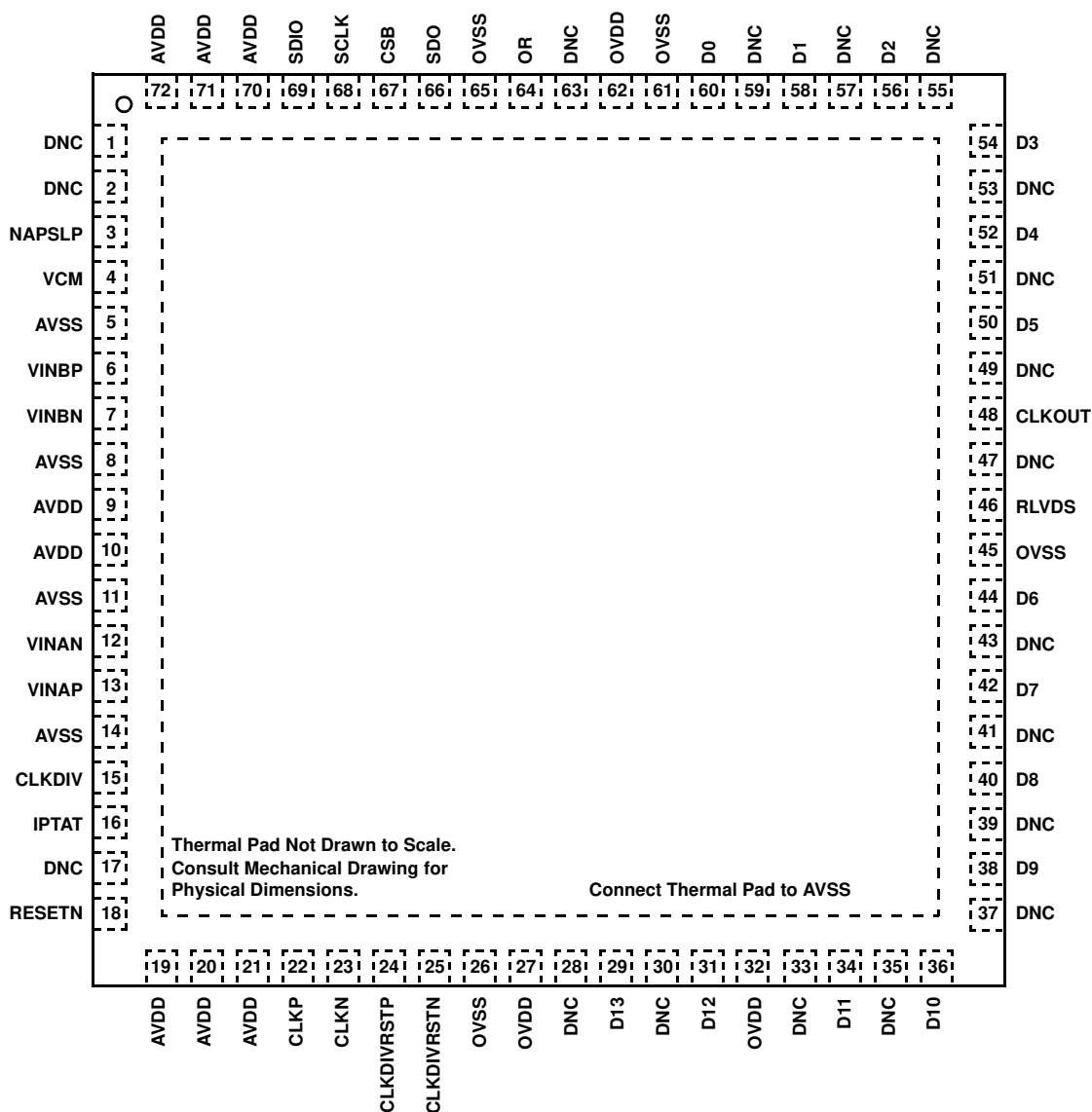

Pin Descriptions - 72 Ld QFN, CMOS Mode

PIN NUMBER	CMOS PIN NAME	CMOS PIN FUNCTION
1, 2, 17, 28, 30, 33, 35, 37, 39, 41, 43, 47, 49, 51, 53, 55, 57, 59, 63	DNC	Do Not Connect
9, 10, 19, 20, 21, 70, 71, 72	AVDD	1.8V Analog Supply
5, 8, 11, 14	AVSS	Analog Ground
27, 32, 62	OVDD	1.8V Output Supply
26, 45, 61, 65	OVSS	Output Ground
3	NAPSLP	Tri-Level Power Control (Nap, Sleep modes)
4	VCM	Common Mode Output

ISLA224P

Pin Descriptions - 72 Ld QFN, CMOS Mode (Continued)

PIN NUMBER	CMOS PIN NAME	CMOS PIN FUNCTION
6, 7	VINBP, VINBN	Channel B Analog Input Positive, Negative
12, 13	VINAN, VINAP	Channel A Analog Input Negative, Positive
15	CLKDIV	Tri-Level Clock Divider Control
16	IPTAT	Temperature Monitor (Output current proportional to absolute temperature)
18	RESETN	Power On Reset (Active Low)
22, 23	CLKP, CLKN	Clock Input True, Complement
24, 25	CLKDIVRSTP, CLKDIVRSTN	Synchronous Clock Divider Reset True, Complement
29	D13	CMOS Bit 13 (MSB) Output
31	D12	CMOS Bit 12 Output
34	D11	CMOS Bit 11 Output
36	D10	CMOS Bit 10 Output
38	D9	CMOS Bit 9 Output
40	D8	CMOS Bit 8 Output
42	D7	CMOS Bit 7 Output
44	D6	CMOS Bit 6 Output
46	RLVDS	LVDS Bias Resistor (connect to OVSS with 1%10k Ω)
48	CLKOUT	CMOS Clock Output
50	D5	CMOS Bit 5 Output
52	D4	CMOS Bit 4 Output
54	D3	CMOS Bit 3 Output
56	D2	CMOS Bit 2 Output
58	D1	CMOS Bit 1 Output
60	D0	CMOS Bit 0 (LSB) Output
64	OR	CMOS Over Range
66	SDO	SPI Serial Data Output
67	CSB	SPI Chip Select (active low)
68	SCLK	SPI Clock
69	SDIO	SPI Serial Data Input/Output
Exposed Paddle	AVSS	Analog Ground

ISLA224P

Ordering Information

PART NUMBER (Notes 1, 2)	PART MARKING	TEMP. RANGE (°C)	PACKAGE (Pb-free)	PKG. DWG. #
ISLA224P13IRZ	ISLA224P13 IRZ	-40°C to +85°C	72 Ld QFN	L72.10x10E
ISLA224P20IRZ	ISLA224P20 IRZ	-40°C to +85°C	72 Ld QFN	L72.10x10E
ISLA224P25IRZ	ISLA224P25 IRZ	-40°C to +85°C	72 Ld QFN	L72.10x10E
ISLA224IR72EV1Z	Evaluation Board			

NOTES:

1. These Intersil Pb-free plastic packaged products employ special Pb-free material sets; molding compounds/die attach materials and NiPdAu plate-e4 termination finish, which is RoHS compliant and compatible with both SnPb and Pb-free soldering operations. Intersil Pb-free products are MSL classified at Pb-free peak reflow temperatures that meet or exceed the Pb-free requirements of IPC/JEDEC J STD-020.
2. For Moisture Sensitivity Level (MSL), please see respective device information page for [ISLA224P](#). For more information on MSL please see techbrief [TB363](#).

Table of Contents

Absolute Maximum Ratings	8
Thermal Information	8
Electrical Specifications	8
Digital Specifications	10
Timing Diagrams	11
Switching Specifications	12
Typical Performance Curves	13
Theory of Operation	16
Functional Description	16
Power-On Calibration	16
User Initiated Reset	17
Temperature Calibration	18
Analog Input	19
Clock Input	19
Jitter	20
Voltage Reference	20
Digital Outputs	20
Power Dissipation	20
Nap/Sleep	20
Data Format	21
Clock Divider Synchronous Reset	21
Serial Peripheral Interface	24
SPI Physical Interface	24
SPI Configuration	25
Device Information	25
Device Configuration/Control	25
Global Device Configuration/Control	26
Digital Temperature Sensor	28
SPI Memory Map	29
Equivalent Circuits	31
A/D Evaluation Platform	32
Layout Considerations	32
Split Ground and Power Planes	32
Clock Input Considerations	32
Exposed Paddle	32
Bypass and Filtering	32
LVDS Outputs	32
LVCMOS Outputs	32
Unused Inputs	32
Definitions	32
Revision History	33
About Intersil	33
Package Outline Drawing	34

ISLA224P

Absolute Maximum Ratings

AVDD to AVSS	-0.4V to 2.1V
OVDD to OVSS	-0.4V to 2.1V
AVSS to OVSS	-0.3V to 0.3V
Analog Inputs to AVSS	-0.4V to AVDD + 0.3V
Clock Inputs to AVSS	-0.4V to AVDD + 0.3V
Logic Input to AVSS	-0.4V to OVDD + 0.3V
Logic Inputs to OVSS	-0.4V to OVDD + 0.3V
Latchup (Tested per JESD-78C; Class 2, Level A)	100mA

Thermal Information

Thermal Resistance (Typical)	θ_{JA} (°C/W)	θ_{JC} (°C/W)
72 Ld QFN (Notes 3, 4)	23	0.9
Operating Temperature	-40°C to +85°C	
Storage Temperature	-65°C to +150°C	
Junction Temperature	+150°C	
Pb-Free Reflow Profile	see link below	
	http://www.intersil.com/pbfree/Pb-FreeReflow.asp	

CAUTION: Do not operate at or near the maximum ratings listed for extended periods of time. Exposure to such conditions may adversely impact product reliability and result in failures not covered by warranty.

NOTES:

- θ_{JA} is measured in free air with the component mounted on a high effective thermal conductivity test board with “direct attach” features. See Tech Brief [TB379](#).
- For θ_{JC} , the “case temp” location is the center of the exposed metal pad on the package underside.

Electrical Specifications All specifications apply under the following conditions unless otherwise noted: AVDD = 1.8V, OVDD = 1.8V, T_A = -40°C to +85°C (typical specifications at +25°C), A_{IN} = -1dBFS, f_{SAMPLE} = Maximum Conversion Rate (per speed grade). **Boldface limits apply over the operating temperature range, -40°C to +85°C.**

PARAMETER	SYMBOL	CONDITIONS	ISLA224P25			ISLA224P20			ISLA224P13			UNITS
			MIN (Note 5)	TYP	MAX (Note 5)	MIN (Note 5)	TYP	MAX (Note 5)	MIN (Note 5)	TYP	MAX (Note 5)	
DC SPECIFICATIONS (Note 6)												
Analog Input												
Full-Scale Analog Input Range	V_{FS}	Differential	1.95	2.0	2.2	1.95	2.0	2.2	1.95	2.0	2.2	V_{P-P}
Input Resistance	R_{IN}	Differential		600			600			600		Ω
Input Capacitance	C_{IN}	Differential		4.5			4.5			4.5		pF
Full Scale Range Temp. Drift	A_{VTC}	Full Temp		108			82			75		ppm/°C
Input Offset Voltage	V_{OS}		-7.0	-1.7	7.0	-5.0	-1.7	5.0	-5.0	-1.7	5.0	mV
Common-Mode Output Voltage	V_{CM}			0.94			0.94			0.94		V
Common-Mode Input Current (per pin)	I_{CM}			2.6			2.6			2.6		$\mu A/MSPS$
Clock Inputs												
Inputs Common Mode Voltage				0.9			0.9			0.9		V
CLKP,CLKN Input Swing				1.8			1.8			1.8		V
Power Requirements												
1.8V Analog Supply Voltage	AVDD		1.7	1.8	1.9	1.7	1.8	1.9	1.7	1.8	1.9	V
1.8V Digital Supply Voltage	OVDD		1.7	1.8	1.9	1.7	1.8	1.9	1.7	1.8	1.9	V
1.8V Analog Supply Current	I_{AVDD}			375	389		344	376		293	312	mA
1.8V Digital Supply Current (Note 6)	I_{OVDD}	3mA LVDS		90	100		85	93		75	83	mA
Power Supply Rejection Ratio	PSRR	30MHz, 50mVP-P signal on AVDD		-65			-65			-65		dB

ISLA224P

Electrical Specifications All specifications apply under the following conditions unless otherwise noted: AVDD = 1.8V, OVDD = 1.8V, T_A = -40 °C to +85 °C (typical specifications at +25 °C), A_{IN} = -1dBFS, f_{SAMPLE} = Maximum Conversion Rate (per speed grade). **Boldface limits apply over the operating temperature range, -40 °C to +85 °C. (Continued)**

PARAMETER	SYMBOL	CONDITIONS	ISLA224P25			ISLA224P20			ISLA224P13			UNITS
			MIN (Note 5)	TYP	MAX (Note 5)	MIN (Note 5)	TYP	MAX (Note 5)	MIN (Note 5)	TYP	MAX (Note 5)	
Total Power Dissipation												
Normal Mode	P _D	2mA LVDS		810			750			640		mW
		3mA LVDS		837	880		772	844		662	711	mW
		CMOS		780			705			590		mW
Nap Mode	P _D		87	96		83	93		77	85	mW	
Sleep Mode	P _D	CSB at logic high		6	11		6	11		6	10	mW
Nap/Sleep Mode Wakeup Time		Sample Clock Running		200			400			630		μs
AC SPECIFICATIONS												
Differential Nonlinearity	DNL	f _{IN} = 105MHz No Missing Codes	-0.99	±0.5	2.0	-0.99	±0.4	0.99	-0.99	±0.4	0.99	LSB
Integral Nonlinearity	INL	f _{IN} = 105MHz		±4.0			±3.0			±3.0		LSB
Minimum Conversion Rate (Note 7)	f _S MIN				40				40			MSPS
Maximum Conversion Rate	f _S MAX		250			200			130			MSPS
Signal-to-Noise Ratio (Note 8)	SNR	f _{IN} = 30MHz		72.7			73.9			74.7		dBFS
		f _{IN} = 105MHz	70.6	72.5		72.0	73.6		72.7	74.3		dBFS
		f _{IN} = 190MHz		71.8			72.8			72.9		dBFS
		f _{IN} = 363MHz		70.2			70.7			70.2		dBFS
		f _{IN} = 461MHz		69.3			69.3			68.8		dBFS
		f _{IN} = 605MHz		67.9			68.0			68.0		dBFS
Signal-to-Noise and Distortion (Note 8)	SINAD	f _{IN} = 30MHz		72.1			73.5			74.2		dBFS
		f _{IN} = 105MHz	68.8	71.0		69.8	72.7		70.0	72.8		dBFS
		f _{IN} = 190MHz		70.0			71.5			71.4		dBFS
		f _{IN} = 363MHz		68.0			69.1			69.5		dBFS
		f _{IN} = 461MHz		66.0			66.3			65.7		dBFS
		f _{IN} = 605MHz		63.8			62.1			60.3		dBFS
Effective Number of Bits (Note 8)	ENOB	f _{IN} = 30MHz		11.68			11.92			12.03		Bits
		f _{IN} = 105MHz	11.14	11.50		11.30	11.78		11.34	11.80		Bits
		f _{IN} = 190MHz		11.34			11.58			11.57		Bits
		f _{IN} = 363MHz		11.00			11.19			11.25		Bits
		f _{IN} = 461MHz		10.67			10.72			10.62		Bits
		f _{IN} = 605MHz		10.31			10.02			9.72		Bits

ISLA224P

Electrical Specifications All specifications apply under the following conditions unless otherwise noted: AVDD = 1.8V, OVDD = 1.8V, T_A = -40 °C to +85 °C (typical specifications at +25 °C), A_{IN} = -1dBFS, f_{SAMPLE} = Maximum Conversion Rate (per speed grade). **Boldface limits apply over the operating temperature range, -40 °C to +85 °C. (Continued)**

PARAMETER	SYMBOL	CONDITIONS	ISLA224P25			ISLA224P20			ISLA224P13			UNITS
			MIN (Note 5)	TYP	MAX (Note 5)	MIN (Note 5)	TYP	MAX (Note 5)	MIN (Note 5)	TYP	MAX (Note 5)	
Spurious-Free Dynamic Range (Note 8)	SFDR	f _{IN} = 30MHz		84		86		86			dBc	
		f _{IN} = 105MHz	71	79		72	82		71	79	dBc	
		f _{IN} = 190MHz		75			77			76	dBc	
		f _{IN} = 363MHz		73			75			79	dBc	
		f _{IN} = 461MHz		69			71			70	dBc	
		f _{IN} = 605MHz		67			64			62	dBc	
Spurious-Free Dynamic Range Excluding H2, H3 (Note 8)	SFDRX23	f _{IN} = 30MHz		88		95		99			dBc	
		f _{IN} = 105MHz		91		93		96			dBc	
		f _{IN} = 190MHz		88		91		92			dBc	
		f _{IN} = 363MHz		86		85		89			dBc	
		f _{IN} = 461MHz		88		82		87			dBc	
		f _{IN} = 605MHz		87		81		83			dBc	
Intermodulation Distortion	IMD	f _{IN} = 70MHz		87		87		86			dBFS	
		f _{IN} = 170MHz		96		102		100			dBFS	
Channel to Channel Isolation		f _{IN} = 10MHz		90		100		105			dBFS	
		f _{IN} = 121MHz		90		93		100			dBFS	
Word Error Rate	WER			10 ⁻¹²		10 ⁻¹²		10 ⁻¹²				
Full Power Bandwidth	FPBW			700		700		700			MHz	

NOTES:

- Compliance to datasheet limits is assured by one or more methods: production test, characterization and/or design.
- Digital Supply Current is dependent upon the capacitive loading of the digital outputs. I_{OVDD} specifications apply for 10pF load on each digital output.
- The DLL Range setting must be changed for low-speed operation.
- Minimum specification guaranteed when calibrated at +85 °C.

Digital Specifications Boldface limits apply over the operating temperature range, -40 °C to +85 °C.

PARAMETER	SYMBOL	CONDITIONS	MIN (Note 5)	TYP	MAX (Note 5)	UNITS
INPUTS						
Input Current High (RESETN)	I _{IH}	V _{IN} = 1.8V	0	1	10	μA
Input Current Low (RESETN)	I _{IL}	V _{IN} = 0V	-25	-12	-7	μA
Input Current High (SDIO)	I _{IH}	V _{IN} = 1.8V		4	12	μA
Input Current Low (SDIO)	I _{IL}	V _{IN} = 0V	-600	-415	-300	μA
Input Voltage High (SDIO, RESETN)	V _{IH}		1.17			V
Input Voltage Low (SDIO, RESETN)	V _{IL}				0.63	V
Input Current High (CLKDIV) (Note 9)	I _{IH}		16	25	34	μA
Input Current Low (CLKDIV)	I _{IL}		-34	-25	-16	μA
Input Capacitance	C _{DI}			3		pF

ISLA224P

Digital Specifications **Boldface limits apply over the operating temperature range, -40 °C to +85 °C. (Continued)**

PARAMETER	SYMBOL	CONDITIONS	MIN (Note 5)	TYP	MAX (Note 5)	UNITS
LVDS INPUTS (CLKDIVRSTP,CLKDIVRSTN)						
Input Common Mode Range	V_{ICM}		825		1575	mV
Input Differential Swing (peak to peak, single-ended)	V_{ID}		250		450	mV
CLKDIVRSTP Input Pull-down Resistance	R_{ipd}			100		k Ω
CLKDIVRSTN Input Pull-up Resistance	R_{ipu}			100		k Ω
LVDS OUTPUTS						
Differential Output Voltage (Note 10)	V_T	3mA Mode		612		mV _{p-p}
Output Offset Voltage	V_{OS}	3mA Mode	1120	1150	1200	mV
Output Rise Time	t_R			240		ps
Output Fall Time	t_F			240		ps
CMOS OUTPUTS						
Voltage Output High	V_{OH}	$I_{OH} = -500\mu A$	OVDD - 0.3	OVDD - 0.1		V
Voltage Output Low	V_{OL}	$I_{OL} = 1mA$		0.1	0.3	V
Output Rise Time	t_R			1.8		ns
Output Fall Time	t_F			1.4		ns

NOTES:

- The Tri-Level Inputs internal switching thresholds are approximately 0.43V and 1.34V. It is advised to float the inputs, tie to ground or AVDD depending on desired function.
- The voltage is expressed in peak-to-peak differential swing. The peak-to-peak singled-ended swing is 1/2 of the differential swing.

Timing Diagrams

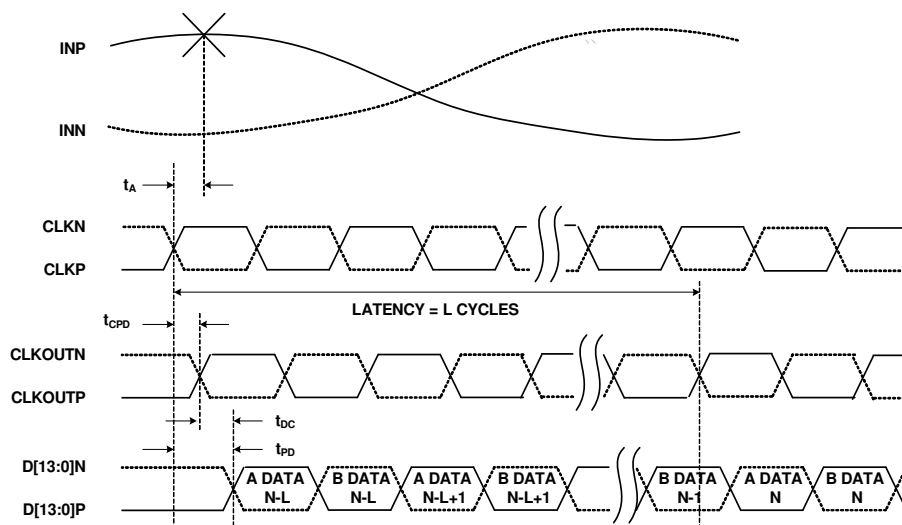

FIGURE 3. LVDS

Timing Diagrams (Continued)

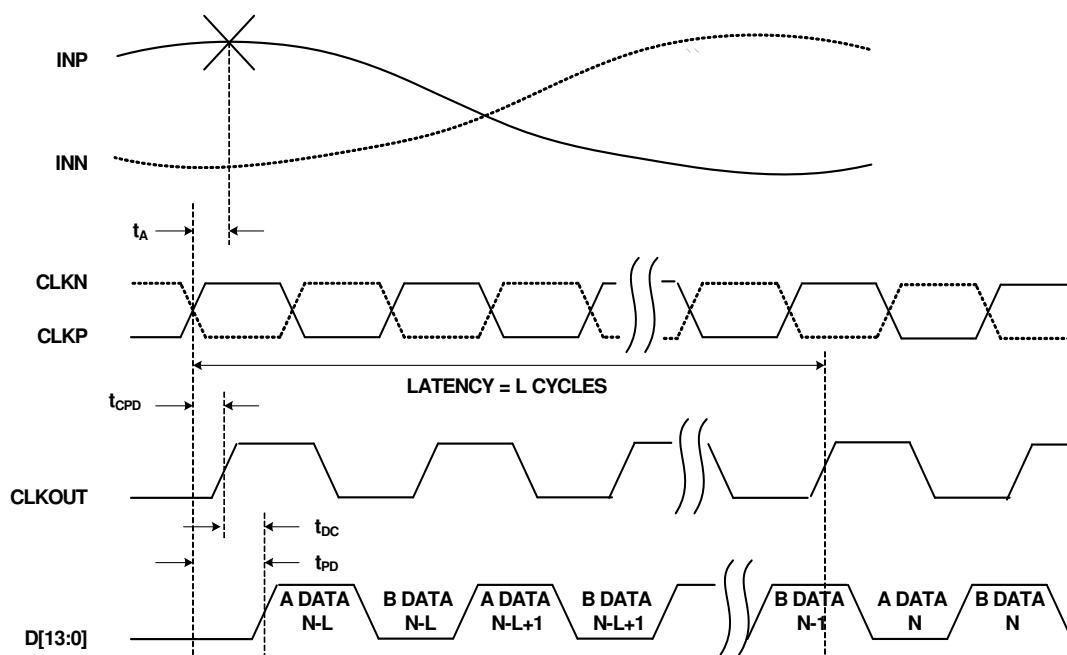

FIGURE 4. CMOS

Switching Specifications **Boldface limits apply over the operating temperature range, -40°C to +85°C.**

PARAMETER	SYMBOL	CONDITION	MIN (Note 5)	TYP	MAX (Note 5)	UNITS
ADC OUTPUT						
Aperture Delay	t_A			114		ps
RMS Aperture Jitter	j_A			75		fs
Input Clock to Output Clock Propagation Delay	t_{CPD}	AVDD, OVDD = 1.7V to 1.9V, $T_A = -40^\circ\text{C}$ to $+85^\circ\text{C}$	1.65	2.4	3	ns
		AVDD, OVDD = 1.8V, $T_A = +25^\circ\text{C}$	1.9	2.3	2.75	ns
Relative Input Clock to Output Clock Propagation Delay (Note 13)	dt_{CPD}	AVDD, OVDD = 1.7V to 1.9V, $T_A = -40^\circ\text{C}$ to $+85^\circ\text{C}$	-450		450	ps
Input Clock to Data Propagation Delay	t_{PD}		1.65	2.4	3.5	ns
Output Clock to Data Propagation Delay, LVDS Mode	t_{DC}	Rising/Falling Edge	-0.1	0.16	0.5	ns
Output Clock to Data Propagation Delay, CMOS Mode	t_{DC}	Rising/Falling Edge	-0.1	0.2	0.65	ns
Synchronous Clock Divider Reset Setup Time (with respect to the positive edge of CLKP)	t_{RSTS}		0.4	0.06		ns
Synchronous Clock Divider Reset Hold Time (with respect to the positive edge of CLKP)	t_{RSTH}			0.02	0.35	ns
Synchronous Clock Divider Reset Recovery Time	t_{RSTRT}	DLL recovery time after Synchronous Reset		52		μs
Latency (Pipeline Delay)	L			10		cycles

ISLA224P

Switching Specifications **Boldface limits apply over the operating temperature range, -40°C to +85°C. (Continued)**

PARAMETER	SYMBOL	CONDITION	MIN (Note 5)	TYP	MAX (Note 5)	UNITS
Overvoltage Recovery	t_{OVR}			1		cycles
SPI INTERFACE (Notes 11, 12)						
SCLK Period	t_{CLK}	Write Operation	7			cycles
	t_{CLK}	Read Operation	16			cycles
CSB↓ to SCLK↑ Setup Time	t_S	Read or Write	28			cycles
CSB↑ after SCLK↑ Hold Time	t_H	Write	5			cycles
CSB↑ after SCLK↓ Hold Time	t_{HR}	Read	16			cycles
Data Valid to SCLK↑ Setup Time	t_{DS}	Write	6			cycles
Data Valid after SCLK↑ Hold Time	t_{DH}	Read or Write			4	cycles
Data Valid after SCLK↓ Time	t_{DVR}	Read			5	cycles

NOTES:

- SPI Interface timing is directly proportional to the ADC sample period (t_S). Values above reflect multiples of a 4ns sample period, and must be scaled proportionally for lower sample rates. ADC sample clock must be running for SPI communication.
- The SPI may operate asynchronously with respect to the ADC sample clock.
- The relative propagation delay is the difference in propagation time between any two devices that are matched in temperature and voltage, and is specified over the full operating temperature and voltage range.

Typical Performance Curves

All Typical Performance Characteristics apply under the following conditions unless otherwise noted: AVDD = OVDD = 1.8V, $T_A = +25^\circ\text{C}$, $A_{IN} = -\text{dBFS}$, $f_{IN} = 105\text{MHz}$, $f_{SAMPLE} = 250\text{MSPS}$.

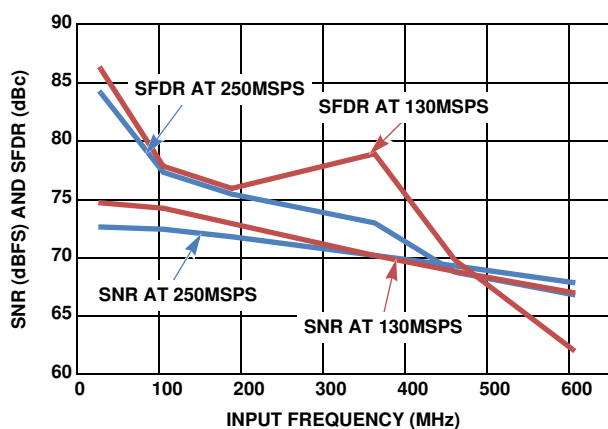

FIGURE 5. SNR AND SFDR vs f_{IN}

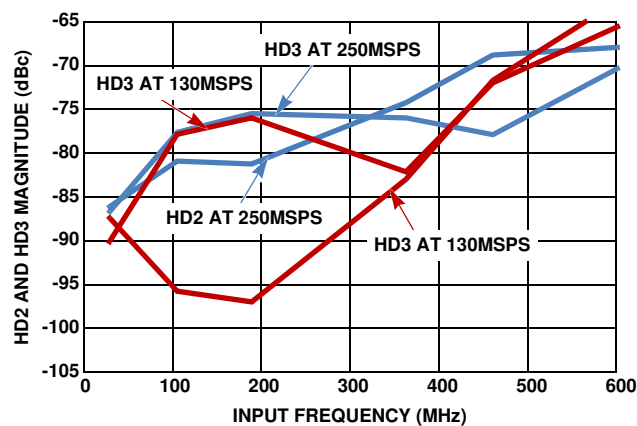

FIGURE 6. HD2 AND HD3 vs f_{IN}

Typical Performance Curves

All Typical Performance Characteristics apply under the following conditions unless otherwise noted: AVDD = OVDD = 1.8V, T_A = +25 °C, A_{IN} = -dBFS, f_{IN} = 105MHz, f_{SAMPLE} = 250MSPS. (Continued)

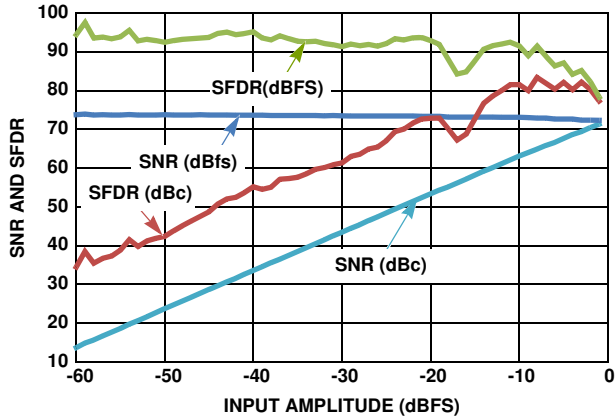

FIGURE 7. SNR AND SFDR vs A_{IN}

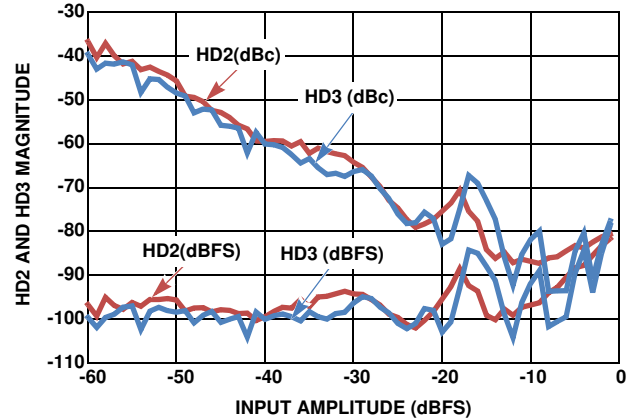

FIGURE 8. HD2 AND HD3 vs A_{IN}

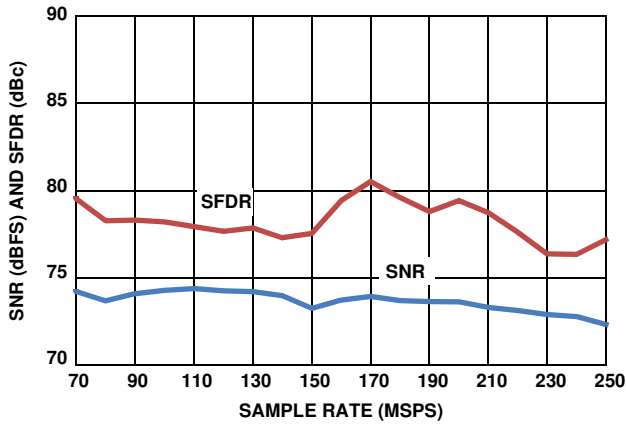

FIGURE 9. SNR AND SFDR vs f_{SAMPLE}

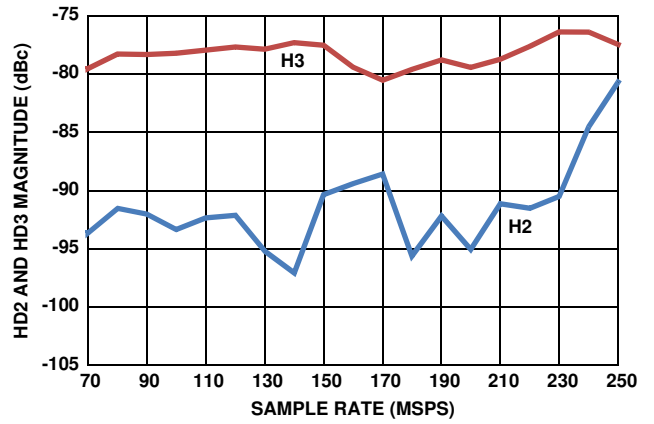

FIGURE 10. HD2 AND HD3 vs f_{SAMPLE}

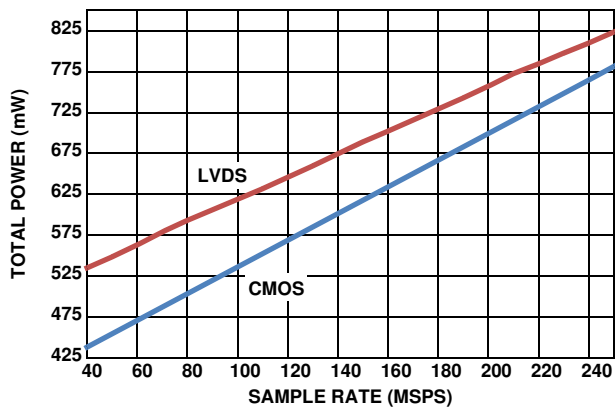

FIGURE 11. POWER vs f_{SAMPLE} IN 3mA LVDS AND CMOS MODES

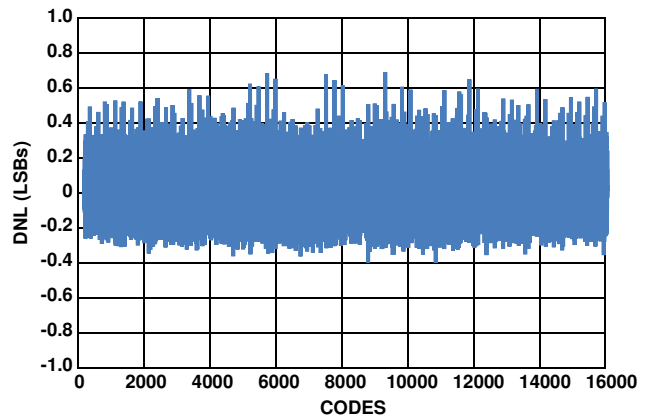

FIGURE 12. DIFFERENTIAL NONLINEARITY

Typical Performance Curves

All Typical Performance Characteristics apply under the following conditions unless otherwise noted: AVDD = OVDD = 1.8V, T_A = +25 °C, A_{IN} = -1 dBFS, f_{IN} = 105MHz, f_{SAMPLE} = 250MSPS. (Continued)

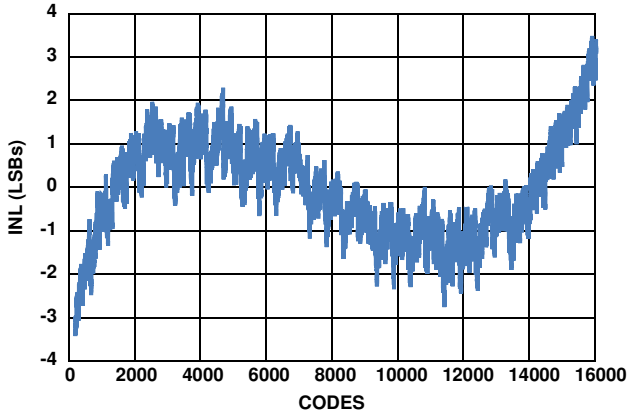

FIGURE 13. INTEGRAL NONLINEARITY

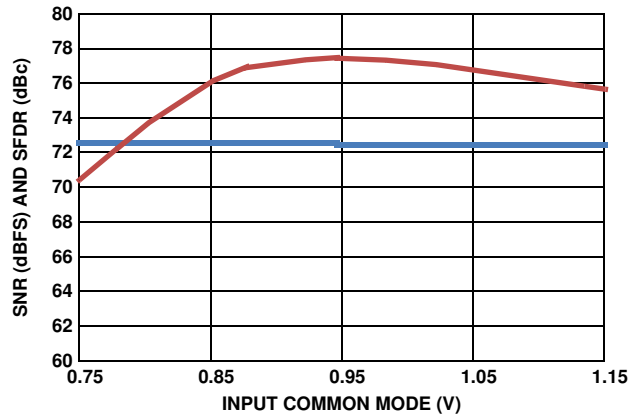

FIGURE 14. SNR AND SFDR vs VCM

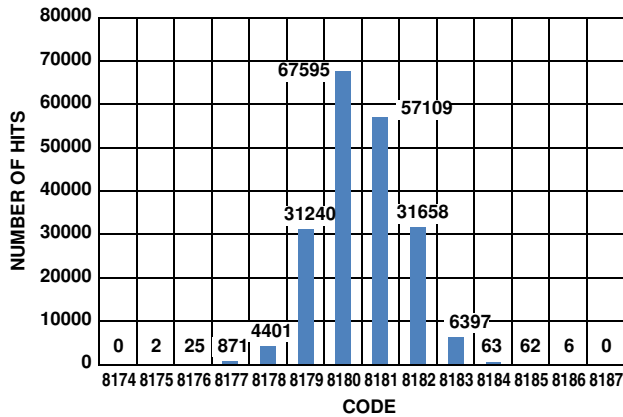

FIGURE 15. NOISE HISTOGRAM

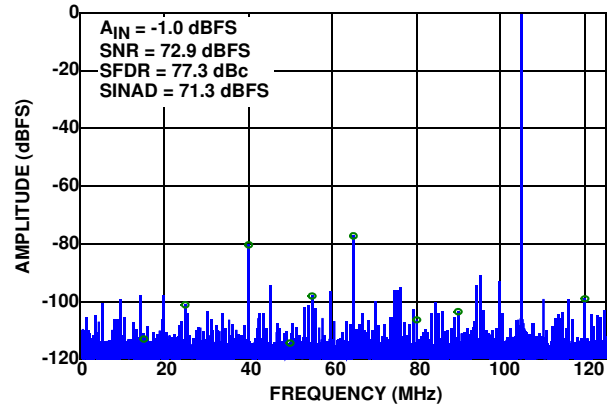

FIGURE 16. SINGLE-TONE SPECTRUM @ 105MHz

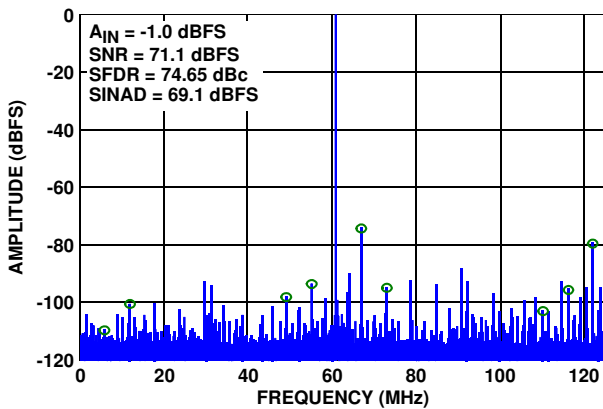

FIGURE 17. SINGLE-TONE SPECTRUM @ 190MHz

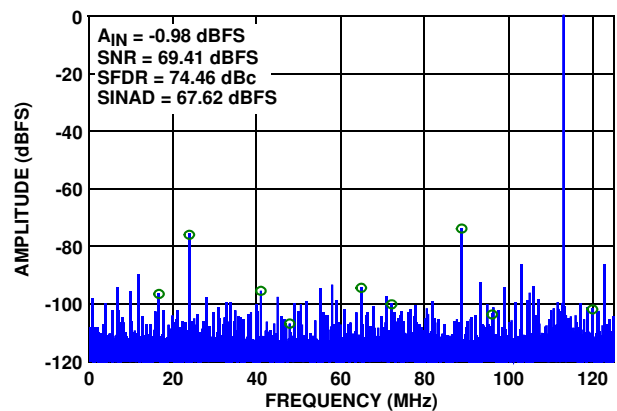

FIGURE 18. SINGLE-TONE SPECTRUM @ 363MHz

Typical Performance Curves

All Typical Performance Characteristics apply under the following conditions unless otherwise noted: AVDD = OVDD = 1.8V, $T_A = +25^\circ\text{C}$, $A_{IN} = -\text{dBFS}$, $f_{IN} = 105\text{MHz}$, $f_{SAMPLE} = 250\text{MSPS}$. (Continued)

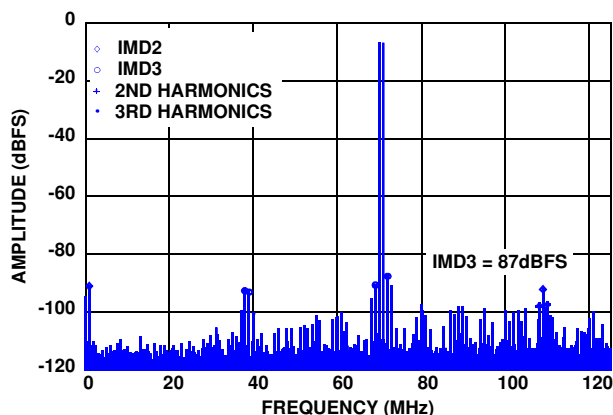

FIGURE 19. TWO-TONE SPECTRUM
(F1 = 70MHz, F2 = 71MHz AT -7dBFS)

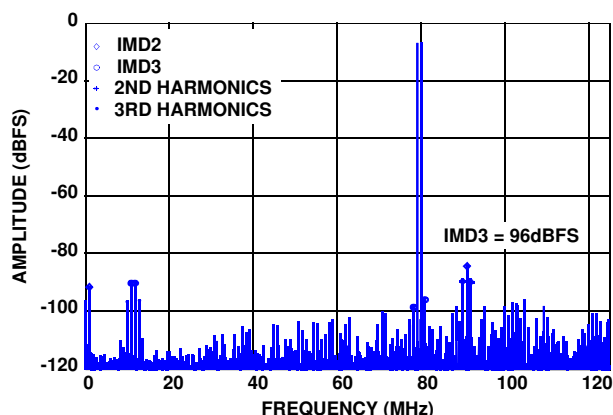

FIGURE 20. TWO-TONE SPECTRUM
(F1 = 170MHz, F2 = 171MHz AT -7dBFS)

Theory of Operation

Functional Description

The ISLA224P25 is based upon a 14-bit, 250MSPS A/D converter core that utilizes a pipelined successive approximation architecture (see Figure 21). The input voltage is captured by a Sample-Hold Amplifier (SHA) and converted to a unit of charge. Proprietary charge-domain techniques are used to successively compare the input to a series of reference charges. Decisions made during the successive approximation operations determine the digital code for each input value. Digital error correction is also applied, resulting in a total latency of 10 clock cycles. This is evident to the user as a latency between the start of a conversion and the data being available on the digital outputs.

Power-On Calibration

As mentioned previously, the cores perform a self-calibration at start-up. An internal power-on-reset (POR) circuit detects the supply voltage ramps and initiates the calibration when the analog and digital supply voltages are above a threshold. The following conditions must be adhered to for the power-on calibration to execute successfully:

- A frequency-stable conversion clock must be applied to the CLKP/CLKN pins
- DNC pins must not be connected
- SDO has an internal pull-up and should not be driven externally
- RESETN is pulled low by the ADC internally during POR. External driving of RESETN is optional.
- SPI communications must not be attempted

A user-initiated reset can subsequently be invoked in the event that the above conditions cannot be met at power-up.

After the power supply has stabilized the internal POR releases RESETN and an internal pull-up pulls it high, which starts the calibration sequence. If a subsequent user-initiated reset is desired, the RESETN pin should be connected to an open-drain driver with an off-state/high impedance state leakage of less than 0.5mA to assure exit from the reset state so calibration can start.

The calibration sequence is initiated on the rising edge of RESETN, as shown in Figure 22. Calibration status can be determined by reading the cal_status bit (LSB) at 0xB6. This bit is '0' during calibration and goes to a logic '1' when calibration is complete. The data outputs produce 0xCCCC during calibration; this can also be used to determine calibration status.

If the selectable clock divider is set to 1 (default), the output clock (CLKOUTP/CLKOUTN) will not be affected by the assertion of RESETN. If the selectable clock divider is set to 2 or 4, the output clock is set low while RESETN is asserted (low). Normal operation of the output clock resumes at the next input clock edge (CLKP/CLKN) after RESETN is de-asserted. At 250MSPS the nominal calibration time is 200ms, while the maximum calibration time is 550ms.

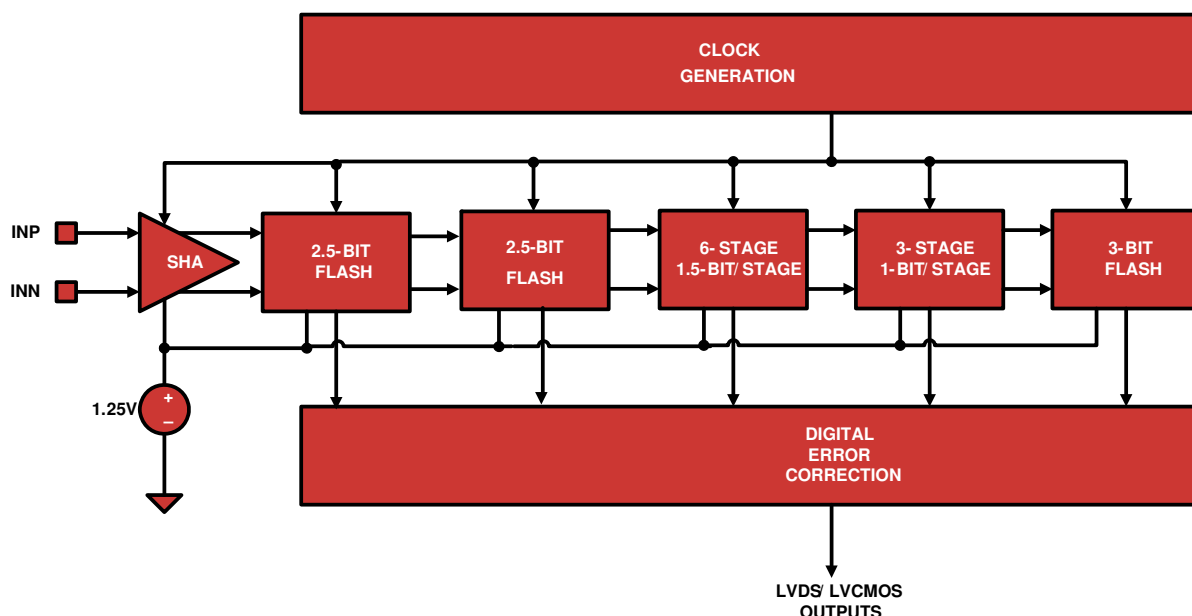

FIGURE 21. A/D CORE BLOCK DIAGRAM

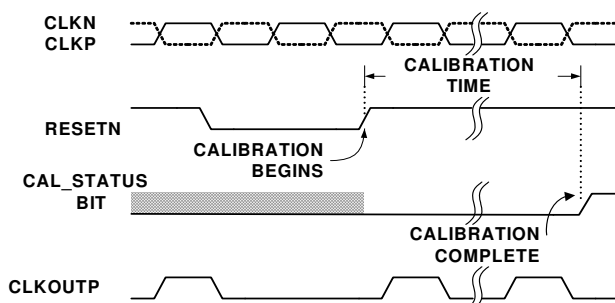

FIGURE 22. CALIBRATION TIMING

User Initiated Reset

Recalibration of the A/D can be initiated at any time by driving the RESETN pin low for a minimum of one clock cycle. An open-drain driver with a drive strength in its high impedance state of less than 0.5mA is recommended, as RESETN has an internal high impedance pull-up to OVDD. As is the case during power-on reset, RESETN and DNC pins must be in the proper state for the calibration to successfully execute.

The performance of the ISLA224P25 changes with variations in temperature, supply voltage or sample rate. The extent of these changes may necessitate recalibration, depending on system performance requirements. Best performance will be achieved by recalibrating the A/D under the environmental conditions at which it will operate.

A supply voltage variation of <100mV will generally result in an SNR change of <0.5dBFS and SFDR change of <3dBc.

In situations where the sample rate is not constant, best results will be obtained if the device is calibrated at the highest sample rate. Reducing the sample rate by less than 80MSPS will typically result in an SNR change of <0.5dBFS and an SFDR change of <3dBc.

Figures 23 through 28 show the effect of temperature on SNR and SFDR performance with power on calibration performed at -40°C, +25°C, and +85°C. Each plot shows the variation of SNR/SFDR across temperature after a single power on calibration at -40°C, +25°C and +85°C. Best performance is typically achieved by a user-initiated power on calibration at the operating conditions, as stated earlier. However, it can be seen that performance drift with temperature is not a very strong function of the temperature at which the power on calibration is performed.

Temperature Calibration

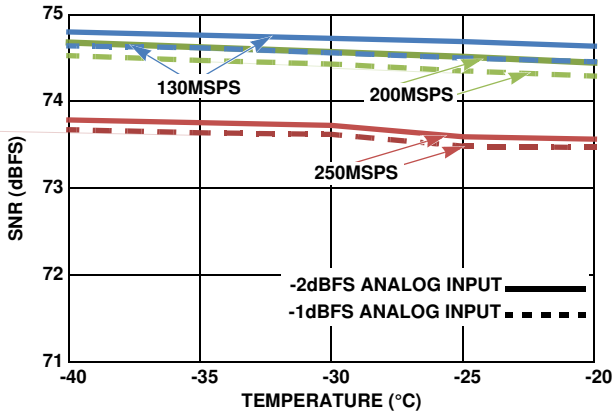

FIGURE 23. TYPICAL SNR PERFORMANCE vs TEMPERATURE, DEVICE CALIBRATED AT -40°C, $f_{IN} = 105\text{MHz}$

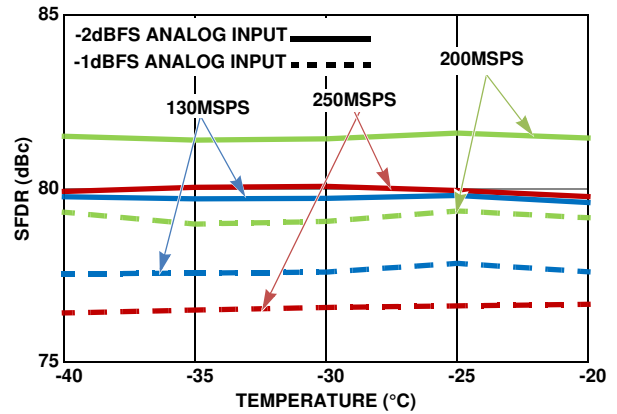

FIGURE 24. TYPICAL SFDR PERFORMANCE vs TEMPERATURE, DEVICE CALIBRATED AT -40°C, $f_{IN} = 105\text{MHz}$

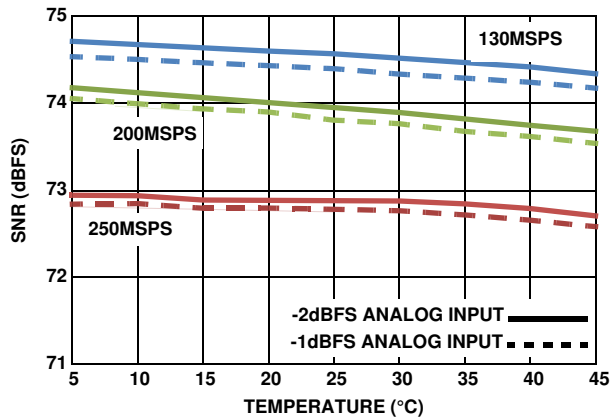

FIGURE 25. TYPICAL SNR PERFORMANCE vs TEMPERATURE, DEVICE CALIBRATED AT +25°C, $f_{IN} = 105\text{MHz}$

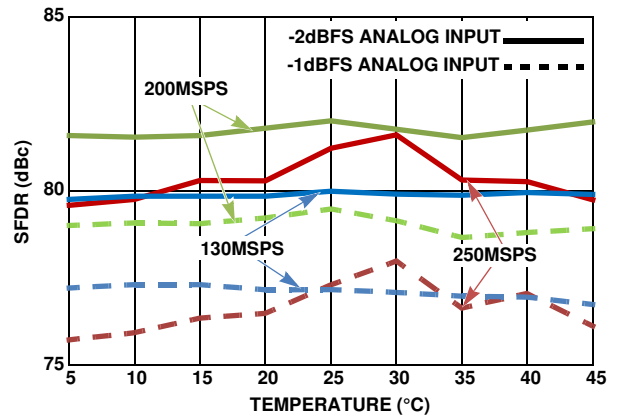

FIGURE 26. TYPICAL SFDR PERFORMANCE vs TEMPERATURE, DEVICE CALIBRATED AT +25°C, $f_{IN} = 105\text{MHz}$

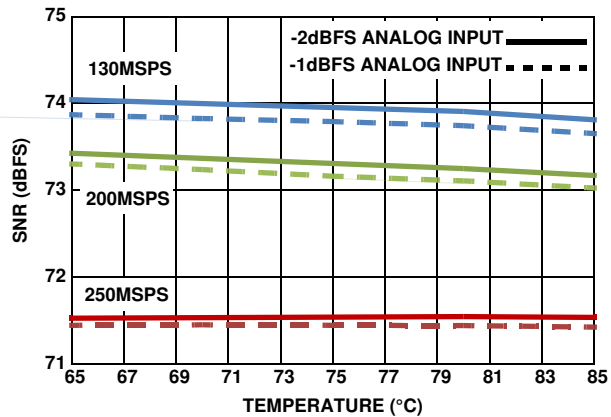

FIGURE 27. TYPICAL SNR PERFORMANCE vs TEMPERATURE, DEVICE CALIBRATED AT +85°C, $f_{IN} = 105\text{MHz}$

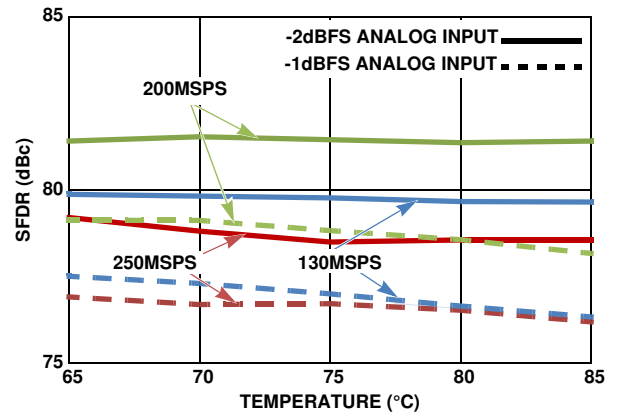

FIGURE 28. TYPICAL SFDR PERFORMANCE vs TEMPERATURE, DEVICE CALIBRATED AT +85°C, $f_{IN} = 105\text{MHz}$

Analog Input

A single fully differential input (VINP/VINN) connects to the sample and hold amplifier (SHA) of each unit A/D. The ideal full-scale input voltage is 2.0V, centered at the VCM voltage of 0.94V as shown in Figure 29.

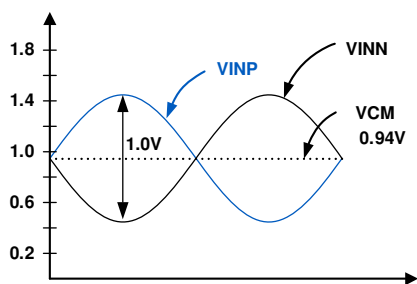

FIGURE 29. ANALOG INPUT RANGE

Best performance is obtained when the analog inputs are driven differentially. The common-mode output voltage, VCM, should be used to properly bias the inputs as shown in Figures 30 through 32. An RF transformer will give the best noise and distortion performance for wideband and/or high intermediate frequency (IF) inputs. Two different transformer input schemes are shown in Figures 30 and 31.

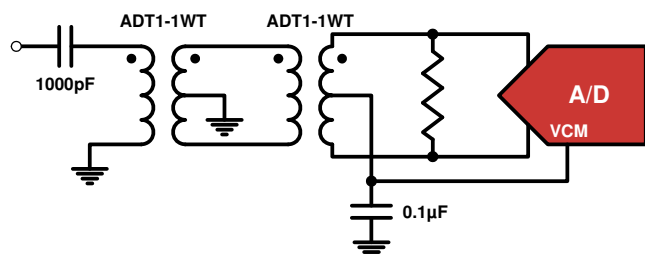

FIGURE 30. TRANSFORMER INPUT FOR GENERAL PURPOSE APPLICATIONS

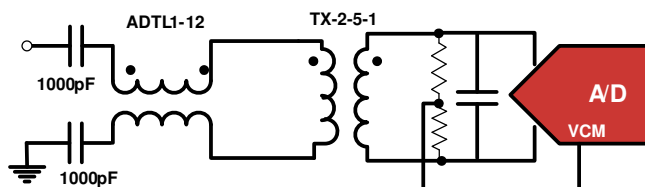

FIGURE 31. TRANSMISSION-LINE TRANSFORMER INPUT FOR HIGH IF APPLICATIONS

This dual transformer scheme is used to improve common-mode rejection, which keeps the common-mode level of the input matched to VCM. The value of the shunt resistor should be determined based on the desired load impedance. The differential input resistance of the ISLA224P25 is 600Ω.

The SHA design uses a switched capacitor input stage (see Figure 45), which creates current spikes when the sampling capacitance is reconnected to the input voltage. This causes a disturbance at the input which must settle before the next sampling point. Lower source impedance will result in faster settling and improved performance. Therefore a 2:1 or 1:1 transformer and low shunt resistance are recommended for optimal performance.

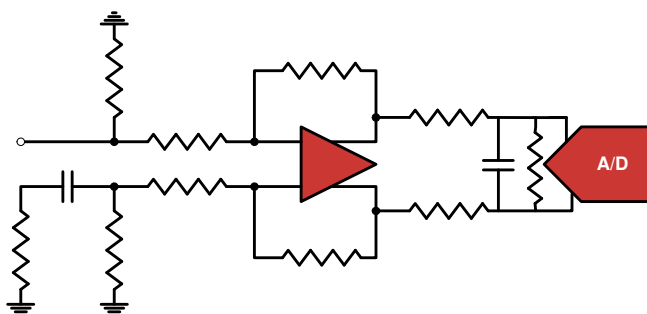

FIGURE 32. DIFFERENTIAL AMPLIFIER INPUT

A differential amplifier, as shown in the simplified block diagram in Figure 32, can be used in applications that require DC-coupling. In this configuration, the amplifier will typically dominate the achievable SNR and distortion performance. Intersil's new ISL552xx differential amplifier family can also be used in certain AC applications with minimal performance degradation. Contact the factory for more information.

Clock Input

The clock input circuit is a differential pair (see Figure 46). Driving these inputs with a high level (up to 1.8V_{P-P} on each input) sine or square wave will provide the lowest jitter performance. A transformer with 4:1 impedance ratio will provide increased drive levels. The clock input is functional with AC-coupled LVDS, LVPECL, and CML drive levels. To maintain the lowest possible aperture jitter, it is recommended to have high slew rate at the zero crossing of the differential clock input signal.

The recommended drive circuit is shown in Figure 33. A duty range of 40% to 60% is acceptable. The clock can be driven single-ended, but this will reduce the edge rate and may impact SNR performance. The clock inputs are internally self-biased to AVDD/2 to facilitate AC coupling.

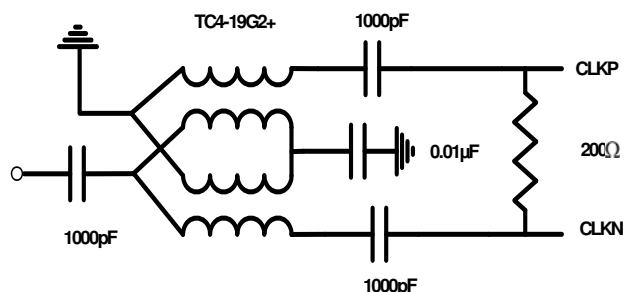

FIGURE 33. RECOMMENDED CLOCK DRIVE

A selectable 2x or 4x frequency divider is provided in series with the clock input. The divider can be used in the 2x mode with a sample clock equal to twice the desired sample rate or in 4x mode with a sample clock equal to four times the desired sample rate. This allows the use of the Phase Slip feature, which enables synchronization of multiple ADCs. The Phase Slip feature can be used as an alternative to using the CLKDIVRST pins to synchronize ADCs in a multiple ADC system.

TABLE 1. CLKDIV PIN SETTINGS

CLKDIV PIN	DIVIDE RATIO
AVSS	2
Float	1
AVDD	4

The clock divider can also be controlled through the SPI port, which overrides the CLKDIV pin setting. See “SPI Physical Interface” on page 24. A delay-locked loop (DLL) generates internal clock signals for various stages within the charge pipeline. If the frequency of the input clock changes, the DLL may take up to 52µs to regain lock at 250MSPS. The lock time is inversely proportional to the sample rate.

The DLL has two ranges of operation, slow and fast. The slow range can be used for sample rates between 40MSPS and 100MSPS, while the default fast range can be used from 80MSPS to the maximum specified sample rate.

Jitter

In a sampled data system, clock jitter directly impacts the achievable SNR performance. The theoretical relationship between clock jitter (t_j) and SNR is shown in Equation 1 and is illustrated in Figure 34.

$$SNR = 20 \log_{10} \left(\frac{1}{2\pi f_{IN} t_j} \right) \quad (EQ. 1)$$

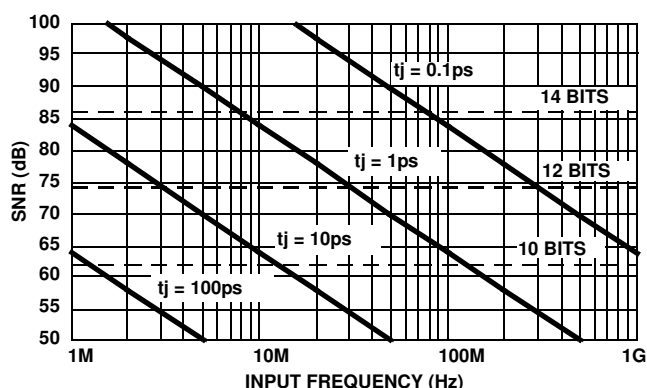

FIGURE 34. SNR vs CLOCK JITTER

This relationship shows the SNR that would be achieved if clock jitter were the only non-ideal factor. In reality, achievable SNR is limited by internal factors such as linearity, aperture jitter and thermal noise. Internal aperture jitter is the uncertainty in the sampling instant shown in Figure 3. The internal aperture jitter combines with the input clock jitter in a root-sum-square fashion, since they are not statistically correlated, and this determines the total jitter in the system. The total jitter, combined with other noise sources, then determines the achievable SNR.

Voltage Reference

A temperature compensated internal voltage reference provides the reference charges used in the successive approximation operations. The full-scale range of each A/D is proportional to the reference voltage. The nominal value of the voltage reference is 1.25V.

Digital Outputs

Output data is available as a parallel bus in LVDS-compatible(default) or CMOS modes. In either case, the data is presented in double data rate (DDR) format. Figures 3 and 4 show the timing relationships for LVDS and CMOS modes, respectively.

Additionally, the drive current for LVDS mode can be set to a nominal 3mA(default) or a power-saving 2mA. The lower current setting can be used in designs where the receiver is in close physical proximity to the A/D. The applicability of this setting is dependent upon the PCB layout, therefore the user should experiment to determine if performance degradation is observed.

The output mode can be controlled through the SPI port, by writing to address 0x73, see “Serial Peripheral Interface” on page 24.

An external resistor creates the bias for the LVDS drivers. A 10kΩ, 1% resistor must be connected from the RLVDSP pin to OVSS.

Power Dissipation

The power dissipated by the ISLA224P25 is primarily dependent on the sample rate and the output modes: LVDS vs CMOS and DDR vs SDR. There is a static bias in the analog supply, while the remaining power dissipation is linearly related to the sample rate. The output supply dissipation changes to a lesser degree in LVDS mode, but is more strongly related to the clock frequency in CMOS mode.

Nap/Sleep

Portions of the device may be shut down to save power during times when operation of the A/D is not required. Two power saving modes are available: Nap, and Sleep. Nap mode reduces power dissipation to <103mW while Sleep mode reduces power dissipation to <19mW.

All digital outputs (Data, CLKOUT and OR) are placed in a high impedance state during Nap or Sleep. The input clock should remain running and at a fixed frequency during Nap or Sleep, and CSB should be high. Recovery time from Nap mode will increase if the clock is stopped, since the internal DLL can take up to 52µs to regain lock at 250MSPS.

By default after the device is powered on, the operational state is controlled by the NAPSLP pin as shown in Table 2.

TABLE 2. NAPSLP PIN SETTINGS

NAPSLP PIN	MODE
AVSS	Normal
Float	Sleep
AVDD	Nap

The power-down mode can also be controlled through the SPI port, which overrides the NAPSLP pin setting. Details on this are contained in “Serial Peripheral Interface” on page 24.

Data Format

Output data can be presented in three formats: two's complement (default), Gray code and offset binary. The data format can also be controlled through the SPI port, by writing to address 0x73. Details on this are contained in "Serial Peripheral Interface" on page 24.

Offset binary coding maps the most negative input voltage to code 0x000 (all zeros) and the most positive input to 0xFF (all ones). Two's complement coding simply complements the MSB of the offset binary representation.

When calculating Gray code the MSB is unchanged. The remaining bits are computed as the XOR of the current bit position and the next most significant bit. Figure 35 shows this operation.

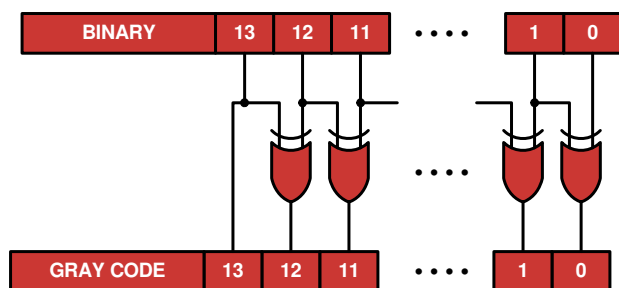

FIGURE 35. BINARY TO GRAY CODE CONVERSION

Converting back to offset binary from Gray code must be done recursively, using the result of each bit for the next lower bit as shown in Figure 36.

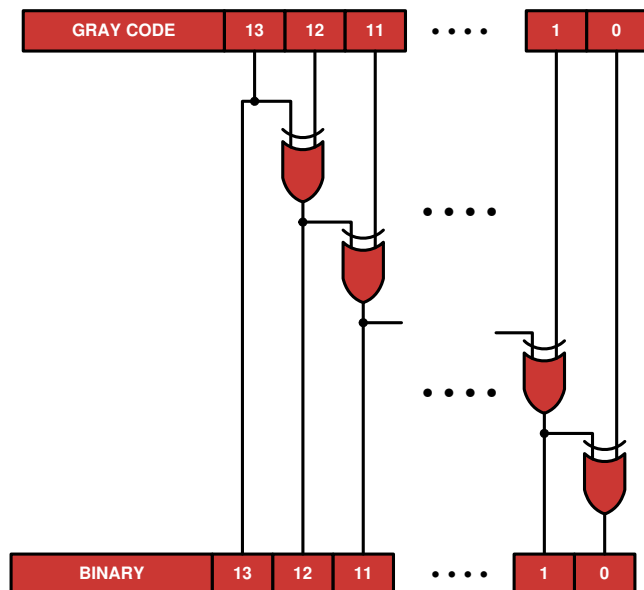

FIGURE 36. GRAY CODE TO BINARY CONVERSION

Mapping of the input voltage to the various data formats is shown in Table 3.

TABLE 3. INPUT VOLTAGE TO OUTPUT CODE MAPPING

INPUT VOLTAGE	OFFSET BINARY	TWO'S COMPLEMENT	GRAY CODE
-Full Scale	00 0000 0000 0000	10 0000 0000 0000	00 0000 0000 0000
-Full Scale + 1LSB	00 0000 0000 0001	10 0000 0000 0001	00 0000 0000 0001
Mid-Scale	10 0000 0000 0000	00 0000 0000 0000	11 0000 0000 0000
+Full Scale - 1LSB	11 1111 1111 1110	01 1111 1111 1110	10 0000 0000 0001
+Full Scale	11 1111 1111 1111	01 1111 1111 1111	10 0000 0000 0000

Clock Divider Synchronous Reset

If the selectable clock divider is used, the ADC's internal sample clock will be at half the frequency (DIV = 2) or one quarter the frequency (DIV = 4) of the device clock. The phase relationship between the sample clock and the device clock is initially indeterminate. An output clock (CLKOUTP, CLKOUTN) is provided to facilitate latching of the sampled data and estimation of the internal sample clock's phase. The output clock has a fixed phase relationship to the sample clock. When the selectable clock divider is set to 2 or 4, the output clock's phase relationship to the sample clock remains fixed but is initially indeterminate with respect to the device clock. When the selectable clock divider is set to 2 or 4, the synchronous clock divider reset feature allows the phase of the internal sample clock and the output clock to be synchronized (refer to Figure 37) with respect to the device clock. This simplifies data capture in systems employing multiple A/Ds where sampling of the inputs is desired to be synchronous.

The reset signal must be well-timed with respect to the sample clock (See "Switching Specifications" on page 12).

A 100Ω differential termination resistor must be supplied between CLKDIVRSTP and CLKDIVRSTN, external to the ADC, (on the PCB) and should be located as close to the CLKDIVRSTP/N pins as possible.

ISLA224P

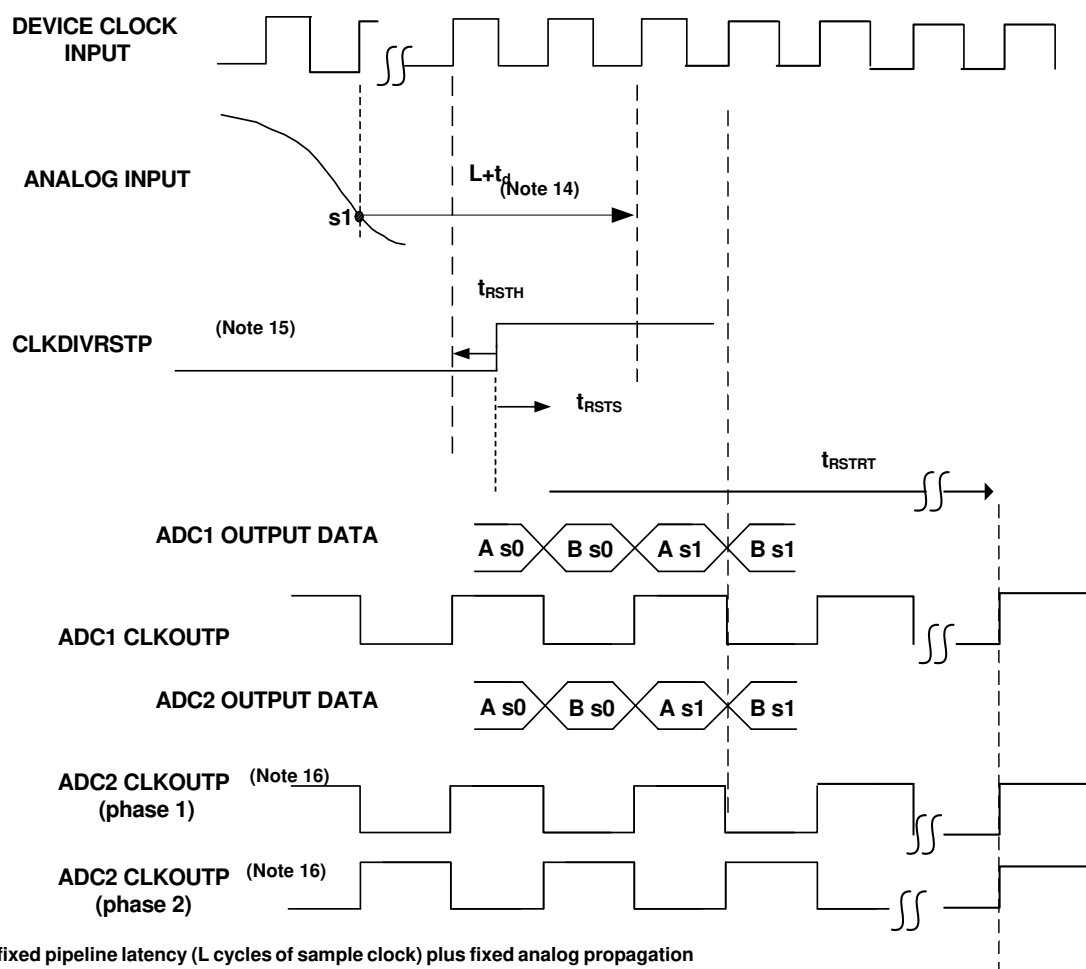

NOTES:

- 14. Delay equals fixed pipeline latency (L cycles of sample clock) plus fixed analog propagation delay, t_d .
- 15. CLKDIVRSTP setup and hold times are with respect to input sample clock rising edge. CLKDIVRSTN is not shown, but must be driven, and is the compliment of CLKDIVRSTP.
- 16. Either Output Clock Phase (phase 1 or phase 2) equally likely prior to synchronization.

FIGURE 37. SYNCHRONOUS RESET OPERATION, CLOCK DIVIDE = 2

ISLA224P

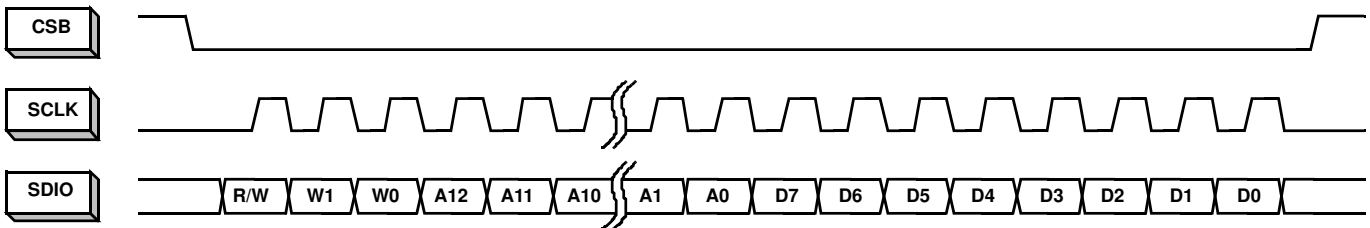

FIGURE 38. MSB-FIRST ADDRESSING

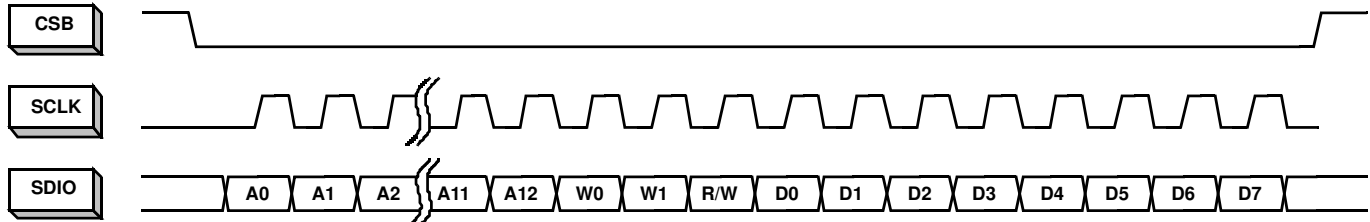
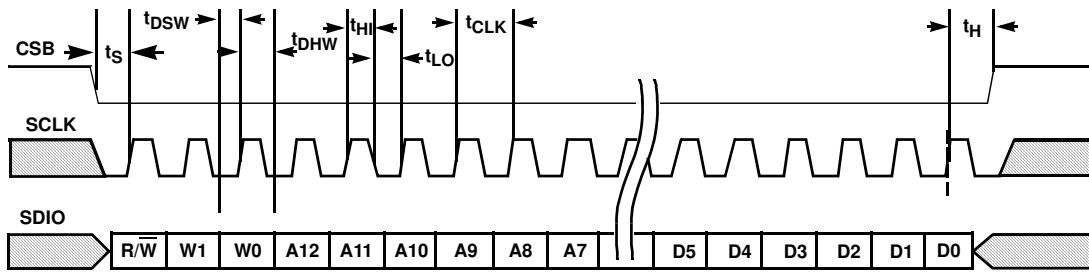
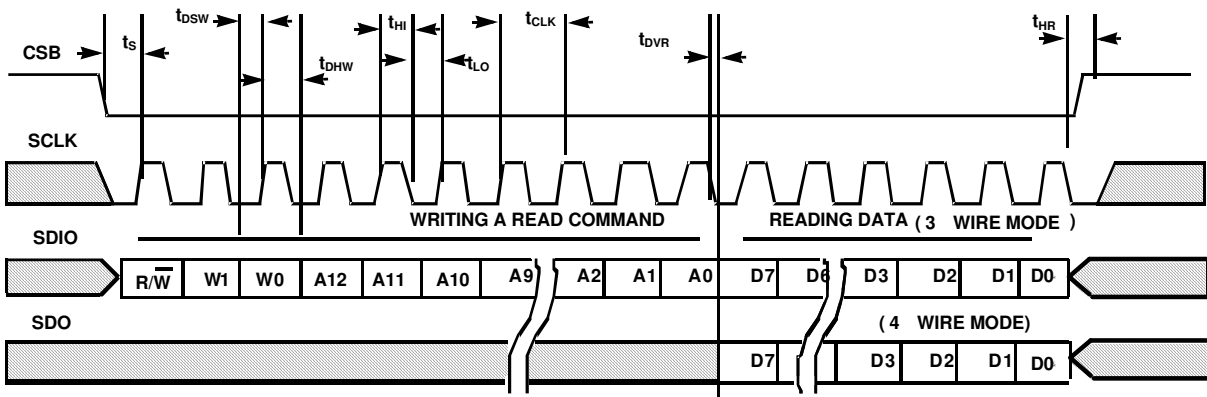

FIGURE 39. LSB-FIRST ADDRESSING



SPI WRITE

FIGURE 40. SPI WRITE



SPI READ

FIGURE 41. SPI READ

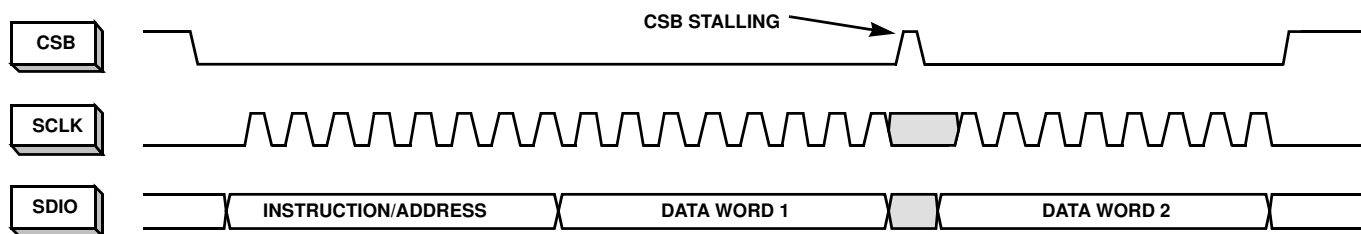

FIGURE 42. 2-BYTE TRANSFER

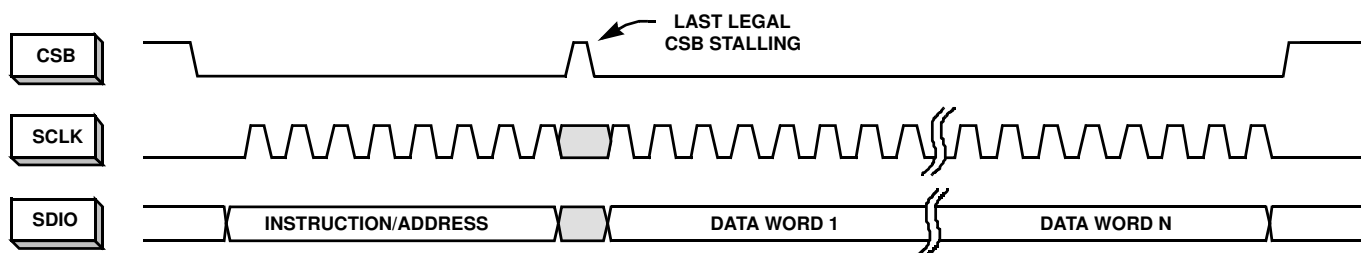

FIGURE 43. N-BYTE TRANSFER

Serial Peripheral Interface

A serial peripheral interface (SPI) bus is used to facilitate configuration of the device and to optimize performance. The SPI bus consists of chip select (CSB), serial clock (SCLK) serial data output (SDO), and serial data input/output (SDIO). The maximum SCLK rate is equal to the A/D sample rate (f_{SAMPLE}) divided by 32 for write operations and f_{SAMPLE} divided by 132 for reads. At $f_{\text{SAMPLE}} = 250\text{MHz}$, maximum SCLK is 15.63MHz for writing and 3.79MHz for read operations. There is no minimum SCLK rate.

The following sections describe various registers that are used to configure the SPI or adjust performance or functional parameters. Many registers in the available address space (0x00 to 0xFF) are not defined in this document. Additionally, within a defined register there may be certain bits or bit combinations that are reserved. Undefined registers and undefined values within defined registers are reserved and should not be selected. Setting any reserved register or value may produce indeterminate results.

SPI Physical Interface

The serial clock pin (SCLK) provides synchronization for the data transfer. By default, all data is presented on the serial data input/output (SDIO) pin in three-wire mode. The state of the SDIO pin is set automatically in the communication protocol (described in the following). A dedicated serial data output pin (SDO) can be activated by setting 0x00[7] high to allow operation in four-wire mode.

The SPI port operates in a half duplex master/slave configuration, with the ISLA224P25 functioning as a slave. Multiple slave devices can interface to a single master in three-wire mode only, since the SDO output of an unaddressed device is asserted in four wire mode.

The chip-select bar (CSB) pin determines when a slave device is being addressed. Multiple slave devices can be written to concurrently, but only one slave device can be read from at a given time (again, only in three-wire mode). If multiple slave

devices are selected for reading at the same time, the results will be indeterminate.

The communication protocol begins with an instruction/address phase. The first rising SCLK edge following a high-to-low transition on CSB determines the beginning of the two-byte instruction/address command; SCLK must be static low before the CSB transition. Data can be presented in MSB-first order or LSB-first order. The default is MSB-first, but this can be changed by setting 0x00[6] high. Figures 38 and 39 show the appropriate bit ordering for the MSB-first and LSB-first modes, respectively. In MSB-first mode, the address is incremented for multi-byte transfers, while in LSB-first mode it's decremented.

In the default mode, the MSB is R/W, which determines if the data is to be read (active high) or written. The next two bits, W1 and W0, determine the number of data bytes to be read or written (see Table 4). The lower 13 bits contain the first address for the data transfer. This relationship is illustrated in Figure 40, and timing values are given in "Switching Specifications" on page 12.

After the instruction/address bytes have been read, the appropriate number of data bytes are written to or read from the A/D (based on the R/W bit status). The data transfer will continue as long as CSB remains low and SCLK is active. Stalling of the CSB pin is allowed at any byte boundary (instruction/address or data) if the number of bytes being transferred is three or less. For transfers of four bytes or more, CSB is allowed to stall in the middle of the instruction/address bytes or before the first data byte. If CSB transitions to a high state after that point the state machine will reset and terminate the data transfer.

TABLE 4. BYTE TRANSFER SELECTION

[W1:W0]	BYTES TRANSFERRED
00	1
01	2
10	3
11	4 or more

Figures 42 and 43 illustrate the timing relationships for 2-byte and N-byte transfers, respectively. The operation for a 3-byte transfer can be inferred from these diagrams.

SPI Configuration

ADDRESS 0X00: CHIP_PORT_CONFIG

Bit ordering and SPI reset are controlled by this register. Bit order can be selected as MSB to LSB (MSB first) or LSB to MSB (LSB first) to accommodate various micro controllers.

Bit 7 SDO Active

Bit 6 LSB First

Setting this bit high configures the SPI to interpret serial data as arriving in LSB to MSB order.

Bit 5 Soft Reset

Setting this bit high resets all SPI registers to default values.

Bit 4 Reserved

This bit should always be set high.

Bits 3:0

These bits should always mirror bits 4:7 to avoid ambiguity in bit ordering.

ADDRESS 0X02: BURST_END

If a series of sequential registers are to be set, burst mode can improve throughput by eliminating redundant addressing. The burst is ended by pulling the CSB pin high. Setting the burst_end address determines the end of the transfer. During a write operation, the user must be cautious to transmit the correct number of bytes based on the starting and ending addresses.

Bits 7:0 Burst End Address

This register value determines the ending address of the burst data.

Device Information

ADDRESS 0X08: CHIP_ID

ADDRESS 0X09: CHIP_VERSION

The generic die identifier and a revision number, respectively, can be read from these two registers.

Device Configuration/Control

A common SPI map, which can accommodate single-channel or multi-channel devices, is used for all Intersil A/D products.

ADDRESS 0X20: OFFSET_COARSE_ADC0

ADDRESS 0X21: OFFSET_FINE_ADC0

The input offset of the A/D core can be adjusted in fine and coarse steps. Both adjustments are made via an 8-bit word as detailed in Table 5. The data format is twos complement.

The default value of each register will be the result of the self-calibration after initial power-up. If a register is to be incremented or decremented, the user should first read the register value then write the incremented or decremented value back to the same register. Bit 0 in register 0xFE must be set high to enable updates written to 0x20 and 0x21 to be used by the ADC (see description for 0xFE).

TABLE 5. OFFSET ADJUSTMENTS

PARAMETER	0x20[7:0] COARSE OFFSET	0x21[7:0] FINE OFFSET
Steps	255	255
-Full Scale (0x00)	-133LSB (-47mV)	-5LSB (-1.75mV)
Mid-Scale (0x80)	0.0LSB (0.0mV)	0.0LSB
+Full Scale (0xFF)	+133LSB (+47mV)	+5LSB (+1.75mV)
Nominal Step Size	1.04LSB (0.37mV)	0.04LSB (0.014mV)

ADDRESS 0X22: GAIN_COARSE_ADC0

ADDRESS 0X23: GAIN_MEDIUM_ADC0

ADDRESS 0X24: GAIN_FINE_ADC0

Gain of the A/D core can be adjusted in coarse, medium and fine steps. Coarse gain is a 4-bit adjustment while medium and fine are 8-bit. Multiple Coarse Gain Bits can be set for a total adjustment range of $\pm 4.2\%$. ('0011' $\cong -4.2\%$ and '1100' $\cong +4.2\%$) It is recommended to use one of the coarse gain settings (-4.2%, -2.8%, -1.4%, 0, 1.4%, 2.8%, 4.2%) and fine-tune the gain using the registers at 0x0023 and 0x24.

The default value of each register will be the result of the self-calibration after initial power-up. If a register is to be incremented or decremented, the user should first read the register value then write the incremented or decremented value back to the same register. Bit 0 in register 0xFE must be set high to enable updates written to 0x23 and 0x24 to be used by the ADC (see description for 0xFE).

TABLE 6. COARSE GAIN ADJUSTMENT

0x22[3:0] core 0 0x26[3:0] core 1	NOMINAL COARSE GAIN ADJUST (%)
Bit3	+2.8
Bit2	+1.4
Bit1	-2.8
Bit0	-1.4