



Chipsmall Limited consists of a professional team with an average of over 10 year of expertise in the distribution of electronic components. Based in Hongkong, we have already established firm and mutual-benefit business relationships with customers from,Europe,America and south Asia,supplying obsolete and hard-to-find components to meet their specific needs.

With the principle of “Quality Parts,Customers Priority,Honest Operation,and Considerate Service”,our business mainly focus on the distribution of electronic components. Line cards we deal with include Microchip,ALPS,ROHM,Xilinx,Pulse,ON,Everlight and Freescale. Main products comprise IC,Modules,Potentiometer,IC Socket,Relay,Connector.Our parts cover such applications as commercial,industrial, and automotives areas.

We are looking forward to setting up business relationship with you and hope to provide you with the best service and solution. Let us make a better world for our industry!



Contact us

Tel: +86-755-8981 8866 Fax: +86-755-8427 6832

Email & Skype: info@chipsmall.com Web: www.chipsmall.com

Address: A1208, Overseas Decoration Building, #122 Zhenhua RD., Futian, Shenzhen, China



IWR-5

Five Channel Wireless Receiver



- Pairs with the IWPT wireless pressure transducer
- User-selectable 1-5V or 4-20mA receiver output
- Clean contact output for process, low battery or loss of signal alarm function
- Simple software or DIL switch pairing with IWPT pressure transducers
- Up to 750m range, line-of-sight
- 12 to 32 Vdc powered
- End-to-end accuracy of $\pm 0.25\%$ FS BFSL
- LED indication of wireless link
- DIN rail or wall mounting kits available
- Single channel receiver available - see data sheet IWR-1

Description

The IWR-5 is a five channel receiver designed to pair with the IWPT series of wireless pressure transducers to form a cost effective replacement of the traditional wired pressure transducer. This offers a low cost solution to inaccessible or expensive installation environment. The receiver has user selectable voltage or mA outputs corresponding to the calibrated pressure range of the remote Wireless Pressure Transducers and 5A rated changeover contacts for alarm functionality. User channel configuration is possible with the use of the program, IWR-Set, which ensures minimal user set-up time and thus ensures a simple solution to multi-channel pressure measurement applications. With the standard 0dBi antenna, a line-of-sight range of up to 500m can be achieved and, using the optional 3dBi antenna, up to 750m (LOS) is achievable.

Electrical Protection

Outputs (5 off)	User selectable 1-5V or 4-20mA
Alarm Output (1 off)	5 Amp rated changeover contacts
Receiver Update Rate*	10 seconds as standard. Alternative user settable rates : - 1, 5, 10 and 30 seconds

*Consult IWPT Installation manual and data sheet for set-up of alternative transmission rates.

Enclosure Specifications

Dimensions	160 mm x 80 mm x 57 mm
Material*	Light grey ABS (RAL7035)
Protection Class	IP65
Weight	255g inc. 0dBi antenna (+12g with 3dBi)
Installation Position**	Any

* Other materials on request

** Consult Installation Manual to ensure adequate signal path between transmitter and receiver

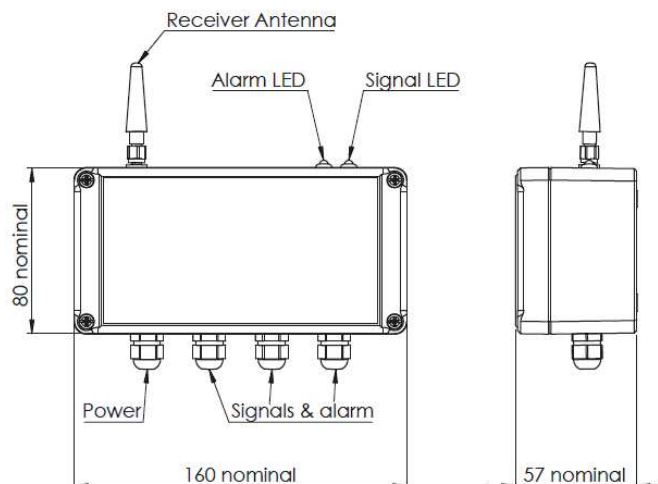

Receiver Input

*Receiver Frequency	2.4GHz
System Channel	Standard setting, however user adjustable in multiple instrument systems.
Antenna	Enclosure mounted 0dBi
*Compliant with EN 300 328, V1.8.1	

System Performance (@ +20°C)

Accuracy	$\leq \pm 0.25\%$ FS BFSL
Setting Errors (offsets)*	Zero and Full Scale $\leq \pm 0.5\%$ FS

* End-to-end zero tare function available, see user manual.

Instrument Power Source

DC Power	12 to 32Vdc
----------	-------------

Temperature Ratings

Operating Temperature	-10°C to +50°C
Storage Temperature	-20°C to +80°C

Ordering Codes

Pressure Transducer:	See IWPT & IWPTL datasheets
Single Channel Receiver:	IWR-1
Five Channel Receiver:	IWR-5
Five Channel Configuration Software*	IWR-Set
3dBi Antenna (enclosure mount)	IANT-3

*Download user configuration software here: - <http://www.cynergy3.com/cookie-download/file/nojs/12901/10766/config>

ISO9001 CERTIFIED

IWR-5 2016

© 2016 Cynergy3 Components, All Rights Reserved. Specifications are subject to change without prior notice. Cynergy3 Components and the Cynergy3 Components logo are trademarks of Cynergy3 Components Limited.

www.cynergy3.com



Cynergy3 Components Ltd.
7 Cobham Road
Ferndown Industrial Estate
Wimborne, Dorset BH21 7PE
Telephone +44 (0) 1202 897969
Email: sales@cynergy3.com