



Chipsmall Limited consists of a professional team with an average of over 10 year of expertise in the distribution of electronic components. Based in Hongkong, we have already established firm and mutual-benefit business relationships with customers from,Europe,America and south Asia,supplying obsolete and hard-to-find components to meet their specific needs.

With the principle of “Quality Parts,Customers Priority,Honest Operation,and Considerate Service”,our business mainly focus on the distribution of electronic components. Line cards we deal with include Microchip,ALPS,ROHM,Xilinx,Pulse,ON,Everlight and Freescale. Main products comprise IC,Modules,Potentiometer,IC Socket,Relay,Connector.Our parts cover such applications as commercial,industrial, and automotives areas.

We are looking forward to setting up business relationship with you and hope to provide you with the best service and solution. Let us make a better world for our industry!



Contact us

Tel: +86-755-8981 8866 Fax: +86-755-8427 6832

Email & Skype: info@chipsmall.com Web: www.chipsmall.com

Address: A1208, Overseas Decoration Building, #122 Zhenhua RD., Futian, Shenzhen, China



1. Introduction

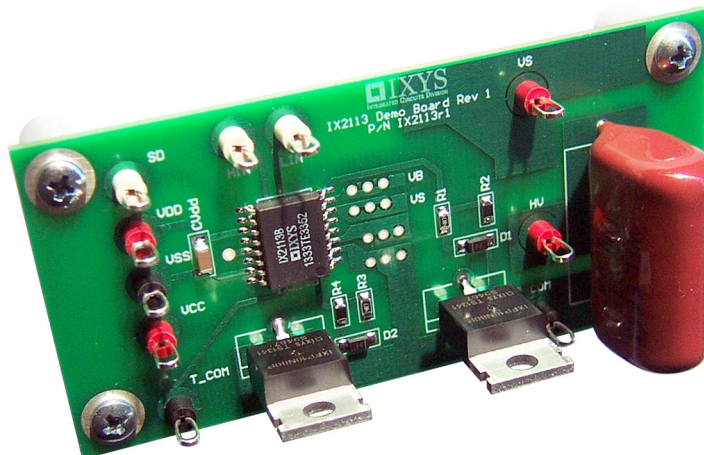

IXYS Integrated Circuits Division's IX2113 Evaluation Board contains all the necessary circuitry to demonstrate the features of a high voltage gate driver configured as a half-bridge driver. The IX2113 has independent high-side and low-side referenced output channels, both of which are capable of sourcing and sinking 2A peak current. The floating high-side channel can drive MOSFETs or IGBTs up to 600V from the common reference. In addition, when a fault or an over-current condition is detected, the shutdown (SD) pin can be used to terminate gate drive to the high-side or the low-side switch.

1.1 Features:

- Floating Channel for Bootstrap Operation up to 600V
- Outputs Capable of Sourcing and Sinking 2A Peak Current
- Gate Drive Supply Range: from 10V to 20V
- 3.3V Logic Compatibility Enables Seamless Interfacing with Microcontrollers
- Independent Under-voltage Lockout (UVLO) for High-side and Low-side Outputs
- Input Pins HIN, SD, LIN Include Schmitt Trigger for Better Noise Immunity
- High dV/dt Capability: 50V/ns
- Negative Voltage Transient Protection: -5V

Figure 1. Evaluation Board, Top View

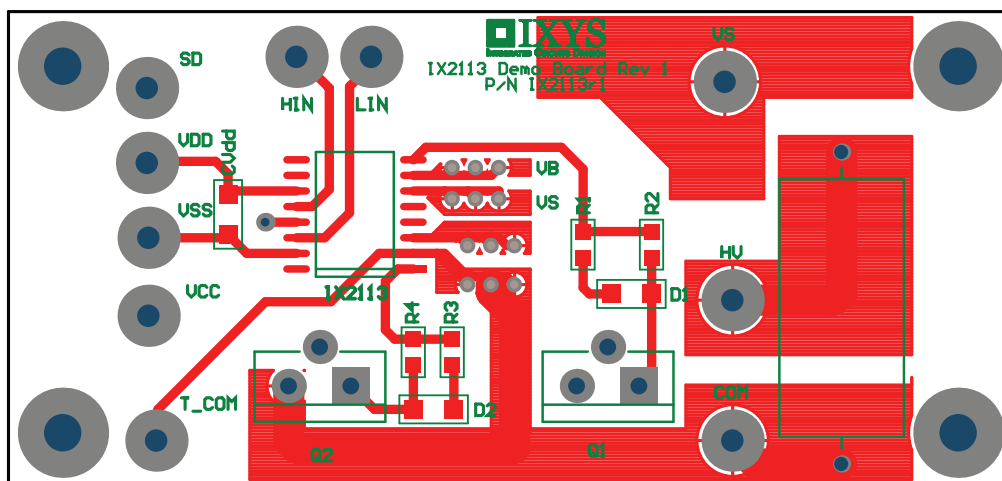
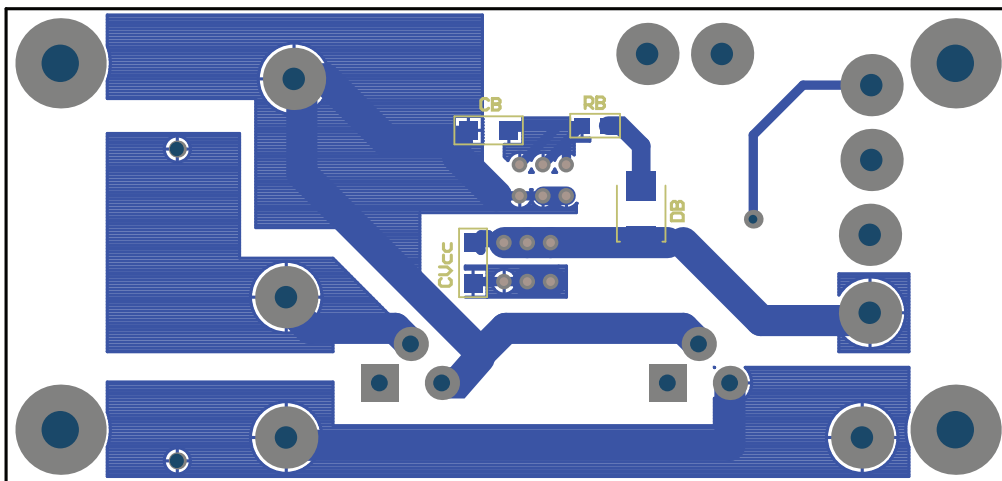

Figure 2. Evaluation Board, Bottom View



1.2 Evaluation Board Pin Descriptions

Pin Name	Description
HV	High Voltage Bus
V _S	High Side Floating Supply Return
V _{DD}	Logic Supply Voltage
V _{SS}	Logic Ground
V _{CC}	Low Side Fixed Supply Voltage
SD	Logic Input for Shutdown
HIN	Logic Input for High Side Gate Driver Output (HO)
LIN	Logic Input for Low Side Gate Driver Output (LO)
COM	Low Side Return
T_COM	Test Point Low Side Return

1.3 Evaluation Board Bill of Materials

Ref. Des.	Qty.	Description	Manufacturer	Mfr. P/N
U1	1	High and Low Side Gate Driver	IXYS IC Division	IX2113B
Q1, Q2	2	Polar HV MOSFET 800V 10A TO-220	IXYS	IXFP10N80P
R2, R4	2	RES 47 Ohm 1/8W 5% 0805 SMD	YAGEO	RC0805JR-0747RL
R1, R3, R _B	3	RES 4.7 Ohm 1/8W 5% 0805 SMD	YAGEO	RC0805JR-074R7L
D1, D2	2	DIODE Fast Recovery 30V 1A Mini2	PANASONIC	DB2230400L
D _B	1	DIODE Super Fast 600V 1A	Diodes Inc.	MURS160-13-F
CV _{CC} , CV _{DD} , C _B	3	CAP CER 0.33μF X7R 1206	TDK	C3216X7R1H334K160AA
CVBUS	1	CAP FILM 0.56μF 630VDC Radial	Panasonic	P12270

2. Functional Description

The IX2113 demo board features a very inexpensive bootstrap circuit that provides power to the high-side drive channel. It consists of resistor, R_B , super-fast-recovery diode, D_B , and capacitor, C_B .

The sequence of bootstrap charging is as follows: When the V_S high side floating supply return is pulled below V_{CC} or is pulled down to COM by the load, the C_B bootstrap capacitor begins to charge through the R_B resistor and D_B diode from the V_{CC} supply. This charge continues until V_S is pulled up to a higher voltage than V_{CC} by the external high-side power MOSFET. V_{BS} (the difference voltage between V_B and V_S) starts to float, and the bootstrap diode begins to reverse bias and block the high HV voltage.

To start the Evaluation Board, provide necessary voltages to V_{CC} , V_{DD} , and HV and refer to the IX2113 data sheet for proper operating conditions. Connect the SD pin to a microcontroller or another logic device that can pull the SD pin high when the shutdown function is desired. If the SD pin is not to be used, then it should be connected to T_COM. Provide a PWM logic input signal to LIN and HIN making sure that signals have adequate dead time in order to prevent shorting HV to COM.

The IX2113 demo board includes R2 and R4 gate resistors, and, for fast turn off, D1/R1/R2 and D2/R3/R4 diode-resistor networks.

Note: The evaluation board does not have input reverse polarity protection. Applying a negative voltage at the HV Bus Supply or V_{CC} or V_{DD} may permanently damage the components on the board. In addition, when probing the high-side output, scope probe GND has to be isolated to prevent shorting the high-side output to GND.

Figure 3. Evaluation Board Schematic

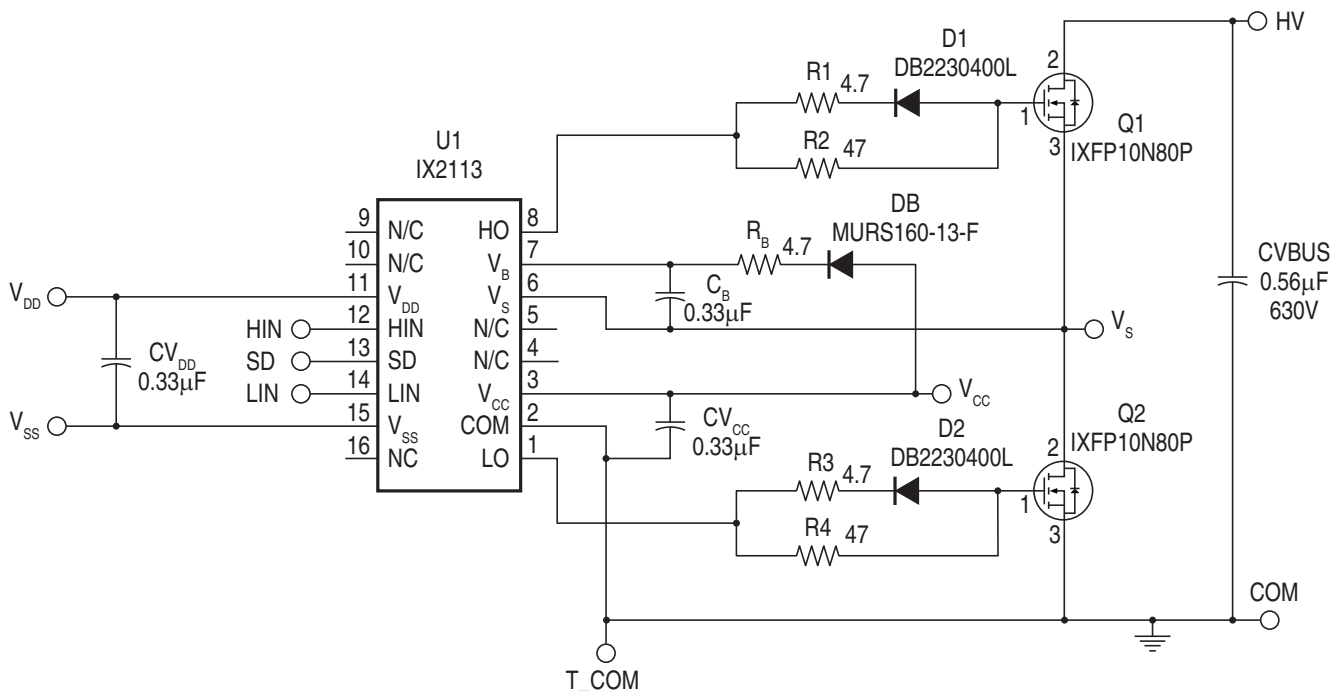

3. Operating Waveforms

Waveforms 1: CH1: Q1 gate, CH2: Q2 gate, CH3: LIN Signal, CH4: HIN Signal

This scope capture shows the rising edge of the high-side MOSFET, Q1, and the falling edge of the low-side MOSFET, Q2. LIN and HIN waveforms have 400nS dead time.

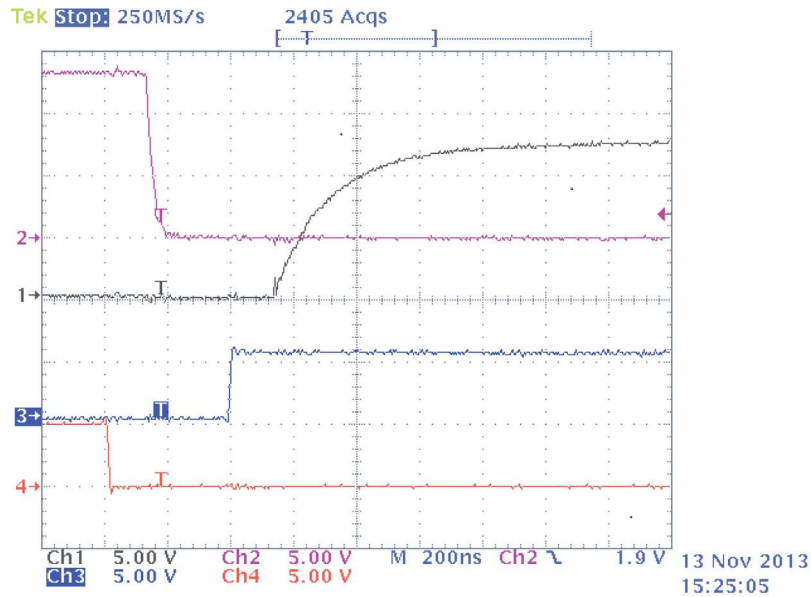

Waveforms 2: CH1: Q1 gate, CH2: Q2 gate, CH3: LIN Signal CH4: HIN Signal

This scope capture shows the falling edge of the high-side MOSFET, Q1, and the rising edge of the low-side MOSFET, Q2. LIN and HIN waveforms have 280nS dead time.

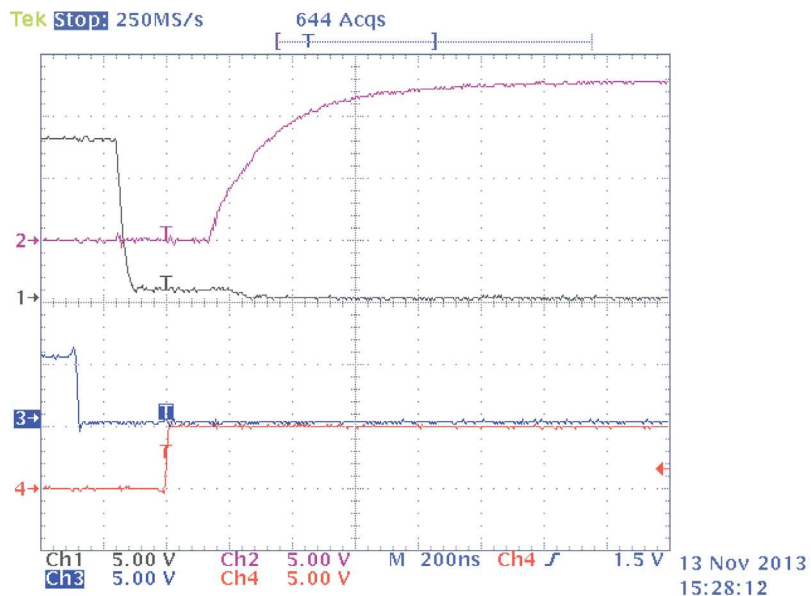

Waveforms 3: CH2: Load Current, CH3: Low Side MOSFET signal, CH4: VS High Side Floating Supply Return.

Scope capture demonstrating approximately 9W of power. A 10kΩ load resistor is attached from V_S to COM.

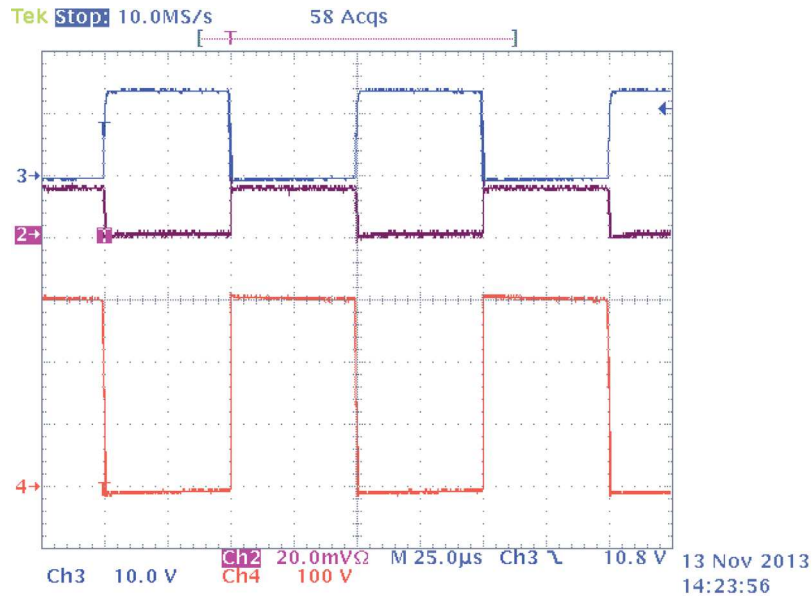

For additional information please visit www.ixysic.com

IXYS Integrated Circuits Division makes no representations or warranties with respect to the accuracy or completeness of the contents of this publication and reserves the right to make changes to specifications and product descriptions at any time without notice. Neither circuit patent licenses nor indemnity are expressed or implied. Except as set forth in IXYS Integrated Circuits Division's Standard Terms and Conditions of Sale, IXYS Integrated Circuits Division assumes no liability whatsoever, and disclaims any express or implied warranty, relating to its products including, but not limited to, the implied warranty of merchantability, fitness for a particular purpose, or infringement of any intellectual property right.

The products described in this document are not designed, intended, authorized or warranted for use as components in systems intended for surgical implant into the body, or in other applications intended to support or sustain life, or where malfunction of IXYS Integrated Circuits Division's product may result in direct physical harm, injury, or death to a person or severe property or environmental damage. IXYS Integrated Circuits Division reserves the right to discontinue or make changes to its products at any time without notice.

Specification: IX2113-UG_R01
Copyright © 2014, IXYS Integrated Circuits Division
All rights reserved. Printed in USA.
1/13/2014