



Chipsmall Limited consists of a professional team with an average of over 10 year of expertise in the distribution of electronic components. Based in Hongkong, we have already established firm and mutual-benefit business relationships with customers from,Europe,America and south Asia,supplying obsolete and hard-to-find components to meet their specific needs.

With the principle of “Quality Parts,Customers Priority,Honest Operation,and Considerate Service”,our business mainly focus on the distribution of electronic components. Line cards we deal with include Microchip,ALPS,ROHM,Xilinx,Pulse,ON,Everlight and Freescale. Main products comprise IC,Modules,Potentiometer,IC Socket,Relay,Connector.Our parts cover such applications as commercial,industrial, and automotives areas.

We are looking forward to setting up business relationship with you and hope to provide you with the best service and solution. Let us make a better world for our industry!



Contact us

Tel: +86-755-8981 8866 Fax: +86-755-8427 6832

Email & Skype: info@chipsmall.com Web: www.chipsmall.com

Address: A1208, Overseas Decoration Building, #122 Zhenhua RD., Futian, Shenzhen, China



NPN SILICON SWITCHING TRANSISTOR

Qualified per MIL-PRF-19500/395

DEVICES

2N3735 **2N3735L**
2N3737 **2N3737UB**

LEVELS
JAN
JANTX
JANTXV
JANS

ABSOLUTE MAXIMUM RATINGS ($T_C = +25^\circ\text{C}$ unless otherwise noted)

Parameters / Test Conditions	Symbol	Min.	Unit
Collector-Emitter Voltage	V_{CEO}	40	Vdc
Collector-Base Voltage	V_{CBO}	75	Vdc
Emitter-Base Voltage	V_{EBO}	5	Vdc
Collector Current	I_C	1.5	Adc
Total Power Dissipation @ $T_A = +25^\circ\text{C}$	P_T	2N3735, 2N3735L 1.0 (1)	W
		2N3737 0.5 (3)	W
		2N3737UB 0.5 (5)	W
Total Power Dissipation @ $T_C = +25^\circ\text{C}$	P_T	2N3735, 2N3735L 2.9 (2)	W
		2N3737 1.9 (4)	W
		2N3737UB N/A	W
Operating & Storage Junction Temperature Range	T_J, T_{stg}	-65 to +200	$^\circ\text{C}$

* Electrical characteristics for "L" suffix devices are identical to the "non L" corresponding devices.

- (1) Derate linearly at 5.71 mW/ $^\circ\text{C}$ above $T_A = +25^\circ\text{C}$
- (2) Derate linearly at 16.6 mW/ $^\circ\text{C}$ above $T_A = +25^\circ\text{C}$
- (3) Derate linearly at 2.86 mW/ $^\circ\text{C}$ above $T_A = +25^\circ\text{C}$
- (4) Derate linearly at 11.3 mW/ $^\circ\text{C}$ above $T_A = +25^\circ\text{C}$
- (5) Derate linearly at 3.07 mW/ $^\circ\text{C}$ above $T_A = +25^\circ\text{C}$
- (6) $T_A = +55^\circ\text{C}$ for UB on printed circuit board (PCB). PCB = FR4 .0625 inch (1.59MM) 1 - layer 1 oz Cu, horizontal, still air, pads (UB) = .034 inch (0.86 mm) x .048 inch (1.2 mm), $R_{\theta JA}$ with a defined thermal resistance condition included is measured at $P_T = 500\text{mW}$.

ELECTRICAL CHARACTERISTICS ($T_A = +25^\circ\text{C}$, unless otherwise noted)

Parameters / Test Conditions	Symbol	Min.	Max.	Unit
OFF CHARACTERISTICS				
Collector-Emitter Breakdown Voltage $I_C = 10\text{mAdc}$	$V_{(BR)CEO}$	40		Vdc
Collector-Base Cutoff Current $V_{CB} = 75\text{Vdc}$ $V_{CB} = 30\text{Vd}$	I_{CBO}		10 250	μAdc ηAdc

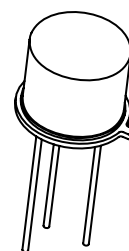

TO-5*
2N3735L

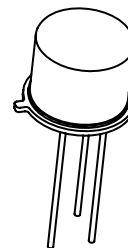

TO-39* (TO-205AD)
2N3735

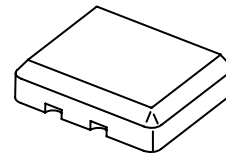

3 PIN
2N3737UB

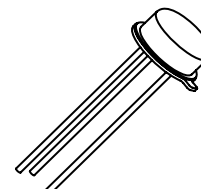

TO-46 (TO-206AB)
2N3737

ELECTRICAL CHARACTERISTICS ($T_A = +25^\circ\text{C}$, unless otherwise noted)

Parameters / Test Conditions	Symbol	Min.	Max.	Unit
OFF CHARACTERISTICS				
Collector- Emitter Cutoff Current $V_{CE} = 30\text{Vdc}$, $V_{EB} = 2.0\text{Vdc}$ $V_{CE} = 30\text{Vdc}$, $V_{EB} = 2.0\text{Vdc}$ $T_A = +150^\circ\text{C}$	I_{CEX}		200 250	nAdc μAdc
Emitter-Base Cutoff Current $V_{EB} = 5.0\text{Vdc}$ $V_{EB} = 4.0\text{Vdc}$	I_{EBO}		10 100	μAdc nAdc
ON CHARACTERISTICS ⁽¹⁾				
Forward-Current Transfer Ratio $I_C = 10\text{mAdc}$, $V_{CE} = 1.0\text{Vdc}$ $I_C = 150\text{mAdc}$, $V_{CE} = 1.0\text{Vdc}$ $I_C = 500\text{mAdc}$, $V_{CE} = 1.0\text{Vdc}$ $I_C = 1.0\text{Adc}$, $V_{CE} = 1.5\text{Vdc}$ $I_C = 1.5\text{Adc}$, $V_{CE} = 5.0\text{Vdc}$	h_{FE}	35 40 40 20 20	150 80	
Collector-Emitter Saturation Voltage $I_C = 10\text{mAdc}$, $I_B = 1.0\text{mAdc}$ $I_C = 150\text{mAdc}$, $I_B = 15.0\text{mAdc}$ $I_C = 500\text{mAdc}$, $I_B = 50.0\text{mAdc}$ $I_C = 1.0\text{Adc}$, $I_B = 100\text{mAdc}$	$V_{CE(sat)}$		0.2 0.3 0.5 0.9	Vdc
Base-Emitter Saturation Voltage $I_C = 10\text{mAdc}$, $I_B = 1.0\text{mAdc}$ $I_C = 150\text{mAdc}$, $I_B = 15.0\text{mAdc}$ $I_C = 500\text{mAdc}$, $I_B = 50.0\text{mAdc}$ $I_C = 1.0\text{Adc}$, $I_B = 100\text{mAdc}$	$V_{BE(sat)}$		0.8 1.0 1.2 1.4	Vdc

DYNAMIC CHARACTERISTICS

Forward Current Transfer Ratio $I_C = 50\text{mAdc}$, $V_{CE} = 10\text{Vdc}$, $f = 100\text{MHz}$	$ h_{fe} $	2.5	6.0	
Delay Response $I_C = 1.0\text{Adc}$, $V_{BE} = 2\text{Vdc}$, $I_{B2} = 100\text{mA}$ $V_{CC} = 30\text{Vdc}$	t_d		8	ηs
Turn-Off Time $I_C = 1.0\text{Adc}$, $I_{B1} = I_{B2} = 100\text{mAdc}$, $V_{CC} = 30\text{Vdc}$	t_{off}		60	ηs
Rise Time $I_C = 1.0\text{Adc}$, $V_{BE} = 2\text{Vdc}$, $V_{CC} = 30\text{Vdc}$	t_r		40	ηs
Output Capacitance $V_{CB} = 10\text{Vdc}$, $I_E = 0$, $100\text{kHz} \leq f \leq 1.0\text{MHz}$	C_{obo}		9	pF
Input Capacitance $V_{EB} = 0.5\text{Vdc}$, $I_C = 0$, $100\text{kHz} \leq f \leq 1.0\text{MHz}$	C_{ibo}		80	pF

(1) Pulse Test: Pulse Width = $300\mu\text{s}$, Duty Cycle $\leq 2.0\%$

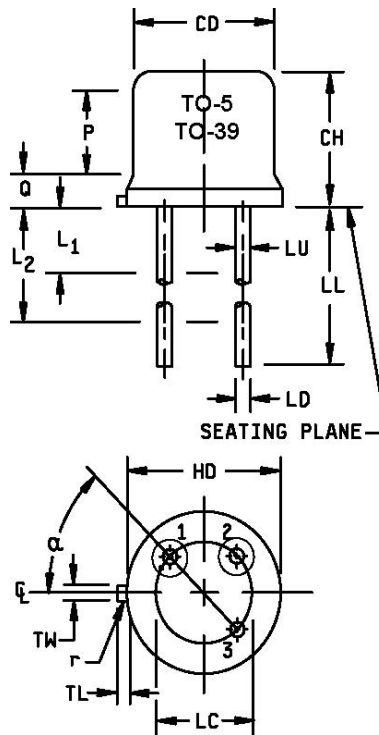
PACKAGE DIMENSIONS

2N3735 Dimensions TO-39
2N3735L Dimensions TO-5

Ltr	Dimensions				Notes
	Inches		Millimeters		
	Min	Max	Min	Max	
CD	.305	.355	7.75	9.02	
CH	.240	.260	6.10	6.60	
HD	.355	.370	9.02	9.40	
LC	.200 TP		5.08 TP		6
LD	.016	.021	0.41	0.53	7
LL	.500	.750	12.70	19.05	7
LU	.016	.019	0.41	0.48	7
L ₁		.050		1.27	7
L ₂	.250		6.35		7
P	.100		2.54		
TL	.029	.045	0.74	1.14	3
TW	.028	.034	0.71	0.86	9
Q		.040		1.02	4
r		.010		0.25	10
α	45° TP		45° TP		6

Ltr	Dimensions				Notes
	Inches		Millimeters		
	Min	Max	Min	Max	
CD	.305	.355	7.75	9.02	
CH	.240	.260	6.10	6.60	
HD	.355	.370	9.02	9.40	
LC	.200 TP		5.08 TP		6
LD	.016	.021	0.41	0.53	7
LL	1.500	1.750	38.10	44.45	7
LU	.016	.019	0.41	0.48	7
L ₁		.050		1.27	7
L ₂	.250		6.35		7
P	.100		2.54		
TL	.029	.045	0.74	1.14	3
TW	.028	.034	0.71	0.86	9
Q		.040		1.02	4
R		.010		0.25	10
α	45° TP		45° TP		6

FIGURE 1: Physical dimensions – TO-39, TO-5

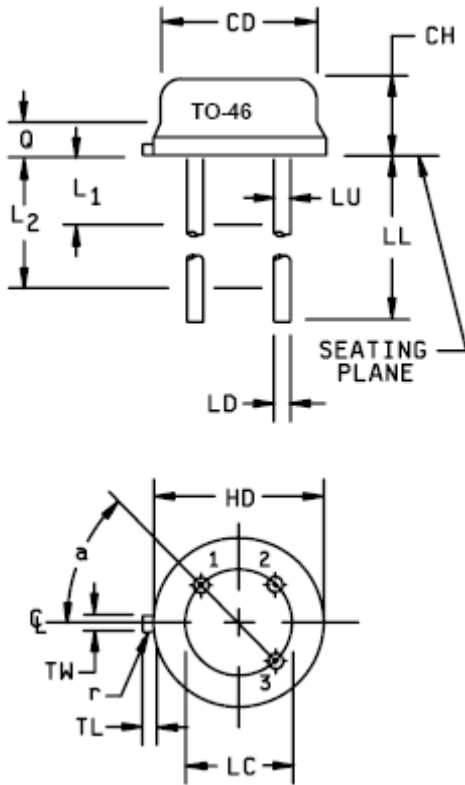
PACKAGE DIMENSIONS



Ltr	Dimensions				Notes
	Inches		Millimeters		
	Min	Max	Min	Max	
CD	.178	.195	4.52	4.95	
CH	.065	.085	1.65	2.16	
HD	.209	.230	5.31	5.84	
LC	.100 TP		2.54 TP		5
LD	.016	.021	0.41	0.53	
LL	.500	1.750	12.70	44.45	6
LU	.016	.019	0.41	0.48	6
L ₁		.050		1.27	6
L ₂	.250		6.35		6
Q		.040		1.02	3
TL	.028	.048	0.71	1.22	8
TW	.036	.046	0.91	1.17	4
r		.010		0.25	9
α	45° TP		45° TP		5

NOTES:

- 1 Dimensions are in inches.
- 2 Millimeters are given for general information only.
- 3 Symbol TL is measured from HD maximum.
- 4 Details of outline in this zone are optional.
- 5 Leads at gauge plane .054 inch (1.37 mm) +.001 inch (0.03 mm) -.000 inch (0.00 mm) below seating plane shall be within .007 inch (0.18 mm) radius of TP relative to tab. Device may be measured by direct methods or by gauge.
- 6 Symbol LU applies between L1 and L2. Dimension LD applies between L2 and LL minimum.
- 7 Lead number three is electrically connected to case.
- 8 Beyond r maximum, TW shall be held for a minimum length of .011 inch (0.28 mm).
- 9 Symbol r applied to both inside corners of tab.
- 10 In accordance with ASME Y14.5M, diameters are equivalent to ϕ x symbology.
- 11 Lead 1 is emitter, lead 2 is base, and lead 3 is collector.

FIGURE 2: Physical dimensions – TO-46 2N3737

PACKAGE DIMENSIONS

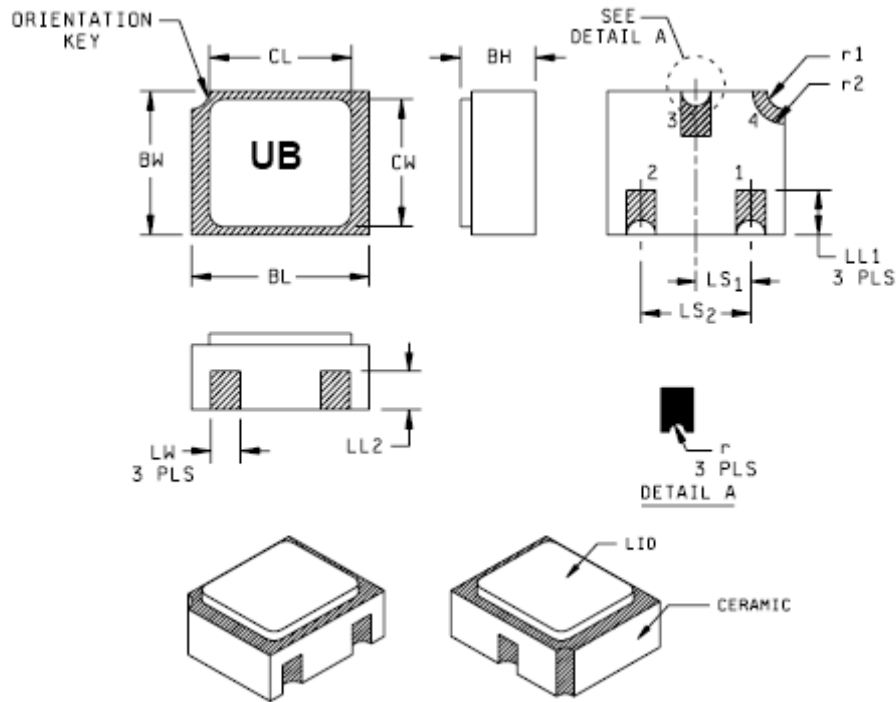

NOTES:

1. Dimensions are in inches.
2. Millimeters are given for general information only.
3. Hatched areas on package denote metalized areas.
4. Lid material: Kovar.
5. Pad 1 = Base, Pad 2 = Emitter, Pad 3 = Collector, Pad 4 = Shielding connected to the lid.
6. In accordance with ASME Y14.5m, diameters are Equivalent to ϕx symbology.

Symbol	Dimensions				Notes
	Inches		Millimeters		
	Min	Max	Min	Max	
BH	.046	.056	1.17	1.42	
BL	.115	.128	2.92	3.25	
BW	.085	.108	2.16	2.74	
CL		.128		3.25	
CW		.108		2.74	
LL1	.022	.038	0.56	0.96	
LL2	.017	.035	0.43	0.89	
LS1	.036	.040	0.91	1.02	
LS2	.071	.079	1.81	2.01	
LW	.016	.024	0.41	0.61	
r		.008		.203	
R1		.012		.305	
R2		.022		.559	