



Chipsmall Limited consists of a professional team with an average of over 10 year of expertise in the distribution of electronic components. Based in Hongkong, we have already established firm and mutual-benefit business relationships with customers from,Europe,America and south Asia,supplying obsolete and hard-to-find components to meet their specific needs.

With the principle of “Quality Parts,Customers Priority,Honest Operation,and Considerate Service”,our business mainly focus on the distribution of electronic components. Line cards we deal with include Microchip,ALPS,ROHM,Xilinx,Pulse,ON,Everlight and Freescale. Main products comprise IC,Modules,Potentiometer,IC Socket,Relay,Connector.Our parts cover such applications as commercial,industrial, and automotives areas.

We are looking forward to setting up business relationship with you and hope to provide you with the best service and solution. Let us make a better world for our industry!



## Contact us

Tel: +86-755-8981 8866 Fax: +86-755-8427 6832

Email & Skype: info@chipsmall.com Web: www.chipsmall.com

Address: A1208, Overseas Decoration Building, #122 Zhenhua RD., Futian, Shenzhen, China



## HIGH RELIABILITY POWER RECTIFIER

*Qualified per MIL-PRF-19500/260*

- Glass Passivated Die
- Glass to Metal Seal Construction
- 240 Amps Surge Rating
- VRRM to 1000 Volts

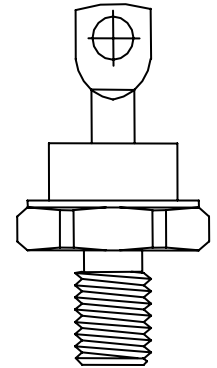
### DEVICES

<b>1N1202A</b>	<b>1N1202AR</b>	<b>1N3671A</b>	<b>1N3671AR</b>
<b>1N1204A</b>	<b>1N1204AR</b>	<b>1N3673A</b>	<b>1N3673AR</b>
<b>1N1206A</b>	<b>1N1206AR</b>		

**LEVELS**  
**JAN**  
**JANTX**  
**JANTXV**

### ABSOLUTE MAXIMUM RATINGS ( $T_C = +25^\circ\text{C}$ unless otherwise noted)

Parameters / Test Conditions	Symbol	Value	Unit
Peak Repetitive Reverse Voltage 1N1202A 1N1202AR 1N1204A 1N1204AR 1N1206A 1N1206AR 1N3671A 1N3671AR 1N3673A 1N3673AR	$V_{RWM}$	200 400 600 800 1000	V
Average Forward Current, $T_C = 150^\circ$	$I_F$	12	A
Peak Surge Forward Current @ $t_p = 8.3\text{ms}$ , half sinewave, $T_C = 200^\circ\text{C}$ , $T = 1/120\text{s}$	$I_{FSM}$	240	A
Thermal Resistance, Junction to Case	$R_{\theta jc}$	2.0	$^\circ\text{C/W}$
Operating Case Temperature Range	$T_C$	$-65^\circ\text{C}$ to $150^\circ\text{C}$	$^\circ\text{C}$
Storage Temperature Range	$T_{stg}$	$-65^\circ\text{C}$ to $200^\circ\text{C}$	$^\circ\text{C}$



**DO-203AA (DO-4)**

### ELECTRICAL CHARACTERISTICS ( $T_A = +25^\circ\text{C}$ , unless otherwise noted)

Parameters / Test Conditions	Symbol	Min.	Max.	Unit
Forward Voltage $I_F = 38\text{A}$ , $T_j = 25^\circ\text{C}^*$	$V_F$		1.35	V
Forward Voltage $I_F = 240\text{A}$ , $T_j = 25^\circ\text{C}^*$	$V_F$		2.3	V
Reverse Current $V_R = 200$ , $T_j = 25^\circ\text{C}$ $V_R = 400$ , $T_j = 25^\circ\text{C}$ $V_R = 600$ , $T_j = 25^\circ\text{C}$ $V_R = 800$ , $T_j = 25^\circ\text{C}$ $V_R = 1000$ , $T_j = 25^\circ\text{C}$	$I_R$		5	$\mu\text{A}$
Reverse Current $V_R = 200$ , $T_j = 150^\circ\text{C}$ $V_R = 400$ , $T_j = 150^\circ\text{C}$ $V_R = 600$ , $T_j = 150^\circ\text{C}$ $V_R = 800$ , $T_j = 150^\circ\text{C}$ $V_R = 1000$ , $T_j = 150^\circ\text{C}$	$I_R$		1.0	mA

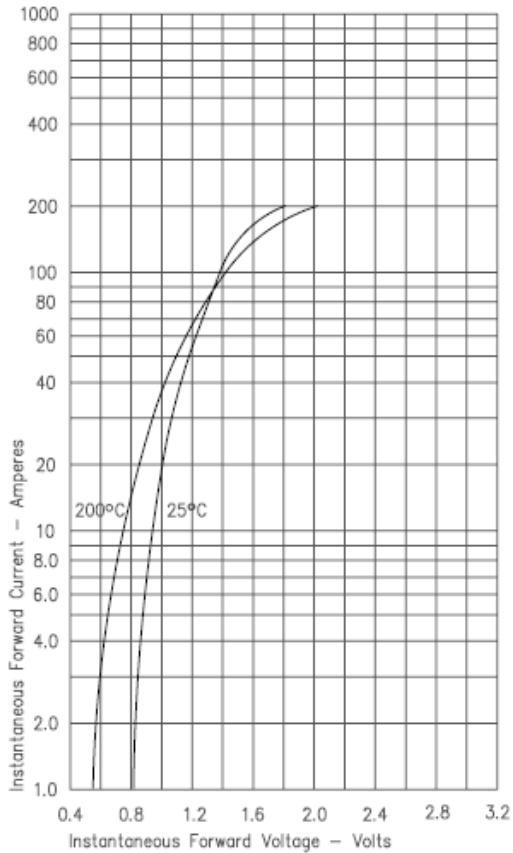
\* Pulse test: Pulse width 300  $\mu\text{sec}$ , Duty cycle 2%

**Note:**

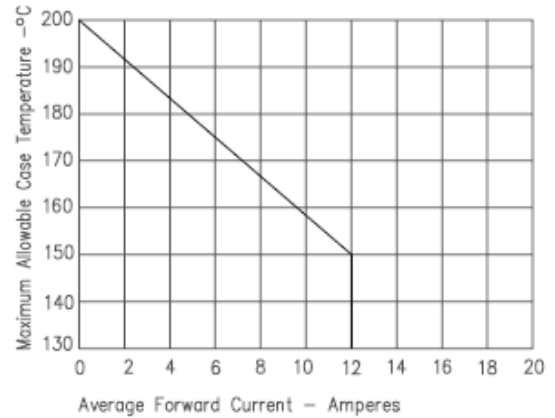
## HIGH RELIABILITY POWER RECTIFIER

### GRAPHS

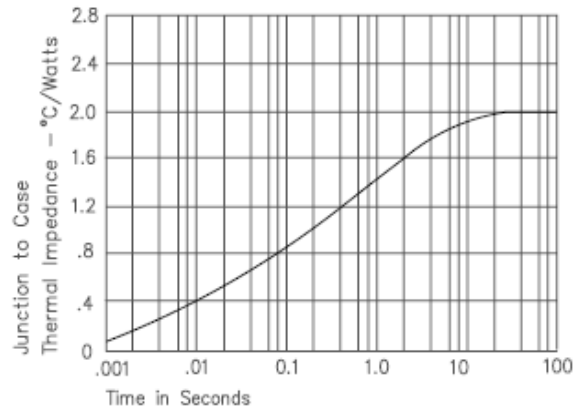
**FIGURE 1**  
**TYPICAL FORWARD CHARACTERISTICS**



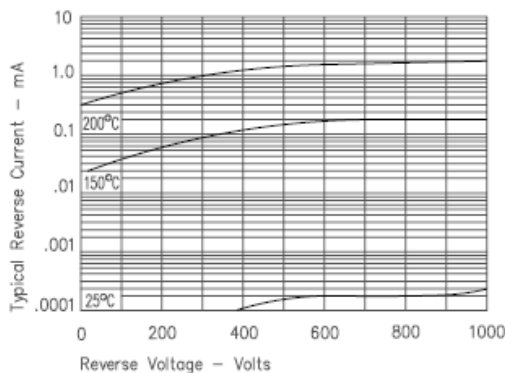
**FIGURE 3**  
**FORWARD CURRENT DERATING**



**FIGURE 5**  
**TRANSIENT THERMAL IMPEDANCE**

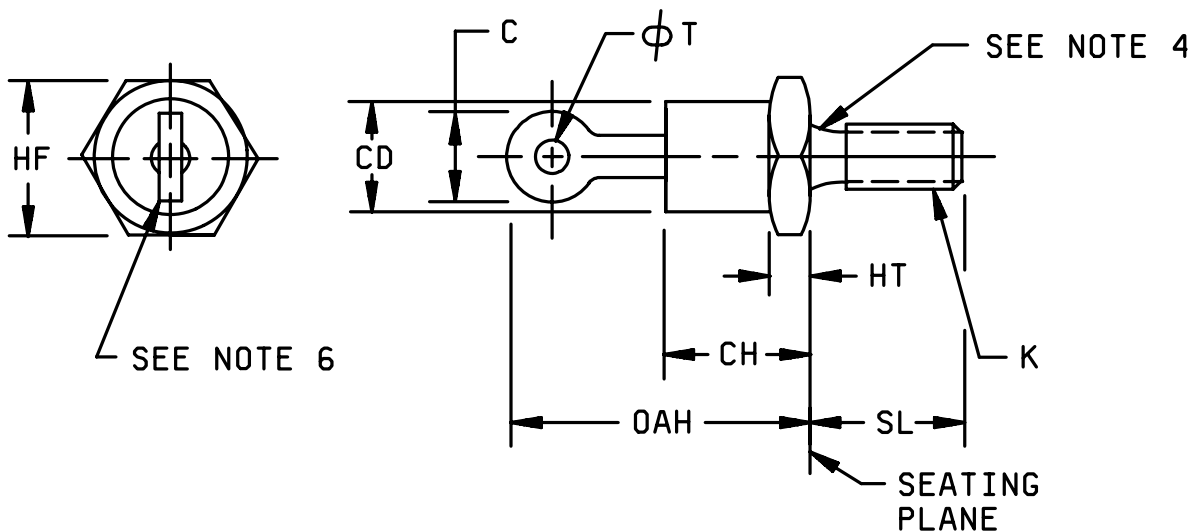


**FIGURE 2**  
**TYPICAL REVERSE CHARACTERISTICS**



## HIGH RELIABILITY POWER RECTIFIER

### PACKAGE DIMENSIONS



#### NOTES:

1. Dimensions are in inches.
2. Millimeters are given for general information only.
3. Units must not be damaged by torque of 15 inch-pounds applied to 10-32NF-2B nut assembled on thread
4. Diameter of unthreaded portion .189 inch (4.80 mm) max and .163 inch (4.14 mm) min.
5. Complete threads to extend to within 2.5 threads of seating plane.
6. Angular orientation of this terminal is undefined.
7. Max pitch diameter of plated threads shall be basic pitch diameter .169 inch (4.31 mm) reference FED-STD-H28 (Screw Thread Standards for Federal Services.)
8. The A.S.A. thread reference is 10-32UNF2A.
9. Terminal shape is unrestricted.
10. Reversed (anode to stud) units shall be marked with an R following the last digit in the type number
11. In accordance with ASME Y14.5M, diameters are equivalent to  $\phi$ x symbology.

Ltr	Dimensions				Notes
	Inches		Millimeters		
	Min	Max	Min	Max	
CH		.405		10.29	
CD		.424		10.77	
HF	.424	.437	10.77	11.10	
HT	.075	.175	1.90	4.44	
OAH		.800		20.32	
C		.250		6.35	9
$\phi$ T	.060		1.52		
SL	.422	.453	10.72	11.51	
K					3,5,7

#### Physical dimensions (DO-203AA, formerly DO-4)

1N1202A, 1N1204A, 1N1206A, 1N3671A, 1N3673A and AR versions, and 1N1124A, 1N1126A, 1N1128A, and RA versions 1N3649, 1N3650, and R versions.