



Chipsmall Limited consists of a professional team with an average of over 10 year of expertise in the distribution of electronic components. Based in Hongkong, we have already established firm and mutual-benefit business relationships with customers from,Europe,America and south Asia,supplying obsolete and hard-to-find components to meet their specific needs.

With the principle of “Quality Parts,Customers Priority,Honest Operation,and Considerate Service”,our business mainly focus on the distribution of electronic components. Line cards we deal with include Microchip,ALPS,ROHM,Xilinx,Pulse,ON,Everlight and Freescale. Main products comprise IC,Modules,Potentiometer,IC Socket,Relay,Connector.Our parts cover such applications as commercial,industrial, and automotives areas.

We are looking forward to setting up business relationship with you and hope to provide you with the best service and solution. Let us make a better world for our industry!



Contact us

Tel: +86-755-8981 8866 Fax: +86-755-8427 6832

Email & Skype: info@chipsmall.com Web: www.chipsmall.com

Address: A1208, Overseas Decoration Building, #122 Zhenhua RD., Futian, Shenzhen, China





Product Brief – JN5148-EK010

ZigBee PRO Evaluation Kit

Overview

Jennic's JN5148-EK010 ZigBee PRO evaluation kit provides a complete environment for the development of ZigBee PRO applications based on the JN5148 wireless microcontroller. The kit contains a complete package of hardware and software, including five wireless sensor nodes, an unrestricted software developer kit (SDK), and example code.

The SDK provides a complete set of development tools, software libraries and APIs (Application Programming Interfaces) for programming and controlling the on-chip peripherals of the JN5148, for configuring and managing the network and for data communication.

Out of the box, the hardware nodes are pre-programmed and demonstrate an example home sensor demo that monitors the state of sensors on the wireless nodes and presents this information on the controller node's LCD display.

Software Architecture

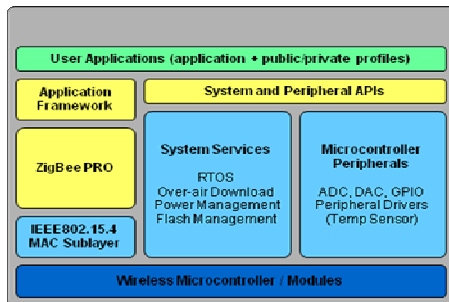

Hardware Architecture

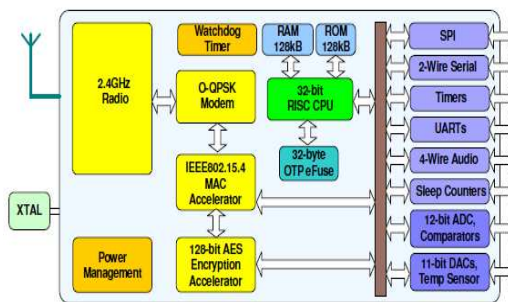

Benefits

- Complete SDK and network stack
- Stack and hardware “ZigBee Compliant Platform” certified
- Unrestricted development environment – no license fee
- Rapid application development and demonstration
- Application examples
- Profile support with increasing number of supported clusters
- Elliptic Curve Cryptography (ECC) library for Smart Energy security support available from Certicom
- Binaries for Daintree Sensor Network Analyser

Applications

- Smart energy / smart grid: load control and demand response
- Building Automation: HVAC, lighting control, access control, security, fire detection and alarm
- Industrial Automation and Control: pressure, temperature, level sensing, flow control
- Home Control: remote security and surveillance, heating control, lighting control, energy management
- Medical: patient monitoring, asset tagging

Features:



Wireless sensor nodes (5 off)

- JN5148 module
 - 2 x PCB antenna
 - 3 x uFI connected to SMA for antenna change
- Onboard temperature, light level and humidity sensors
- JN5148 IO expansion port
- 2 x USB cables
- Battery or external power supply
- 1 node with bitmapped LCD

High power modules (2 off)

- JN5148 high power module for extended range

Software development kit

- GNU-based toolchain - C compiler
- Flash programmer
- Eclipse IDE
- GNU Debugger (GDB) integrated in Eclipse
- Microcontroller and peripheral libraries

Application support

- User guides, reference manual, datasheets



Software Development

The SDK includes a complete toolchain for rapid application development and debug, including C compiler, assembler, GNU Debugger (GDB) and flash programmer. The toolchain is based upon the industry standard GNU tools running on Windows platforms. The industry standard Eclipse IDE integrates the tool chain, the RTOS and the stack configuration tool into a development environment that offers maximum customisation and collaboration between groups of developers.

Out of the box, the evaluation kit runs a home sensor demo, which measures the light, humidity and temperature levels on the wireless nodes and sends this data back to the network coordinator. In addition there are various application notes with pre-compiled binaries available as download from the Jennic support web page.

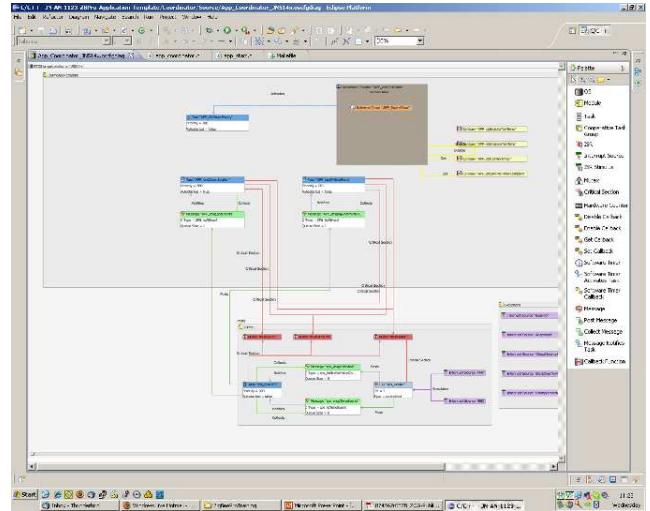

Development Hardware

Jennic's ZigBee PRO evaluation kit contains 5 battery powered wireless nodes. Each node contains temperature, humidity and light-level sensors and features Jennic's JN5148 wireless microcontroller implemented on a compact reference module.

An expansion port enables connection of additional sensors and controls to the wireless microcontroller and its peripherals. Programming of the flash memory and/or serial communications with the wireless nodes is achieved by the connection of a USB cable provided with the kit. One wireless node contains a 128x64 bitmapped LCD. For range testing and module evaluation, two high power modules with a maximum output of 20dbm are included in the kit.

ZigBee PRO Upgrade Kit (JN5148-UG010)

Customers with existing Jennic JN5139-EKxxx evaluation kits can upgrade to ZigBee PRO with the JN5148-UG010 ZigBee Upgrade Kit. The JN5148-UG010 kit contains 7 modules in total; 5 are standard power and 2 are high power modules.

Hardware Debugging

The JN5148 can support hardware debugging through the on board JTAG port and a suitable JTAG debugger (not included in the kit). For details of suitable recommended JTAG debuggers and an application note that describes how to use these with the Eclipse/GDB, please visit Jennic's website.

Daintree Network

The kit contains a fully functional 30-day evaluation copy of the Daintree Sensor Network Analyser.

Jennic Ltd
Furnival Street
Sheffield S1 4QT
United Kingdom
Tel: +44 (0) 114 281 2655
Fax: +44 (0) 114 281 2951
E-mail: info@jennic.com

www.jennic.com