



Chipsmall Limited consists of a professional team with an average of over 10 year of expertise in the distribution of electronic components. Based in Hongkong, we have already established firm and mutual-benefit business relationships with customers from,Europe,America and south Asia,supplying obsolete and hard-to-find components to meet their specific needs.

With the principle of “Quality Parts,Customers Priority,Honest Operation,and Considerate Service”,our business mainly focus on the distribution of electronic components. Line cards we deal with include Microchip,ALPS,ROHM,Xilinx,Pulse,ON,Everlight and Freescale. Main products comprise IC,Modules,Potentiometer,IC Socket,Relay,Connector.Our parts cover such applications as commercial,industrial, and automotives areas.

We are looking forward to setting up business relationship with you and hope to provide you with the best service and solution. Let us make a better world for our industry!



Contact us

Tel: +86-755-8981 8866 Fax: +86-755-8427 6832

Email & Skype: info@chipsmall.com Web: www.chipsmall.com

Address: A1208, Overseas Decoration Building, #122 Zhenhua RD., Futian, Shenzhen, China



THIS COPY IS PROVIDED ON A RESTRICTED BASIS AND IS NOT TO BE USED IN ANY WAY DETRIMENTAL TO THE INTERESTS OF PANDUIT CORP.

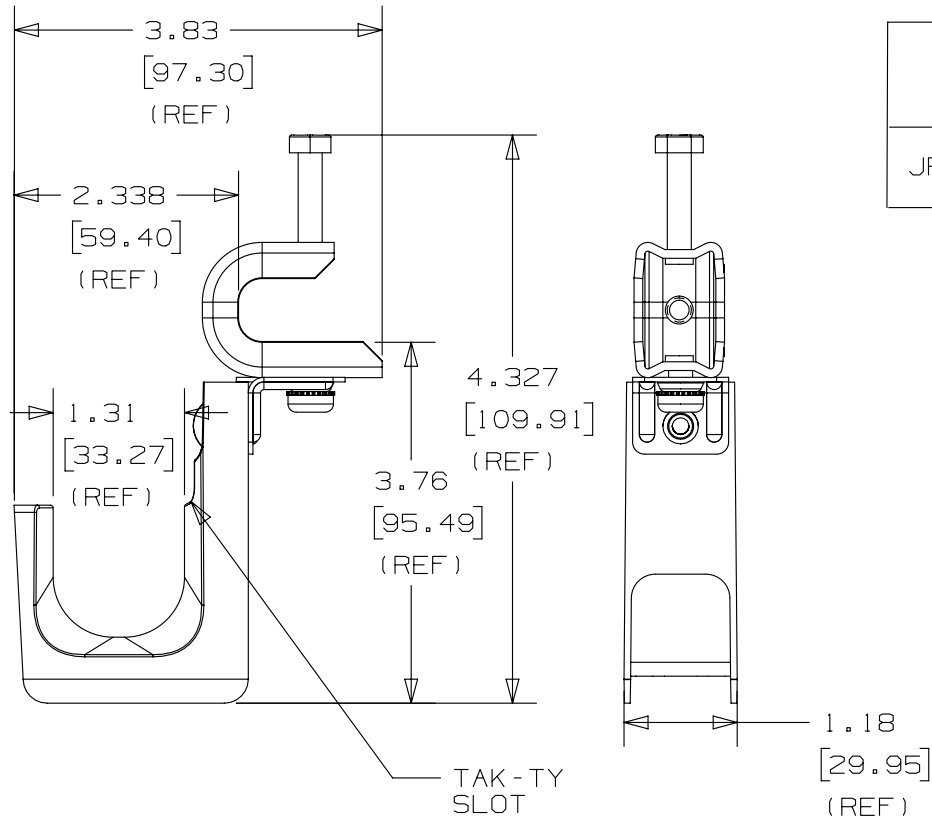

PANDUIT PART NO.	FLANGE THICKNESS	WEIGHT 10pcs lbs (g)
JP131SBC50RB_---	UP TO 0.50 [12.7]	2.07 (93.8)

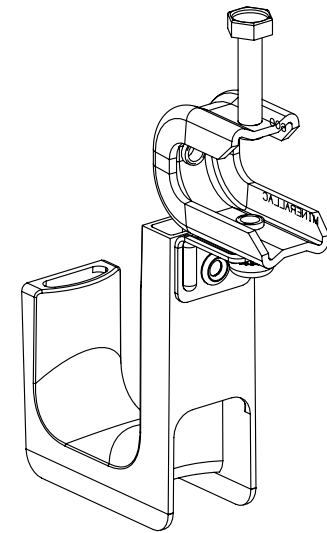

NOTES:

- SEE CURRENT PRICE SHEET FOR PART NUMBER SUFFIX DESIGNATION FOR PACKAGE SIZE AND PRODUCT COLOR.
- HOOK MATERIAL: NYLON 6/6
ANGLE BRACKET MATERIAL: PRE-GALVANIZED STEEL
RIVET MATERIAL: ALUMINUM
CLAMP MATERIAL: PLATED STEEL
BOLT/WASHER MATERIAL: ZINC PLATED STEEL
- PRODUCT IS DESIGNED TO SUPPORT A MAXIMUM OF 1 5/16" (33.34) DIAMETER BUNDLE, MAXIMUM RECOMMENDED STATIC LOAD: 20 lbs.
- PRODUCT INCORPORATES FEATURES ALLOWING USER TO RETAIN CABLE BUNDLES IN J-PRO J-HOOK WITH TAK-TY CABLE TIES UP TO 3/4" WIDE.
- PRODUCT MARKINGS:
cULus logo and statement:
"SUITABLE FOR USE IN AIR HANDLING SPACES IN ACCORDANCE WITH SECTION 300-22 (C) & (D) OF THE NATIONAL ELECTRIC CODE."
ULC logo and statement:
"IN ACCORDANCE WITH CAN/ULC S-102.2-10 IN SINGLE UNITS OR PAIRS, 4 ft (1220mm) MIN. SPACING, FSR=0, SDC=35."

TITLE									
J-PRO J-HOOK WITH 360° SCREW-ON BEAM CLAMP (JP131SBC50RB_---)									
CUSTOMER DRAWING									
ITEM REVISION NAME			121031AN/00						
DATASET FILE NAME			121031AN_DC_C11013/00B						
UNLESS OTHERWISE SPECIFIED, DIMENSIONAL TOLERANCES ARE: IN (mm)									
.x ± .1 [2.54]		.xxx ± .005 [0.127]		MATERIAL: SEE NOTE 2					
.xx ± .01 [0.25]		ANGLES ± 5°							
			THIRD ANGLE PROJECTION						
DRAWN BY		DATE	CHK	SCALE	DRAWING NUMBER:				
DBLA		1/25/2013	KLN	NONE	C11013				
REV		DATE	BY	CHK	APR	DESCRIPTION	ECN	SHT 1 OF 1	SIZE
									A

D101000A/12