



Chipsmall Limited consists of a professional team with an average of over 10 year of expertise in the distribution of electronic components. Based in Hongkong, we have already established firm and mutual-benefit business relationships with customers from,Europe,America and south Asia,supplying obsolete and hard-to-find components to meet their specific needs.

With the principle of “Quality Parts,Customers Priority,Honest Operation,and Considerate Service”,our business mainly focus on the distribution of electronic components. Line cards we deal with include Microchip,ALPS,ROHM,Xilinx,Pulse,ON,Everlight and Freescale. Main products comprise IC,Modules,Potentiometer,IC Socket,Relay,Connector.Our parts cover such applications as commercial,industrial, and automotives areas.

We are looking forward to setting up business relationship with you and hope to provide you with the best service and solution. Let us make a better world for our industry!



## Contact us

Tel: +86-755-8981 8866 Fax: +86-755-8427 6832

Email & Skype: info@chipsmall.com Web: www.chipsmall.com

Address: A1208, Overseas Decoration Building, #122 Zhenhua RD., Futian, Shenzhen, China



NOTES:

1. CONNECTOR MATERIAL:

- HOUSING:LCP BLACK UL94 V-0
- INSERTER:LCP BLACK UL94 V-0
- SHIELD:BRASS
- SHIELD PLATING:NICKEL
- CONTACT:COOPER ALLOY
- CONTACT PLATING:SELECTIVE GOLD,6 MICRO-INCHS MIN IN CONTACT AREA

2. PIN NOT ELECTRICALLY CONNECTED MAYBE OMITTED SEE ELECTRICAL DRAWING FOR OMITTED PINS

3. RJ45 CAVITIES CONFORM TO FCC RULES AND REGULATION PART 68.

4. OPERATING TEMPERATURE T=-40°C TO +85°C.

5. STORAGE TEMPERATURE T=-40°C TO +85°C.

6. COMPLIANCE TO J-STD:

- A. J-STD-020: LEVEL 1, NO MOISTURE SENSITIVE
- B. REFLOW PROFILE PEAK TEMPERATURE 245°C MAX/8 SECONDS

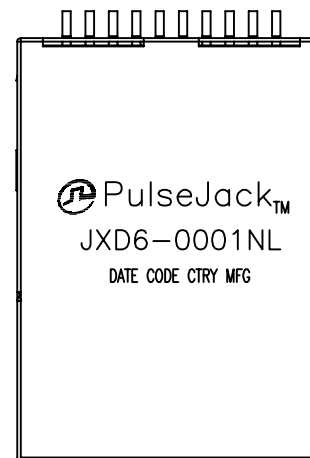

TO ORDER IN TAPE AND REEL ADD THE LETTER "T" TO THE ORDERING CODE eg. JXD6-0001NL BECOMES JXD6-0001NLT

PACKING SPECIFICATION

- REEL DIAMETER ..... 330.0mm
- TAPE WIDTH ..... 44.0mm
- POCKET PITCH ..... 32.0mm

QUANTITY PER REEL ..... 75 pcs

COMPONENT WEIGHT ..... 8.1 grams

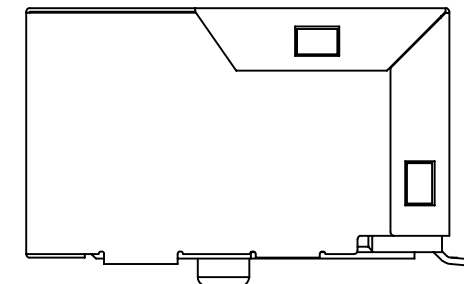
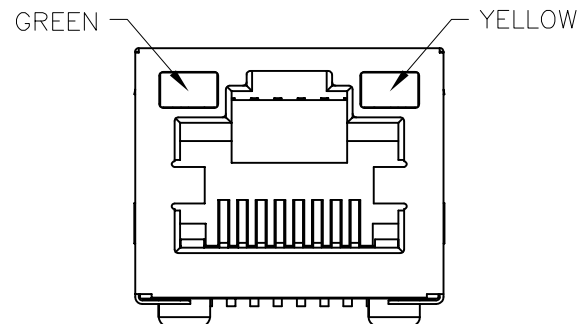

FINAL OUTLINE

© Copyright, 2016. Pulse Electronics Corp. All rights reserved. Pulse confidential & proprietary. (06/16/16)

PRODUCT DESCRIPTION	TLA DRAWING	PS DRAWING	SHEET	PART NO.	DATASHEET REV.
CONN,RJ45,1X1,100D,1:1,TY	JXD6-0001NL-X1	PS-XXXX	1 OF 4	JXD6-0001NL	A

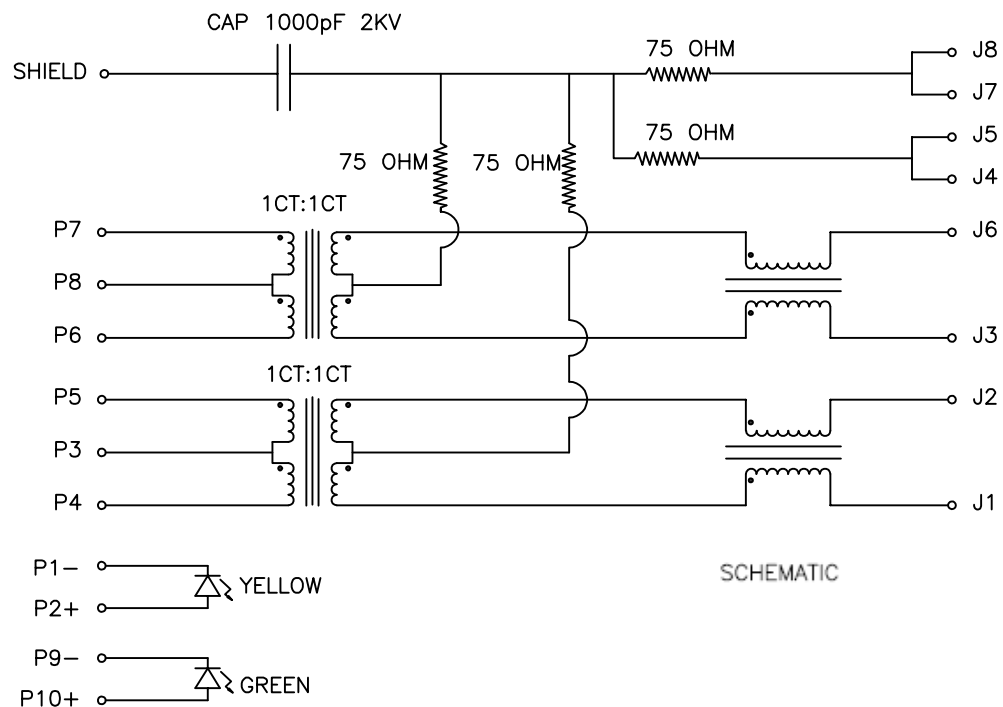

ELECTRONICAL SPECIFICATIONS:

- 1.0 TURN RATIO @100KHz: (P4~P5):(J1~J2) = 1:1±5%  
(P6~P7):(J3~J6) = 1:1±5%
- 2.0 PRIMARY INDUCTANCE: 350uH MIN @100KHz, 0.1V 8mA DC BIAS
- 3.0 DC RESISTANCE: (J1~J2):(J3~J6) 1.2 OHMS MAX
- 4.0 INSERTION LOSS: 1-100MHz -1.2dB MAX
- 5.0 RETURN LOSS: 1-30MHz -16dB MIN  
30-60MHz -12dB MIN  
60-80MHz -10dB MIN
- 6.0 CROSS TALK: 1-100MHz -30dB MIN
- 7.0 COMMON TO COMMON MODE ATTENUATION: 1-100MHz -30dB MIN
- 8.0 ISOLATION: PHY SIDE TO LINE SIDE: 2250VDC

STANDARDLED	WAVELENGTH	FORWARD CURRENT	FORWARD V (MAX)	TYP
GREEN	565nm	20 mA	2.4V	2.2V
YELLOW	590nm	20 mA	2.5V	2.1V

© Copyright, 2016. Pulse Electronics Corp. All rights reserved. Pulse confidential & proprietary. (06/16/16)

PRODUCT DESCRIPTION	TLA DRAWING	PS DRAWING	SHEET	PART NO.	DATASHEET REV.
CONN,RJ45,1X1,100D,1:1,TY	JXD6-0001NL-X1	PS-XXXX	2 OF 4	JXD6-0001NL	A

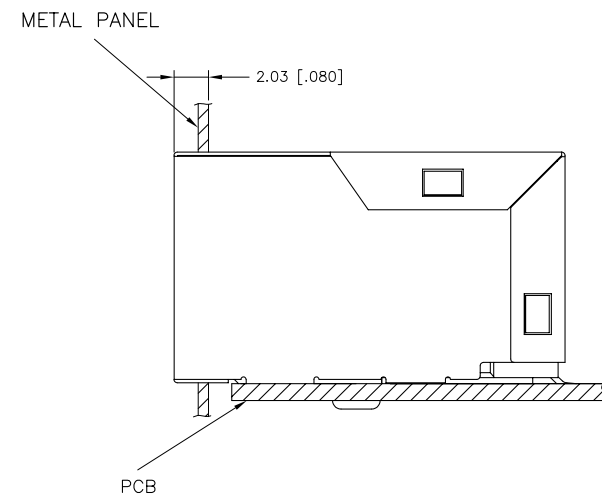
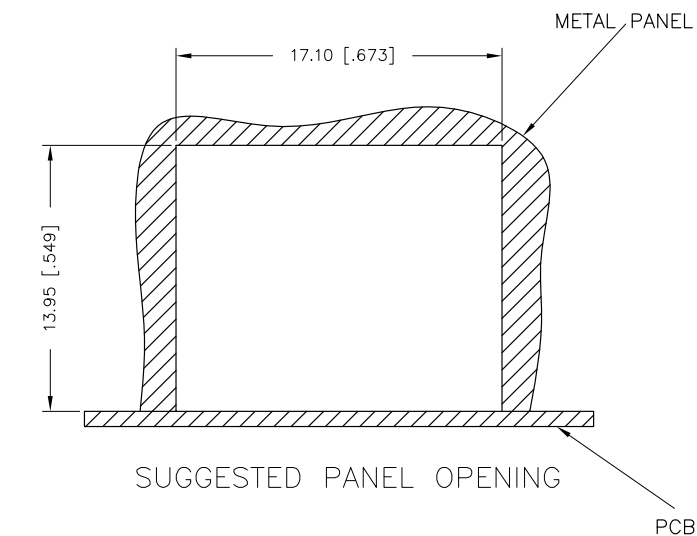
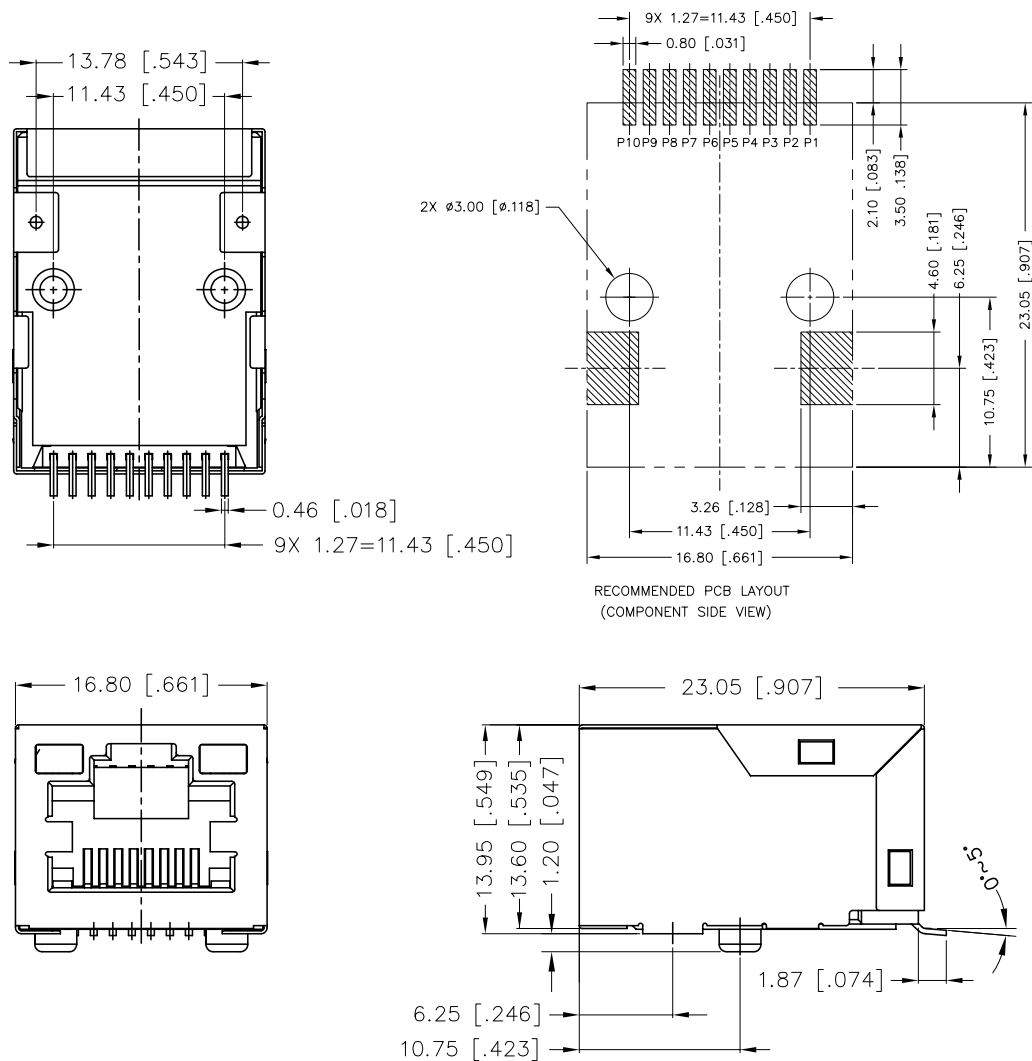

DIMENSIONS ARE IN MILLIMETERS [INCHES] WITH THE FOLLOWING TOLERANCES: [INCHES] ARE FOR REFERENCE ONLY. X.XX=  $\pm$ 0.25 [ $\pm$ .010]

TOLERANCES: [INCHES] ARE FOR REFERENCE ONLY. X.XX=  $\pm$ 0.10 [ $\pm$ .004]

© Copyright, 2016. Pulse Electronics Corp. All rights reserved. Pulse confidential & proprietary. (06/16/16)

PRODUCT DESCRIPTION	TLA DRAWING	PS DRAWING	SHEET	PART NO.	DATASHEET REV.
CONN,RJ45,1X1,100D,1:1,TY	JXD6-0001NL-X1	PS-XXXX	3 OF 4	JXD6-0001NL	A



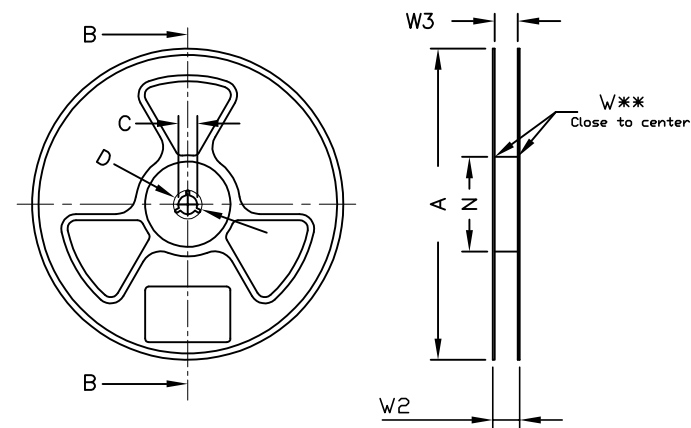
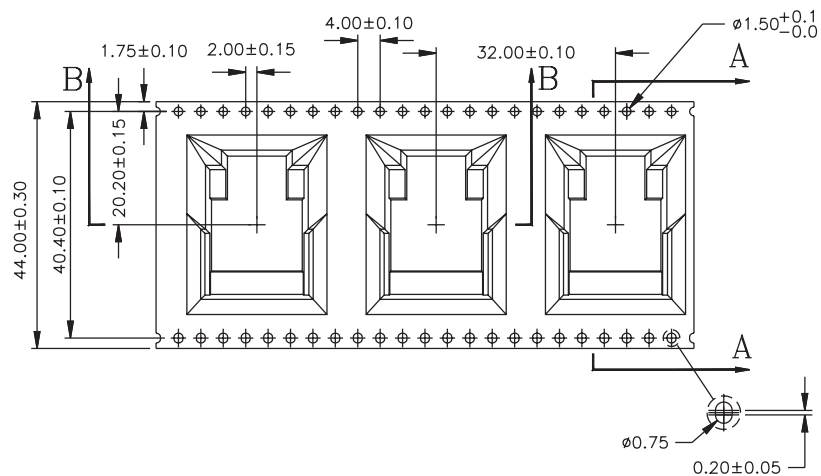

	A	B	C	D	N	W1	W2	W3	W3	
Tolerance		min.	±0.8	min.	min.	+1.5	max.	min.	max.	
Tape width	mm	330.00	1.50	13.00	20.20	100.00	16.4	50.4	44.4	46.39

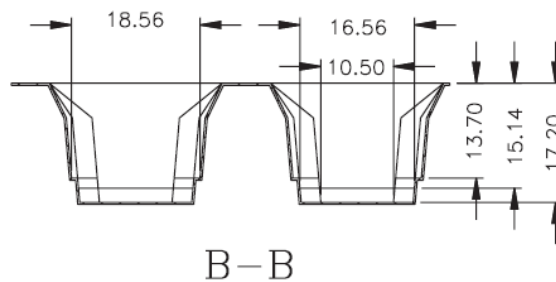
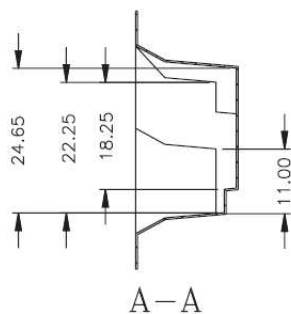

DIMENSIONS ARE IN MILLIMETERS [INCHES] WITH THE FOLLOWING TOLERANCES: [INCHES] ARE FOR REFERENCE ONLY.  
X.XX= ±0.25 [±.010]

© Copyright, 2016. Pulse Electronics Corp. All rights reserved. Pulse confidential & proprietary. (06/16/16)

PRODUCT DESCRIPTION	TLA DRAWING	PS DRAWING	SHEET	PART NO.	DATASHEET REV.
CONN,RJ45,1X1,100D,1:1,TY	JXD6-0001NL-X1	PS-XXXX	4 OF 4	JXD6-0001NL	A