



Chipsmall Limited consists of a professional team with an average of over 10 year of expertise in the distribution of electronic components. Based in Hongkong, we have already established firm and mutual-benefit business relationships with customers from,Europe,America and south Asia,supplying obsolete and hard-to-find components to meet their specific needs.

With the principle of “Quality Parts,Customers Priority,Honest Operation,and Considerate Service”,our business mainly focus on the distribution of electronic components. Line cards we deal with include Microchip,ALPS,ROHM,Xilinx,Pulse,ON,Everlight and Freescale. Main products comprise IC,Modules,Potentiometer,IC Socket,Relay,Connector.Our parts cover such applications as commercial,industrial, and automotives areas.

We are looking forward to setting up business relationship with you and hope to provide you with the best service and solution. Let us make a better world for our industry!



Contact us

Tel: +86-755-8981 8866 Fax: +86-755-8427 6832

Email & Skype: info@chipsmall.com Web: www.chipsmall.com

Address: A1208, Overseas Decoration Building, #122 Zhenhua RD., Futian, Shenzhen, China



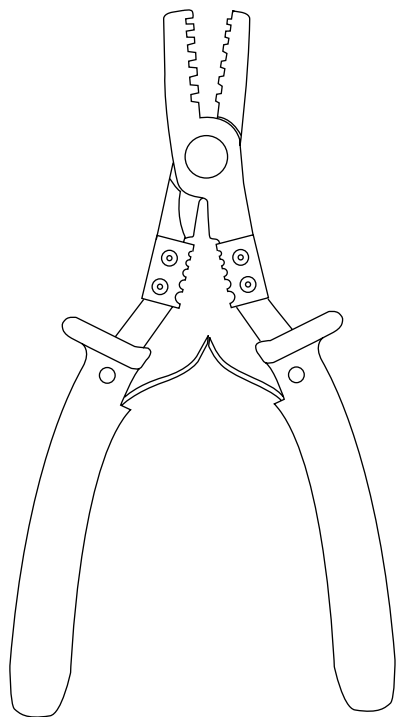

K1GL
FERRULE CRIMPER

| | |
|--|---|
| | ⚠ WARNING |
| | A person who has not read and does not understand all operating instructions is not qualified to operate this tool. Failure to read and understand safety instructions may result in injury or death. |

| | |
|--|--|
| | ⚠ WARNING |
| | Electrical Shock Hazard: This tool is not insulated. Contact with live circuits can result in severe injury or death. |

| |
|---|
| ⚠ WARNING |
| Use proper die, connector and wire combinations. Mismatched components can result in an incomplete crimp. An incomplete crimp may have high electrical resistance or may separate, resulting in a fire, severe injury or death. |

| | |
|--|---|
| | ⚠ CAUTION |
| | Keeps hands away from closing dies and other moving parts. Failure to observe this precaution can result in injury. |

Capacity

This tool is designed to strip and crimp both insulated and non-insulated wire ferrules from 26 – 14 AWG.

Crimping Instructions

- Strip the insulation from the wire to the proper length.
- Fit the ferrule over the wire. Make sure the insulating color or bell end reaches the remaining insulation.
- Open the tool.
- Insert the ferrule into the die profile: to the flare for non-insulated ferrules, or to the colored collar on insulated types.

Note: For smaller sized ferrules, close the tool until the die profile opening is only slightly larger than the ferrule, THEN insert the ferrule.

- Close the tool completely.

| |
|--|
| ⚠ CAUTION |
| Do not insert the ferrule insulation or flare into the crimping die. This can damage the tool and may result in an incomplete crimp. |

| | |
|--|---|
| | ⚠ ADVERTENCIA |
| | Las personas que no lean y comprendan todas las instrucciones operativas no deberán operar esta herramienta. El hecho de no leer y comprender las instrucciones de seguridad puede ocasionar lesiones graves o incluso la muerte. |

| | |
|--|--|
| | ⚠ ADVERTENCIA |
| | Riesgo de electrochoque: Esta herramienta no está aislada. El contacto con circuitos alimentados puede ocasionar lesiones graves o incluso la muerte. |

| |
|---|
| ⚠ PRECAUCIÓN |
| <ul style="list-style-type: none"> Mantenga los dedos y las manos fuera del punto de cierre de los troqueles y de otros puntos de contacto. Use el troquel correcto para el engarce. Use esta herramienta únicamente con las combinaciones apropiadas de alambre y casquillo. <p>La inobservancia de estas precauciones puede ocasionar lesiones o daños materiales.</p> |

Capacidad

Esta herramienta he sido diseñadas para engarzar casquillos para alambres aislados y no aislados de calibre 26 a 14.

Instrucciones de engarzado

- Quite un tramo de longitud apropiada del aislamiento del alambre.
- Coloque el casquillo sobre el alambre. Cerciórese de que la campana o el color aislante llegue al resto del aislamiento.
- Abra la herramienta.
- Inserte el casquillo en el troquel: hacia el abocinamiento, en el caso de casquillos no aislados, o hacia el collar de color, para casquillos aislados.

Nota: Si usa casquillos pequeños, cierre la herramienta hasta que la abertura del troquel sea un poco mayor que el casquillo y DESPUÉS introduzca el casquillo.

- Cierre la herramienta por completo.

| |
|---|
| ⚠ PRECAUCIÓN |
| No introduzca el aislamiento ni el abocinamiento del casquillo en el troquel de engarzado, ya que esto puede dañar la herramienta y producir un engarce incompleto. |

| | |
|--|---|
| | ⚠ AVERTISSEMENT |
| | Les personnes n'ayant pas lu et compris toutes les instructions de fonctionnement ne sont pas aptes à manipuler cet outil. Le fait de ne pas lire et comprendre les instructions de sécurité peut entraîner des blessures ou la mort. |

| | |
|--|---|
| | ⚠ AVERTISSEMENT |
| | Risque d'électrocution : Cet outil n'a pas été isolé. Tout contact avec les circuits sous tension peut entraîner de graves blessures ou la mort. |

| |
|---|
| ⚠ ATTENTION |
| <ul style="list-style-type: none"> Maintenir les doigts et les mains hors de portée des bagues de sertissage et autres points de pincement. Utiliser le profil de bague approprié pour le sertissage. Utiliser uniquement les combinaisons ferrules/calibre de câble appropriées. <p>Le fait d'ignorer ces recommandations peut entraîner des blessures ou provoquer des dégâts matériels.</p> |

Fonction

Ce outil est été conçu pour servir aussi bien des ferrules pour câbles isolés que non isolés d'un calibre compris entre 26 – 14 AWG.

Instructions de sertissage

- Dénuder le câble de son revêtement isolant sur la longueur souhaitée.
- Placer la ferrule sur le câble. S'assurer que la couleur ou l'emboîtement isolant atteint le reste du revêtement isolant.
- Ouvrir l'outil.
- Insérer la ferrule dans le profil de la bague : vers l'évasement dans le cas des ferrules sans isolation, vers le collier coloré sur les modèles avec isolation.

Remarque : Pour les ferrules aux dimensions plus réduites, serrer l'outil jusqu'à ce que l'ouverture de la bague soit légèrement supérieure à la ferrule ; ENSUITE, insérer la ferrule.

- Fermer complètement l'outil.

| |
|---|
| ⚠ ATTENTION |
| Ne pas insérer le revêtement isolant ou l'évasement de la ferrule dans la bague de compression. Ceci peut endommager l'outil et produire une sertissage incomplète. |

K1GL

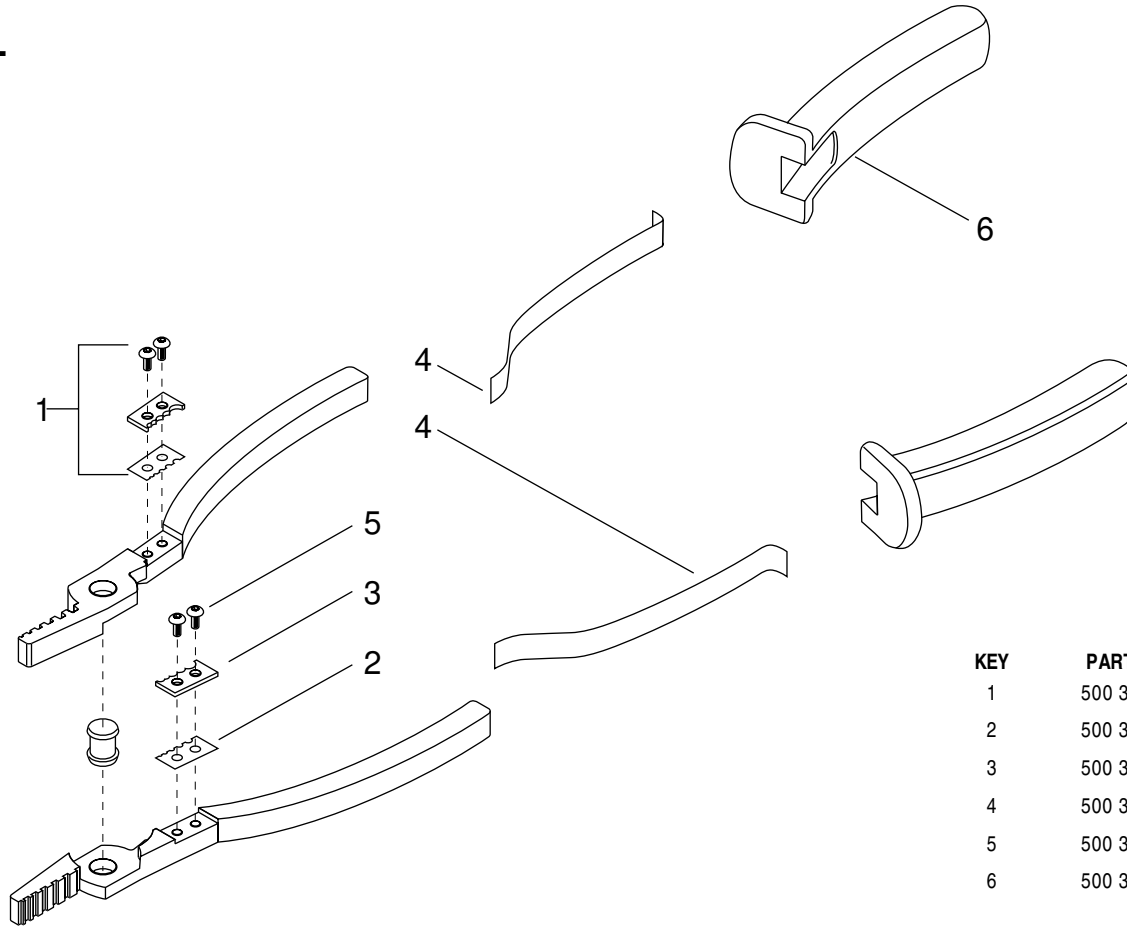

| KEY | PART NO. | DESCRIPTION | QTY. |
|-----|------------|--|------|
| 1 | 500 3287.9 | Stripper Kit (includes 2, 3 & 5) | 1 |
| 2 | 500 3291.7 | Stripper | 2 |
| 3 | 500 3292.5 | Cover Plate | 2 |
| 4 | 500 3293.3 | Spring | 2 |
| 5 | 500 3295.0 | Screw | 4 |
| 6 | 500 3296.8 | Grip | 2 |

GREENLEE **TEXTRON**

Greenlee Textron / Subsidiary of Textron Inc.

4455 Boeing Drive, Rockford, IL 61109-2988 USA

General Offices: 815/397-7070

Customer Center and Field Service: 800/435-0786

Fax (24 Hour) Customer Center: 800/451-2632 • 815/397-1865

Canada Fax (24 Hour) Customer Center: 800/524-2853