



Chipsmall Limited consists of a professional team with an average of over 10 year of expertise in the distribution of electronic components. Based in Hongkong, we have already established firm and mutual-benefit business relationships with customers from,Europe,America and south Asia,supplying obsolete and hard-to-find components to meet their specific needs.

With the principle of “Quality Parts,Customers Priority,Honest Operation,and Considerate Service”,our business mainly focus on the distribution of electronic components. Line cards we deal with include Microchip,ALPS,ROHM,Xilinx,Pulse,ON,Everlight and Freescale. Main products comprise IC,Modules,Potentiometer,IC Socket,Relay,Connector.Our parts cover such applications as commercial,industrial, and automotives areas.

We are looking forward to setting up business relationship with you and hope to provide you with the best service and solution. Let us make a better world for our industry!



Contact us

Tel: +86-755-8981 8866 Fax: +86-755-8427 6832

Email & Skype: info@chipsmall.com Web: www.chipsmall.com

Address: A1208, Overseas Decoration Building, #122 Zhenhua RD., Futian, Shenzhen, China





Is Now Part of



ON Semiconductor®

To learn more about ON Semiconductor, please visit our website at
www.onsemi.com

ON Semiconductor and the ON Semiconductor logo are trademarks of Semiconductor Components Industries, LLC dba ON Semiconductor or its subsidiaries in the United States and/or other countries. ON Semiconductor owns the rights to a number of patents, trademarks, copyrights, trade secrets, and other intellectual property. A listing of ON Semiconductor's product/patent coverage may be accessed at www.onsemi.com/site/pdf/Patent-Marking.pdf. ON Semiconductor reserves the right to make changes without further notice to any products herein. ON Semiconductor makes no warranty, representation or guarantee regarding the suitability of its products for any particular purpose, nor does ON Semiconductor assume any liability arising out of the application or use of any product or circuit, and specifically disclaims any and all liability, including without limitation special, consequential or incidental damages. Buyer is responsible for its products and applications using ON Semiconductor products, including compliance with all laws, regulations and safety requirements or standards, regardless of any support or applications information provided by ON Semiconductor. "Typical" parameters which may be provided in ON Semiconductor data sheets and/or specifications can and do vary in different applications and actual performance may vary over time. All operating parameters, including "Typicals" must be validated for each customer application by customer's technical experts. ON Semiconductor does not convey any license under its patent rights nor the rights of others. ON Semiconductor products are not designed, intended, or authorized for use as a critical component in life support systems or any FDA Class 3 medical devices or medical devices with a same or similar classification in a foreign jurisdiction or any devices intended for implantation in the human body. Should Buyer purchase or use ON Semiconductor products for any such unintended or unauthorized application, Buyer shall indemnify and hold ON Semiconductor and its officers, employees, subsidiaries, affiliates, and distributors harmless against all claims, costs, damages, and expenses, and reasonable attorney fees arising out of, directly or indirectly, any claim of personal injury or death associated with such unintended or unauthorized use, even if such claim alleges that ON Semiconductor was negligent regarding the design or manufacture of the part. ON Semiconductor is an Equal Opportunity/Affirmative Action Employer. This literature is subject to all applicable copyright laws and is not for resale in any manner.



KA7500C SMPS Controller

Features

- Internal Regulator Provides a Stable 5V Reference Supply Trimmed to $\pm 1\%$ Accuracy
- Uncommitted Output TR for 200mA Sink or Source Current
- Output Control for Push-Pull or Single-Ended Operation
- Variable Duty Cycle by Dead-Time Control (Pin 4) Complete PWM Control Circuit
- On-Chip Oscillator with Master or Slave Operation
- Internal Circuit Prohibits Double Pulse at Either Output

Description

The KA7500C is used for the control circuit of the pulse-width modulation switching regulator. The KA7500C consists of 5V reference voltage circuit, two error amplifiers, flip flop, an output control circuit, a PWM comparator, a dead-time comparator, and an oscillator.

This device can be operated in the switching frequency of 1kHz to 300kHz. The precision of voltage reference (V_{REF}) is improved up to $\pm 1\%$ with trimming. This provides a better output voltage regulation. The operating temperature range is $-25^{\circ}\text{C} \sim +85^{\circ}\text{C}$.

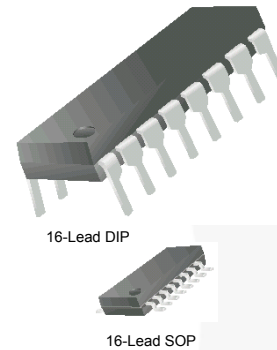

Ordering Information

Part Number	Operating Temperature Range	Eco Status	Package	Packing Method
KA7500C	-25 to +85°C	RoHS	16-Lead Dual Inline Package (DIP)	Tube
KA7500CD			16-Lead Small Outline Package (SOP)	Tube
KA7500CDTF				Tape and Reel

For Fairchild's definition of Eco Status, please visit: http://www.fairchildsemi.com/company/green/rohs_green.html.

Block Diagram

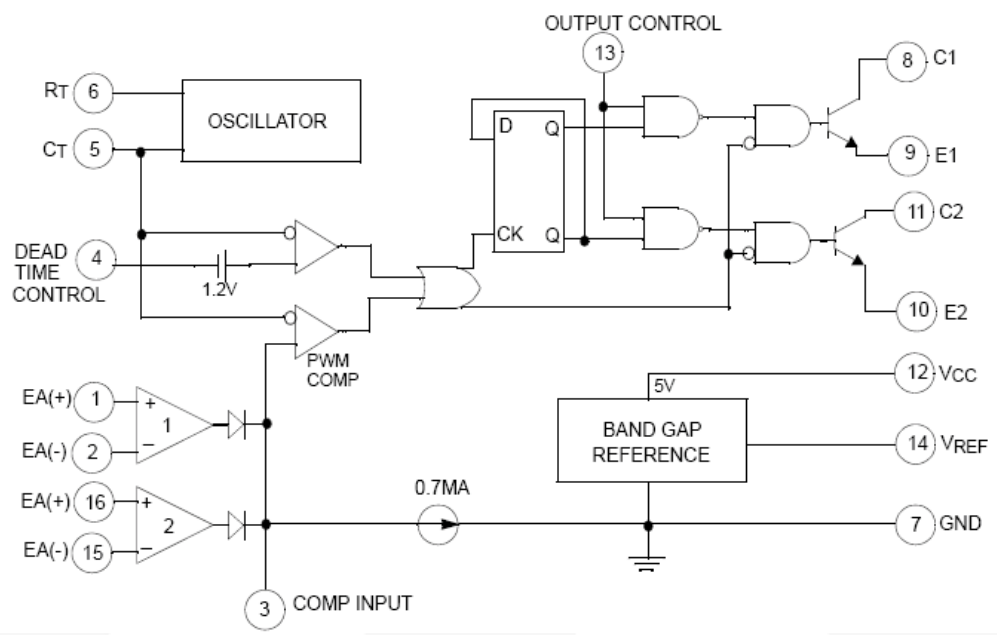

Figure 1. Block Diagram

Typical Application

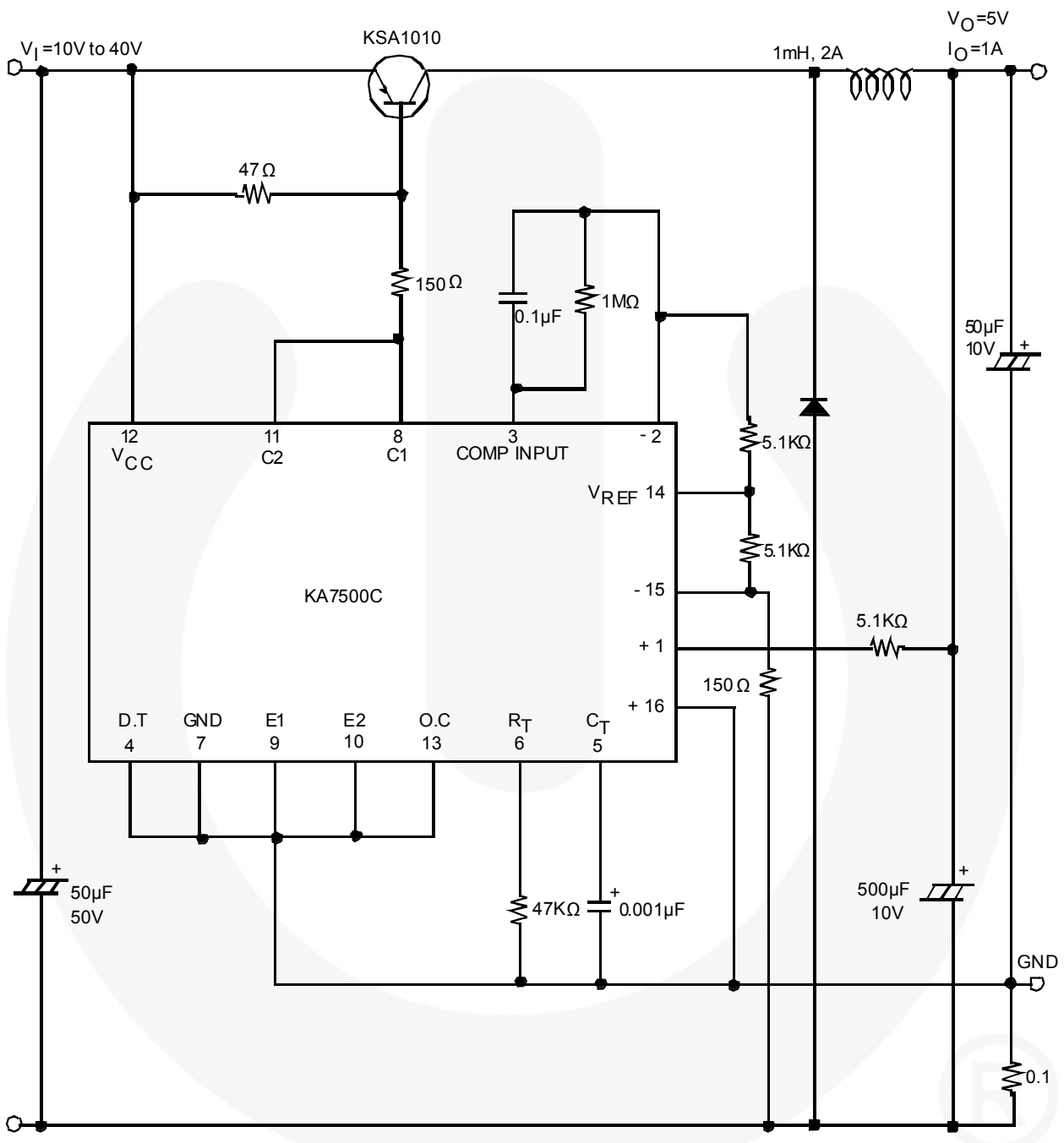

Figure 2. Pulse-Width Modulated Step-Down Converter

Absolute Maximum Ratings

Stresses exceeding the absolute maximum ratings may damage the device. The device may not function or be operable above the recommended operating conditions and stressing the parts to these levels is not recommended. In addition, extended exposure to stresses above the recommended operating conditions may affect device reliability. The absolute maximum ratings are stress ratings only.

Symbol	Parameter	Min.	Max.	Unit
V_{CC}	Supply Voltage		42	V
V_C	Collector Supply Voltage		42	V
I_O	Output Current		250	mA
V_{IN}	Amplifier Input Voltage		$V_{CC} + 0.3$	V
P_D	Power Dissipation	KA7500C	1	W
		KA7500CD	0.9	
T_{OPR}	Operation Temperature Range	-25	+85	°C
T_{STG}	Storage Temperature Rang	-65	+150	°C
T_J	Junction Temperature		+125	°C

Recommended Operating Conditions

The Recommended Operating Conditions table defines the conditions for actual device operation. Recommended operating conditions are specified to ensure optimal performance to the datasheet specifications. Fairchild does not recommend exceeding them or designing to Absolute Maximum Ratings.

Symbol	Parameter	Min.	Typ.	Max.	Unit
V_{CC}	Power Supply Voltage	7	15	40	V
V_{C1}, V_{C2}	Collector Supply Voltage		30	40	V
I_{C1}, I_{C2}	Collector Output Current (Each Transition)			200	mA
V_{IN}	Amplifier Input Voltage	0.3		$V_{CC} - 2.0$	V
I_{FB}	Current Into Feedback Terminal			0.3	mA
I_{REF}	Reference Output Terminal			10	mA
R_T	Timing Resistor	1.8	30.0	500.0	$K\Omega$
C_T	Timing Capacitor	0.0047	0.0010	10.0000	μA
f_{OSC}	Oscillator Frequency	1	40	200	kHz
V_{IN_PWM}	PWM Input Voltage (Pins 3, 4, and 13)	0.3		5.3	V

Electrical Characteristics

$V_{CC} = 20V$, $f = 10kHz$, $T_A = -25^{\circ}C$ to $+85^{\circ}C$, unless otherwise specified.

Symbol	Parameter	Conditions	Min.	Typ.	Max.	Units
Reference Section						
V_{REF}	Reference Output Voltage	$I_{REF}=1mA$, $T_A=25^{\circ}C^{(1)}$	4.95	5.00	5.05	V
		$I_{REF}=1mA$	4.90	5.00	5.10	
R_{LINE}	Line Regulation	$V_{CC}=7V$ to $40V$		2	25	mV
R_{LOAD}	Load Regulation	$I_{REF}=1mA$ to $10mA$		1	15	mV
I_{SC}	Short-Circuit Output Current	$V_{REF}=0V$	10	35	50	mA
Oscillation Frequency						
f_{OSC}	Oscillation Frequency	$C_T=0.001\mu F$, $R_T=30K\Omega$		40.0		kHz
		$C_T=0.01\mu F$, $R_T=12K\Omega$, $T_A=25^{\circ}C$	9.2	10.0	10.8	
		$C_T=0.01\mu F$, $R_T=12K\Omega$, $T_A=T_{LOW}$ to T_{HIGH}	9.0		12.0	
$\Delta f/\Delta t$	Frequency Change with Temperature	$C_T=0.01\mu F$, $R_T=12K\Omega$			2	%
Dead-Time Control Section						
I_{BIAS}	Input Bias Current	$V_{CC}=15V$, $0V \leq V_4 \leq 5.25V$		-2	-10	μA
$D_{(MAX)}$	Maximum Duty Cycle	$V_{CC}=15V$, $V_4=0V$, OC Pin= V_{REF}	45			%
V_{ITH}	Input Threshold Voltage	Zero Duty Cycle		3.0	3.3	V
		Maximum Duty Cycle	0			
Error Amplifier Section						
V_{IO}	Input Offset Voltage	$V_3=2.5V$		2	10	mV
I_{IO}	Input Offset Current	$V_3=2.5V$		25	250	mA
I_{BIAS}	Input Bias Current	$V_3=2.5V$		0.2	1.0	μA
V_{CIM}	Common Mode Input Voltage	$7V \leq V_{CC} \leq 40V$	-0.3		V_{CC}	V
G_{VO}	Open-Loop Voltage Gain	$0.5V \leq V_3 \leq 3.5V$	70	95		dB
B_W	Unit-Gain Bandwidth			650		kHz
PWM Comparator Section						
V_{ITH}	Input Threshold Voltage	Zero Duty Cycle		4.0	4.5	V
I_{SINK}	Input Sink Current	$V_3=0.7V$	-0.3	-0.7		mA
Output Section						
$V_{CE(SAT)}$	Output Saturation Voltage Common Emitter	$V_E=0V$, $I_C=200mA$		1.0	1.3	V
$V_{CC(SAT)}$	Emitter-Follower	$V_C=15V$, $I_E=-200mA$		1.5	2.5	
$I_{C(OFF)}$	Collector Off-State Current	$V_{CC}=40V$, $V_{CE}=40V$		2	100	μA
$I_{E(OFF)}$	Emitter Off-State Current	$V_{CC}=V_C=40V$, $V_E=40V$			-100	
Total Device						
I_{CC}	Supply Current	Pin6= V_{REF} , $V_{CC}=15V$		6	10	mA
Output Switching Characteristics						
t_R	Rise Time, Common Emitter, Common Collector			100	200	ns
t_F	Fall Time, Common Emitter, Common Collector			25	100	

Note:

- This is guaranteed where the marking code of the package surface is over 027.

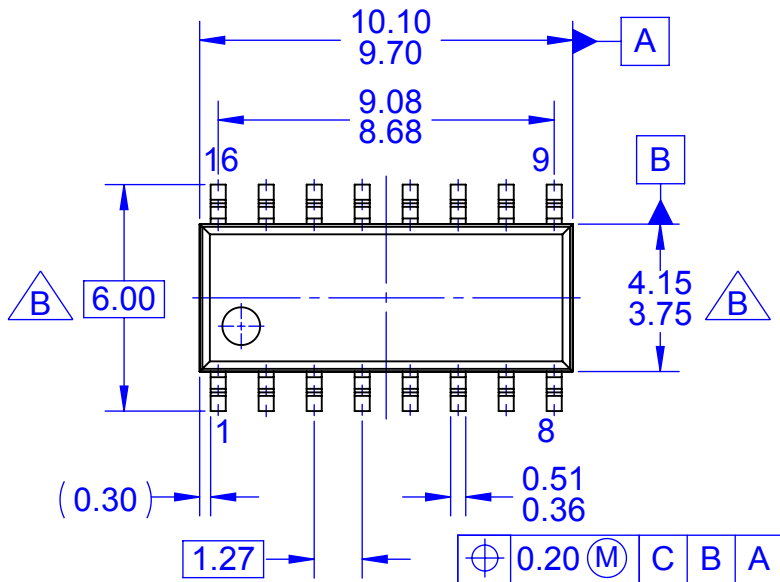

TOP VIEW

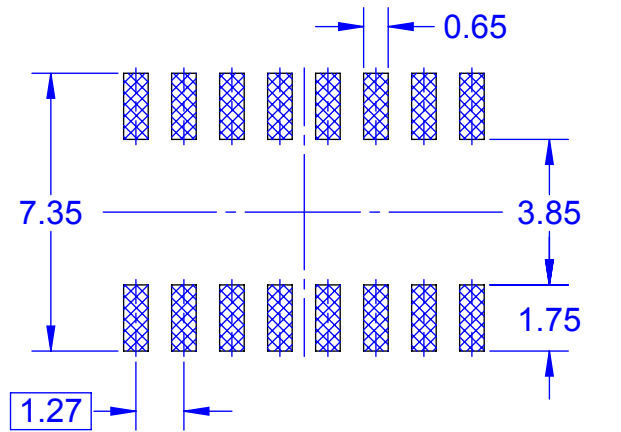

LAND PATTERN RECOMMENDATION

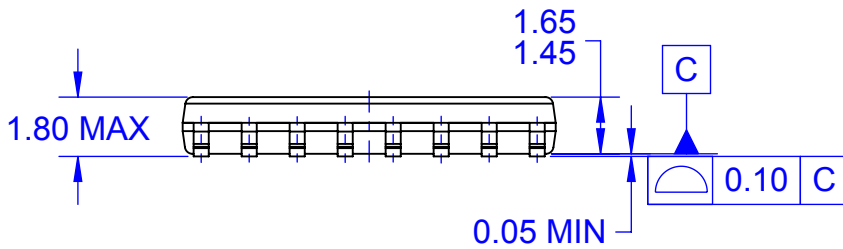

FRONT VIEW

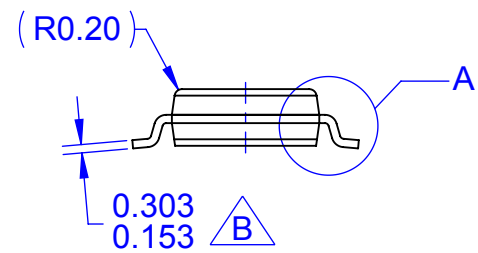

SIDE VIEW

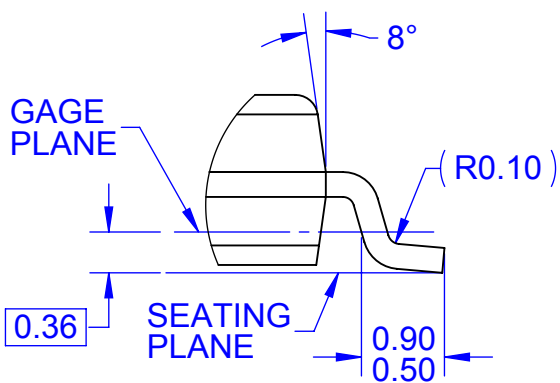

DETAIL A
SCALE 3:1

NOTES:

A. THIS DRAWING COMPLIES WITH JEDEC MS-012, EXCEPT AS NOTED

B THIS DIMENSION IS OUTSIDE JEDEC MS-012 VALUE

C. ALL DIMENSIONS ARE IN MILLIMETERS
D. DIMENSIONS ARE EXCLUSIVE OF BURRS, MOLD FLASH, AND TIE BAR EXTRUSIONS

E. LAND PATTERN STANDARD:
SOIC127P600X175-16AM

F. DRAWING FILENAME: MKT-M16Erev2



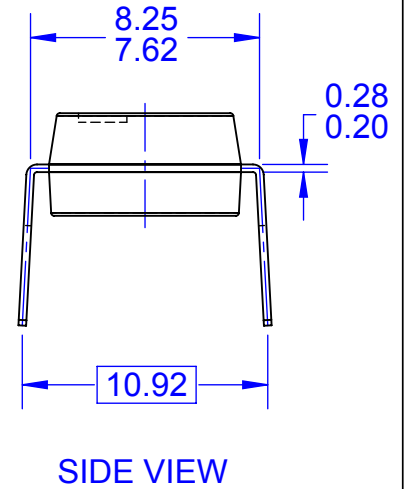
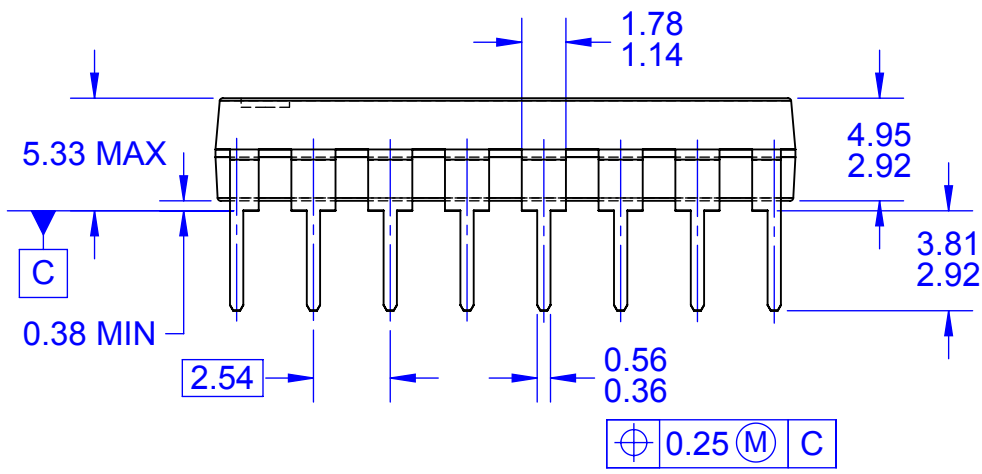
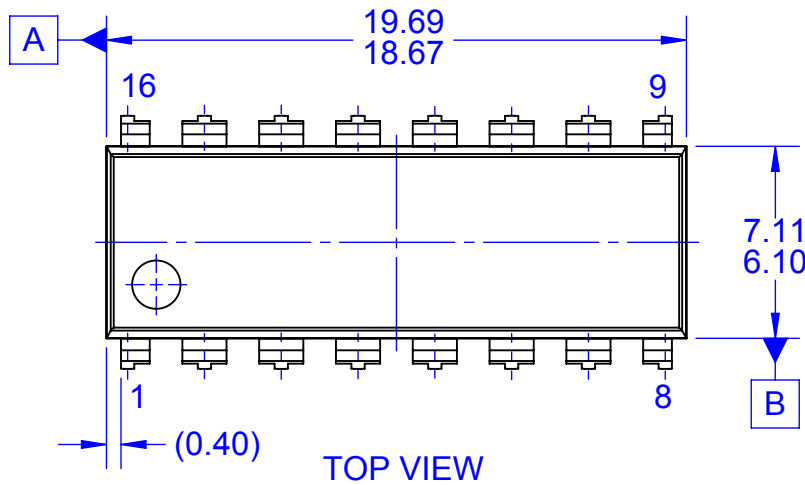

NOTES:

- A. CONFORMS TO JEDEC MS-001, VARIATION BB
- B. ALL DIMENSIONS ARE IN MILLIMETERS
- C. DIMENSIONS ARE EXCLUSIVE OF BURRS, MOLD FLASH, AND TIE BAR PROTRUSIONS
- D. DIMENSIONS AND TOLERANCES PER ASME Y14.5M-2009
- E. DRAWING FILENAME: MKT-N16Erev3



ON Semiconductor and  are trademarks of Semiconductor Components Industries, LLC dba ON Semiconductor or its subsidiaries in the United States and/or other countries. ON Semiconductor owns the rights to a number of patents, trademarks, copyrights, trade secrets, and other intellectual property. A listing of ON Semiconductor's product/patent coverage may be accessed at www.onsemi.com/site/pdf/Patent-Marking.pdf. ON Semiconductor reserves the right to make changes without further notice to any products herein. ON Semiconductor makes no warranty, representation or guarantee regarding the suitability of its products for any particular purpose, nor does ON Semiconductor assume any liability arising out of the application or use of any product or circuit, and specifically disclaims any and all liability, including without limitation special, consequential or incidental damages. Buyer is responsible for its products and applications using ON Semiconductor products, including compliance with all laws, regulations and safety requirements or standards, regardless of any support or applications information provided by ON Semiconductor. "Typical" parameters which may be provided in ON Semiconductor data sheets and/or specifications can and do vary in different applications and actual performance may vary over time. All operating parameters, including "Typicals" must be validated for each customer application by customer's technical experts. ON Semiconductor does not convey any license under its patent rights nor the rights of others. ON Semiconductor products are not designed, intended, or authorized for use as a critical component in life support systems or any FDA Class 3 medical devices or medical devices with a same or similar classification in a foreign jurisdiction or any devices intended for implantation in the human body. Should Buyer purchase or use ON Semiconductor products for any such unintended or unauthorized application, Buyer shall indemnify and hold ON Semiconductor and its officers, employees, subsidiaries, affiliates, and distributors harmless against all claims, costs, damages, and expenses, and reasonable attorney fees arising out of, directly or indirectly, any claim of personal injury or death associated with such unintended or unauthorized use, even if such claim alleges that ON Semiconductor was negligent regarding the design or manufacture of the part. ON Semiconductor is an Equal Opportunity/Affirmative Action Employer. This literature is subject to all applicable copyright laws and is not for resale in any manner.

PUBLICATION ORDERING INFORMATION

LITERATURE FULFILLMENT:

Literature Distribution Center for ON Semiconductor
19521 E. 32nd Pkwy, Aurora, Colorado 80011 USA
Phone: 303-675-2175 or 800-344-3860 Toll Free USA/Canada
Fax: 303-675-2176 or 800-344-3867 Toll Free USA/Canada
Email: orderlit@onsemi.com

N. American Technical Support: 800-282-9855 Toll Free
USA/Canada
Europe, Middle East and Africa Technical Support:
Phone: 421 33 790 2910
Japan Customer Focus Center
Phone: 81-3-5817-1050

ON Semiconductor Website: www.onsemi.com
Order Literature: <http://www.onsemi.com/orderlit>
For additional information, please contact your local
Sales Representative