



Chipsmall Limited consists of a professional team with an average of over 10 year of expertise in the distribution of electronic components. Based in Hongkong, we have already established firm and mutual-benefit business relationships with customers from,Europe,America and south Asia,supplying obsolete and hard-to-find components to meet their specific needs.

With the principle of “Quality Parts,Customers Priority,Honest Operation,and Considerate Service”,our business mainly focus on the distribution of electronic components. Line cards we deal with include Microchip,ALPS,ROHM,Xilinx,Pulse,ON,Everlight and Freescale. Main products comprise IC,Modules,Potentiometer,IC Socket,Relay,Connector.Our parts cover such applications as commercial,industrial, and automotives areas.

We are looking forward to setting up business relationship with you and hope to provide you with the best service and solution. Let us make a better world for our industry!



## Contact us

Tel: +86-755-8981 8866 Fax: +86-755-8427 6832

Email & Skype: info@chipsmall.com Web: www.chipsmall.com

Address: A1208, Overseas Decoration Building, #122 Zhenhua RD., Futian, Shenzhen, China



# KAI-4011

## 2048 (H) x 2048 (V) Interline CCD Image Sensor

### Description

The KAI-4011 Image Sensor is a high-performance 4-million pixel sensor designed for a wide range of medical, scientific and machine vision applications. The 7.4  $\mu\text{m}$  square pixels with microlenses provide high sensitivity and the large full well capacity results in high dynamic range. The two high-speed outputs and binning capabilities allow for 16–50 frames per second (fps) video rate for the progressively scanned images. The vertical overflow drain structure provides antiblooming protection and enables electronic shuttering for precise exposure control. Other features include low dark current, negligible lag and low smear.

**Table 1. GENERAL SPECIFICATIONS**

Parameter	Typical Value
Architecture	Interline CCD, Progressive Scan
Total Number of Pixels	2112 (H) $\times$ 2072 (V)
Number of Effective Pixels	2056 (H) $\times$ 2062 (V)
Number of Active Pixels	2048 (H) $\times$ 2048 (V)
Pixel Size	7.4 $\mu\text{m}$ (H) $\times$ 7.4 $\mu\text{m}$ (V)
Active Image Size	15.15 mm (H) $\times$ 15.15 mm (V), 21.43 mm (Diagonal),
Aspect Ratio	1:1
Number of Outputs	1 or 2
Saturation Signal	40,000 $e^-$
Peak Quantum Efficiency –ABA –CBA (BGR)	55% 45%, 42%, 35%
Total System Noise 40 MHz 20 MHz	40 $e^-$ 23 $e^-$
Dark Current	< 0.5 nA/cm <sup>2</sup>
Dark Current Doubling Temperature	7°C
Dynamic Range	60 dB
Charge Transfer Efficiency	> 0.99999
Blooming Suppression	300X
Smear	80 dB
Image Lag	< 10 $e^-$
Maximum Data Rate	40 MHz
Package	34-pin, cerDIP
Cover Glass	AR Coated, 2 Sides

NOTE: All parameters above are specified at T = 40°C.



**ON Semiconductor®**

[www.onsemi.com](http://www.onsemi.com)



**Figure 1. KAI-4011 Interline CCD Image Sensor**

### Features

- High Resolution
- High Sensitivity
- High Dynamic Range
- Low Noise Architecture
- High Frame Rate
- Binning Capability for Higher Frame Rate
- Electronic Shutter

### Applications

- Machine Vision

### ORDERING INFORMATION

See detailed ordering and shipping information on page 2 of this data sheet.

# KAI-4011

## ORDERING INFORMATION

**Table 2. ORDERING INFORMATION – KAI-4011 IMAGE SENSOR**

Part Number	Description	Marking Code
KAI-4011-AAA-CR-BA	Monochrome, No Microlens, CERDIP Package (Sidebrazed), Taped Clear Cover Glass with AR Coating (2 Sides), Standard Grade	KAI-4011 Serial Number
KAI-4011-AAA-CR-AE	Monochrome, No Microlens, CERDIP Package (Sidebrazed), Taped Clear Cover Glass with AR Coating (2 Sides), Engineering Sample	
KAI-4011-ABA-CD-BA	Monochrome, Telecentric Microlens, CERDIP Package (Sidebrazed), Clear Cover Glass with AR Coating (Both Sides), Standard Grade	KAI-4011M Serial Number
KAI-4011-ABA-CD-AE	Monochrome, Telecentric Microlens, CERDIP Package (Sidebrazed), Clear Cover Glass with AR Coating (Both Sides), Engineering Sample	
KAI-4011-ABA-CR-BA	Monochrome, Telecentric Microlens, CERDIP Package (Sidebrazed), Taped Clear Cover Glass with AR Coating (2 Sides), Standard Grade	
KAI-4011-ABA-CR-AE	Monochrome, Telecentric Microlens, CERDIP Package (Sidebrazed), Taped Clear Cover Glass with AR Coating (2 Sides), Engineering Sample	
KAI-4011-CBA-CD-BA*	Color (Bayer RGB), Telecentric Microlens, CERDIP Package (Sidebrazed), Clear Cover Glass with AR Coating (Both Sides), Standard Grade	KAI-4011CM Serial Number
KAI-4011-CBA-CD-AE*	Color (Bayer RGB), Telecentric Microlens, CERDIP Package (Sidebrazed), Clear Cover Glass with AR Coating (Both Sides), Engineering Sample	

\*Not recommended for new designs.

**Table 3. ORDERING INFORMATION – EVALUATION SUPPORT**

Part Number	Description
KAI-4011-10-40-A-EVK	Evaluation Board, (Complete Kit)
KAI-4021-10-40-A-EVK	Evaluation Board, (Complete Kit)

See the ON Semiconductor *Device Nomenclature* document (TND310/D) for a full description of the naming convention used for image sensors. For reference documentation, including information on evaluation kits, please visit our web site at [www.onsemi.com](http://www.onsemi.com).



DEVICE DESCRIPTION

Architecture

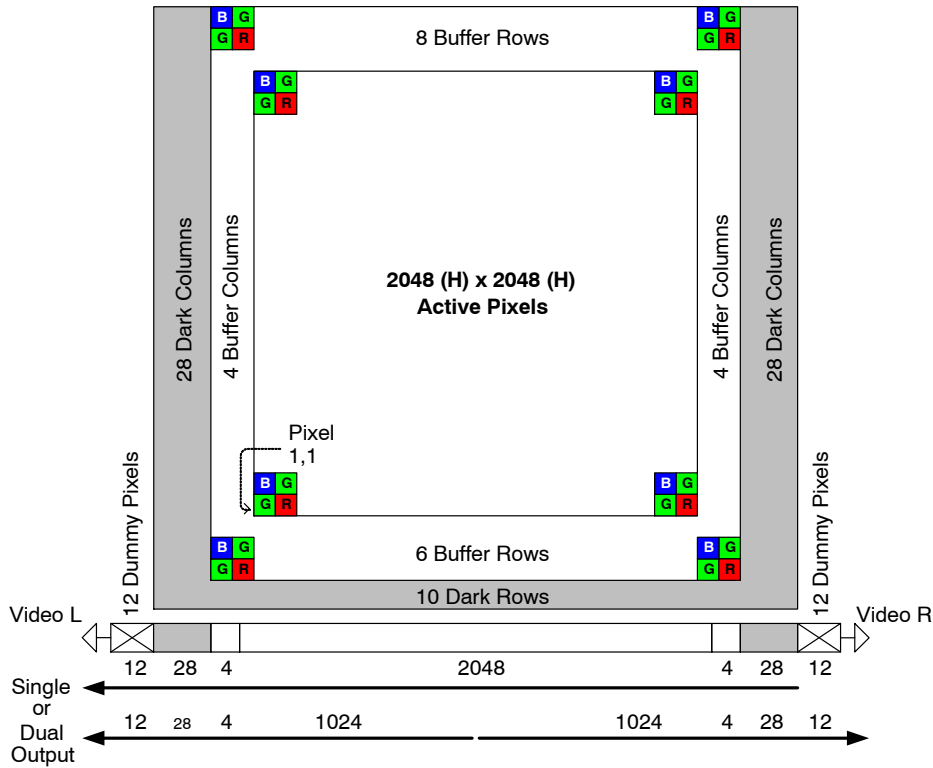

Figure 2. Sensor Architecture

There are 10 light shielded rows followed 2062 photoactive rows. The first 6 and the last 8 photoactive rows are buffer rows giving a total of 2048 lines of image data.

In the single output mode all pixels are clocked out of the Video L output in the lower left corner of the sensor. The first 12 empty pixels of each line do not receive charge from the vertical shift register. The next 28 pixels receive charge from the left light-shielded edge followed by 2056 photo-sensitive pixels and finally 28 more light shielded pixels from the right edge of the sensor. The first and last 4 photosensitive pixels are buffer pixels giving a total of 2048 pixels of image data.

In the dual output mode the clocking of the right half of the horizontal CCD is reversed. The left half of the image is clocked out Video L and the right half of the image is clocked

out Video R. Each row consists of 12 empty pixels followed by 28 light shielded pixels followed by 1028 photosensitive pixels. When reconstructing the image, data from Video R will have to be reversed in a line buffer and appended to the Video L data.

There are no dark reference rows at the top and 10 dark rows at the bottom of the image sensor. The 10 dark rows are not entirely dark and so should not be used for a dark reference level. Use the 28 dark columns on the left or right side of the image sensor as a dark reference.

Of the 28 dark columns, the first and last dark columns should not be used for determining the zero signal level. Some light does leak into the first and last dark columns. Only use the center 26 columns of the 28 column dark reference.

Pixel

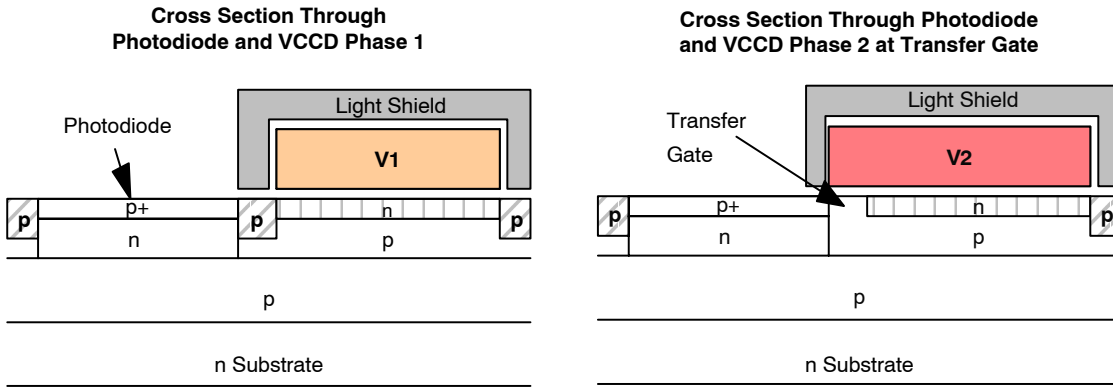
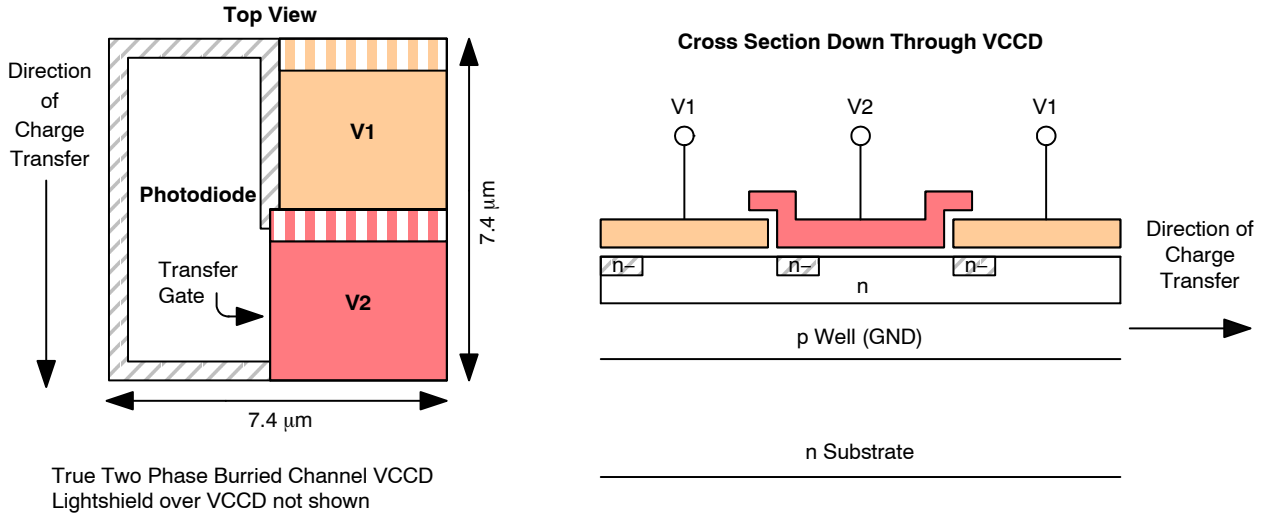

NOTE: Drawings not scale.

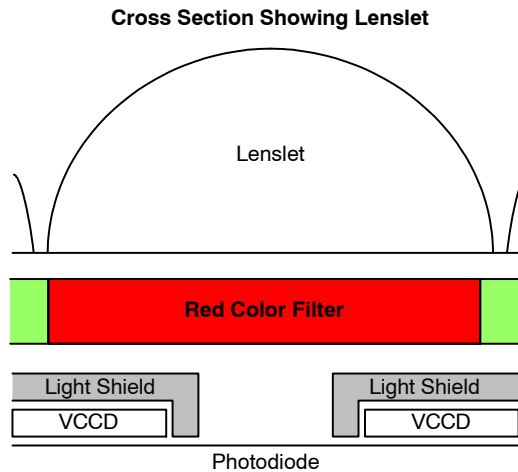

Figure 3. Pixel Architecture

An electronic representation of an image is formed when incident photons falling on the sensor plane create electron-hole pairs within the individual silicon photodiodes. These photoelectrons are collected locally by the formation of potential wells at each photosite. Below photodiode saturation, the number of photoelectrons

collected at each pixel is linearly dependent upon light level and exposure time and non-linearly dependent on wavelength. When the photodiodes charge capacity is reached, excess electrons are discharged into the substrate to prevent blooming.

Vertical to Horizontal Transfer

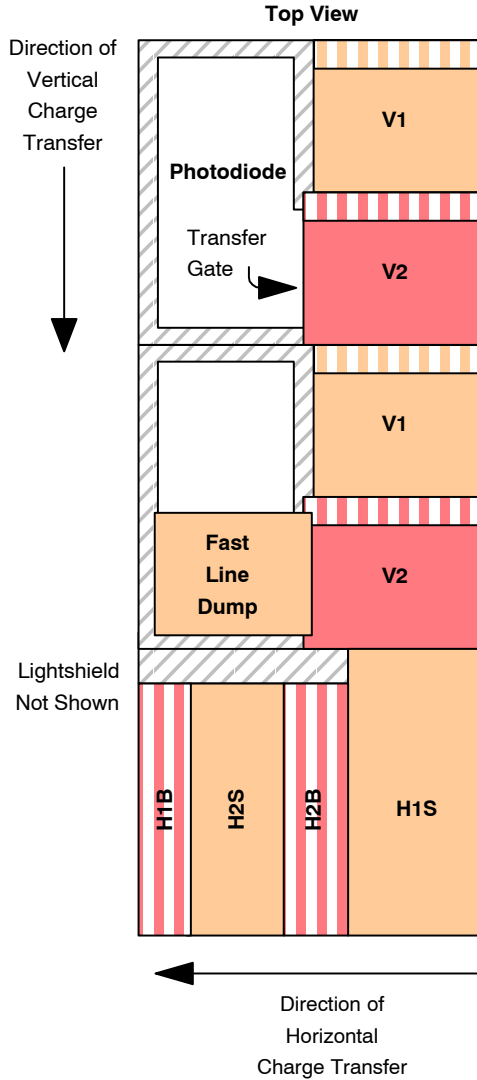

Figure 4. Vertical to Horizontal Transfer Architecture

When the V1 and V2 timing inputs are pulsed, charge in every pixel of the VCCD is shifted one row towards the HCCD. The last row next to the HCCD is shifted into the HCCD. When the VCCD is shifted, the timing signals to the HCCD must be stopped. H1 must be stopped in the high state and H2 must be stopped in the low state. The HCCD clocking may begin  $T_{HD}$   $\mu$ s after the falling edge of the V1 and V2 pulse.

Charge is transferred from the last vertical CCD phase into the H1S horizontal CCD phase. Refer to Figure 36 for an example of timing that accomplishes the vertical to horizontal transfer of charge.

If the fast line dump is held at the high level (FDH) during a vertical to horizontal transfer, then the entire line is removed and not transferred into the horizontal register.

Horizontal Register to Floating Diffusion

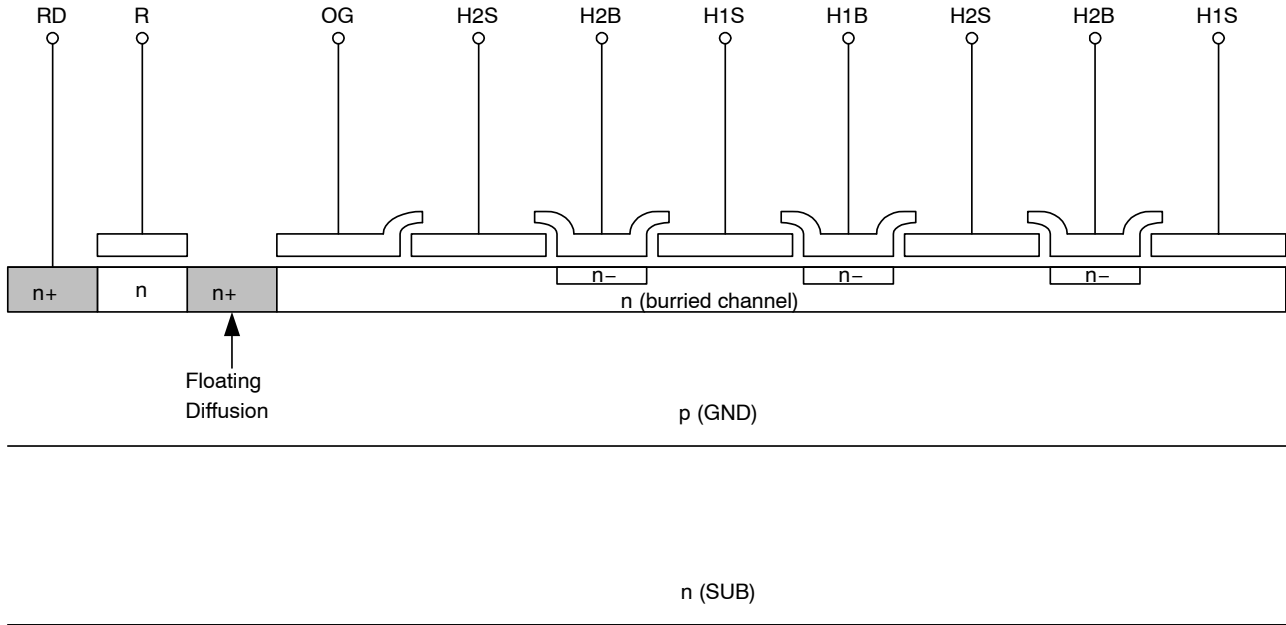

Figure 5. Horizontal Register to Floating Diffusion Architecture

The HCCD has a total of 2124 pixels. The 2112 vertical shift registers (columns) are shifted into the center 2112 pixels of the HCCD. There are 12 pixels at both ends of the HCCD, which receive no charge from a vertical shift register. The first 12 clock cycles of the HCCD will be empty pixels (containing no electrons). The next 28 clock cycles will contain only electrons generated by dark current in the VCCD and photodiodes. The next 2056 clock cycles will contain photo-electrons (image data). Finally, the last 28 clock cycles will contain only electrons generated by dark current in the VCCD and photodiodes. Of the 28 dark columns, the first and last dark columns should not be used for determining the zero signal level. Some light does leak into the first and last dark columns. Only use the center 26 columns of the 28 column dark reference.

When the HCCD is shifting valid image data, the timing inputs to the electronic shutter (SUB), VCCD (V1, V2), and fast line dump (FD) should not be pulsed. This prevents unwanted noise from being introduced. The HCCD is a type of charge coupled device known as a pseudo-two phase CCD. This type of CCD has the ability to shift charge in two directions. This allows the entire image to be shifted out to the video L output, or to the video R output (left/right image reversal). The HCCD is split into two equal halves of 1068 pixels each. When operating the sensor in single output mode the two halves of the HCCD are shifted in the same direction. When operating the sensor in dual output mode the two halves of the HCCD are shifted in opposite directions. The direction of charge transfer in each half is controlled by the H1BL, H2BL, H1BR, and H2BR timing inputs.

## Horizontal Register Split

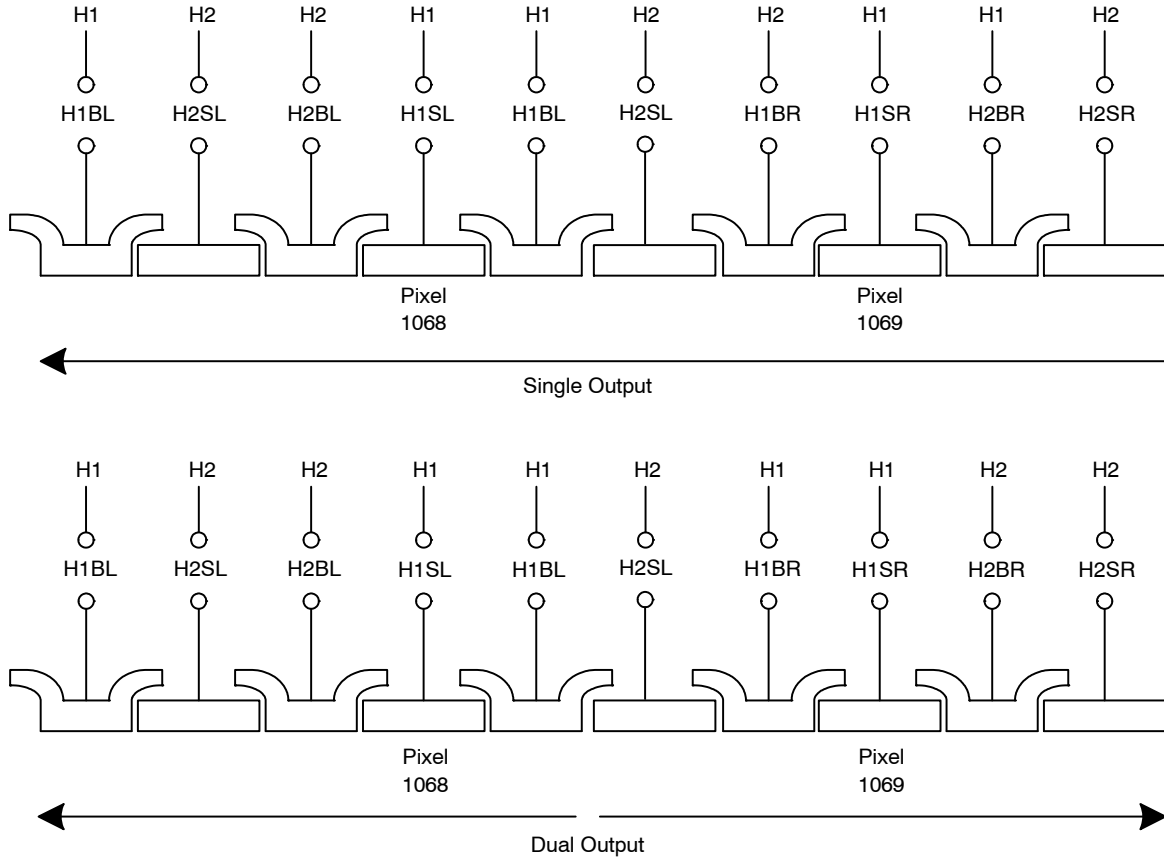

Figure 6. Horizontal Register

*Single Output Operation*

When operating the sensor in single output mode all pixels of the image sensor will be shifted out the Video L output (pin 12). To conserve power and lower heat generation the output amplifier for Video R may be turned off by connecting VDDR (pin 24) and VOUTR (pin 23) to GND (zero volts).

The H1 timing from the timing diagrams should be applied to H1SL, H1BL, H1SR, H2BR, and the H2 timing should be applied to H2SL, H2BL, H2SR, and H1BR. In other words, the clock driver generating the H1 timing should be connected to pins 16, 15, 19, and 21. The clock driver generating the H2 timing should be connected to pins 17, 14, 18, and 20. The horizontal CCD should be clocked for 12 empty pixels plus 28 light shielded pixels plus 2056 photoactive pixels plus 28 light shielded pixels for a total of 2124 pixels.

*Dual Output Operation*

In dual output mode the connections to the H1BR and H2BR pins are swapped from the single output mode to change the direction of charge transfer of the right side horizontal shift register. In dual output mode both VDDL and VDDR (pins 11, 24) should be connected to 15 V. The H1 timing from the timing diagrams should be applied to H1SL, H1BL, H1SR, H1BR, and the H2 timing should be applied to H2SL, H2BL, H2SR, and H2BR. The clock driver generating the H1 timing should be connected to pins 16, 15, 19, and 20. The clock driver generating the H2 timing should be connected to pins 17, 14, 18, and 21. The horizontal CCD should be clocked for 12 empty pixels plus 28 light shielded pixels plus 1028 photoactive pixels for a total of 1068 pixels. If the camera is to have the option of dual or single output mode, the clock driver signals sent to H1BR and H2BR may be swapped by using a relay. Another alternative is to have two extra clock drivers for H1BR and H2BR and invert the signals in the timing logic generator. If two extra clock drivers are used, care must be taken to ensure the rising and falling edges of the H1BR and H2BR clocks occur at the same time (within 3 ns) as the other HCCD clocks.



## Output

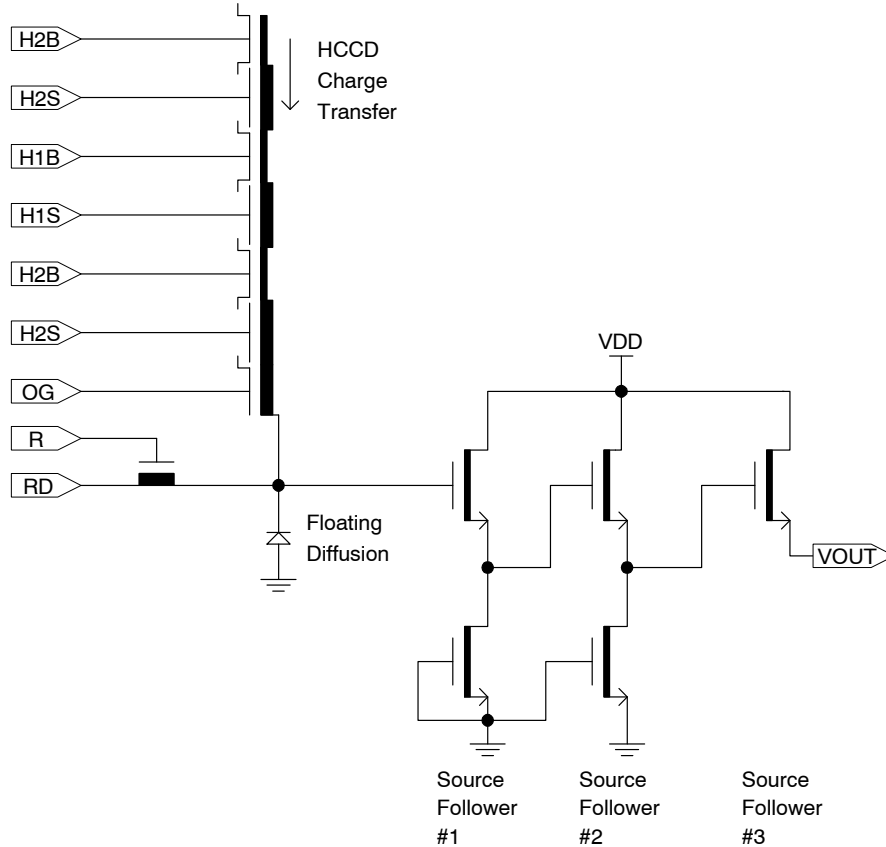

Figure 7. Output Architecture

Charge packets contained in the horizontal register are dumped pixel by pixel onto the floating diffusion (FD) output node whose potential varies linearly with the quantity of charge in each packet. The amount of potential change is determined by the expression  $\Delta V_{FD} = \Delta Q / C_{FD}$ . A three-stage source-follower amplifier is used to buffer this signal voltage off chip with slightly less than unity gain. The translation from the charge domain to the voltage domain is quantified by the output sensitivity or charge to voltage conversion in terms of microvolts per electron ( $\mu V/e^-$ ). After the signal has been sampled off chip, the reset clock (R) removes the charge from the floating diffusion and resets its potential to the reset drain voltage (RD).

When the image sensor is operated in the binned or summed interlaced modes there will be more than 40,000  $e^-$  in the output signal. The image sensor is designed with a  $16 \mu V/e^-$  charge to voltage conversion on the output. This means a full signal of 40,000 electrons will produce a 640 mV change on the output amplifier. The output amplifier was designed to handle an output swing of 640 mV at a pixel rate of 40 MHz. If 80,000 electron charge packets

are generated in the binned or summed interlaced modes then the output amplifier output will have to swing 1,280 mV. The output amplifier does not have enough bandwidth (slew rate) to handle 1,280 mV at 40 MHz. Hence, the pixel rate will have to be reduced to 20 MHz if the full dynamic range of 80,000 electrons is desired.

The charge handling capacity of the output amplifier is also set by the reset clock voltage levels. The reset clock driver circuit is very simple, if an amplitude of 5 V is used. But the 5 V amplitude restricts the output amplifier charge capacity to 40,000 electrons. If the full dynamic range of 80,000 electrons is desired then the reset clock amplitude will have to be increased to 7 V.

If you only want a maximum signal of 40,000 electrons in binned or summed interlaced modes, then a 40 MHz pixel rate with a 5 V reset clock may be used. The output of the amplifier will be unpredictable above 40,000 electrons so be sure to set the maximum input signal level of your analog to digital converter to the equivalent of 40,000 electrons (640 mV).

ESD Protection

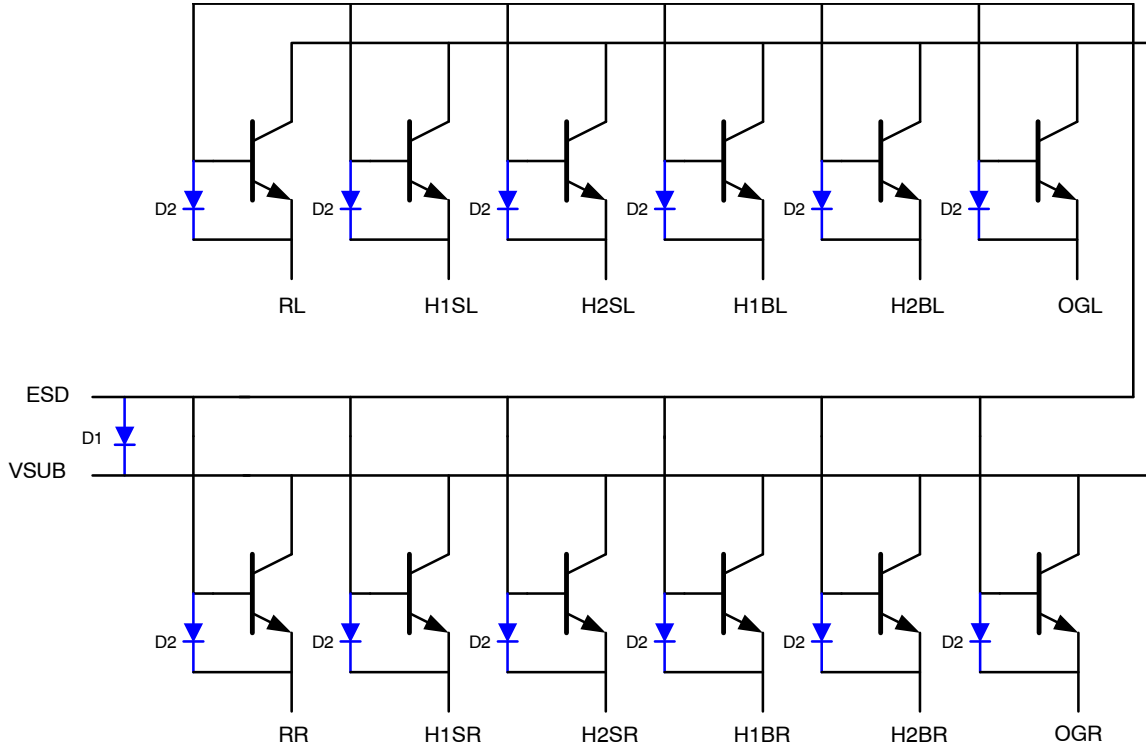

Figure 8. ESD Protection

The ESD protection on the KAI-4011 is implemented using bipolar transistors. The substrate (VSUB) forms the common collector of all the ESD protection transistors. The ESD pin is the common base of all the ESD protection transistors. Each protected pin is connected to a separate emitter as shown in Figure 8.

The ESD circuit turns on if the base-emitter junction voltage exceeds 17 V. Care must be taken while operating the image sensor, especially during the power on sequence, to not forward bias the base-emitter or base-collector junctions. If it is possible for the camera power up sequence

to forward bias these junctions then diodes D1 and D2 should be added to protect the image sensor. Put one diode D1 between the ESD and VSUB pins. Put one diode D2 on each pin that may forward bias the base-emitter junction. The diodes will prevent large currents from flowing through the image sensor. Note that external diodes D1 and D2 are optional and are only needed if it is possible to forward bias any of the junctions.

Note that diodes D1 and D2 are added external to the KAI-4011.

# KAI-4011

## Pin Description and Physical Orientation

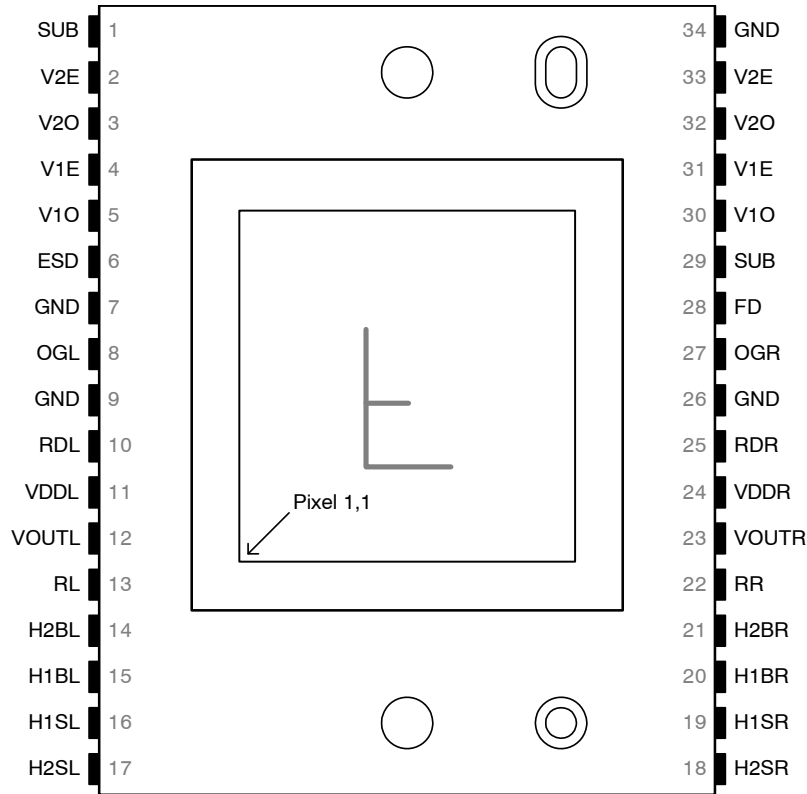

Figure 9. Package Pin Designations – Top View

Table 4. PIN DESCRIPTION

Pin	Name	Description
1	SUB	Substrate
2	V2E	Vertical Clock, Phase 2, Even
3	V2O	Vertical Clock, Phase 2, Odd
4	V1E	Vertical Clock, Phase 1, Even
5	V1O	Vertical Clock, Phase 1, Odd
6	ESD	ESD
7	GND	Ground
8	OGL	Output Gate, Left
9	GND	Ground
10	RDL	Reset Drain, Left
11	VDDL	V <sub>DD</sub> , Left
12	VOUTL	Video Output, Left
13	RL	Reset Gate, Left
14	H2BL	H2 Barrier, Left
15	H1BL	H1 Barrier, Left
16	H1SL	H1 Storage, Left
17	H2SL	H2 Storage, Left

Pin	Name	Description
18	H2SR	H2 Storage, Right
19	H1SR	H1 Storage, Right
20	H1BR	H1 Barrier, Right
21	H2BR	H2 Barrier, Right
22	RR	Reset Gate, Right
23	VOUTR	Video Output, Right
24	VDDR	V <sub>DD</sub> , Right
25	RDR	Reset Drain, Right
26	GND	Ground
27	OGR	Output Gate, Right
28	FD	Fast Line Dump Gate
29	SUB	Substrate
30	V1O	Vertical Clock, Phase 1, Odd
31	V1E	Vertical Clock, Phase 1, Even
32	V2O	Vertical Clock, Phase 2, Odd
33	V2E	Vertical Clock, Phase 2, Even
34	GND	Ground

NOTE: The pins are on a 0.070" spacing.

## IMAGING PERFORMANCE

**Table 5. TYPICAL OPERATIONAL CONDITIONS**

(Unless otherwise noted, the Imaging Performance Specifications are measured using the following conditions.)

Description	Condition	Notes
Frame Time	538 ms	1
Horizontal Clock Frequency	10 MHz	
Light Source	Continuous Red, Green and Blue LED Illumination Centered at 450, 530 and 650 nm	2, 3
Operation	Nominal Operating Voltages and Timing	

1. Electronic shutter is not used. Integration time equals frame time.
2. LEDs used: Blue: Nichia NLPB500, Green: Nichia NSPG500S and Red: HP HLMP-8115.
3. For monochrome sensor, only green LED used.

## Specifications

**Table 6. PERFORMANCE SPECIFICATIONS**

Description	Symbol	Min.	Nom.	Max.	Units	Sampling Plan	Temperature Tested at (°C)
<b>ALL CONFIGURATIONS</b>							
Dark Center Non-Uniformity		N/A	N/A	1	mVrms	Die	27, 40
Dark Global Non-Uniformity		N/A	N/A	5.0	mVpp	Die	27, 40
Global Non-Uniformity (Note 1)		N/A	2.5	5.0	% rms	Die	27, 40
Global Peak to Peak Non-Uniformity (Note 1)	PRNU	N/A	10	20	% pp	Die	27, 40
Center Non-Uniformity (Note 1)		N/A	1.0	2.0	% rms	Die	27, 40
Maximum Photoresponse Non-Linearity (Notes 2, 3)	NL	N/A	2		%	Design	
Maximum Gain Difference between Outputs (Notes 2, 3)	$\Delta G$	N/A	10		%	Design	
Maximum Signal Error due to Non-Linearity Dif. (Notes 2, 3)	$\Delta NL$	N/A	1		%	Design	
Horizontal CCD Charge Capacity	$H_{Ne}$		100		$ke^-$	Design	
Vertical CCD Charge Capacity	$V_{Ne}$	50	60		$ke^-$	Die	
Photodiode Charge Capacity	$P_{Ne}$	38	40		$ke^-$	Die	
Horizontal CCD Charge Transfer Efficiency	HCTE	0.99999		N/A		Design	
Vertical CCD Charge Transfer Efficiency	VCTE	0.99999		N/A		Design	
Photodiode Dark Current	$I_{PD}$	N/A N/A	40 0.01	350 0.1	e/p/s nA/cm <sup>2</sup>	Die	
Vertical CCD Dark Current	$I_{VD}$	N/A N/A	400 0.12	1711 0.5	e/p/s nA/cm <sup>2</sup>	Die	
Image Lag	Lag	N/A	< 10	50	$e^-$	Design	
Anti-Blooming Factor	$X_{AB}$	100	300	N/A			
Vertical Smear	Smr	N/A	-80	-75	dB		
Total Noise (Note 4)	$n_{e-T}$		23		$e^-$ rms	Design	
Total Noise (Note 5)	$n_{e-T}$		40		$e^-$ rms	Design	
Dynamic Range (Notes 5, 6)	DR		60		dB	Design	
Output Amplifier DC Offset	$V_{ODC}$	4	8.5	14	V	Die	

# KAI-4011

**Table 6. PERFORMANCE SPECIFICATIONS** (continued)

Description	Symbol	Min.	Nom.	Max.	Units	Sampling Plan	Temperature Tested at (°C)
<b>ALL CONFIGURATIONS</b>							
Output Amplifier Bandwidth	$f_{-3DB}$		140		MHz	Design	
Output Amplifier Impedance	$R_{OUT}$	100	130	200	$\Omega$	Die	
Output Amplifier Sensitivity	$\Delta V/\Delta N$		16		$\mu V/e^-$	Design	
<b>KAI-4011-ABA CONFIGURATION</b>							
Peak Quantum Efficiency	$QE_{MAX}$	45	55	N/A	%	Design	
Peak Quantum Efficiency Wavelength	$\lambda_{QE}$	N/A	500	N/A	nm	Design	
<b>KAI-4011-CBA CONFIGURATION*</b>							
Peak Quantum Efficiency	$QE_{MAX}$				%	Design	
Red		–	35	N/A			
Green		–	42	N/A			
Blue		–	45	N/A			
Peak Quantum Efficiency Wavelength	$\lambda_{QE}$				nm	Design	
Red		–	620	N/A			
Green		–	540	N/A			
Blue		–	470	N/A			

NOTE: N/A = Not Applicable.

\*Not recommended for new designs.

1. Per color.
2. Value is over the range of 10% to 90% of photodiode saturation.
3. Value is for the sensor operated without binning.
4. Includes system electronics noise, dark pattern noise and dark current shot noise at 20 MHz.
5. Includes system electronics noise, dark pattern noise and dark current shot noise at 40 MHz.
6. Uses 20LOG ( $P_{Ne} / n_{e-T}$ ).



TYPICAL PERFORMANCE CURVES

Quantum Efficiency

*Monochrome with Microlens*

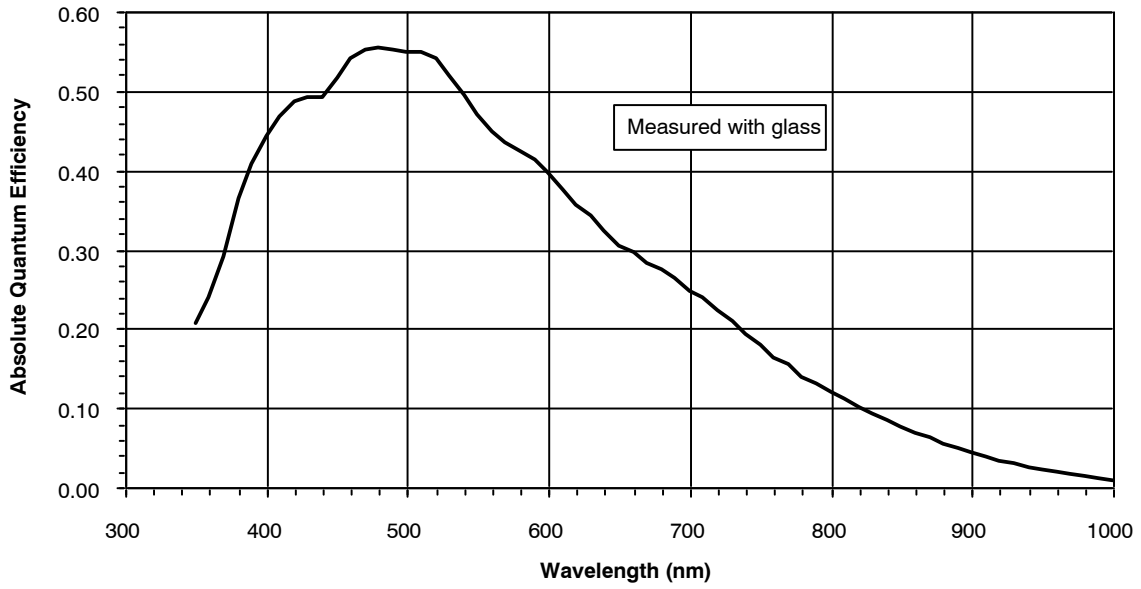

Figure 10. Monochrome with Microlens Quantum Efficiency

*Monochrome without Microlens*

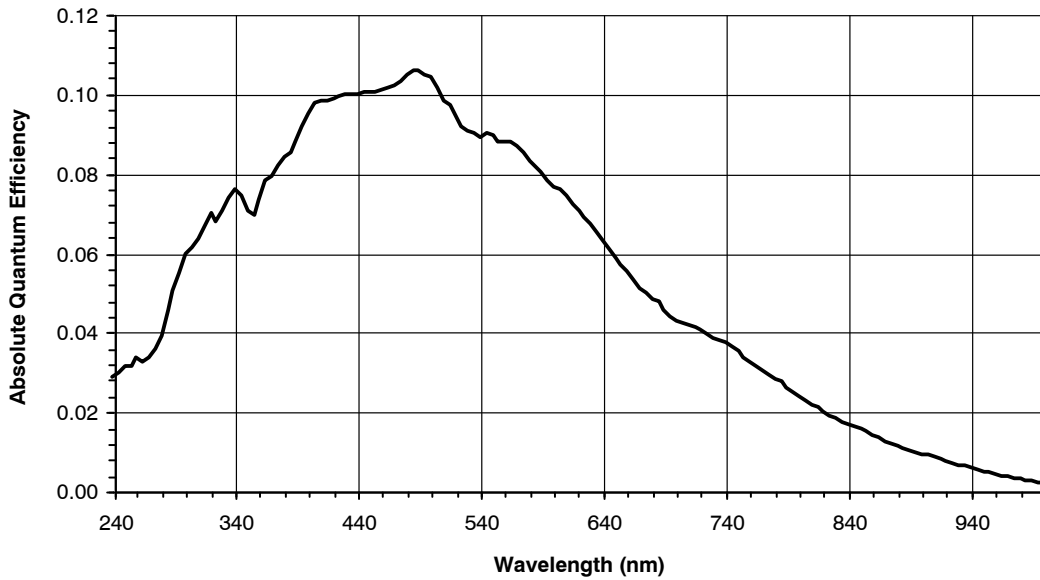

Figure 11. Monochrome without Microlens Quantum Efficiency

# KAI-4011

Color (Bayer RGB) with Microlens\*

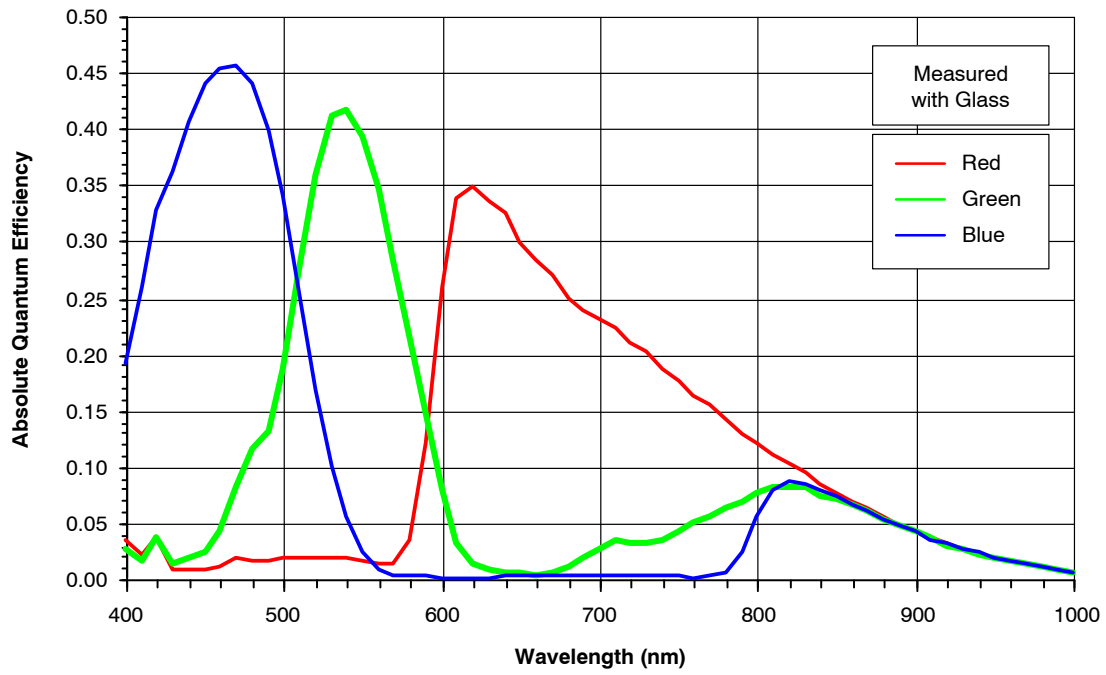

Figure 12. Color Quantum Efficiency

\*Not recommended for new designs.

**Angular Quantum Efficiency**

For the curves marked “Horizontal”, the incident light angle is varied in a plane parallel to the HCCD.  
 For the curves marked “Vertical”, the incident light angle is varied in a plane parallel to the VCCD.

*Monochrome with Microlens*

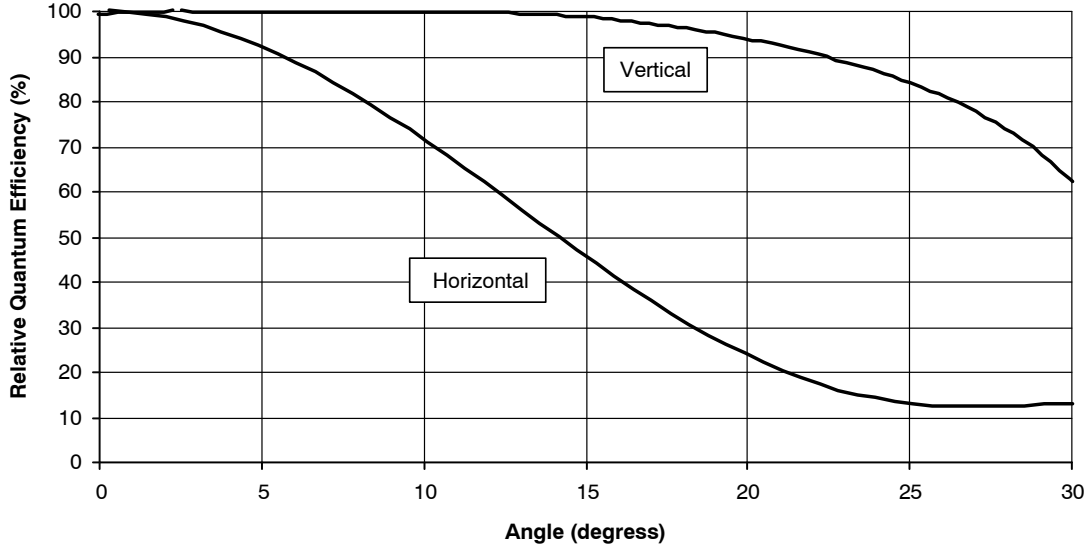

Figure 13. Angular Quantum Efficiency

**Dark Current vs. Temperature**

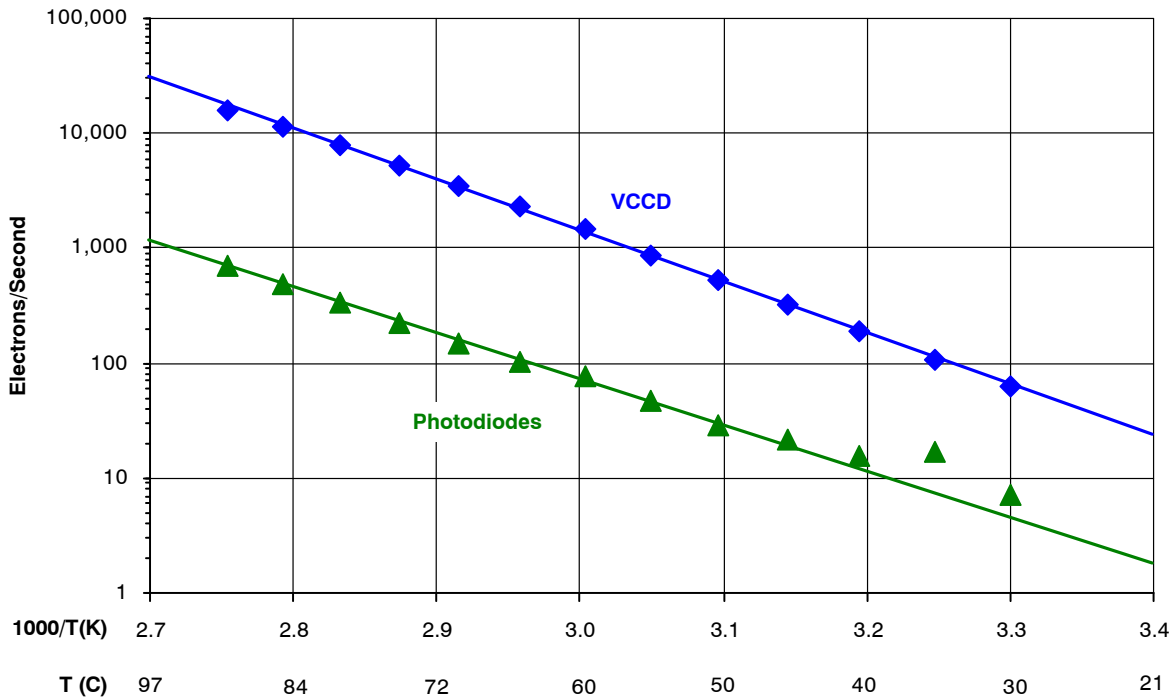

Figure 14. Dark Current vs. Temperature

Power-Estimated

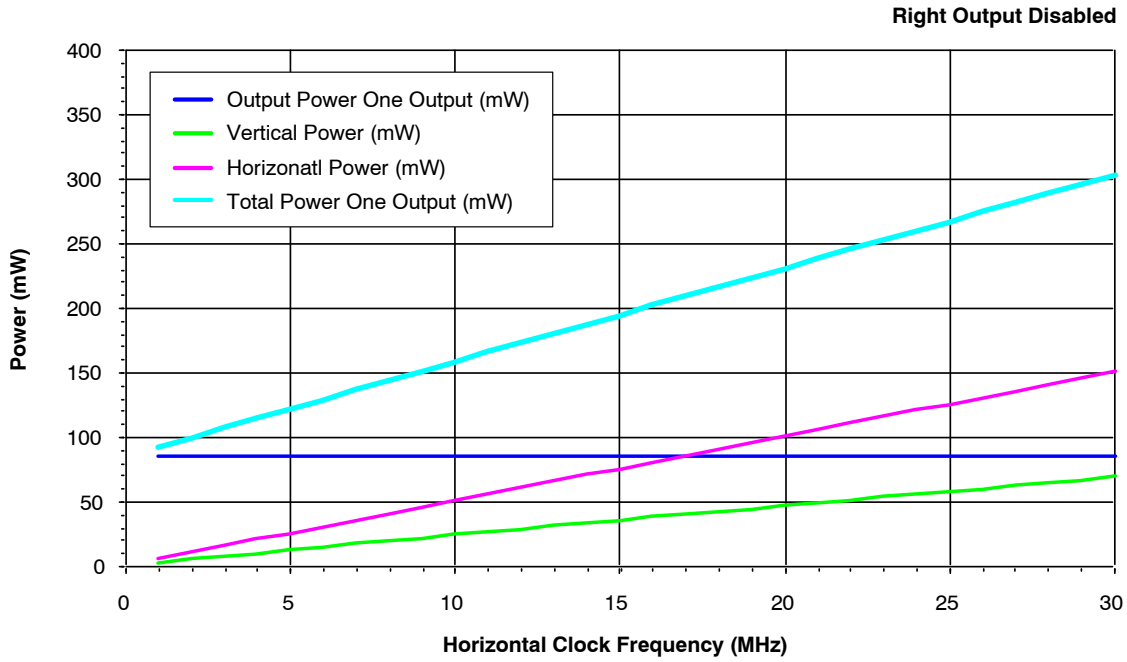

Figure 15. Power

Frame Rates

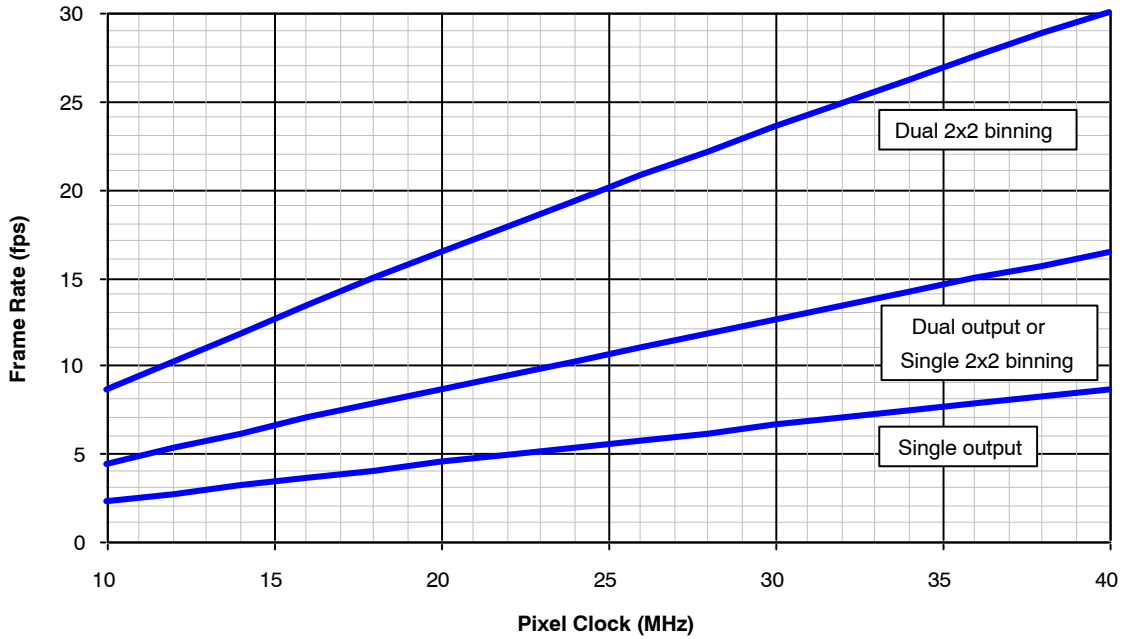

Figure 16. Frame Rates

**DEFECT DEFINITIONS**

**Table 7. DEFECT DEFINITIONS**

Description	Definition	Maximum	Temperature(s) Tested at (°C)	Notes
Major Dark Field Defective Pixel	Defect $\geq$ 74 mV	40	27, 40	1
Major Bright Field Defective Pixel	Defect $\geq$ 10%	40	27, 40	1
Minor Dark Field Defective Pixel	Defect $\geq$ 38 mV	400	27, 40	
Dead Pixel	Defect $\geq$ 80%	5	27, 40	1
Saturated Pixel	Defect $\geq$ 170 mV	10	27, 40	1
Cluster Defect	A group of 2 to 10 contiguous major defective pixels, but no more than 2 adjacent defects horizontally.	8	27, 40	1
Column Defect	A group of more than 10 contiguous major defective pixels along a single column.	0	27, 40	1

1. There will be at least two non-defective pixels separating any two major defective pixels or clusters.

**Defect Map**

The defect map supplied with each sensor is based upon testing at an ambient (27°C) temperature. Minor point

defects are not included in the defect map. All defective pixels are reference to pixel (1, 1) in the defect maps.



**TEST DEFINITIONS**

**Test Regions of Interest**

Active Area ROI: Pixel (1, 1) to Pixel (2048, 2048)  
 Center 100 by 100 ROI: Pixel (974, 974) to Pixel (1073, 1073)

Only the active pixels are used for performance and defect tests.

**Overclocking**

The test system timing is configured such that the sensor is overclocked in both the vertical and horizontal directions. See Figure 17 for a pictorial representation of the regions.

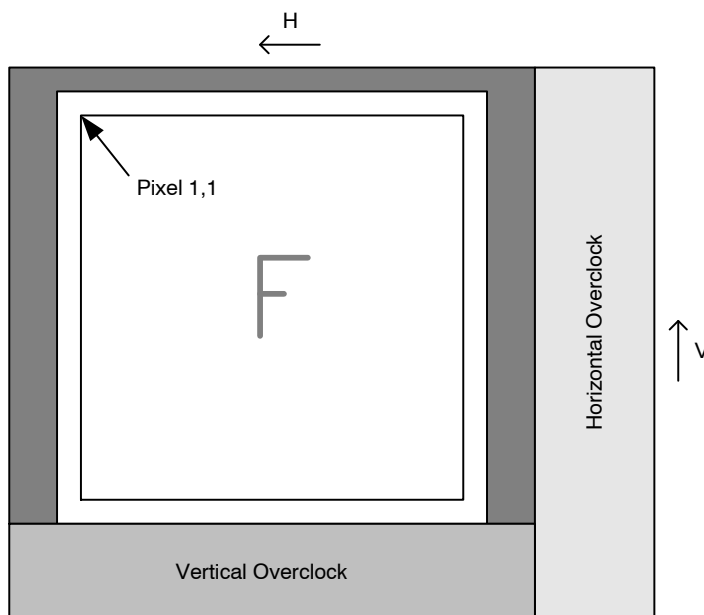

**Figure 17. Overclock Regions of Interest**

**Tests**

*Dark Field Center Non-Uniformity*

This test is performed under dark field conditions. Only the center 100 by 100 pixels of the sensor are used for this test – pixel (974, 974) to pixel (1073, 1073).

$$\text{Dark Field Center Uniformity} = \text{Standard Deviation of Center 100 by 100 Pixels in mV}$$

Units: mV rms

*Dark Field Global Non-Uniformity*

This test is performed under dark field conditions. The sensor is partitioned into 256 sub regions of interest, each of which is 128 by 128 pixels in size. The average signal level of each of the 256 sub regions of interest is calculated. The signal level of each of the sub regions of interest is calculated using the following formula:

$$\begin{aligned} \text{Signal of ROI}[i] = & (\text{ROI Average in ADU} - \\ & - \text{Horizontal Overclock Average in ADU}) \cdot \\ & \cdot \text{mV per Count} \end{aligned}$$

Units : mVpp (millivolts Peak to Peak)

Where i = 1 to 256. During this calculation on the 256 sub regions of interest, the maximum and minimum signal levels are found. The dark field global non-uniformity is then

calculated as the maximum signal found minus the minimum signal level found.

*Global Non-Uniformity*

This test is performed with the imager illuminated to a level such that the output is at 70% of saturation (approximately 448 mV). Prior to this test being performed the substrate voltage has been set such that the charge capacity of the sensor is 640 mV. Global non-uniformity is defined as:

$$\text{Global Non-Uniformity} = 100 \cdot \left( \frac{\text{Active Area Standard Deviation}}{\text{Active Area Signal}} \right)$$

Units : % rms

$$\begin{aligned} \text{Active Area Signal} = & \text{Active Area Average} - \\ & - \text{Horizontal Overclock Average} \end{aligned}$$

*Global Peak to Peak Non-Uniformity*

This test is performed with the imager illuminated to a level such that the output is at 70% of saturation (approximately 448 mV). Prior to this test being performed the substrate voltage has been set such that the charge capacity of the sensor is 640 mV. The sensor is partitioned into 256 sub regions of interest, each of which is 128 by 128 pixels in size. The average signal level of each of the 256 sub regions of interest (ROI) is calculated. The signal level of each of the sub regions of interest is calculated using the following formula:

$$A[i] = (\text{ROI Average} - \text{Horizontal Overclock Average})$$

Where  $i = 1$  to 256. During this calculation on the 256 sub regions of interest, the maximum and minimum average signal levels are found. The global peak to peak non-uniformity is then calculated as:

$$\text{Global NonUniformity} = 100 \cdot \frac{A[i] \text{ Max. Signal} - A[i] \text{ Min. Signal}}{\text{Active Area Signal}}$$

Units : % pp

$$\text{Active Area Signal} = \text{Active Area Average} - \text{Horizontal Overclock Average}$$

*Center Non-Uniformity*

This test is performed with the imager illuminated to a level such that the output is at 70% of saturation (approximately 448 mV). Prior to this test being performed the substrate voltage has been set such that the charge capacity of the sensor is 640 mV. Defects are excluded for the calculation of this test. This test is performed on the center 100 by 100 pixels (see Test Regions of Interest) of the sensor. Center non-uniformity is defined as:

$$\begin{aligned} \text{Center ROI Non-Uniformity} &= \\ &= 100 \cdot \left( \frac{\text{Center ROI Standard Deviation}}{\text{Center ROI Signal}} \right) \end{aligned}$$

Units : % rms

$$\text{Center ROI Signal} = \text{Center ROI Average} - \text{Horizontal Overclock Average}$$

*Dark Field Defect Test*

This test is performed under dark field conditions. The sensor is partitioned into 256 sub regions of interest, each of which is 128 by 128 pixels in size. In each region of interest, the median value of all pixels is found. For each region of interest, a pixel is marked defective if it is greater than or equal to the median value of that region of interest plus the defect threshold specified in “Defect Definitions” section.

*Bright Field Defect Test*

This test is performed with the imager illuminated to a level such that the output is at 70% of saturation (approximately 28,000 electrons). Prior to this test being performed the substrate voltage has been set such that the charge capacity of the sensor is 40,000 electrons. The average signal level of all active pixels is found. The bright and dark thresholds are set as:

$$\text{Dark Defect Threshold} = \text{Active Area Signal} \cdot \text{Threshold}$$

$$\text{Bright Defect Threshold} = \text{Active Area Signal} \cdot \text{Threshold}$$

The sensor is then partitioned into 256 sub regions of interest, each of which is 128 by 128 pixels in size. In each region of interest, the average value of all pixels is found. For each region of interest, a pixel is marked defective if it is greater than or equal to the median value of that region of interest plus the bright threshold specified or if it is less than or equal to the median value of that region of interest minus the dark threshold specified.

Example for major bright field defective pixels:

- Average value of all active pixels is found to be 448 mV (28,000 electrons).
- Dark defect threshold:  $448 \text{ mV} \cdot 15\% = 67.2 \text{ mV}$ .
- Bright defect threshold:  $448 \text{ mV} \cdot 15\% = 67.2 \text{ mV}$ .
- Region of interest #1 selected. This region of interest is pixels 1, 1 to pixels 128, 128.
  - ◆ Median of this region of interest is found to be 448 mV.
  - ◆ Any pixel in this region of interest that is  $\geq (448 + 67.2 \text{ mV}) 515.2 \text{ mV}$  in intensity will be marked defective.
  - ◆ Any pixel in this region of interest that is  $\leq (448 - 67.2 \text{ mV}) 380.8 \text{ mV}$  in intensity will be marked defective.
- All remaining 255 sub regions of interest are analyzed for defective pixels in the same manner.

## OPERATION

### Absolute Maximum Ratings

Absolute maximum rating is defined as a level or condition that should not be exceeded at any time per the

description. If the level or the condition is exceeded, the device will be degraded and may be damaged.

**Table 8. ABSOLUTE MAXIMUM RATINGS**

Description	Symbol	Minimum	Maximum	Units	Notes
Operating Temperature	T <sub>OP</sub>	-50	70	°C	1
Humidity	RH	5	90	%	2
Output Bias Current	I <sub>OUT</sub>	0.0	10	mA	3
Off-Chip Load	C <sub>L</sub>		10	pF	4

Stresses exceeding those listed in the Maximum Ratings table may damage the device. If any of these limits are exceeded, device functionality should not be assumed, damage may occur and reliability may be affected.

- Noise performance will degrade at higher temperatures.
- T = 25°C. Excessive humidity will degrade MTTF.
- Each output. See Figure 18: Output Amplifier. Note that the current bias affects the amplifier bandwidth.
- With total output load capacitance of C<sub>L</sub> = 10 pF between the outputs and AC ground.

**Table 9. MAXIMUM VOLTAGE RATINGS BETWEEN PINS**

Description	Minimum	Maximum	Units	Notes
RL, RR, H1S, H2S, H1BL, H2BL, H1BR, H2BR, OGR, OGL to ESD	0	17	V	
Pin to Pin with ESD Protection	-17	17	V	1
VDDL, VDDR to GND	0	25	V	

- Pins with ESD protection are: RL, RR, H1S, H2S, H1BL, H2BL, H1BR, H2BR, OGL, and OGR.

**Table 10. DC BIAS OPERATING CONDITIONS**

Description	Symbol	Min.	Nom.	Max.	Units	Maximum DC Current	Notes
Output Gate	OG	-4.0	-3.5	-3.0	V	1 μA	
Reset Drain	RD	11.5	12.0	12.5	V	1 μA	
Output Amplifier Supply	V <sub>DD</sub>	14.5	15.0	15.5	V	1 mA	3
Ground	GND	0.0	0.0	0.0	V		
Substrate	SUB	8.0	V <sub>AB</sub>	17.0	V		1, 5
ESD Protection	ESD	-9.5	-9.0	-8.0	V		2
Output Bias Current	I <sub>OUT</sub>	0.0	5.0	10.0	mA		4

- The operating value of the substrate voltage, V<sub>AB</sub>, will be marked on the shipping container for each device. The value V<sub>AB</sub> is set such that the photodiode charge capacity is 40,000 electrons.
- V<sub>ESD</sub> must be equal to FDL and more negative than H1L, H2L and RL during sensors operation AND during camera power turn on.
- One output, unloaded. The maximum DC current is for one output unloaded and is shown as I<sub>SS</sub> in Figure 18. This is the maximum current that the first two stages of one output amplifier will draw. This value is with V<sub>out</sub> disconnected.
- One output.
- Refer to Application Note *Using Interline CCD Image Sensors in High Intensity Visible Lighting Conditions*.

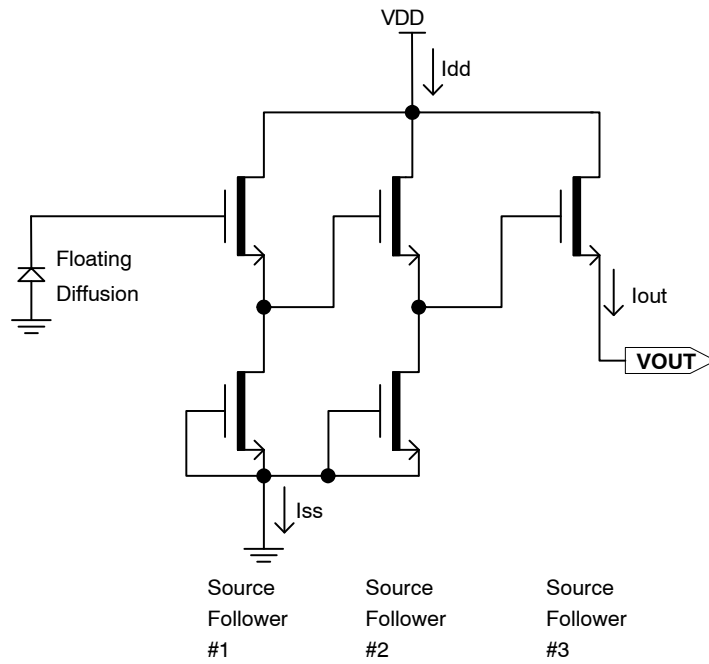

Figure 18. Output Amplifier

AC Operating Conditions

Table 11. CLOCK LEVELS

Description	Symbol	Min.	Nom.	Max.	Unit	Notes
Vertical CCD Clock High	V2H	8.5	9.0	9.5	V	
Vertical CCD Clocks Midlevel	V1M, V2M	-0.2	0.0	0.2	V	
Vertical CCD Clocks Low	V1L, V2L	-9.5	-9.0	-8.5	V	
Horizontal CCD Clocks High	H1H, H2H	0.0	0.5	1.0	V	
Horizontal CCD Clocks Low	H1L, H2L	-5.0	-4.5	-4.0	V	
Reset Clock Amplitude	RH		5.0		V	1
Reset Clock Low	RL	-3.5	-3.0	-2.5	V	2
Electronic Shutter Voltage	V <sub>SHUTTER</sub>	44	48	52	V	3
Fast Dump High	FDH	4	5	5	V	
Fast Dump Low	FDL	-9.5	-9	-8	V	

1. Reset amplitude must be set to 7.0 V for 80,000 electrons output in summed interlaced or binning modes.
2. Reset low level must be set to -5.0 V for 80,000 electrons output in summed interlaced or binning modes.
3. Refer to Application Note *Using Interline CCD Image Sensors in High Intensity Visible Lighting Conditions*.

Clock Line Capacitances

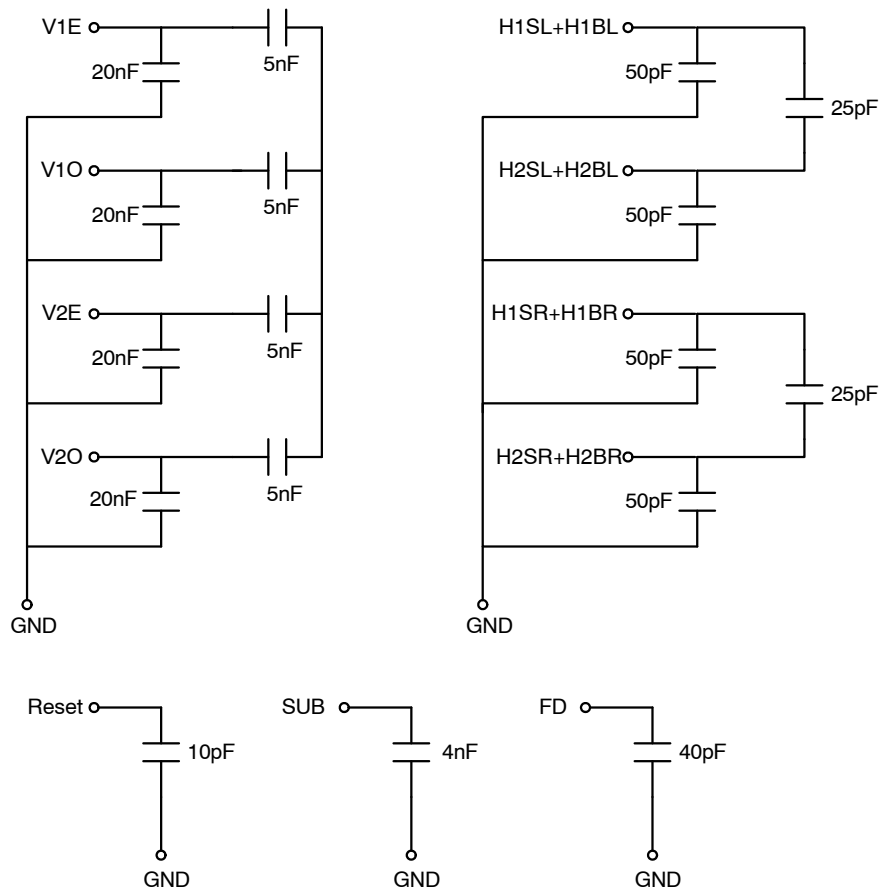

Figure 19. Clock Line Capacitances



**TIMING**

**Table 12. TIMING REQUIREMENTS**

Description	Symbol	Min.	Nom.	Max.	Units
HCCD Delay	$t_{HD}$	1.3	1.5	10.0	$\mu s$
VCCD Transfer Time	$t_{VCCD}$	1.3	1.5	20.0	$\mu s$
Photodiode Transfer Time	$t_{V3rd}$	3.0	5.0	15.0	$\mu s$
VCCD Pedestal Time	$t_{3P}$	50.0	60.0	80.0	$\mu s$
VCCD Delay	$t_{3D}$	10.0	20.0	80.0	$\mu s$
Reset Pulse Time	$t_R$	2.5	5.0		ns
Shutter Pulse Time	$t_S$	3.0	4.0	10.0	$\mu s$
Shutter Pulse Delay	$t_{SD}$	1.0	1.5	10.0	$\mu s$
HCCD Clock Period	$t_H$	25.0	50.0	200.0	ns
VCCD Rise/Fall Time	$t_{VR}$	0.0	0.1	1.0	$\mu s$
Fast Dump Gate Delay	$t_{FD}$	0.5			$\mu s$
Vertical Clock Edge Alignment	$t_{VE}$	0.0		100.0	ns

**Timing Modes**

*Progressive Scan*

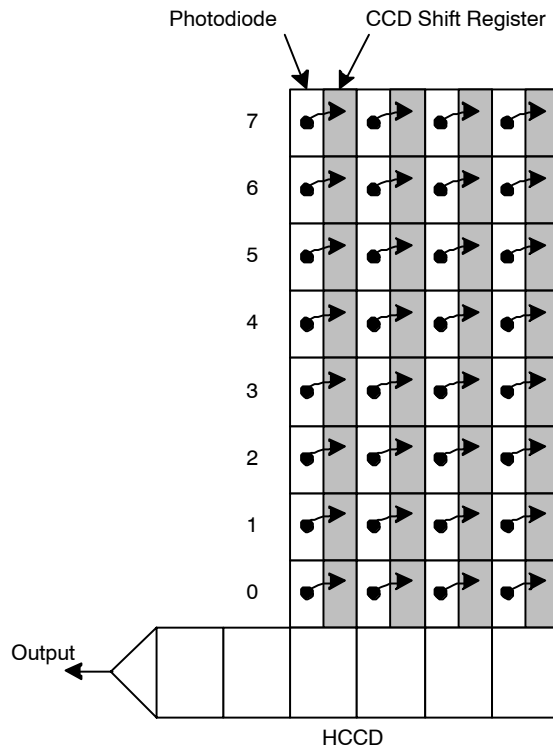

**Figure 20. Progressive Scan Operation**

In progressive scan read out every pixel in the image sensor is read out simultaneously. Each charge packet is transferred from the photodiode to the neighboring vertical

CCD shift register simultaneously. The maximum useful signal output is limited by the photodiode charge capacity to 40,000 electrons.

# KAI-4011

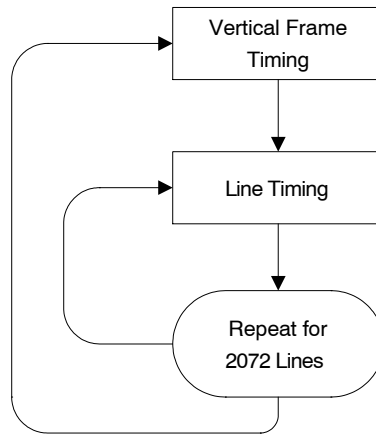

Figure 21. Progressive Scan Flow Chart

## Summed Interlaced Scan

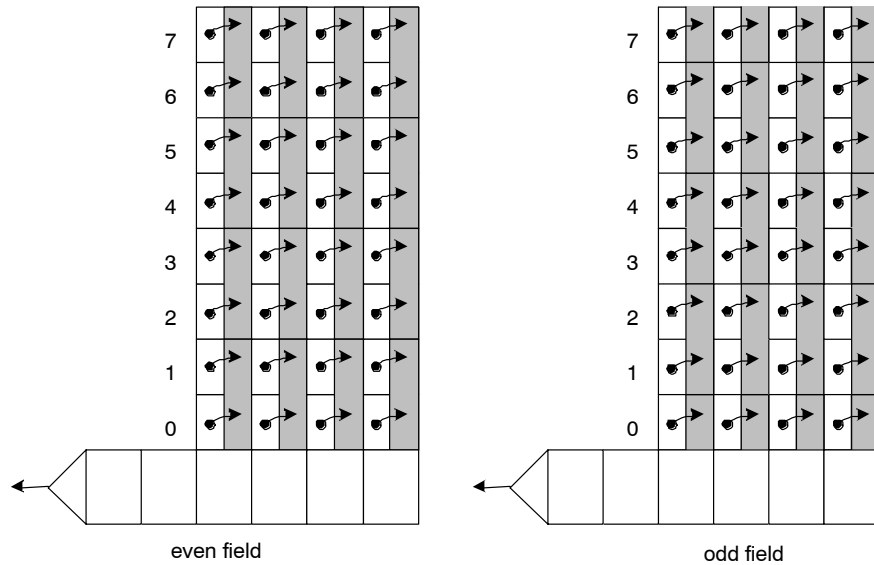

Figure 22. Summed Interlaced Scan Operation

In the summed interlaced scan read out mode, charge from two photodiodes is summed together inside the vertical CCD. The clocking of the VCCD is such that one pixel occupies the space equivalent to two pixels in the progressive scan mode. This allows the VCCD to hold twice as many electrons as in progressive scan mode. Now the maximum useful signal is limited by the charge capacity of two photodiodes at 80,000 electrons. If only one field is read out of the image sensor the apparent vertical resolution will be 1024 rows instead of the 2048 rows in progressive scan

(equivalent to binning). To recover the full resolution of the image sensor two fields, even and odd, are read out. In the even field rows 0+1, 2+3, 4+5, ... are summed together. In the odd field rows 1+2, 3+4, 5+6, ... are summed together.

The modulation transfer function (MTF) of the summed interlaced scan mode is less in the vertical direction than the progressive scan. But the dynamic range is twice that of progressive scan. The vertical MTF is better than a simple binning operation. In this mode the VCCD needs to be clocked for only 1037 rows to read out each field.

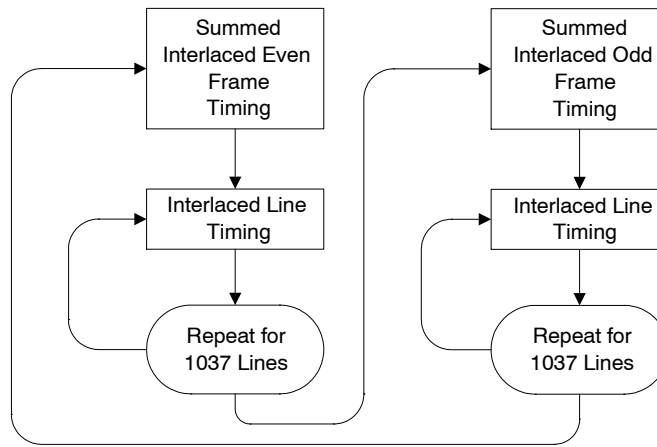

Figure 23. Summed Interlaced Scan Flow Chart

*Non-Summed Interlaced Scan*

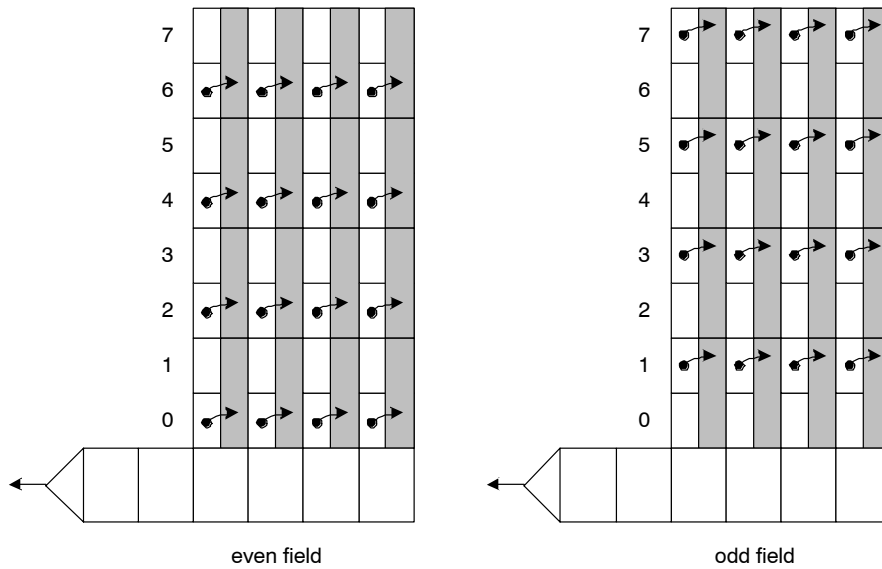

Figure 24. Non-Summed Interlaced Scan Operation

In the non-summed interlaced scan mode only half the photodiode are read out in each field. In the even field rows 0, 2, 4, ... are transferred to the VCCD. In the odd field rows 1, 3, 5, ... are transferred to the VCCD. When the charge packet is transferred from a photodiode it occupies the equivalent of two rows in progressive scan mode. This allows the VCCD to hold twice as much charge a progressive scan mode. However, since only one photodiode for each row is transferred to the VCCD the

maximum usable signal is still only 40,000 electrons. The large extra capacity of the VCCD causes the anti-blooming protection to be increased dramatically compared to the progressive scan. The vertical MTF is the same between the non-summed interlaced scan and progressive scan. There will be motion related artifacts in the images read out in the interlaced modes because the two fields are acquired at different times.