



Chipsmall Limited consists of a professional team with an average of over 10 year of expertise in the distribution of electronic components. Based in Hongkong, we have already established firm and mutual-benefit business relationships with customers from,Europe,America and south Asia,supplying obsolete and hard-to-find components to meet their specific needs.

With the principle of “Quality Parts,Customers Priority,Honest Operation,and Considerate Service”,our business mainly focus on the distribution of electronic components. Line cards we deal with include Microchip,ALPS,ROHM,Xilinx,Pulse,ON,Everlight and Freescale. Main products comprise IC,Modules,Potentiometer,IC Socket,Relay,Connector.Our parts cover such applications as commercial,industrial, and automotives areas.

We are looking forward to setting up business relationship with you and hope to provide you with the best service and solution. Let us make a better world for our industry!



Contact us

Tel: +86-755-8981 8866 Fax: +86-755-8427 6832

Email & Skype: info@chipsmall.com Web: www.chipsmall.com

Address: A1208, Overseas Decoration Building, #122 Zhenhua RD., Futian, Shenzhen, China



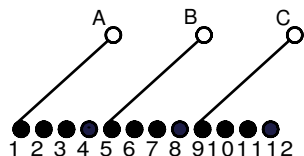

CONTACT CONFIGURATION
TIMING (BBM) NON-SHORTING

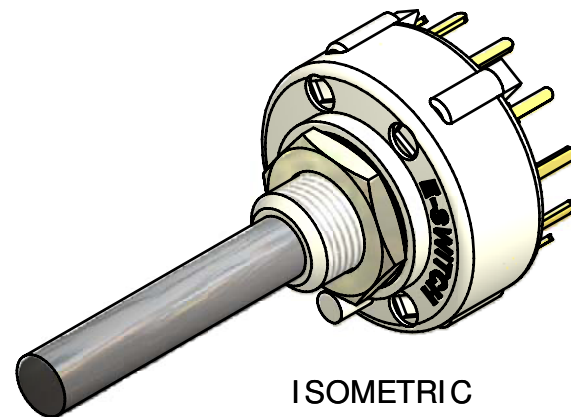
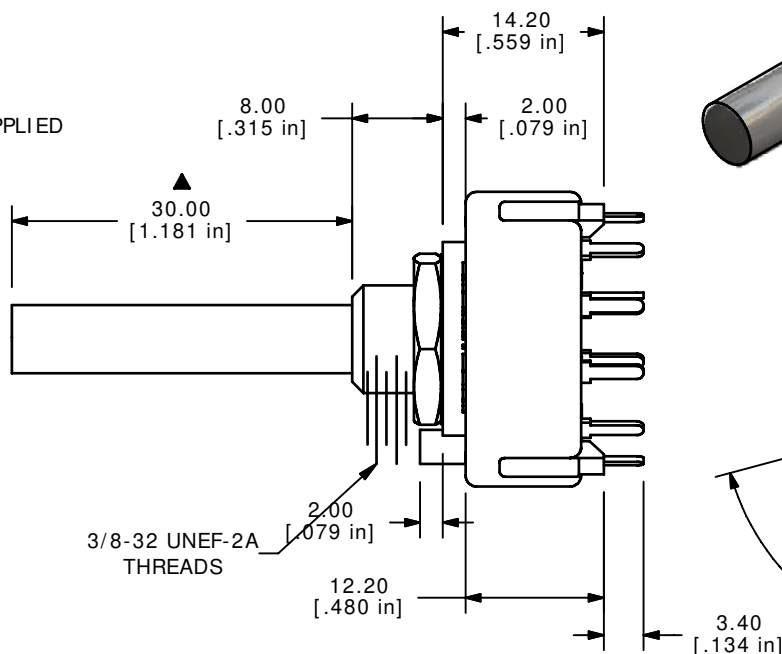
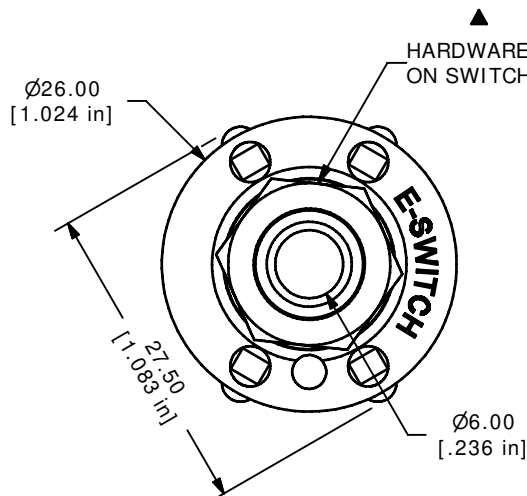

ISOMETRIC

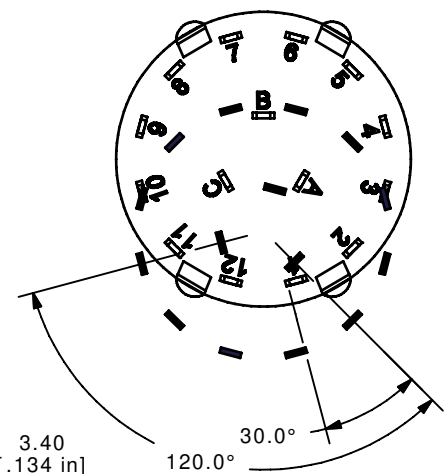

- NOTE:
1. ALL DIMENSIONS IN MM[INCH].
 2. GENERAL TOLERANCE: X.X=±0.4
X.XX=±0.25
 3. TERM. NOS. FOR REFERENCE ONLY.
 - ▲ 4. CONTACT MATERIAL: GOLD
 5. CONTACT RATING: 150MILLIAMP, 250VAC/DC
350MILLIAMP, 110VAC/DC
 6. CONTACT RATING (NON-SWITCHING) 5A
 7. OPERATING FORCE 425±100CM/STANDARD
 8. OPERATING TEMP: -30°C TO 85°C
 - ▲ 9. CIRCUIT 3P: 4 POSITION 30° INDEX.
 10. DIELECTRIC STRENGTH: 1000V RMS MIN.@ SEA LEVEL.
 - ▲ 11. HARDWARE SUPPLIED ON SWITCH:
LOCKWASHER, HEXNUT, & STOPRING.
 12. ▲ DENOTES CRITICAL PARAMETER.
 13. 2002/95/EC (ROHS) COMPLIANT
 - ▲ 14. PACKAGE: TRAY/462 PIECES PER



B	17928	add stopring to note 11	1/17/08	TN
A	16993	RELEASED FOR PRODUCTION	2/14/07	TN
REV	PCR NO	DESCRIPTION	DATE	BY

TITLE KC34B30.001NPF				
SCALE	DATE	DR	DWG	REV
1.5:1	2/14/2007	TN	G510359	B

THE INFORMATION CONTAINED IN THIS DOCUMENT IS PROPRIETARY TO E-SWITCH AND IS NOT TO BE COPIED OR TRANSFERRED