



Chipsmall Limited consists of a professional team with an average of over 10 year of expertise in the distribution of electronic components. Based in Hongkong, we have already established firm and mutual-benefit business relationships with customers from,Europe,America and south Asia,supplying obsolete and hard-to-find components to meet their specific needs.

With the principle of “Quality Parts,Customers Priority,Honest Operation,and Considerate Service”,our business mainly focus on the distribution of electronic components. Line cards we deal with include Microchip,ALPS,ROHM,Xilinx,Pulse,ON,Everlight and Freescale. Main products comprise IC,Modules,Potentiometer,IC Socket,Relay,Connector.Our parts cover such applications as commercial,industrial, and automotives areas.

We are looking forward to setting up business relationship with you and hope to provide you with the best service and solution. Let us make a better world for our industry!



Contact us

Tel: +86-755-8981 8866 Fax: +86-755-8427 6832

Email & Skype: info@chipsmall.com Web: www.chipsmall.com

Address: A1208, Overseas Decoration Building, #122 Zhenhua RD., Futian, Shenzhen, China



Very low drop voltage regulators with inhibit

Datasheet - production data

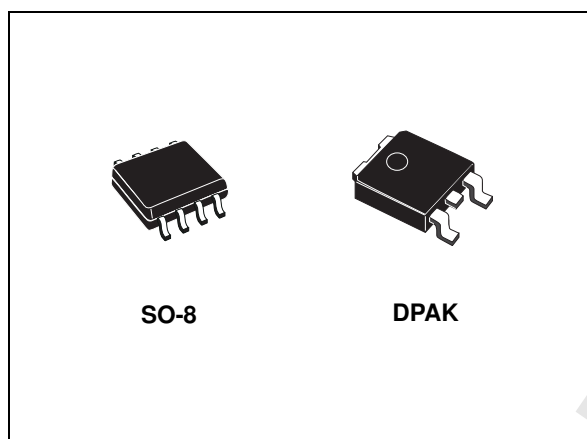

Description

The KF series are very low drop regulators available in SO-8 and DPAK packages and in a wide range of output voltages.

The very low dropout voltage (0.4 V) and the very low quiescent current make them particularly suitable for low noise, low power applications and especially in battery powered systems.

A shutdown logic control function is available (pin 5, TTL compatible). This means that when the device is used as a local regulator, it is possible to put a part of the board in standby, decreasing the total power consumption. It requires only a 2.2 μF capacitor for stability allowing space and cost saving.

Features

- Very low dropout voltage (0.4 V)
- Very low quiescent current (typ. 50 μA in OFF mode, 500 μA in ON mode)
- Output current up to 500 mA
- Logic-controlled electronic shutdown
- Output voltages of 2.5; 3.3; 5; 8 V
- Internal current and thermal limit
- Only 2.2 μF for stability
- Available in $\pm 2\%$ accuracy at 25 $^{\circ}\text{C}$
- Supply voltage rejection: 70 db (typ.)
- Temperature range: - 40 to 125 $^{\circ}\text{C}$

Table 1. Device summary

Order codes		Output voltages
SO-8 (tape and reel)	DPAK (tape and reel)	
KF25BD-TR	KF25BDT-TR	2.5 V
KF33BD-TR	KF33BDT-TR	3.3 V
KF50BD-TR	KF50BDT-TR	5 V
	KF80BDT-TR	8 V

Contents

1	Diagram	3
2	Pin configuration	4
3	Maximum ratings	5
4	Electrical characteristics	6
5	Typical performance characteristics	10
6	Package mechanical data	11
7	Packaging mechanical data	17
8	Revision history	20

DRAFT

2 Pin configuration

Figure 2. Pin connections (top view)

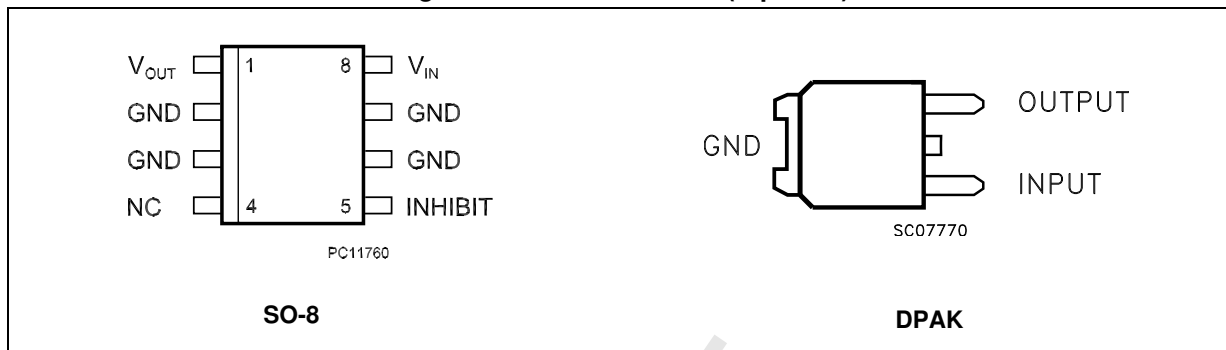

DRAFT

3 Maximum ratings

Table 2. Absolute maximum ratings

Symbol	Parameter	Value	Unit
V_I	DC input voltage	- 0.5 to 20	V
I_O	Output current	Internally Limited	
P_{TOT}	Power dissipation	Internally Limited	
T_{STG}	Storage temperature range	- 40 to 150	°C
T_{OP}	Operating junction temperature range	- 40 to 125	°C

Note: Absolute maximum ratings are those values beyond which damage to the device may occur. Functional operation under these condition is not implied.

Table 3. Thermal data

Symbol	Parameter	DPAK	SO-8	Unit
R_{thJC}	Thermal resistance junction-case	8	20	°C/W
R_{thJA}	Thermal resistance junction-ambient	100	55	°C/W

Figure 3. Test circuit

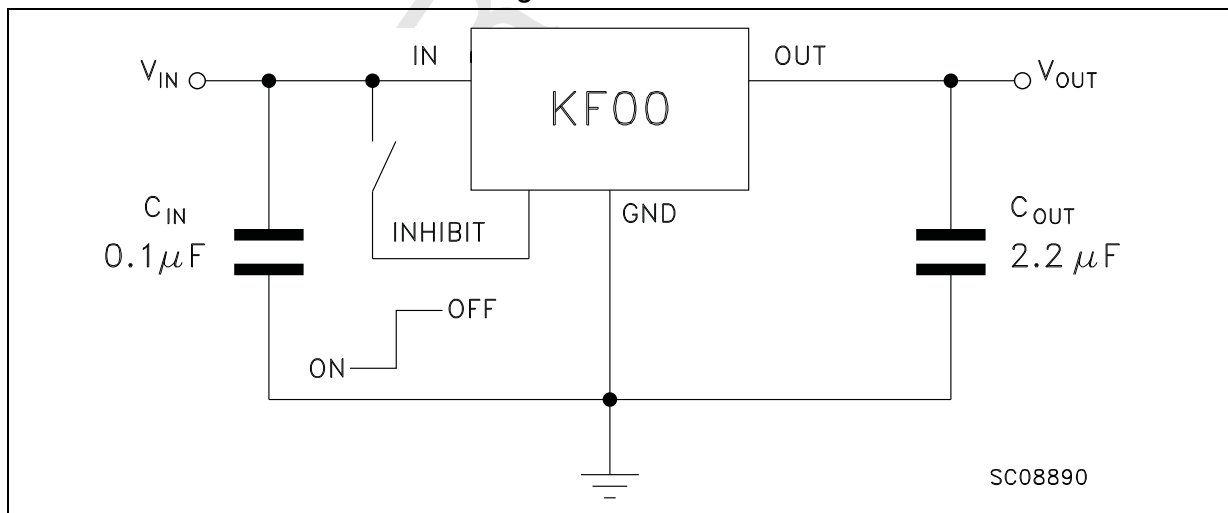

4 Electrical characteristics

Refer to the test circuits, $T_J = 25\text{ °C}$, $C_I = 0.1\text{ }\mu\text{F}$, $C_O = 2.2\text{ }\mu\text{F}$ unless otherwise specified.

Table 4. Electrical characteristics ($V_O = 2.5\text{ V}$)

Symbol	Parameter	Test conditions	Min.	Typ.	Max.	Unit
V_O	Output voltage	$I_O = 50\text{ mA}$, $V_I = 4.5\text{ V}$	2.45	2.5	2.55	V
		$I_O = 50\text{ mA}$, $V_I = 4.5\text{ V}$, $T_a = -25\text{ to }85\text{ °C}$	2.4		2.6	
V_I	Operating input voltage	$I_O = 500\text{ mA}$			20	V
I_O	Output current limit			1		A
ΔV_O	Line regulation	$V_I = 3.5\text{ to }20\text{ V}$, $I_O = 5\text{ mA}$		2	12	mV
ΔV_O	Load regulation	$V_I = 3.8\text{ V}$, $I_O = 5\text{ to }500\text{ mA}$		2	50	mV
I_d	Quiescent current	$V_I = 3.5\text{ to }20\text{ V}$, $I_O = 0\text{ mA}$	ON MODE	0.5	1	mA
		$V_I = 3.8\text{ to }20\text{ V}$, $I_O = 500\text{ mA}$			12	
		$V_I = 6\text{ V}$	OFF MODE		50	100
SVR	Supply voltage rejection	$I_O = 5\text{ mA}$, $V_I = 4.5 \pm 1\text{ V}$	$f = 120\text{ Hz}$	82		dB
			$f = 1\text{ kHz}$	77		
			$f = 10\text{ kHz}$	60		
eN	Output noise voltage	$B = 10\text{ Hz to }100\text{ KHz}$		50		μV
V_d	Dropout voltage	$I_O = 200\text{ mA}$		0.2	0.35	V
		$I_O = 500\text{ mA}$		0.4	0.7	
V_{IL}	Control input logic low	$T_a = -40\text{ to }125\text{ °C}$			0.8	V
V_{IH}	Control input logic high	$T_a = -40\text{ to }125\text{ °C}$	2			V
I_I	Control input current	$V_I = 6\text{ V}$, $V_C = 6\text{ V}$		10		μA
C_O	Output bypass capacitance	$\text{ESR} = 0.1\text{ to }10\text{ }\Omega$, $I_O = 0\text{ to }500\text{ mA}$	2	10		μF

Refer to the test circuits, $T_J = 25\text{ }^\circ\text{C}$, $C_I = 0.1\text{ }\mu\text{F}$, $C_O = 2.2\text{ }\mu\text{F}$ unless otherwise specified.

Table 5. Electrical characteristics ($V_O = 3.3\text{ V}$)

Symbol	Parameter	Test conditions	Min.	Typ.	Max.	Unit	
V_O	Output voltage	$I_O = 50\text{ mA}$, $V_I = 5.3\text{ V}$	3.234	3.3	3.366	V	
		$I_O = 50\text{ mA}$, $V_I = 5.3\text{ V}$, $T_a = -25\text{ to }85\text{ }^\circ\text{C}$	3.168		3.432		
V_I	Operating input voltage	$I_O = 500\text{ mA}$			20	V	
I_O	Output current limit			1		A	
ΔV_O	Line regulation	$V_I = 4.3\text{ to }20\text{ V}$, $I_O = 5\text{ mA}$		2	12	mV	
ΔV_O	Load regulation	$V_I = 4.6\text{ V}$, $I_O = 5\text{ to }500\text{ mA}$		2	50	mV	
I_d	Quiescent current	$V_I = 4.3\text{ to }20\text{ V}$, $I_O = 0\text{ mA}$	ON MODE		0.5	1	mA
		$V_I = 4.6\text{ to }20\text{ V}$, $I_O = 500\text{ mA}$				12	
		$V_I = 6\text{ V}$	OFF MODE		50	100	μA
SVR	Supply voltage rejection	$I_O = 5\text{ mA}$, $V_I = 5.3 \pm 1\text{ V}$	$f = 120\text{ Hz}$		80	dB	
			$f = 1\text{ kHz}$		75		
			$f = 10\text{ kHz}$		60		
eN	Output noise voltage	$B = 10\text{ Hz to }100\text{ KHz}$		50		μV	
V_d	Dropout voltage	$I_O = 200\text{ mA}$		0.2	0.35	V	
		$I_O = 500\text{ mA}$		0.4	0.7		
V_{IL}	Control input logic low	$T_a = -40\text{ to }125\text{ }^\circ\text{C}$			0.8	V	
V_{IH}	Control input logic high	$T_a = -40\text{ to }125\text{ }^\circ\text{C}$	2			V	
I_I	Control input current	$V_I = 6\text{ V}$, $V_C = 6\text{ V}$		10		μA	
C_O	Output bypass capacitance	$\text{ESR} = 0.1\text{ to }10\text{ }\Omega$, $I_O = 0\text{ to }500\text{ mA}$	2	10		μF	

Refer to the test circuits, $T_J = 25\text{ }^\circ\text{C}$, $C_I = 0.1\text{ }\mu\text{F}$, $C_O = 2.2\text{ }\mu\text{F}$ unless otherwise specified.

Table 6. Electrical characteristics ($V_O = 5\text{ V}$)

Symbol	Parameter	Test conditions	Min.	Typ.	Max.	Unit
V_O	Output voltage	$I_O = 50\text{ mA}$, $V_I = 7\text{ V}$	4.9	5	5.1	V
		$I_O = 50\text{ mA}$, $V_I = 7\text{ V}$, $T_a = -25\text{ to }85^\circ\text{C}$	4.8		5.2	
V_I	Operating input voltage	$I_O = 500\text{ mA}$			20	V
I_O	Output current limit			1		A
ΔV_O	Line regulation	$V_I = 6\text{ to }20\text{ V}$, $I_O = 5\text{ mA}$		3	18	mV
ΔV_O	Load regulation	$V_I = 6.3\text{ V}$, $I_O = 5\text{ to }500\text{ mA}$		2	50	mV
I_d	Quiescent current	$V_I = 6\text{ to }20\text{ V}$, $I_O = 0\text{ mA}$	ON MODE	0.5	1	mA
		$V_I = 6.3\text{ to }20\text{ V}$, $I_O = 500\text{ mA}$			12	
		$V_I = 6\text{ V}$	OFF MODE	50	100	μA
SVR	Supply voltage rejection	$I_O = 5\text{ mA}$, $V_I = 7 \pm 1\text{ V}$	$f = 120\text{ Hz}$	76		dB
			$f = 1\text{ kHz}$	71		
			$f = 10\text{ kHz}$	60		
eN	Output noise voltage	$B = 10\text{ Hz to }100\text{ KHz}$		50		μV
V_d	Dropout voltage	$I_O = 200\text{ mA}$		0.2	0.35	V
		$I_O = 500\text{ mA}$		0.4	0.7	
V_{IL}	Control input logic low	$T_a = -40\text{ to }125^\circ\text{C}$			0.8	V
V_{IH}	Control input logic high	$T_a = -40\text{ to }125^\circ\text{C}$	2			V
I_I	Control input current	$V_I = 6\text{ V}$, $V_C = 6\text{ V}$		10		μA
C_O	Output bypass capacitance	$\text{ESR} = 0.1\text{ to }10\text{ }\Omega$, $I_O = 0\text{ to }500\text{ mA}$	2	10		μF

Refer to the test circuits, $T_J = 25\text{ }^\circ\text{C}$, $C_I = 0.1\text{ }\mu\text{F}$, $C_O = 2.2\text{ }\mu\text{F}$ unless otherwise specified.

Table 7. Electrical characteristics ($V_O = 8\text{ V}$)

Symbol	Parameter	Test conditions	Min.	Typ.	Max.	Unit
V_O	Output voltage	$I_O = 50\text{ mA}$, $V_I = 10\text{ V}$	7.84	8	8.16	V
		$I_O = 50\text{ mA}$, $V_I = 10\text{ V}$, $T_a = -25\text{ to }85\text{ }^\circ\text{C}$	7.68		8.32	
V_I	Operating input voltage	$I_O = 500\text{ mA}$			20	V
I_O	Output current limit			1		A
ΔV_O	Line regulation	$V_I = 9\text{ to }20\text{ V}$, $I_O = 5\text{ mA}$		4	24	mV
ΔV_O	Load regulation	$V_I = 9.3\text{ V}$, $I_O = 5\text{ to }500\text{ mA}$		2	50	mV
I_d	Quiescent current	$V_I = 9\text{ to }20\text{ V}$, $I_O = 0\text{ mA}$	ON MODE	0.7	1.5	mA
		$V_I = 9.3\text{ to }20\text{ V}$, $I_O = 500\text{ mA}$			12	
		$V_I = 9\text{ V}$	OFF MODE	70	140	μA
SVR	Supply voltage rejection	$I_O = 5\text{ mA}$, $V_I = 10 \pm 1\text{ V}$	$f = 120\text{ Hz}$	72		dB
			$f = 1\text{ kHz}$	67		
			$f = 10\text{ kHz}$	60		
eN	Output noise voltage	$B = 10\text{ Hz to }100\text{ KHz}$		50		μV
V_d	Dropout voltage	$I_O = 200\text{ mA}$		0.2	0.35	V
		$I_O = 500\text{ mA}$		0.4	0.7	
V_{IL}	Control input logic low	$T_a = -40\text{ to }125\text{ }^\circ\text{C}$			0.8	V
V_{IH}	Control input logic high	$T_a = -40\text{ to }125\text{ }^\circ\text{C}$	2			V
I_I	Control input current	$V_I = 6\text{ V}$, $V_C = 6\text{ V}$		10		μA
C_O	Output bypass capacitance	$\text{ESR} = 0.1\text{ to }10\text{ }\Omega$, $I_O = 0\text{ to }500\text{ mA}$	2	10		μF

5 Typical performance characteristics

Unless otherwise specified $V_{O(NOM)} = 3.3\text{ V}$.

Figure 4. Dropout voltage vs. output current

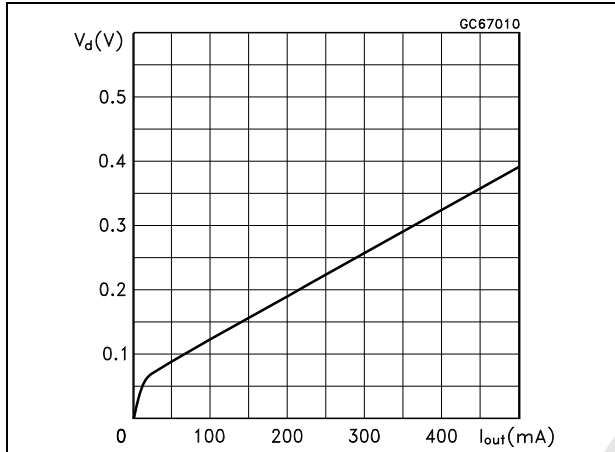

Figure 5. Dropout voltage vs. temperature

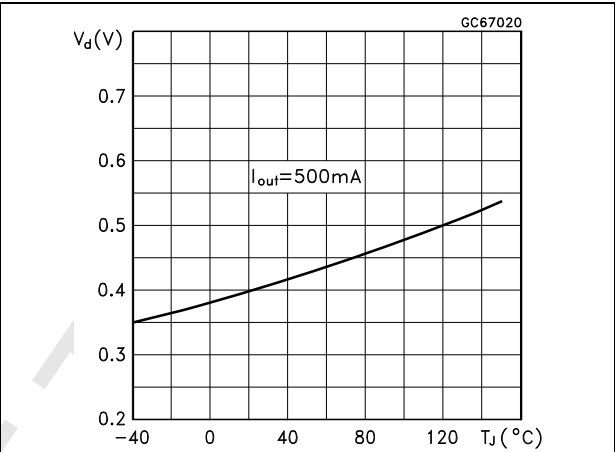

Figure 6. Supply current vs. input voltage ($I_{OUT} = 500\text{ mA}$)

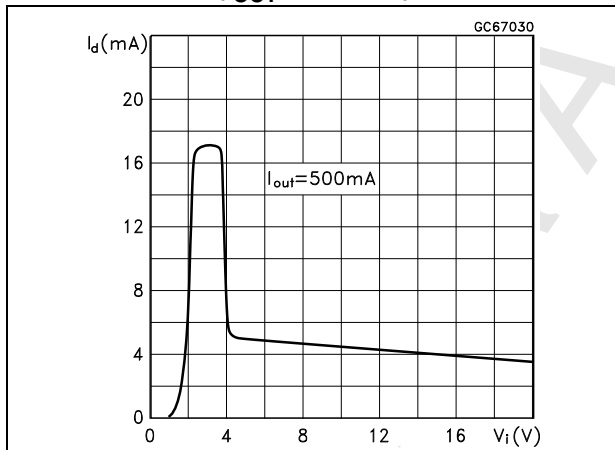

Figure 7. Supply current vs. input voltage ($I_{OUT} = 0\text{ mA}$)

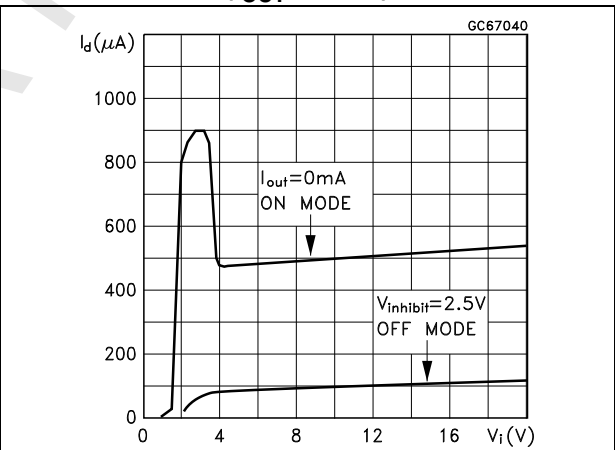

Figure 8. Short circuit current vs. input voltage

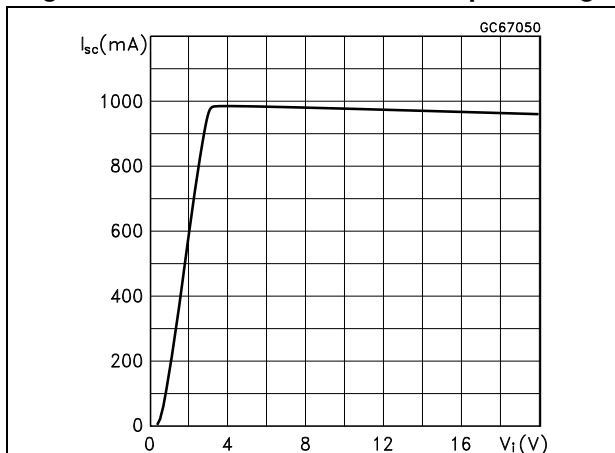
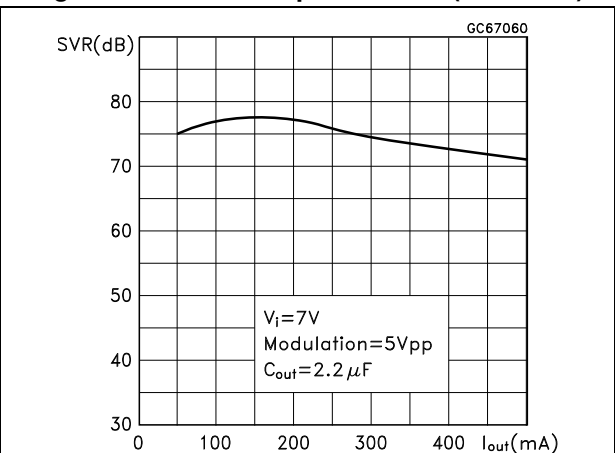

Figure 9. SVR vs. output current (f= 120 Hz)



6 Package mechanical data

In order to meet environmental requirements, ST offers these devices in different grades of ECOPACK® packages, depending on their level of environmental compliance. ECOPACK® specifications, grade definitions and product status are available at: www.st.com. ECOPACK® is an ST trademark.

DRAFT

Figure 10. DPAK (TO-252) type A drawing

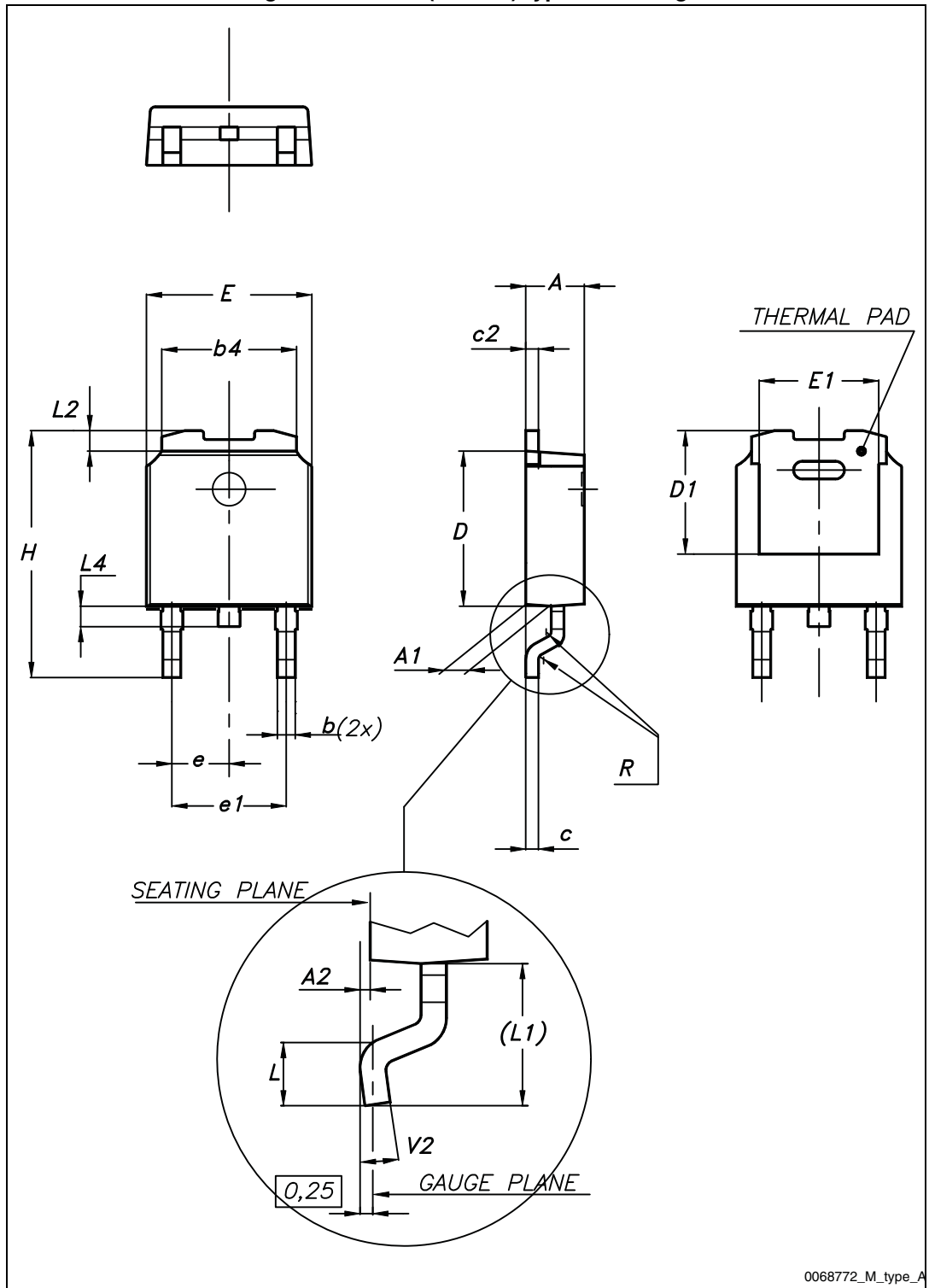

0068772_M_type_A

Table 8. DPAK (TO-252) type A mechanical data

Dim.	mm		
	Min.	Typ.	Max.
A	2.20		2.40
A1	0.90		1.10
A2	0.03		0.23
b	0.64		0.90
b4	5.20		5.40
c	0.45		0.60
c2	0.48		0.60
D	6.00		6.20
D1		5.10	
E	6.40		6.60
E1		4.70	
e		2.28	
e1	4.40		4.60
H	9.35		10.10
L	1.00		1.50
(L1)		2.80	
L2		0.80	
L4	0.60		1.00
R		0.20	
V2	0°		8°

Figure 11. DPAK (TO-252) type A footprint (a)

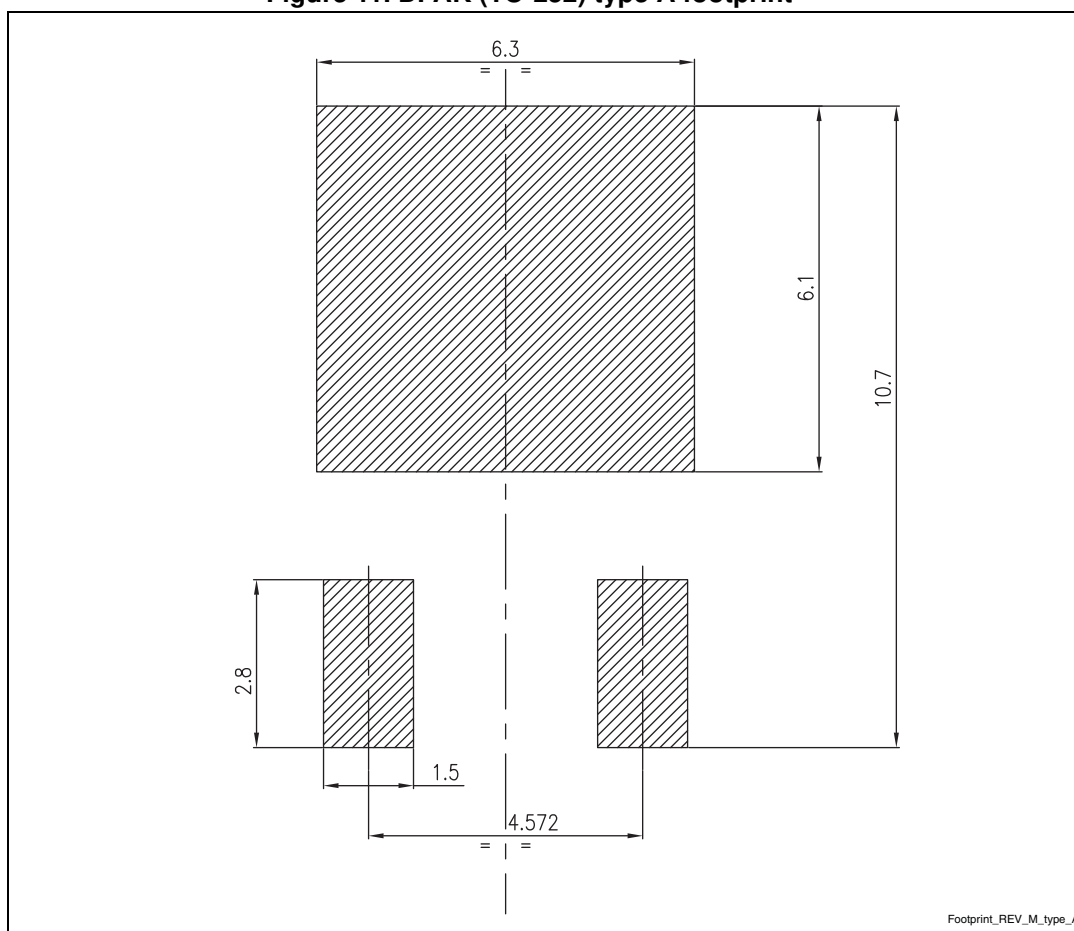

a. All dimensions are in millimeters

Figure 12. SO-8 drawing

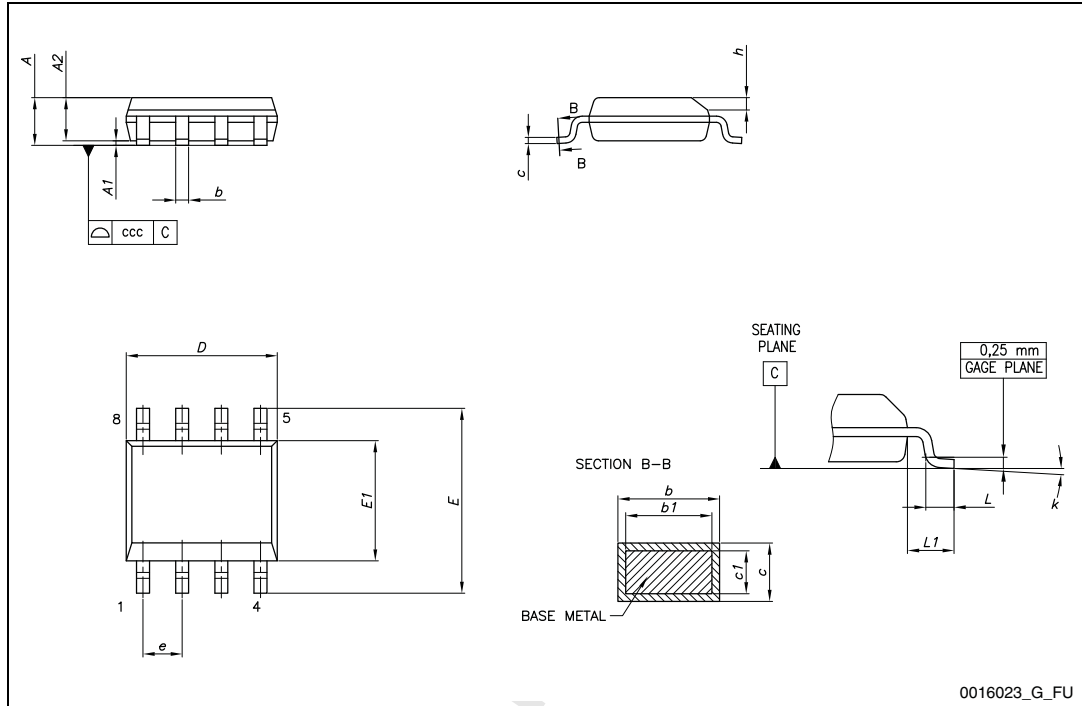

0016023_G_FU

Table 9. SO-8 mechanical data

Dim.	mm		
	Min.	Typ.	Max.
A			1.75
A1	0.10		0.25
A2	1.25		
b	0.31		0.51
b1	0.28		0.48
c	0.10		0.25
c1	0.10		0.23
D	4.80	4.90	5.00
E	5.80	6.00	6.20
E1	3.80	3.90	4.00
e		1.27	
h	0.25		0.50
L	0.40		1.27
L1		1.04	
L2		0.25	

Table 9. SO-8 mechanical data (continued)

Dim.	mm		
	Min.	Typ.	Max.
k	0°		8°
ccc			0.10

Figure 13. SO-8 recommended footprint^(b)

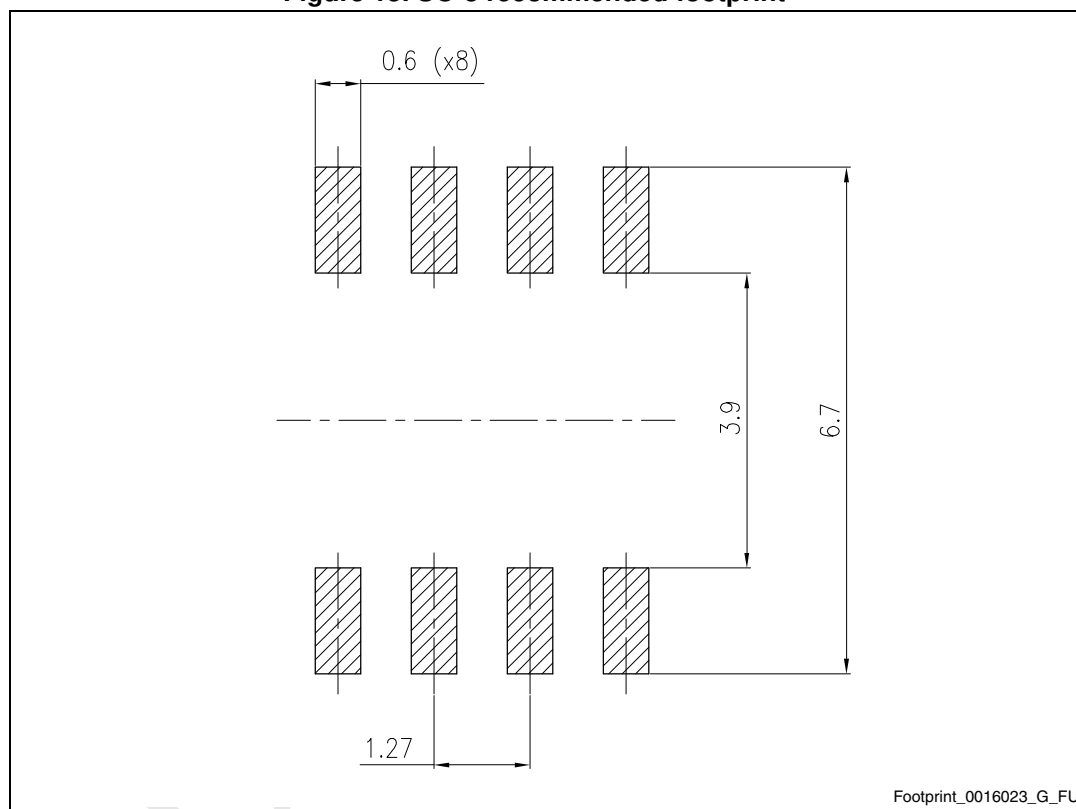

Footprint_0016023_G_FU

b. All dimensions are in millimeters.

7 Packaging mechanical data

Figure 14. Tape for DPAK (TO-252)

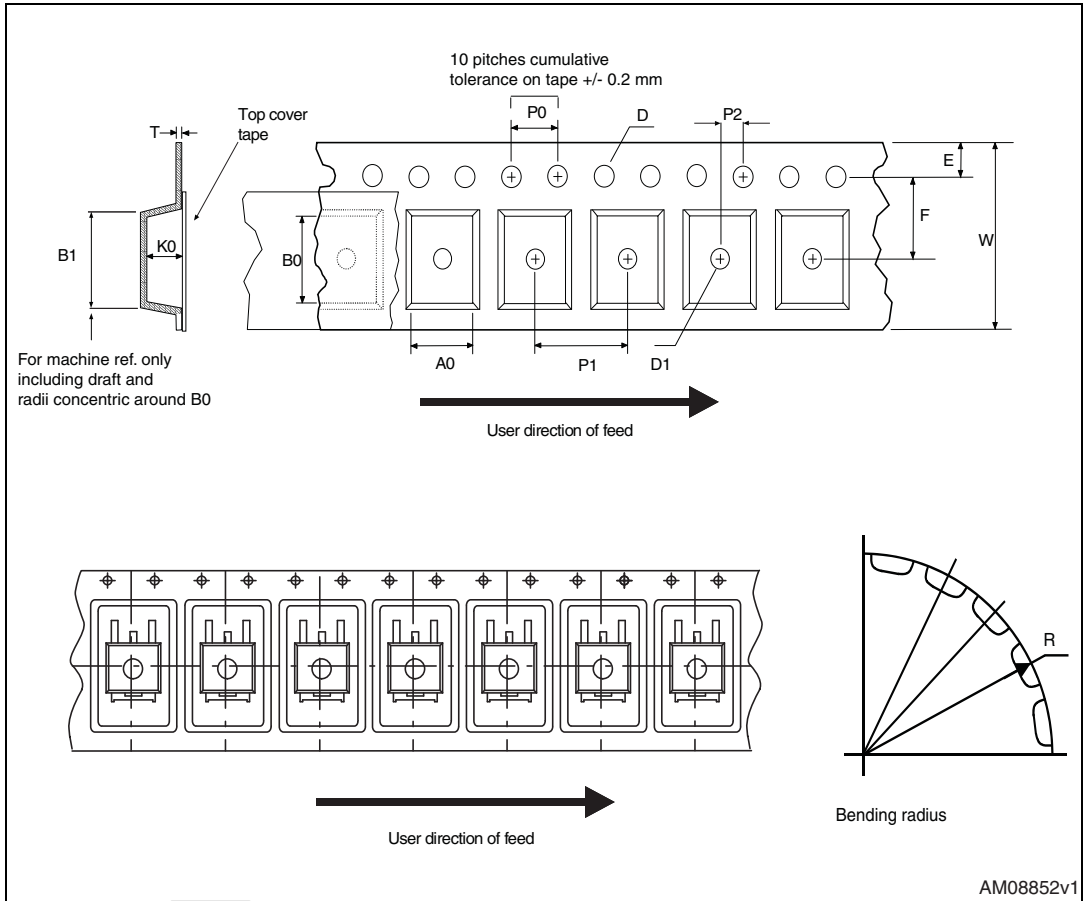

Figure 15. Reel for DPAK (TO-252)

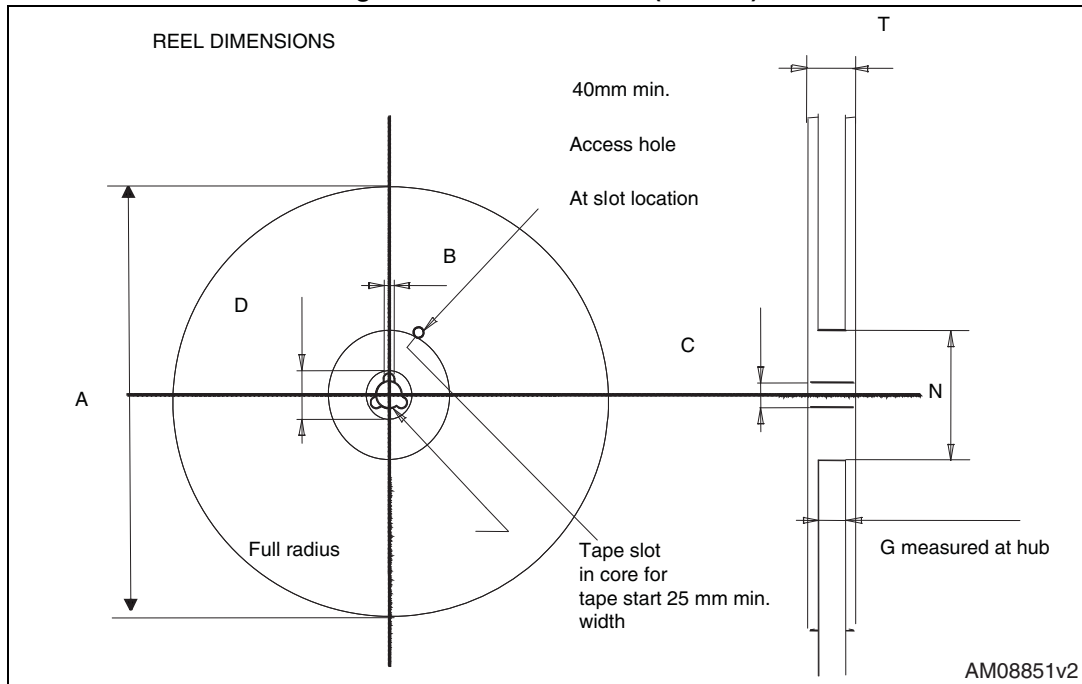

Table 10. DPAK (TO-252) tape and reel mechanical data

Tape			Reel		
Dim.	mm		Dim.	mm	
	Min.	Max.		Min.	Max.
A0	6.8	7	A		330
B0	10.4	10.6	B	1.5	
B1		12.1	C	12.8	13.2
D	1.5	1.6	D	20.2	
D1	1.5		G	16.4	18.4
E	1.65	1.85	N	50	
F	7.4	7.6	T		22.4
K0	2.55	2.75			
P0	3.9	4.1		Base qty.	2500
P1	7.9	8.1		Bulk qty.	2500
P2	1.9	2.1			
R	40				
T	0.25	0.35			
W	15.7	16.3			

Figure 16. SO-8 tape and reel dimensions

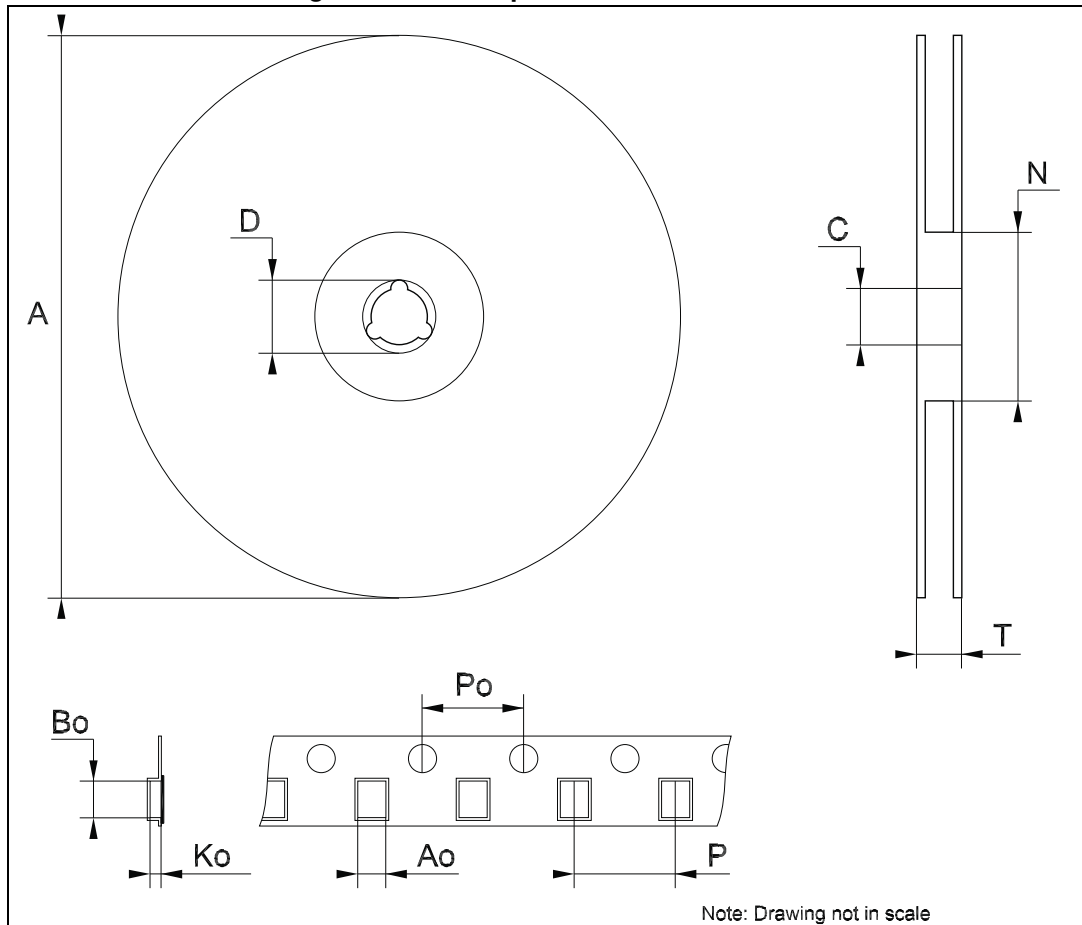

Table 11. SO-8 tape and reel mechanical data

Dim.	mm		
	Min.	Typ.	Max.
A			330
C	12.8		13.2
D	20.2		
N	60		
T			22.4
Ao	8.1		8.5
Bo	5.5		5.9
Ko	2.1		2.3
Po	3.9		4.1
P	7.9		8.1

8 Revision history

Table 12. Document revision history

Date	Revision	Changes
06-Jun-2007	9	Order codes updated.
14-Dec-2007	10	Modified: Table 1 .
21-Feb-2008	11	Modified: Table 1 .
23-Oct-2012	12	Change title description in cover page. Updated: Table 1 on page 1 . Added: R_{thJA} value for DPAK and SO-8 Table 3 on page 5 . Modified: titles Figure 6 and Figure 7 on page 10 .
19-Mar-2014	13	The part numbers KF25B, KF33B, KF50B, KF80B changed to KF. Updated Section 6: Package mechanical data and Section 7: Packaging mechanical data . Minor text changes.

Please Read Carefully:

Information in this document is provided solely in connection with ST products. STMicroelectronics NV and its subsidiaries ("ST") reserve the right to make changes, corrections, modifications or improvements, to this document, and the products and services described herein at any time, without notice.

All ST products are sold pursuant to ST's terms and conditions of sale.

Purchasers are solely responsible for the choice, selection and use of the ST products and services described herein, and ST assumes no liability whatsoever relating to the choice, selection or use of the ST products and services described herein.

No license, express or implied, by estoppel or otherwise, to any intellectual property rights is granted under this document. If any part of this document refers to any third party products or services it shall not be deemed a license grant by ST for the use of such third party products or services, or any intellectual property contained therein or considered as a warranty covering the use in any manner whatsoever of such third party products or services or any intellectual property contained therein.

UNLESS OTHERWISE SET FORTH IN ST'S TERMS AND CONDITIONS OF SALE ST DISCLAIMS ANY EXPRESS OR IMPLIED WARRANTY WITH RESPECT TO THE USE AND/OR SALE OF ST PRODUCTS INCLUDING WITHOUT LIMITATION IMPLIED WARRANTIES OF MERCHANTABILITY, FITNESS FOR A PARTICULAR PURPOSE (AND THEIR EQUIVALENTS UNDER THE LAWS OF ANY JURISDICTION), OR INFRINGEMENT OF ANY PATENT, COPYRIGHT OR OTHER INTELLECTUAL PROPERTY RIGHT.

ST PRODUCTS ARE NOT DESIGNED OR AUTHORIZED FOR USE IN: (A) SAFETY CRITICAL APPLICATIONS SUCH AS LIFE SUPPORTING, ACTIVE IMPLANTED DEVICES OR SYSTEMS WITH PRODUCT FUNCTIONAL SAFETY REQUIREMENTS; (B) AERONAUTIC APPLICATIONS; (C) AUTOMOTIVE APPLICATIONS OR ENVIRONMENTS, AND/OR (D) AEROSPACE APPLICATIONS OR ENVIRONMENTS. WHERE ST PRODUCTS ARE NOT DESIGNED FOR SUCH USE, THE PURCHASER SHALL USE PRODUCTS AT PURCHASER'S SOLE RISK, EVEN IF ST HAS BEEN INFORMED IN WRITING OF SUCH USAGE, UNLESS A PRODUCT IS EXPRESSLY DESIGNATED BY ST AS BEING INTENDED FOR "AUTOMOTIVE, AUTOMOTIVE SAFETY OR MEDICAL" INDUSTRY DOMAINS ACCORDING TO ST PRODUCT DESIGN SPECIFICATIONS. PRODUCTS FORMALLY ESCC, QML OR JAN QUALIFIED ARE DEEMED SUITABLE FOR USE IN AEROSPACE BY THE CORRESPONDING GOVERNMENTAL AGENCY.

Resale of ST products with provisions different from the statements and/or technical features set forth in this document shall immediately void any warranty granted by ST for the ST product or service described herein and shall not create or extend in any manner whatsoever, any liability of ST.

ST and the ST logo are trademarks or registered trademarks of ST in various countries.

Information in this document supersedes and replaces all information previously supplied.

The ST logo is a registered trademark of STMicroelectronics. All other names are the property of their respective owners.

© 2014 STMicroelectronics - All rights reserved

STMicroelectronics group of companies

Australia - Belgium - Brazil - Canada - China - Czech Republic - Finland - France - Germany - Hong Kong - India - Israel - Italy - Japan - Malaysia - Malta - Morocco - Philippines - Singapore - Spain - Sweden - Switzerland - United Kingdom - United States of America

www.st.com

