



Chipsmall Limited consists of a professional team with an average of over 10 year of expertise in the distribution of electronic components. Based in Hongkong, we have already established firm and mutual-benefit business relationships with customers from,Europe,America and south Asia,supplying obsolete and hard-to-find components to meet their specific needs.

With the principle of “Quality Parts,Customers Priority,Honest Operation,and Considerate Service”,our business mainly focus on the distribution of electronic components. Line cards we deal with include Microchip,ALPS,ROHM,Xilinx,Pulse,ON,Everlight and Freescale. Main products comprise IC,Modules,Potentiometer,IC Socket,Relay,Connector.Our parts cover such applications as commercial,industrial, and automotives areas.

We are looking forward to setting up business relationship with you and hope to provide you with the best service and solution. Let us make a better world for our industry!



## Contact us

Tel: +86-755-8981 8866 Fax: +86-755-8427 6832

Email & Skype: info@chipsmall.com Web: www.chipsmall.com

Address: A1208, Overseas Decoration Building, #122 Zhenhua RD., Futian, Shenzhen, China



pi-top

INSTRUCTION  
MANUAL



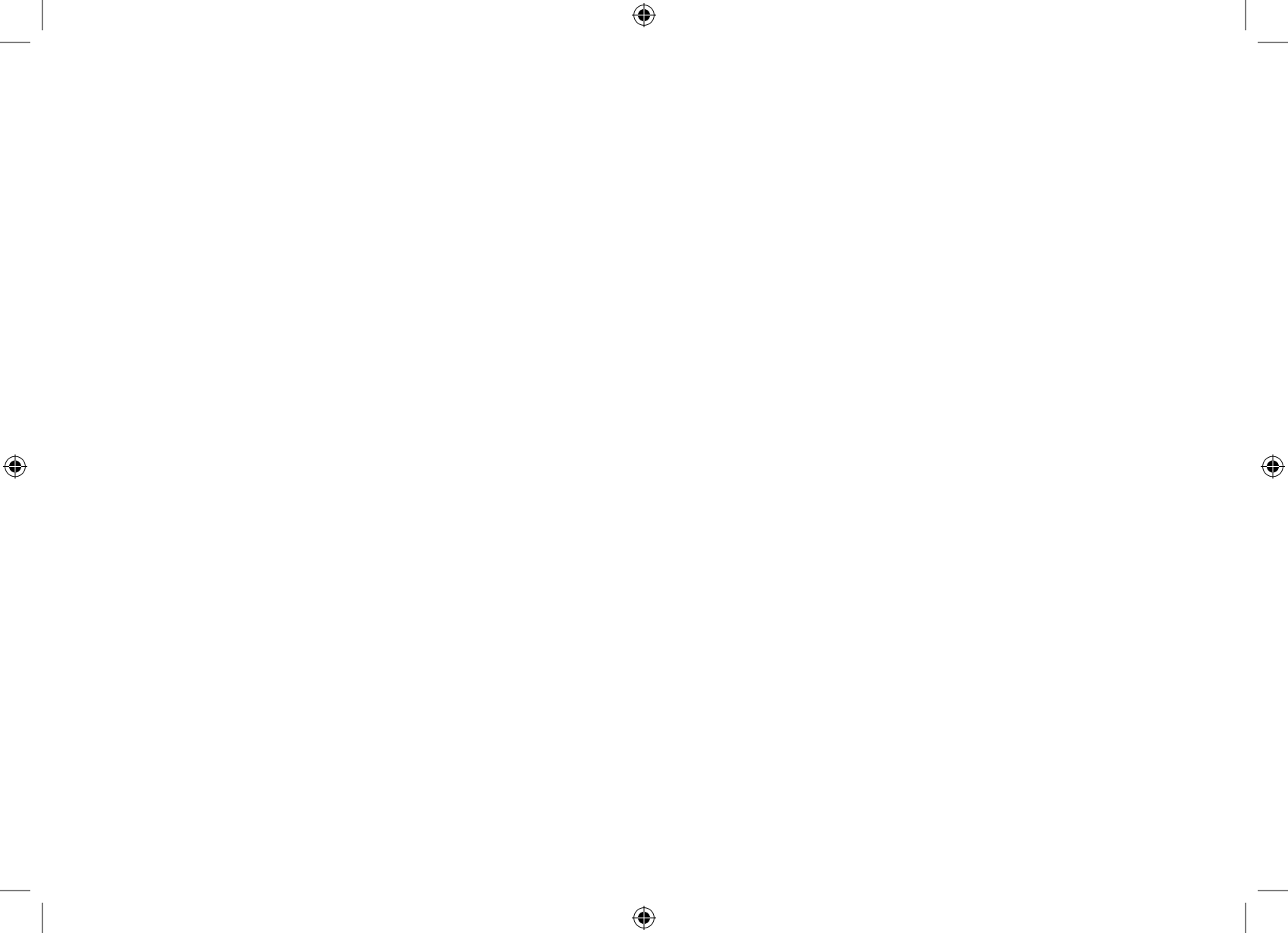

# Welcome

Welcome to the **pi-top** family!

**pi-top** is very special to us (and so are you, of course!).

We are hugely passionate about this product and are thrilled to provide excellent content so you can learn to make anything. Your support has helped to make this a reality and we thank you for joining us on this exciting maker journey!

We believe **pi-top** is the best way to get started with hardware and software. Open up your box and immediately immerse yourself in a new way of exploring computing - unlocking a world of possibilities. As you grow and learn, **pi-top** will be part of your journey to expand your knowledge - the only limit is your imagination!

So, let's get started! We've kept the manual simple, with a focus on easy image-based instructions. After assembly you can immediately log-in and start your own cool projects, play our educational game **CEED**universe and more!

Step through the world's gateway to technology.

With love,

The **pi-top** Team

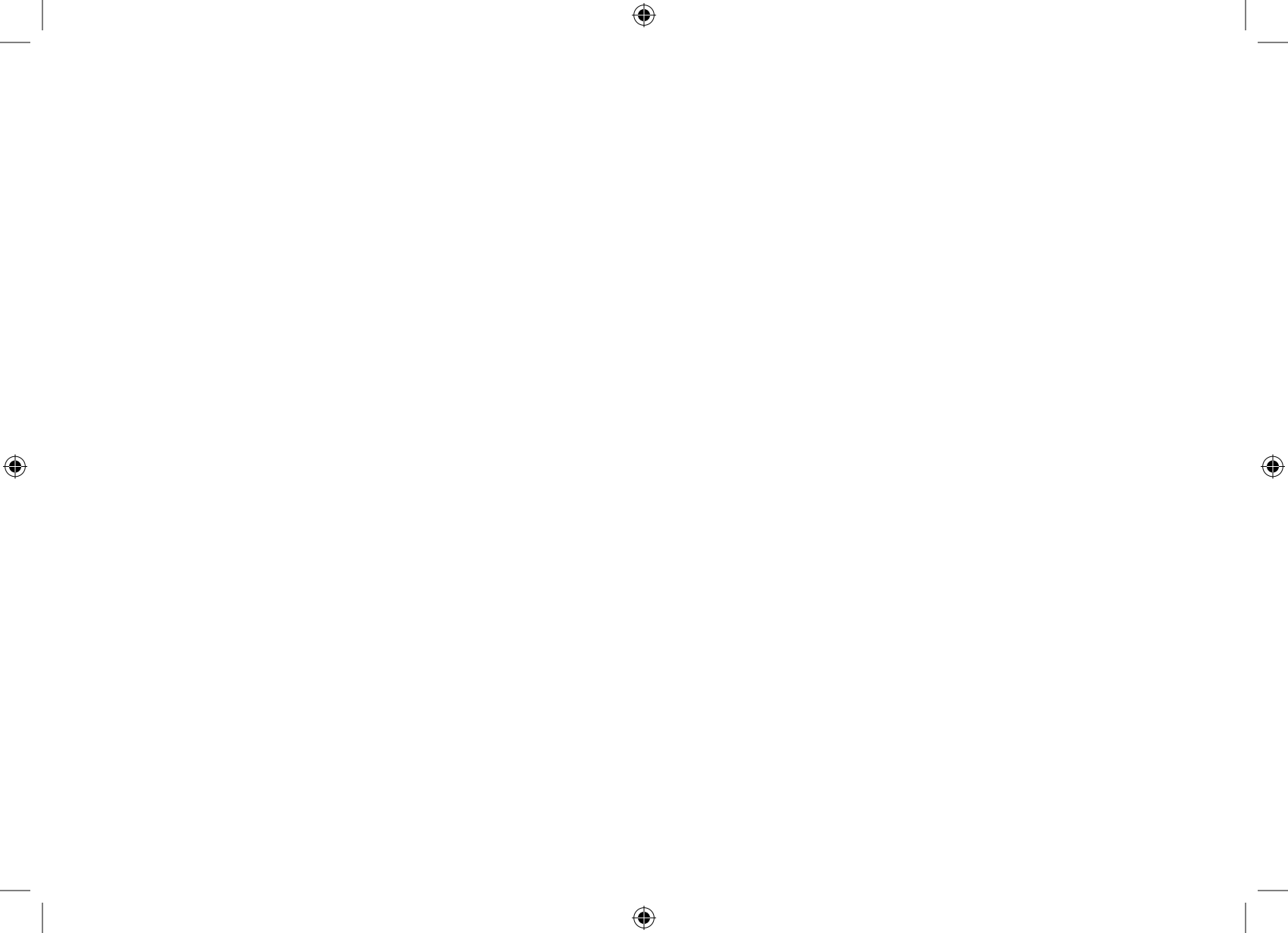

# Contents

2	Getting Ready
5	Step 1: Prepare PCBs
6	Step 2: Prepare Base
7	Step 3: Attach Lid
12	Step 4: Secure Hub
17	Step 5: Install Micro Computer
18	Step 6: Plug in Cables
20	Step 7: Prepare Base Top
22	Step 8: Attach Base Top
29	Using your <b>pi-top</b>

## Getting Ready: What's in the Box?

LID

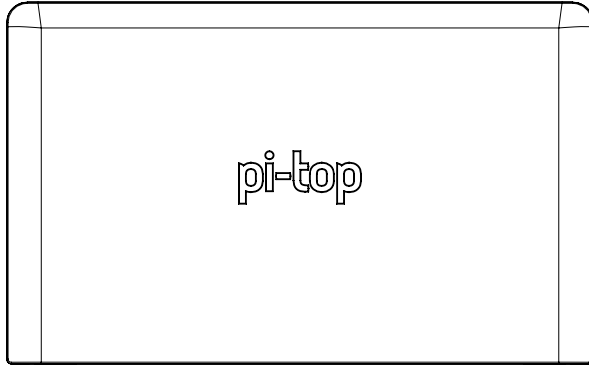

\*BASE

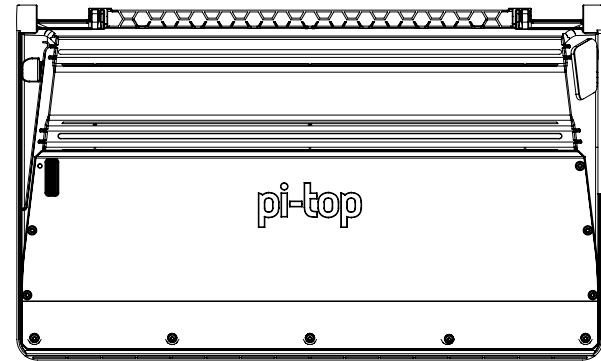

BASE TOP

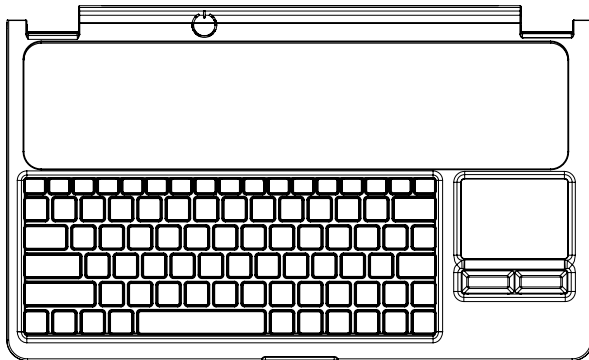

ACRYLIC SLICE



\*Warning: Base houses pi-top's Smart Battery Pack which contains lithium polymer cells – handle with great care.

# Getting Ready: What's in the Box?

HUB

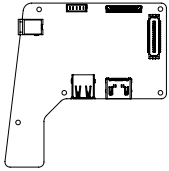

MICRO COMPUTER

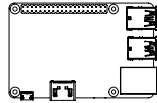

HDMI CABLE



MICRO USB CABLE

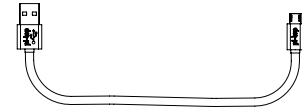

GPIO BREAKOUT CABLE



POWER CONTROL CABLE



KEYBOARD CABLE

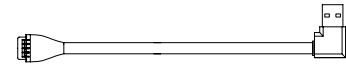

\*PCB SCREWS X8  
(Silver)



\*PCB SPACERS X8  
(Brass)



\*M2.5 NUTS X9



\*SML ALLEN KEY

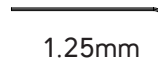

1.25mm

\*LRG ALLEN KEY



2mm

\*MICRO SD CARD



AC TO DC ADAPTER

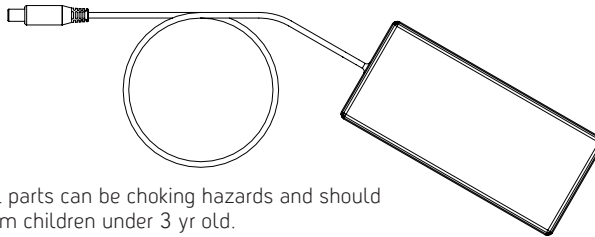

MAINS AC CABLE

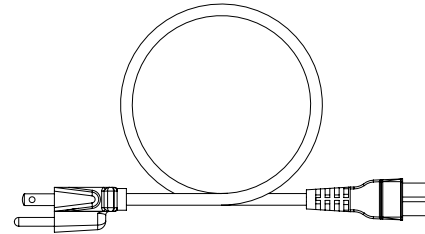

\*Warning: Small parts can be choking hazards and should be kept away from children under 3 yr old.



# Step 1.1: Prepare PCBs

## YOU WILL NEED

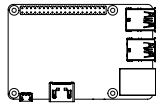
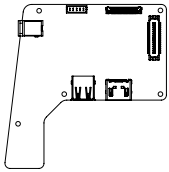

PCB SPACER  
(Brass)

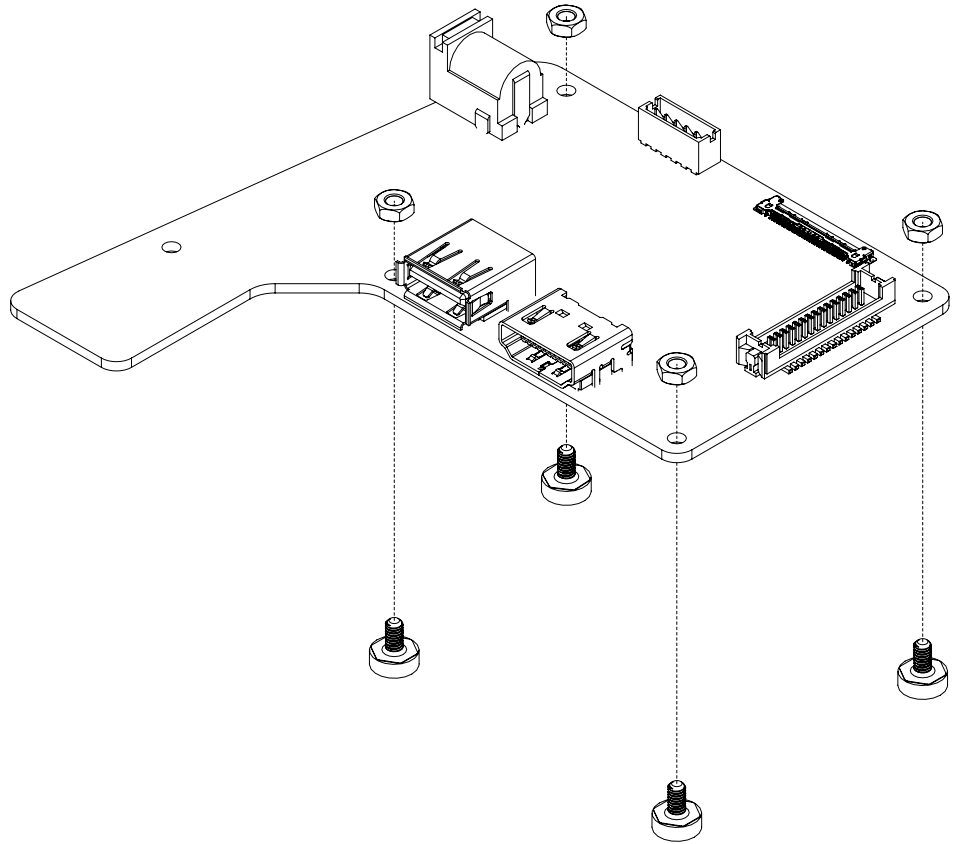

**Caution:** Be sure to work on a surface free of static electricity.

## Step 1.2: Prepare PCBs

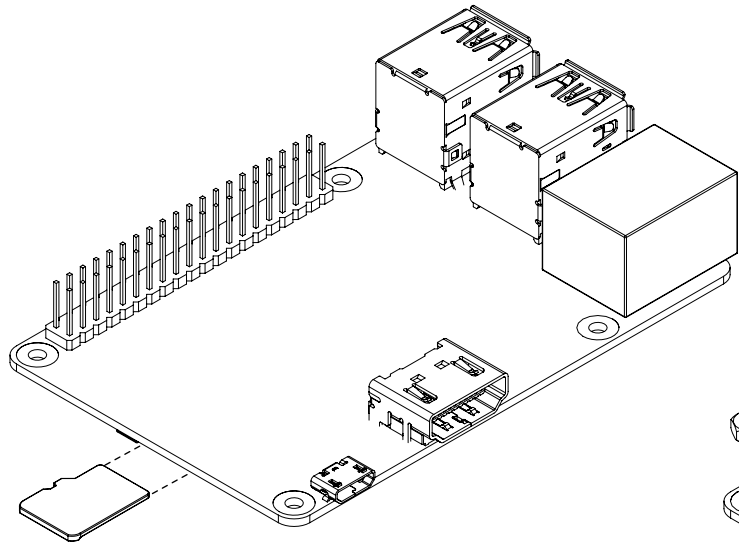

Insert micro SD Card into slot  
underneath your Micro Computer

Remove the micro SD Card  
from the adapter.

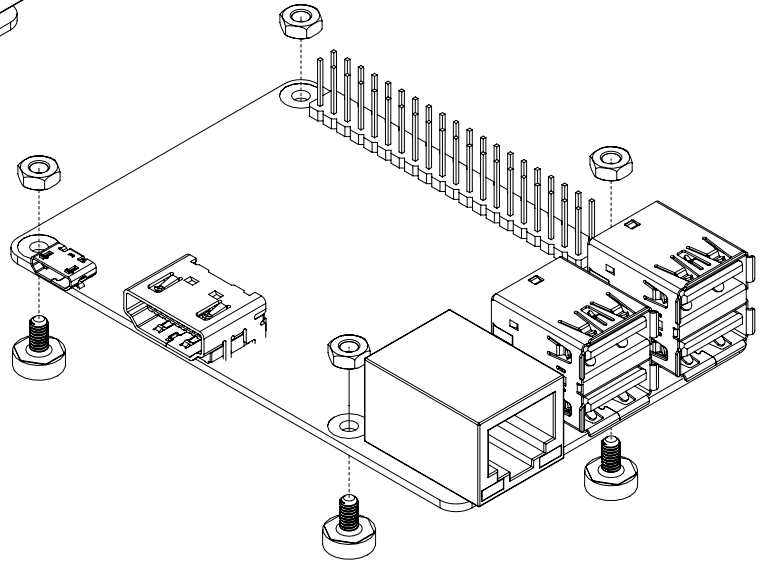
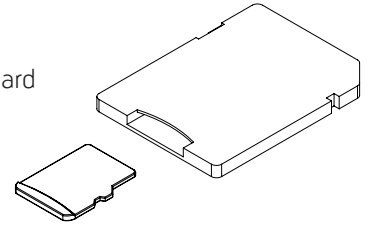

**Caution:** Keep spacers and nuts away from PCB tracks and components to avoid damaging PCB

## Step 2: Prepare Base

YOU WILL NEED

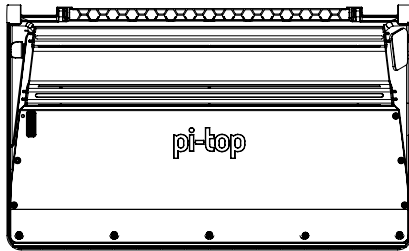

1.25mm

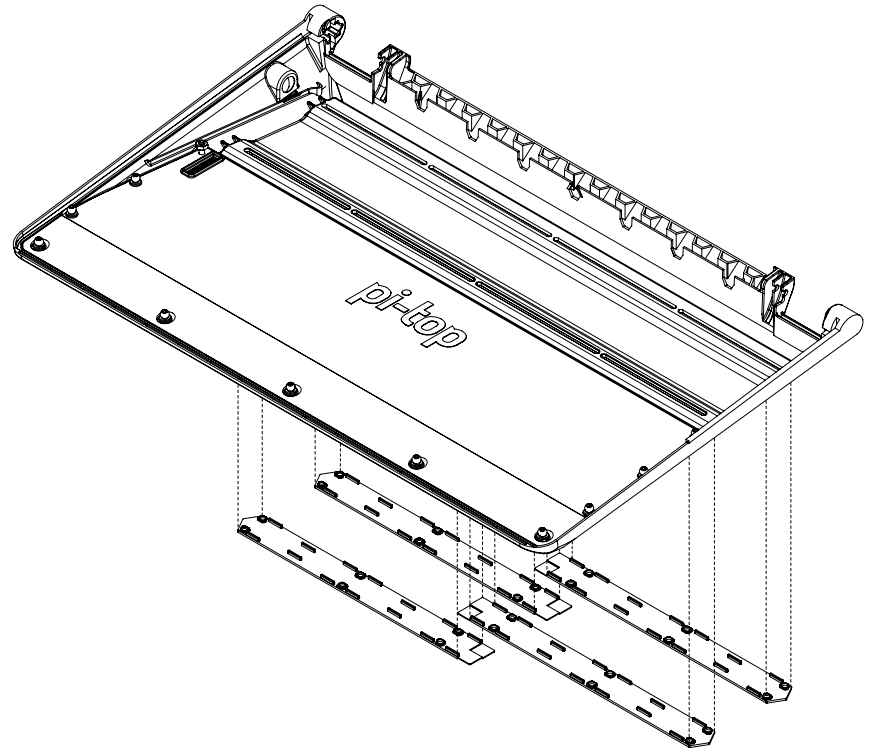

Remove Rail Covers from bottom of the Base. They can be gently pushed out from inside Base using the Small Allen Key. They are magnetically attached and you can re-attach them after you finish the whole assembly to keep your **pi-top** looking neat.

## YOU WILL NEED

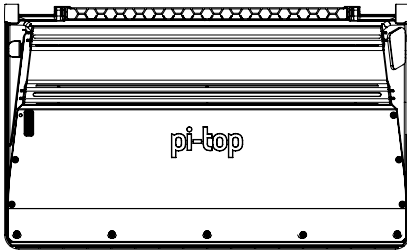
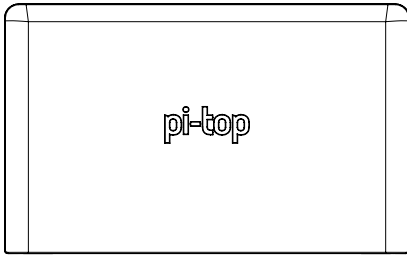

1.25mm

## Step 3.1: Attach Lid

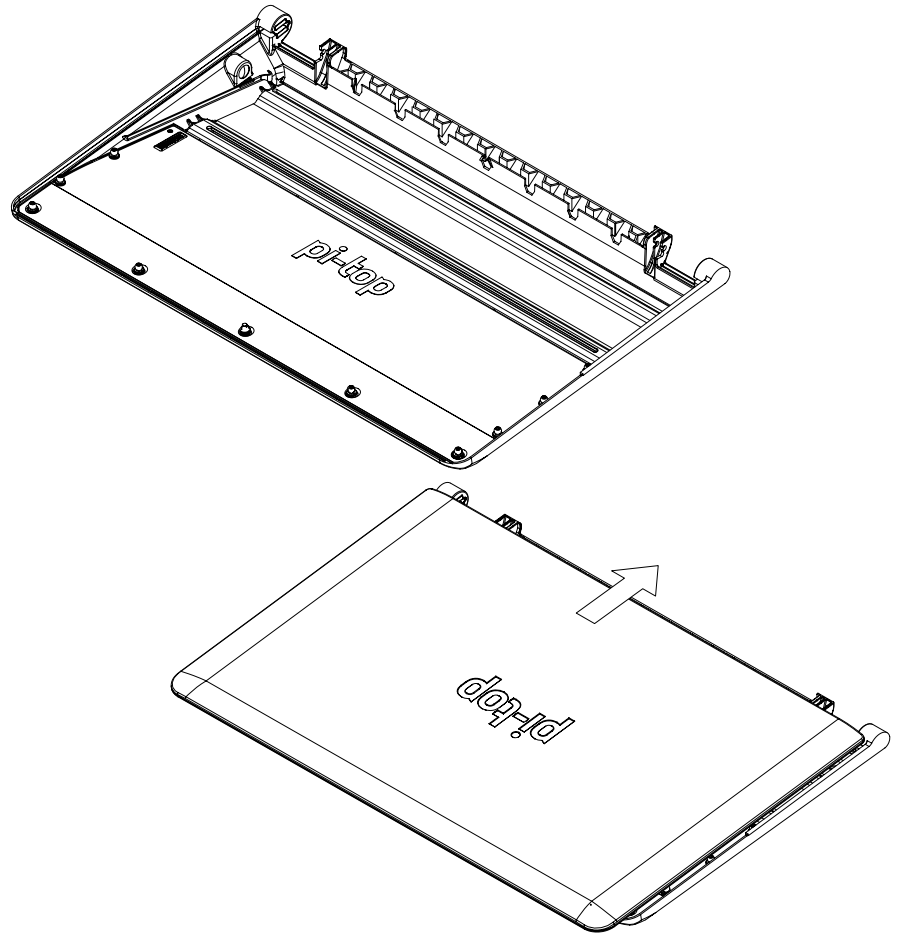

## Step 3.2: Attach Lid

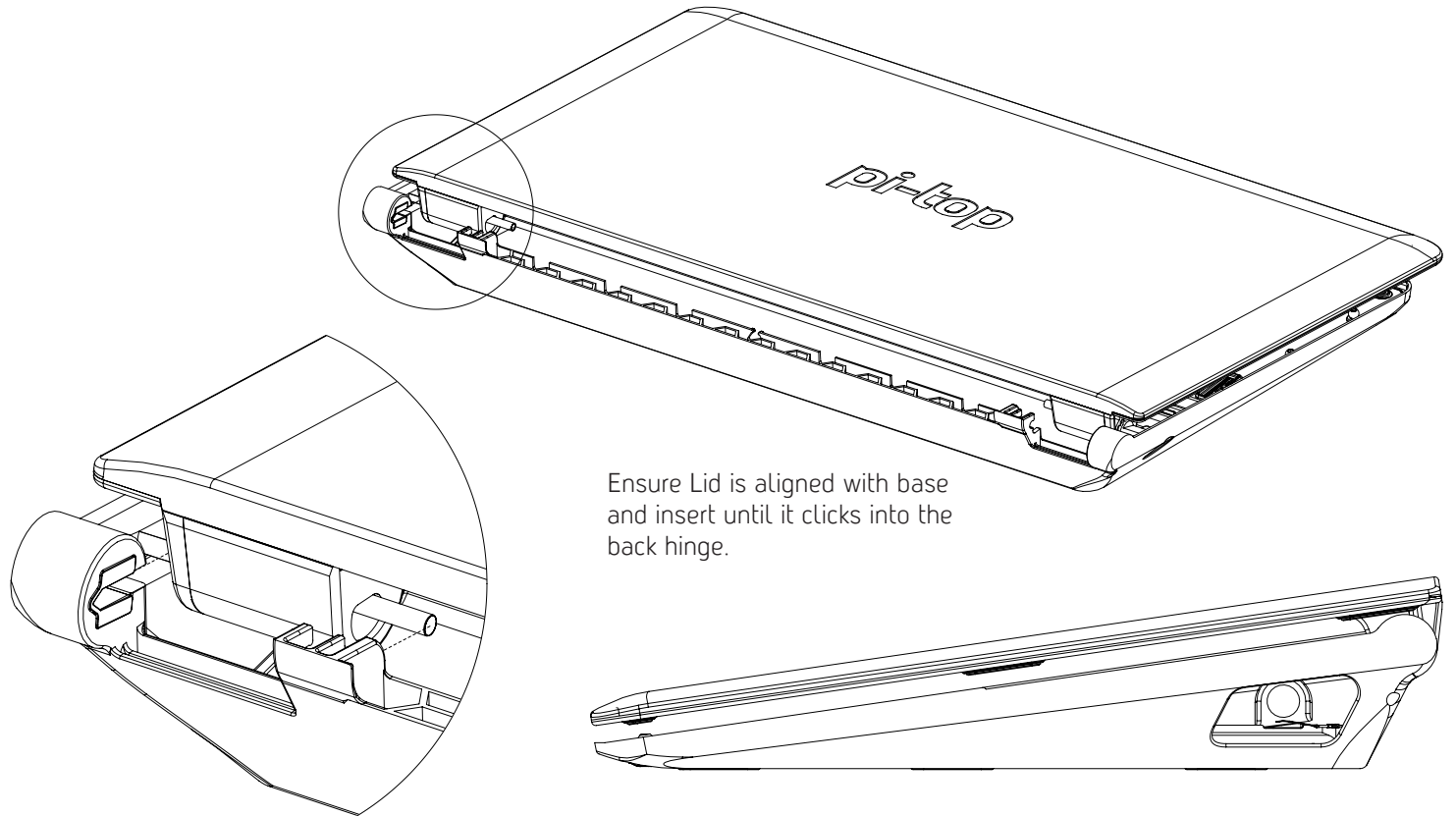

**Caution:** Ensure hinge is fully inserted. Failure to do so could lead to damage of the hinge or base.

### Step 3.3: Attach Lid

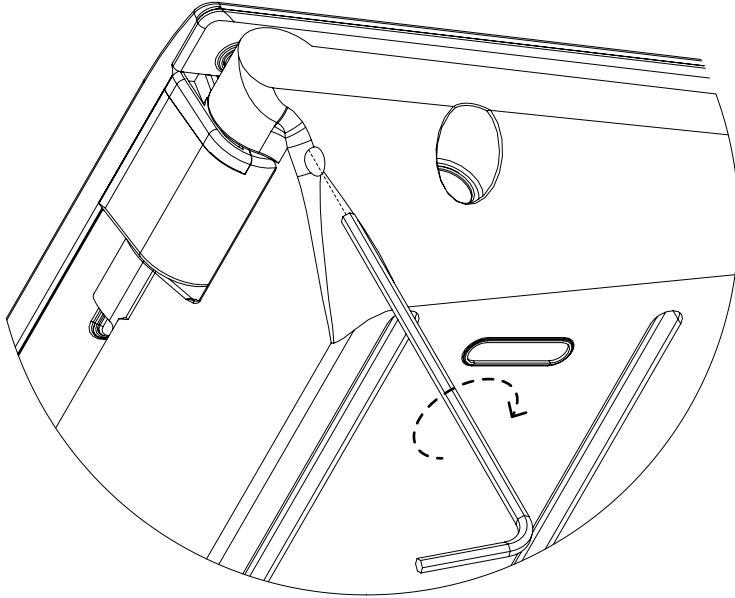

Keep the Lid aligned as you gently tighten screw.

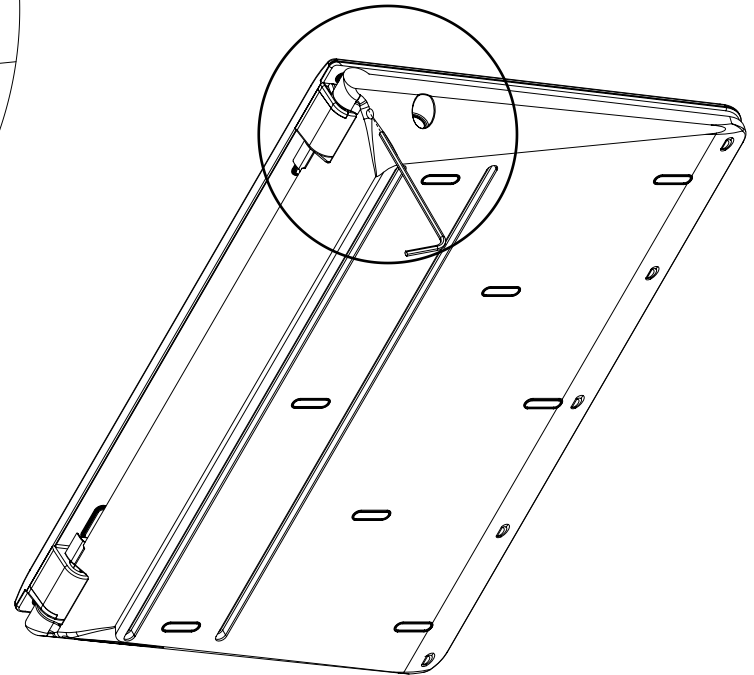

**Caution:** Do not over tighten to avoid damaging screw head.

## Step 3.4: Attach Lid

Before opening please make sure the hinge is fully inserted and secured in place.

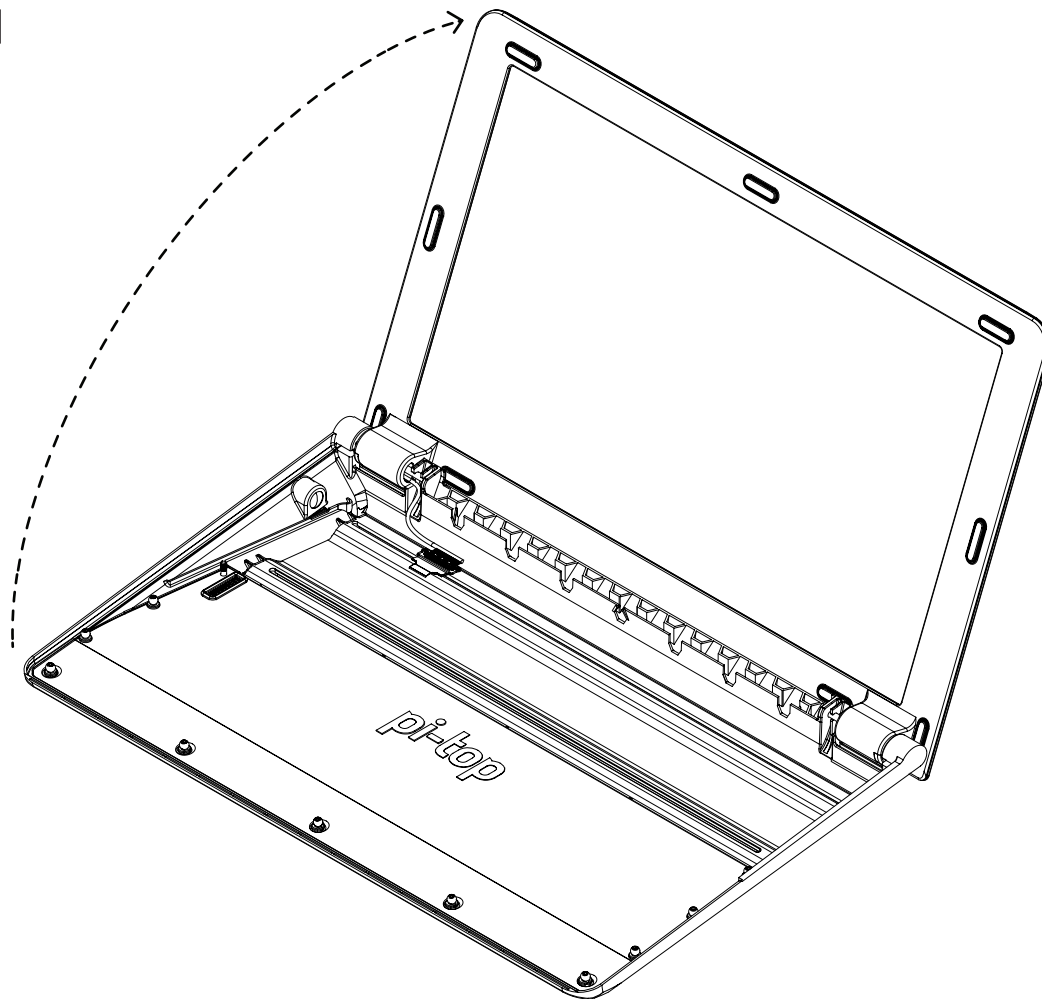

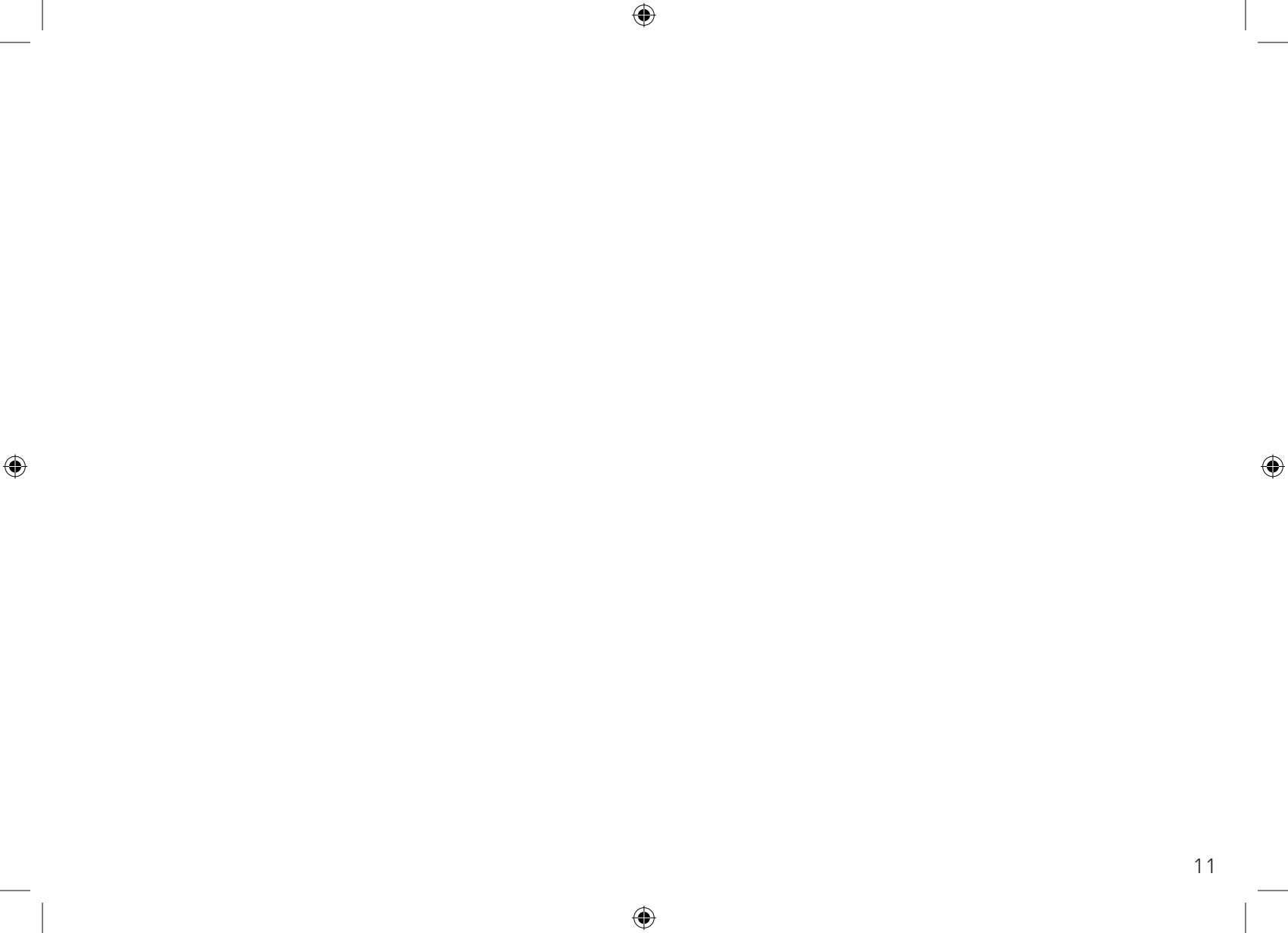



## Step 4.1: Secure Hub

### YOU WILL NEED

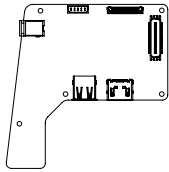

PCB SCREW  
(Silver)



We recommend that you connect the screen cable before you insert the Hub as it's easier this way.

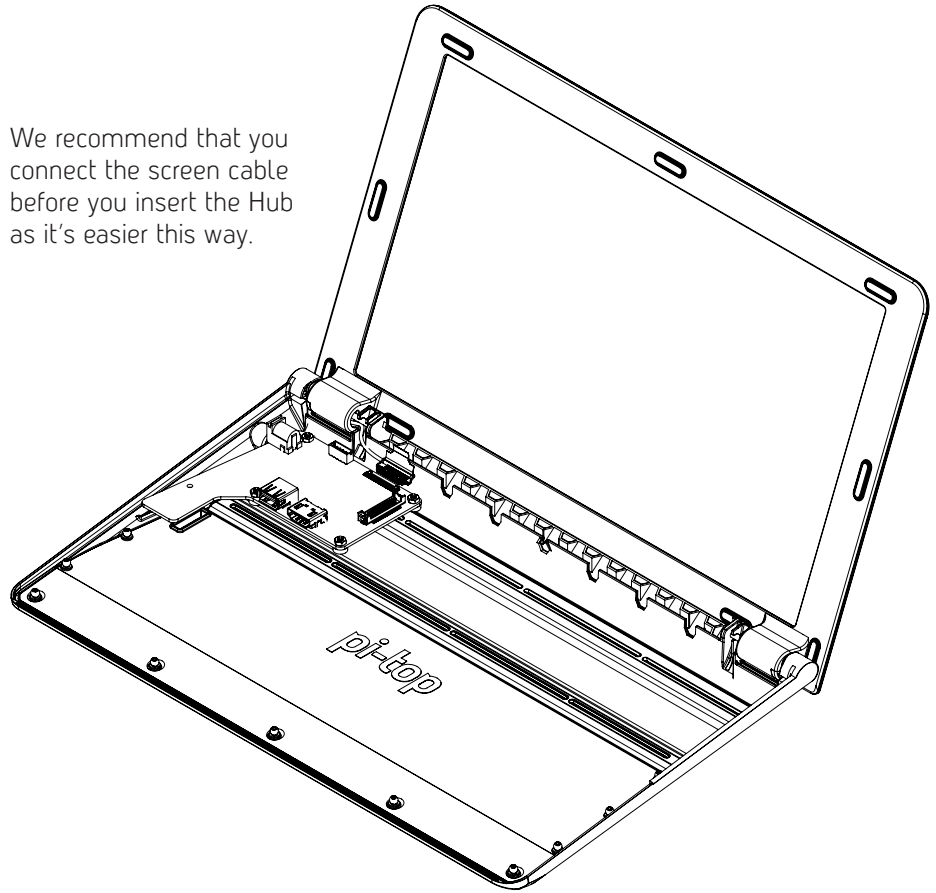

**Caution:** Ensure battery connector on Hub doesn't make contact with battery until Step 4-3.

## Step 4.2: Secure Hub

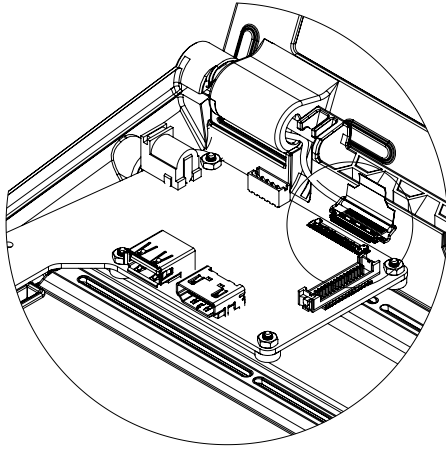

Align and insert

Rotate locking bar

Gently push down on both sides until it clicks and is secured

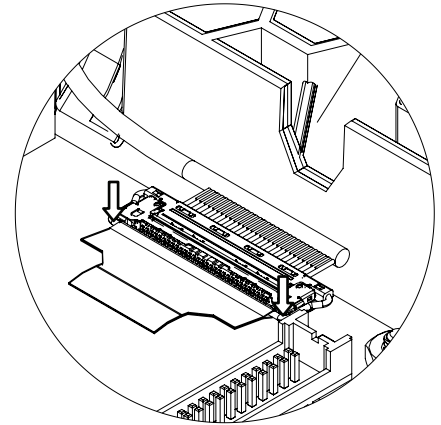
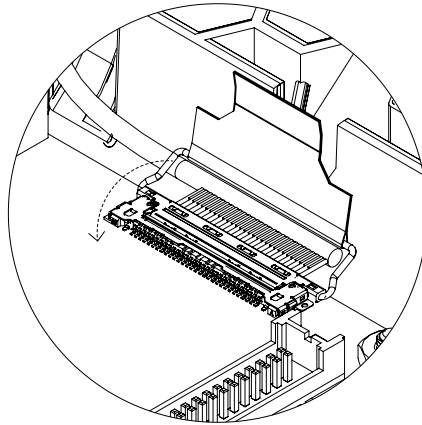
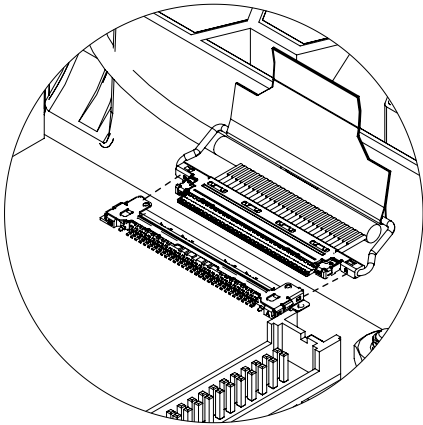

**Caution:** Take extra care to properly align and do not use excessive force.

## Step 4.3: Secure Hub

We recommend putting it on this spigot as it's easier this way!

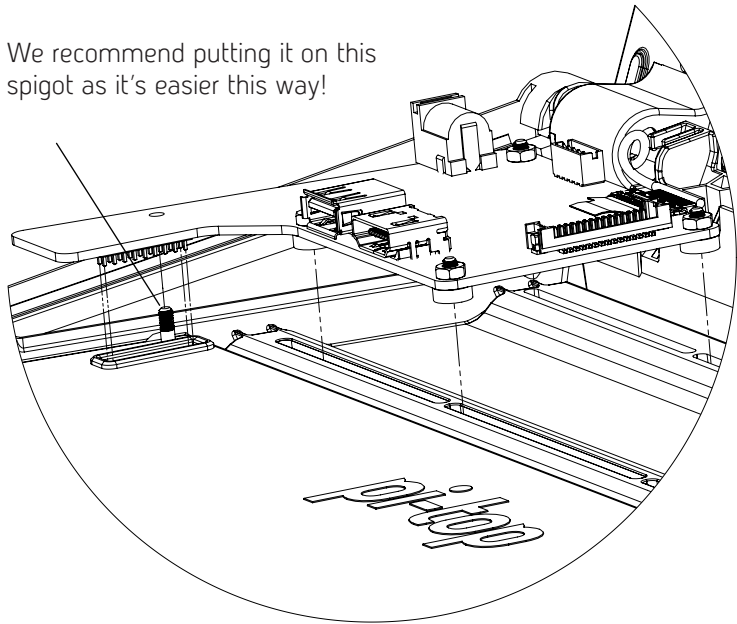

While keeping the left-side of the Hub aligned to the Base, press down on the battery symbol on the Hub until you feel the connector insert fully into battery.

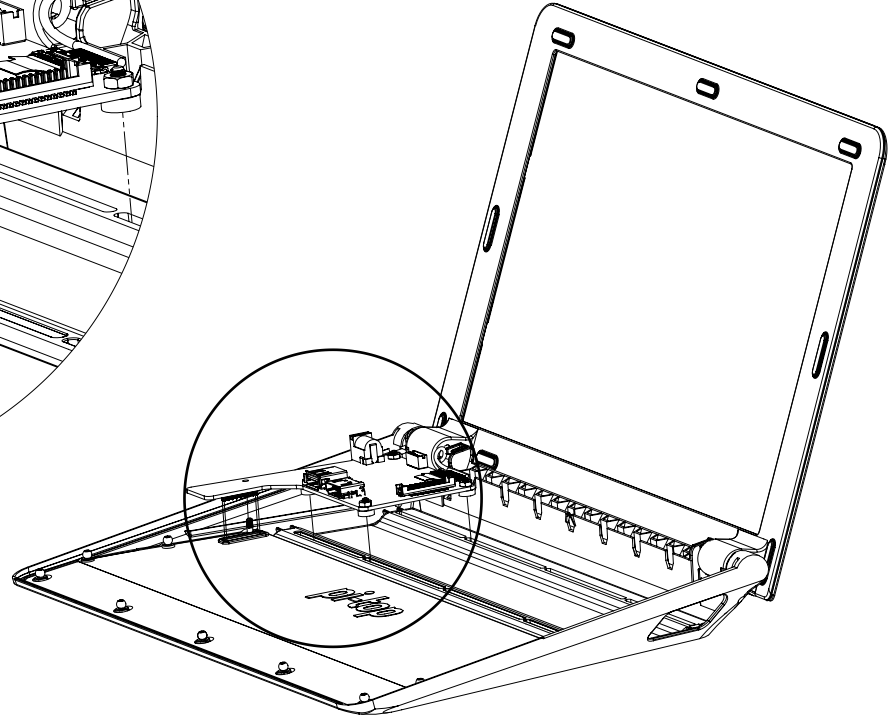

## Step 4.4: Secure Hub

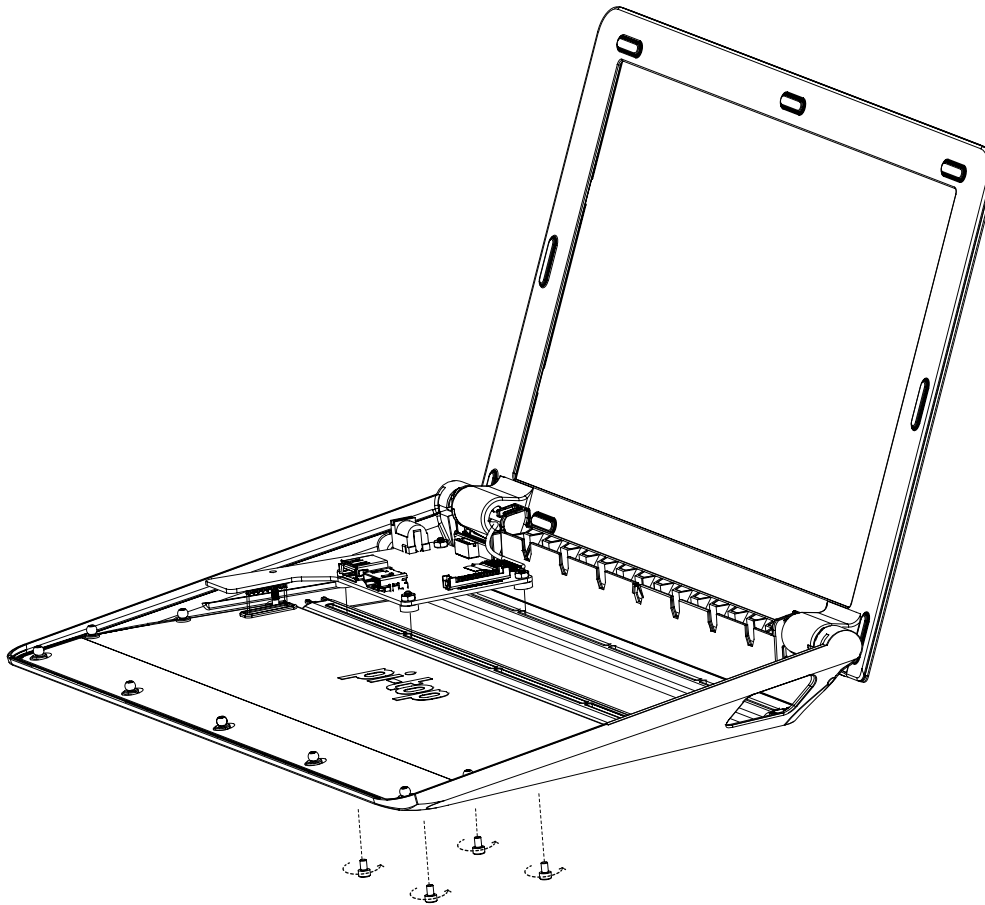

**Caution:** Do not over tighten as this could damage the screw head.

## Step 4.5: Secure Hub

Use M2.5 nut to secure battery connector. Fasten until it makes contact with the gold pad on the Hub, do not tighten with any tools.

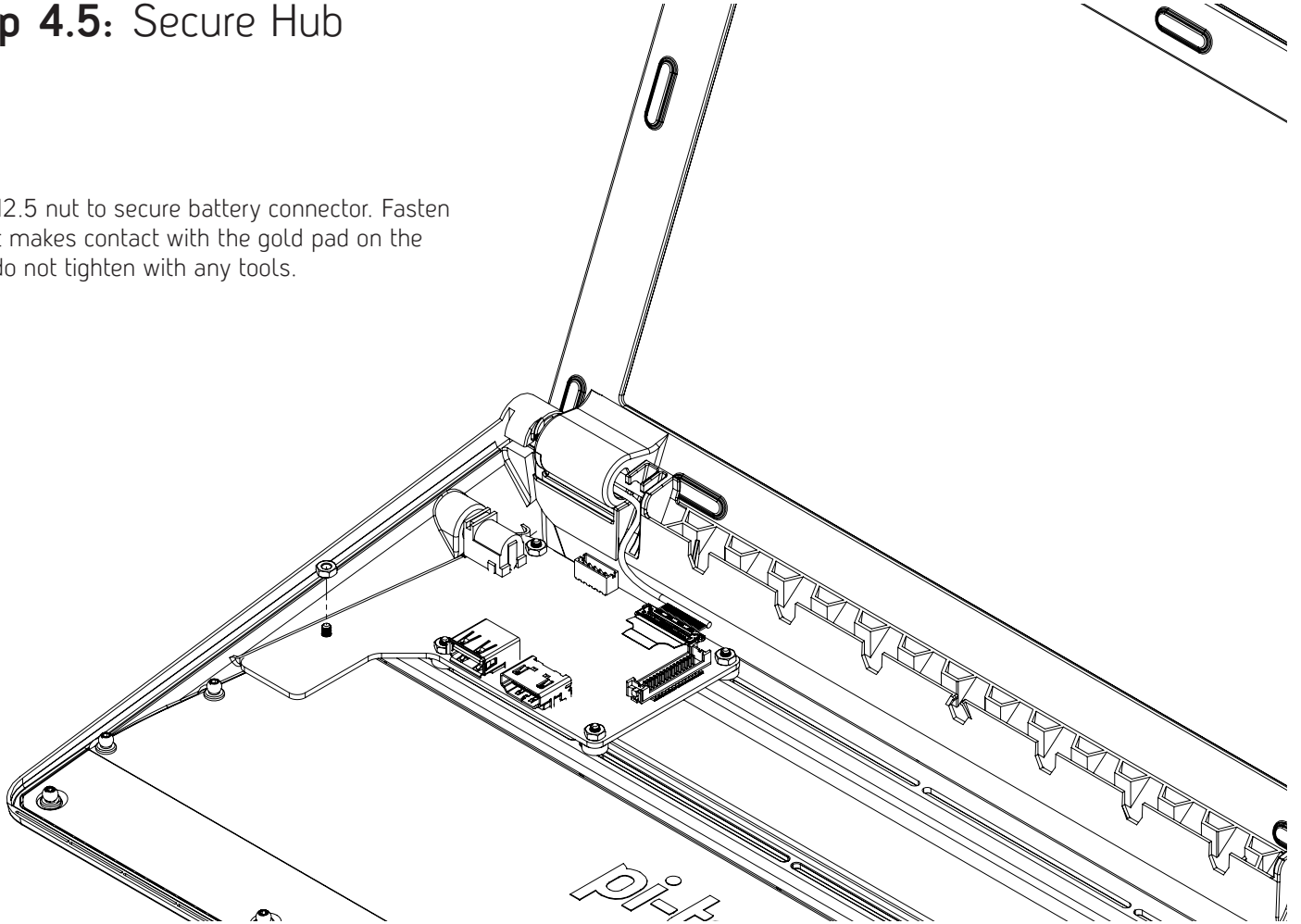

## Step 5: Install Micro Computer

### YOU WILL NEED

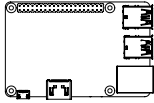

PCB SCREWS  
(Silver)

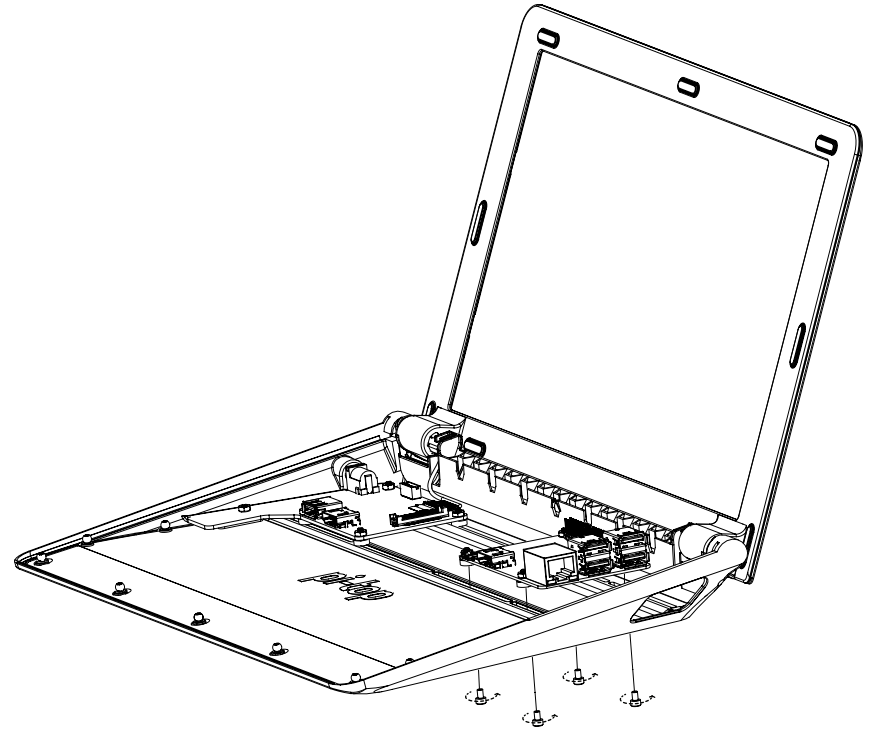

**Caution:** Over-tightening may damage PCB spacers – gently tighten until they just grip the Base.

# Step 6.1: Plug in Cables

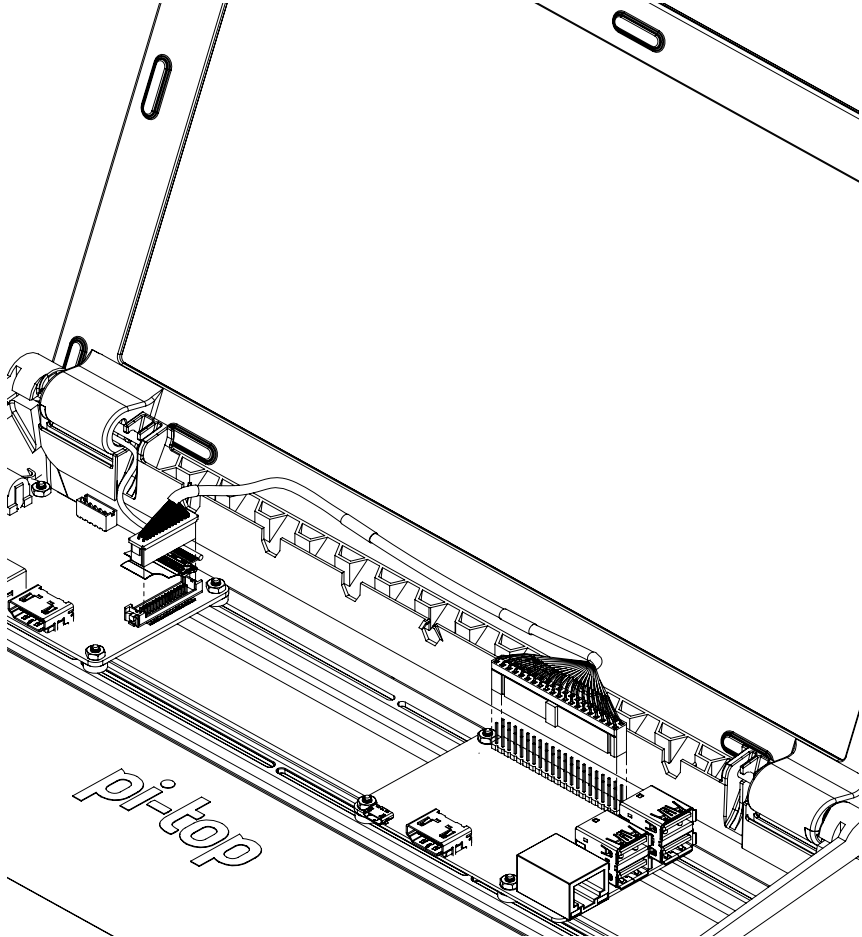
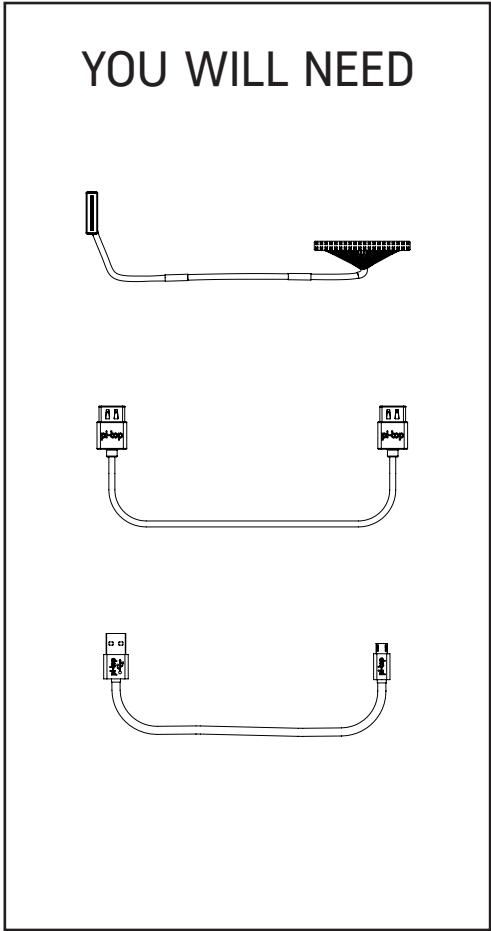

## Step 6.2: Plug in Cables

Be sure to insert the breakout cable the right way into the hub to avoid damaging the pins inside!

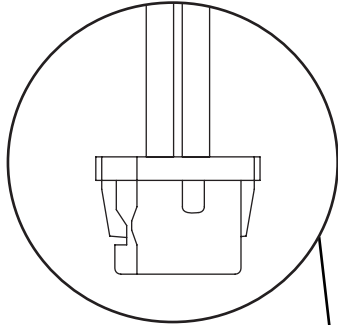

Correct connector orientation from looking front on at the Hub.

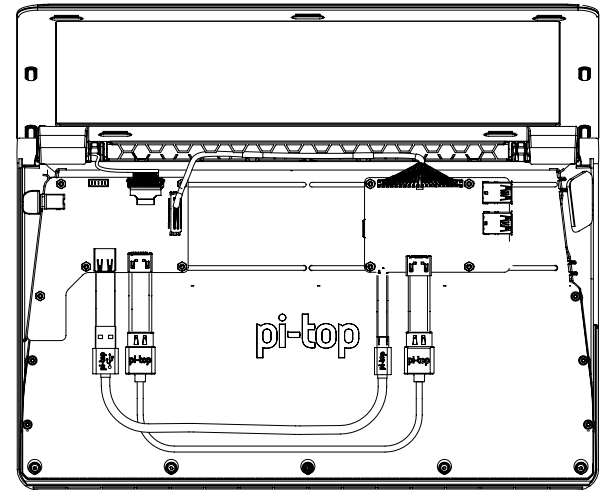
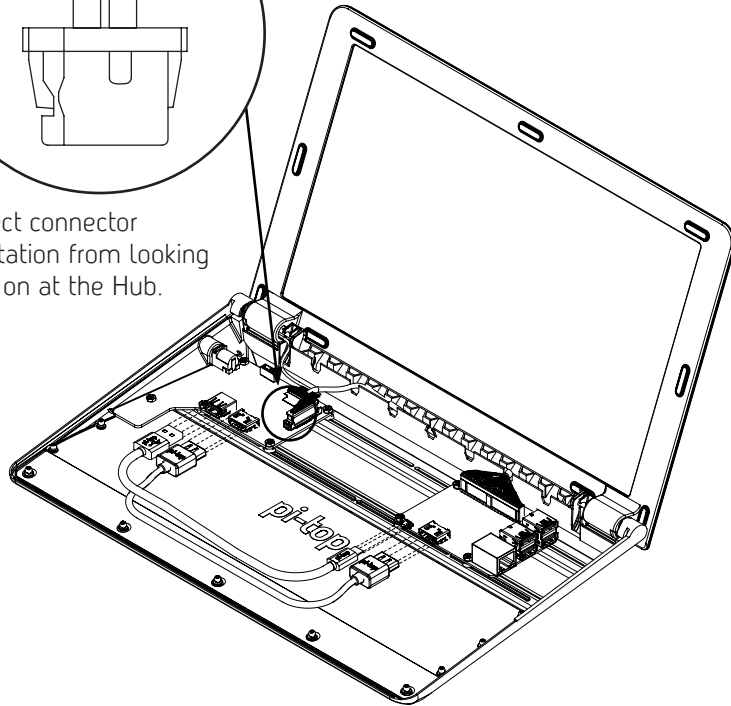



## Step 7.1: Prepare Base Top

YOU WILL NEED

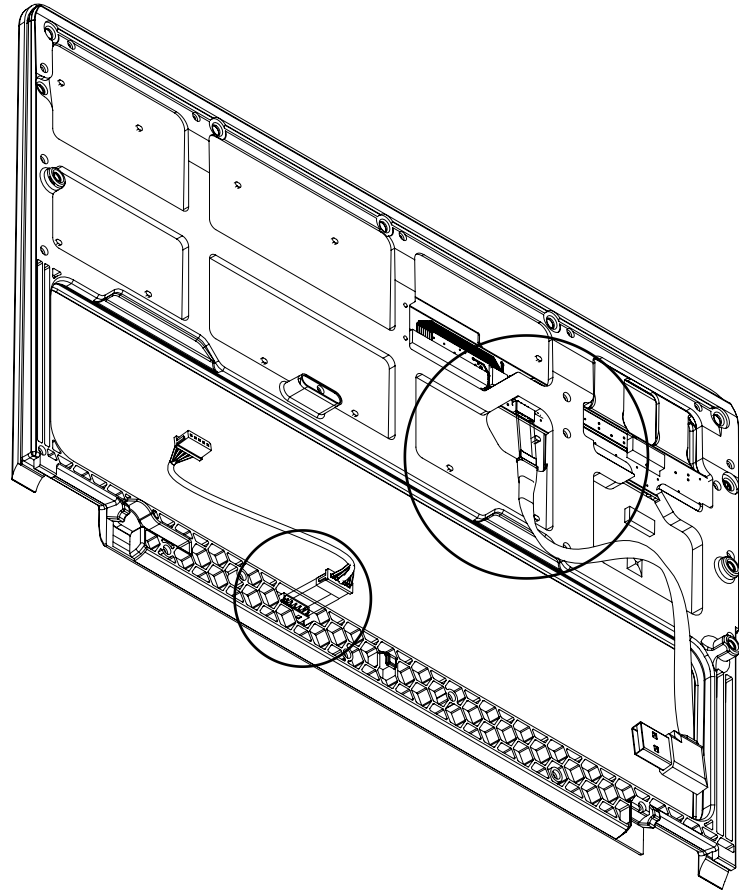
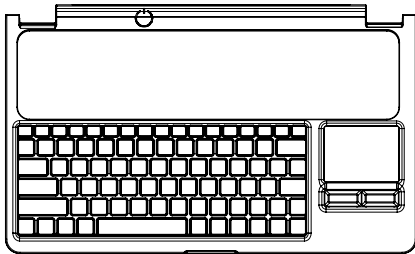
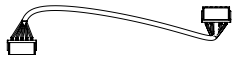
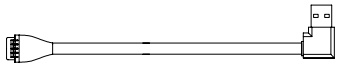

## Step 7.2: Prepare Base Top

Keyboard Connector can become loose with excessive cable movement, ensure it is fully inserted before attaching Base Top

