



Chipsmall Limited consists of a professional team with an average of over 10 year of expertise in the distribution of electronic components. Based in Hongkong, we have already established firm and mutual-benefit business relationships with customers from,Europe,America and south Asia,supplying obsolete and hard-to-find components to meet their specific needs.

With the principle of “Quality Parts,Customers Priority,Honest Operation,and Considerate Service”,our business mainly focus on the distribution of electronic components. Line cards we deal with include Microchip,ALPS,ROHM,Xilinx,Pulse,ON,Everlight and Freescale. Main products comprise IC,Modules,Potentiometer,IC Socket,Relay,Connector.Our parts cover such applications as commercial,industrial, and automotives areas.

We are looking forward to setting up business relationship with you and hope to provide you with the best service and solution. Let us make a better world for our industry!



Contact us

Tel: +86-755-8981 8866 Fax: +86-755-8427 6832

Email & Skype: info@chipsmall.com Web: www.chipsmall.com

Address: A1208, Overseas Decoration Building, #122 Zhenhua RD., Futian, Shenzhen, China



Dynamo Lantern

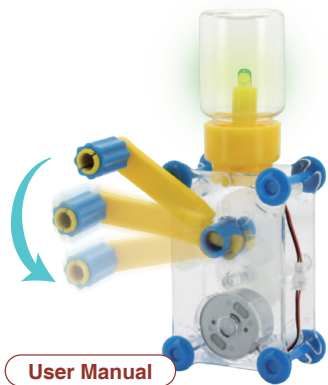

User Manual

WARNING:
WARNING: CHOKING HAZARD Small parts.
Not for children under 3 years old.

Build

By following our step-by-step guide, kids can easily build a dynamo lantern.

Play

Make the LED light change two different colors by rotating the hand crank in different directions. Water can also be placed in the LED lantern cover to make your very own water lantern!

Learn

Learn and understand the inner workings of a generator and how electricity works. Instruction manual also includes fun facts.

Warning:

1. CHOKING HAZARD - The product contains small pieces. Keep it away from children under 3.
2. DO NOT look at the LED light directly when it is lit up.
3. To avoid accidents, do not put your finger or hair into the product.
4. For your safety, do not put any parts of this product in contact with an AC power.

This product is recommended for children over 8 years of age, parents should read the manual carefully and guide their kids while they playing this product.

Part List

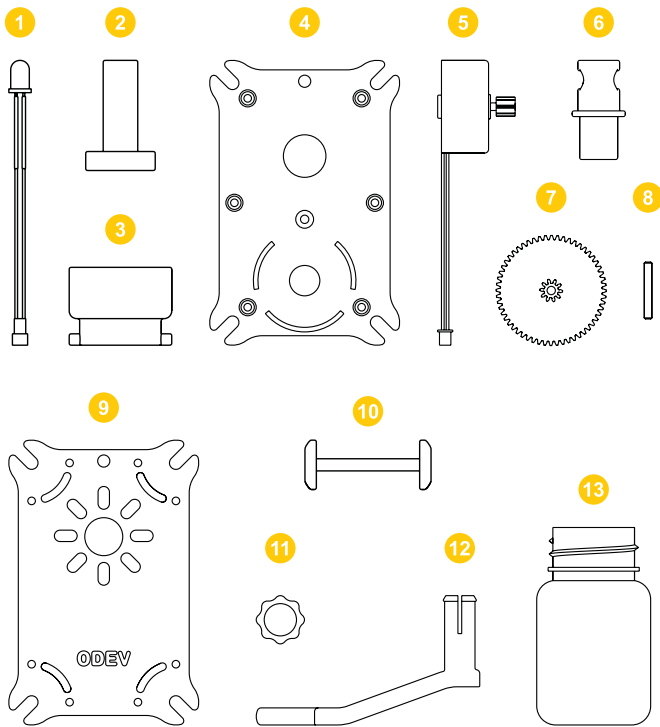

| | | | |
|--------------------|------|----------------------|------|
| 1 LED Light | 1pc | 8 Gear Shaft | 2pcs |
| 2 LED Holder | 1pc | 9 Right Panel | 1pc |
| 3 LED Lantern Base | 1pc | 10 Joint Clip | 4pcs |
| 4 Left Panel | 1pc | 11 Handle | 1pc |
| 5 Motor | 1pc | 12 Hand Crank | 1pc |
| 6 Joint Lever | 1pc | 13 LED Lantern Cover | 1pc |
| 7 Double Gears | 2pcs | | |

Assembly Instructions

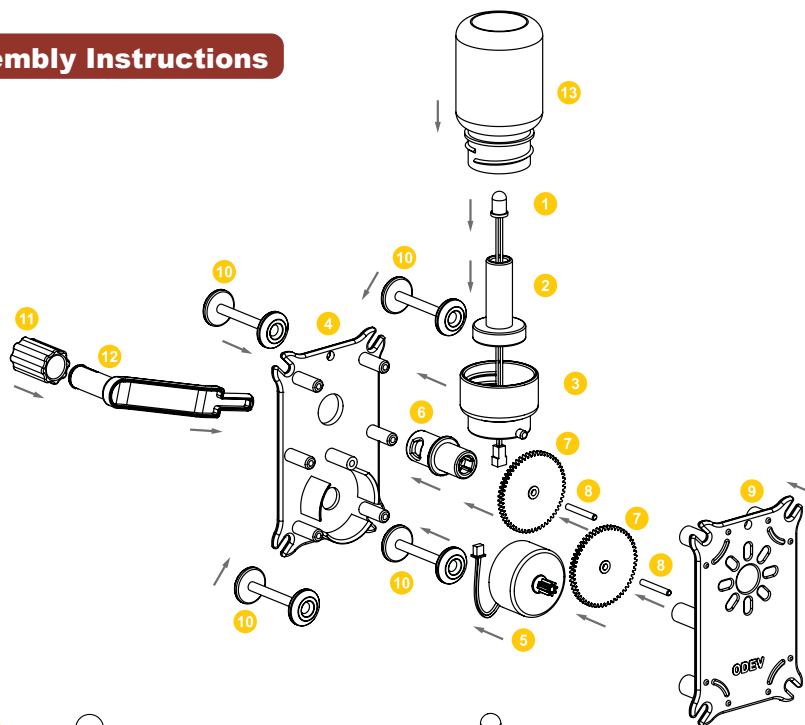

Are you ready?
Let's get it started!

Tips:

1. Please follow the directions on the manual carefully before assembling.
2. Know the parts before assembling.
3. Parental guidance is recommended.
4. Do not use the product if any part of this toy has been damaged or deformed.
5. Do not place motor in water as it may damage the product or cause injury.
6. Please keep the manual for later use.

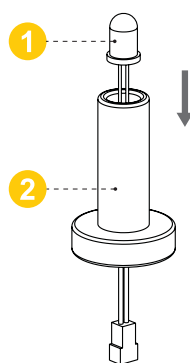

1. Put the LED light connector through the LED holder. Make sure the LED light is mounted correctly.

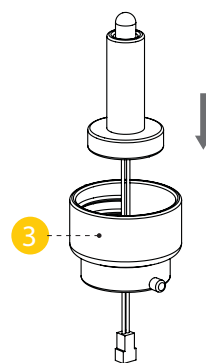

2. Put the connector through the LED lantern base, and make sure the LED light is mounted correctly on top of the lantern base.

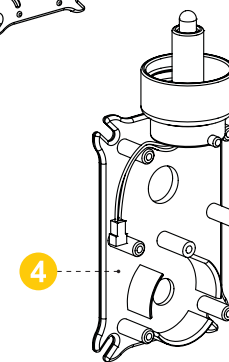

3. Now install the finished LED light component to the left panel. Winding the wire on the left panel as shown.

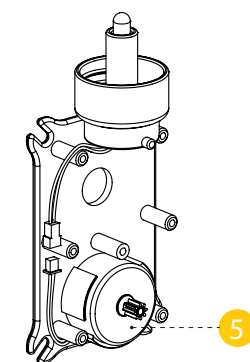

4. Mount the motor on the left panel. Winding the motor wire on the panel as shown.

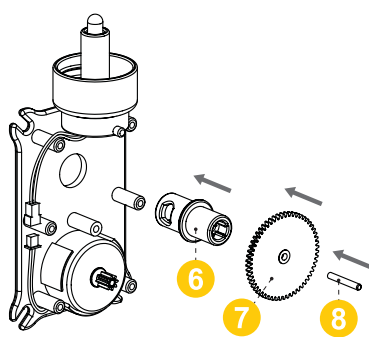

5. Attaching the joint lever to the panel, install the double gears on the joint lever, and finally insert the gear shaft into the double gear.

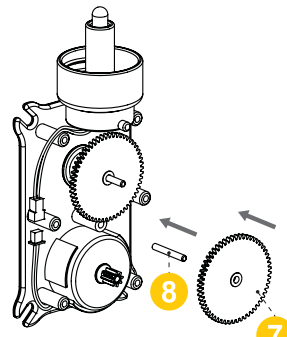

6. Install the gear shaft to the left panel and the double gear to the gear shaft. (Note: small gear facing inward, and large gear facing outward, and make sure the gears get a good grip.)

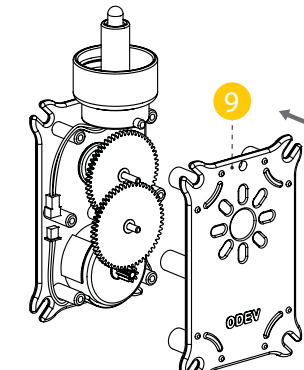

7. Cover up with the right panel. Make sure the shafts and holes are aligned correctly.

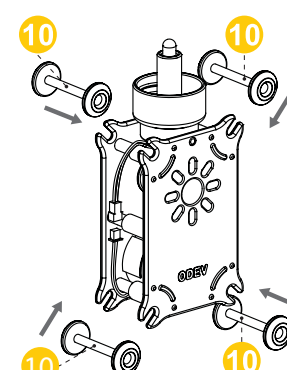

8. Install the joint clips to the corners, and place the wires between the joint clips and shafts of the two panels.

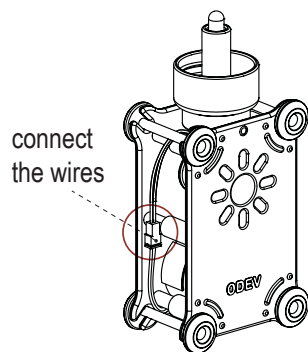

9. Connect the wires with the connectors. (Note: Parents can complete this step should the child experience difficulties seeing the connectors.)

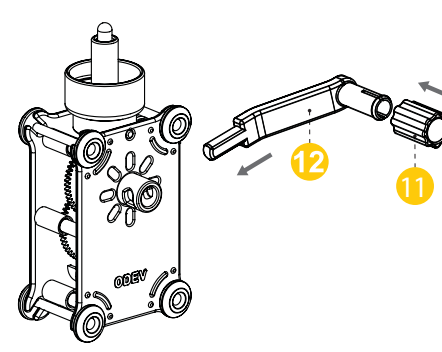

10. Attach the handle to the hand crank, and insert the finished component into the joint lever as shown.

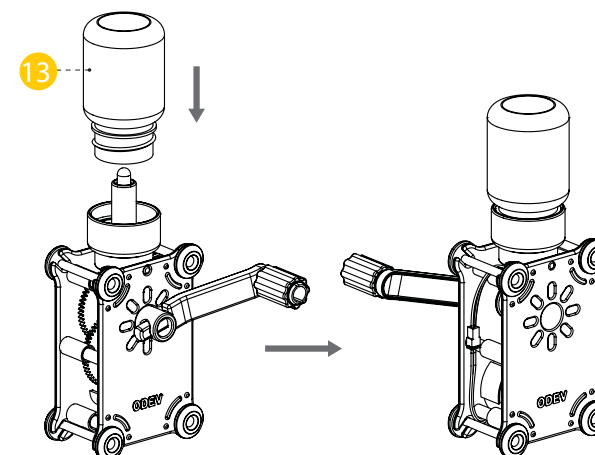

11. Put the plastic lantern cover on top of the LED light.

The Final Look

Troubleshooting

1. If the crank can not drive motor rotation, please check if gears are installed correctly. Ask parents for help if necessary.
2. If the LED lantern does not light up, please ensure all connections are in contact, especially the connectors of the two wires.

How To Play

1. Turn the crank clockwise or counterclockwise, the LED lantern will glow in blue and green light.
2. You can let the light irradiate to different angles by adjust the angle of the LED lantern base. (DO NOT look at the LED light directly when it is lit up.)
3. Quickly turn the crank back and forth, the LED light will alternately glow in blue and green light.
4. Fill the plastic lantern cover with water, screw the LED lantern components into it (as shown below), connect the plug, and turn the crank, the water will reflect the LED light.

Fun Tips: Add confetti or glitter to the water lantern for a light show snow lantern. Alternatively, add stickers to the outside to make some CRAZY shadows! For more tips/tricks, please visit our website at www.odevbot.com

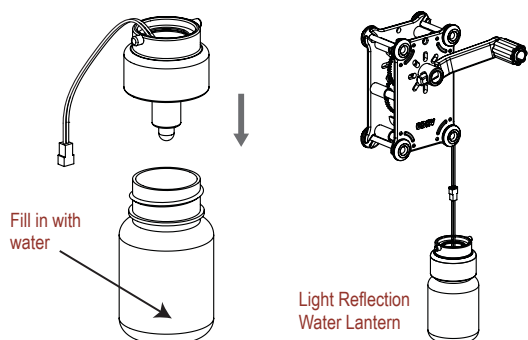

Attention: The voltage generated by this product is very low that will cause no harm to human. Do not do the same experiment to other lamp light as it may cause damage and serious injuries.

Let's learn some fun facts!

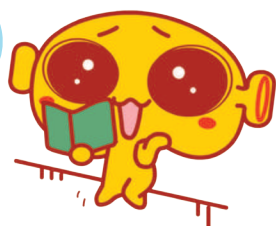

Q: Who is the first inventor of hand crank dynamo?



A: Michael Faraday was the first inventor of the hand crank dynamo. He was a brilliant scientist, who had an outstanding contribution to the electromagnetic field. A lot of physics theories found today have been derived from his research.

Michael Faraday (Sept. 22nd, 1791-Aug. 25th, 1867) was a famous British self-taught physicist and chemist. Born to a poor blacksmith family in Newington, Surrey County he had only attended elementary school as his formal education. On October 17th, 1831, Faraday first discovered the phenomenon of electromagnetic induction. This breakthrough in the field of electric power research changed human civilization, and his discovery was instrumental in Maxwell's equations (A set of partial differential equations that, together with the Lorentz force law, form the foundation of classical electromagnetism, classical optics, and electric circuits). Due to his contribution to electromagnetism, he was known as the "Father of Electricity".

After nearly 10 years of continuous experiments, Faraday concluded in 1831 the magnetic force of a current coil can not cause current in another coil. When the current coil power was just connected or interrupted, the current meter pointer in the other coil had a slight deflection. After repeated experiments, he confirmed

that when the magnetic force changed, the other coil would generate current. He also designed a variety of experiments, such as the relative movement of the two coils, the changes of magnetic force that can also produce current. In this way, Faraday finally opened the law of electromagnetic induction. The discovery for Faraday cleared the road to explore the nature of electromagnetics and opened a large number of new ways to generate currents.

Q: How is electricity generated from the Dynamo Lantern?

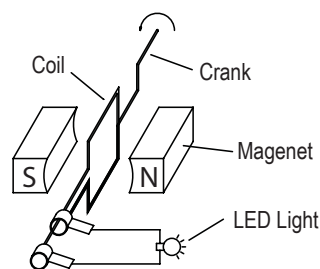

A: When a part of the conductors in closed circuits do the movement of cutting magnetic induction line in the magnetic field, the conductors will produce electric current, which is called electromagnetic induction phenomenon. In our Dynamo Lantern, the coils are coiled on the central shaft of the motor, with two magnets mounted on the inner wall of the motor casing. When the crank is turned, the central shaft rotates, producing a powerful current, then the LED lantern lights, which is the basis of the generator.

Q: What is the role of gears in the dynamo lantern?

A: To drive the motor to turn on the LED light requires a high speed. The hand rotation alone can not reach that speed, so we use the gears to help. Using the large gear drive pinion to rotate, we can increase the speed of the pinion. The gear speed is increased by the transmission ratio of the gears. The transmission ratio of the gears equal to the ratio of the drive gear speed to the driven gear speed (or inverse ratio of the number of teeth on the drive gear to the number of teeth on the driven gear).

The Basic Principle of Gear Rotation

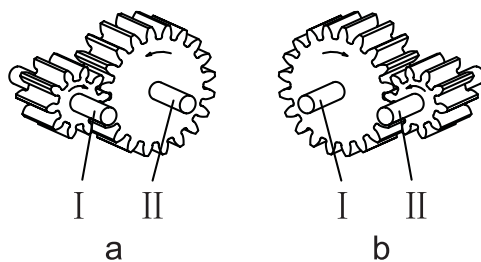

a. Deceleration b. Acceleration
I - Drive gear (pinion) II - Driven gear I - Drive gear II - Driven gear (pinion)

Figure a is the deceleration, that is the pinion drives the large gear to rotate. Figure b is the acceleration, that is the large gear drives the pinion to rotate.

Q: What is an LED? How does it light up?

A: LED is short for Light-Emitting Diode, with unilateral conductivity, as shown below. When the left side of the LED voltage is greater than the right side of the voltage exceeding a certain threshold, it will form a positive to negative forward conduction current, then the LED will be lit. On the contrary, when the LED is not damaged, it will not form a conduction current, and LED will not be lit.

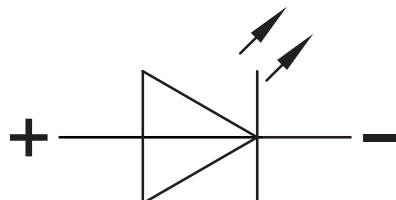

Do you know? Traffic lights are mostly used LED light as signal light source. It has many advantages like low power consumption, high brightness, compact size, light weight, long life span and so on.

Q: Why does the LED light produce different colors when moving the crank in different directions?

A: In fact, we use two-color light-emitting diodes, that is, two different colors of LED are in reverse parallel and packaged in "one" container. As shown on the right, when the current flows from the left to the right, the upper LED will be lit. On the contrary, the under LED will be lit. This is the secret of two different colors light in the forward and reverse rotation.

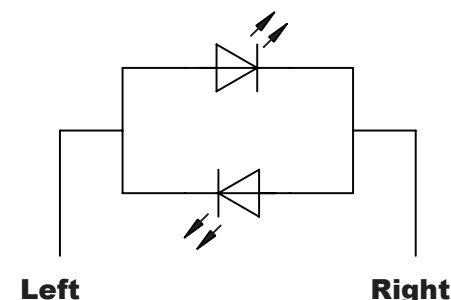

Wow!
You did a great job!



Designed and Distributed By:
Tenergy Corporation
436 Kato Terrace, Fremont, CA 94539, USA

Designed and Manufactured By:
Beijing Today Innovation Technology Co.,Ltd.
No.118, Floor 1, Building 1, No.7, North Ritan Road,
Chaoyang District, Beijing, PRC

Questions or comments?
Please call us at 1 510-687-0388 or
email us at service@Tenergy.com



www.odevbot.com