



Chipsmall Limited consists of a professional team with an average of over 10 year of expertise in the distribution of electronic components. Based in Hongkong, we have already established firm and mutual-benefit business relationships with customers from,Europe,America and south Asia,supplying obsolete and hard-to-find components to meet their specific needs.

With the principle of "Quality Parts,Customers Priority,Honest Operation,and Considerate Service",our business mainly focus on the distribution of electronic components. Line cards we deal with include Microchip,ALPS,ROHM,Xilinx,Pulse,ON,Everlight and Freescale. Main products comprise IC,Modules,Potentiometer,IC Socket,Relay,Connector.Our parts cover such applications as commercial,industrial, and automotives areas.

We are looking forward to setting up business relationship with you and hope to provide you with the best service and solution. Let us make a better world for our industry!



## Contact us

Tel: +86-755-8981 8866 Fax: +86-755-8427 6832

Email & Skype: info@chipsmall.com Web: www.chipsmall.com

Address: A1208, Overseas Decoration Building, #122 Zhenhua RD., Futian, Shenzhen, China



# KIT34670EGEVBE Evaluation Board

## Table of Contents

Kit Contents / Packing List .....	2
Notification / Disclaimer .....	3
Using the EVB .....	4
Schematic .....	11
Board Layout .....	12
Bill of Material .....	19
References .....	21
Revision History .....	22

# 1 Kit Contents / Packing List

- Evaluation Board - KIT34670EGEVBE
- Hardware Document CD, CD34670
- 2, CAT-5E Cables

## 2 Important Notice

Freescale provides the enclosed product(s) under the following conditions:

This evaluation kit is intended for use of ENGINEERING DEVELOPMENT OR EVALUATION PURPOSES ONLY. It is provided as a sample IC pre-soldered to a printed circuit board to make it easier to access inputs, outputs, and supply terminals. This EVB may be used with any development system or other source of I/O signals by simply connecting it to the host MCU or computer board via off-the-shelf cables. This EVB is not a Reference Design and is not intended to represent a final design recommendation for any particular application. Final device in an application will be heavily dependent on proper printed circuit board layout and heat sinking design as well as attention to supply filtering, transient suppression, and I/O signal quality.

The goods provided may not be complete in terms of required design, marketing, and or manufacturing related protective considerations, including product safety measures typically found in the end product incorporating the goods. Due to the open construction of the product, it is the user's responsibility to take any and all appropriate precautions with regard to electrostatic discharge. In order to minimize risks associated with the customers applications, adequate design and operating safeguards must be provided by the customer to minimize inherent or procedural hazards. For any safety concerns, contact Freescale sales and technical support services.

Should this evaluation kit not meet the specifications indicated in the kit, it may be returned within 30 days from the date of delivery and will be replaced by a new kit.

Freescale reserves the right to make changes without further notice to any products herein. Freescale makes no warranty, representation or guarantee regarding the suitability of its products for any particular purpose, nor does Freescale assume any liability arising out of the application or use of any product or circuit, and specifically disclaims any and all liability, including without limitation consequential or incidental damages. "Typical" parameters can and do vary in different applications and actual performance may vary over time. All operating parameters, including "Typical", must be validated for each customer application by customer's technical experts.

Freescale does not convey any license under its patent rights nor the rights of others. Freescale products are not designed, intended, or authorized for use as components in systems intended for surgical implant into the body, or other applications intended to support or sustain life, or for any other application in which the failure of the Freescale product could create a situation where personal injury or death may occur.

Should Buyer purchase or use Freescale products for any such unintended or unauthorized application, Buyer shall indemnify and hold Freescale and its officers, employees, subsidiaries, affiliates, and distributors harmless against all claims, costs, damages, and expenses, and reasonable attorney fees arising out of, directly or indirectly, any claim of personal injury or death associated with such unintended or unauthorized use, even if such claim alleges that Freescale was negligent regarding the design or manufacture of the part. Freescale™ and the Freescale logo are trademarks of Freescale Semiconductor, Inc. All other product or service names are the property of their respective owners. © Freescale Semiconductor, Inc. 2008

## 3 Using the EVB

**Warning: Always wear Safety Glasses when working around electronic modules and when soldering.**

1. The KIT34670EGEVBE is ready for use. However, to change the class of the PD, set jumper P4 to the desired position. Connect your Ethernet cable from the PoE switch or hub to the left RJ45 connector on the board. The Ethernet cable going to your application must be plugged into the right RJ45 connector.
2. Solder two wires onto the VO and SGND pads (right, upper corner of board) and connect or solder the wires to your applications supply input lines. The board delivers 5V, so make sure your application accepts 5V. Watch the correct polarity when connecting the wires to your application.
3. To change the oscillator frequency from the default value to your frequency of choice, remove jumper P3 and use R12 to adjust the frequency. The EVB must be in normal operating mode (GATE switching) to adjust the frequency. Connect an oscilloscope between pin 19 (GATE) and pin 11, 12, or 13 (VOUT) of the MC34670 and control the frequency during your adjustment. Also control VO on the board with a voltmeter. This adjustment should be made without an application connected.
4. To change the inrush current limit, exchange resistor R8 with an appropriate resistor value. Please read the MC34670 datasheet or application note A/N3279 (CD-ROM) for adjusting the inrush current limit and proper resistor value. The board is pre-setup with the default (highest) inrush current limit compliant to IEEE802.3af.
5. To change the UVLO setting, two resistors must be altered, R2 and R7. To find the correct values for the resistors, please refer to the datasheet or application note. The board is pre-setup with the default values for the UVLO setting compliant to IEEE802.3af.

## 4 EVB Setup Configuration Diagram

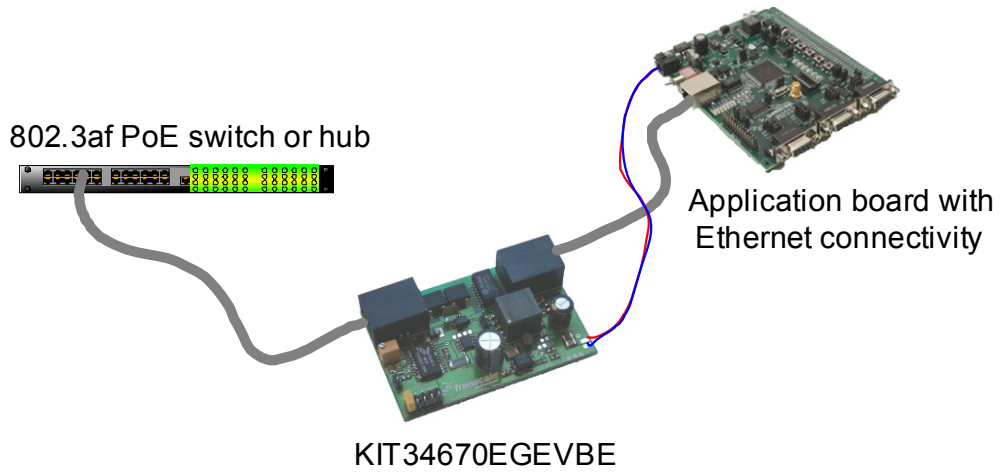

Figure 1. EVB Setup Configuration Diagram

# 5 EVB Schematic

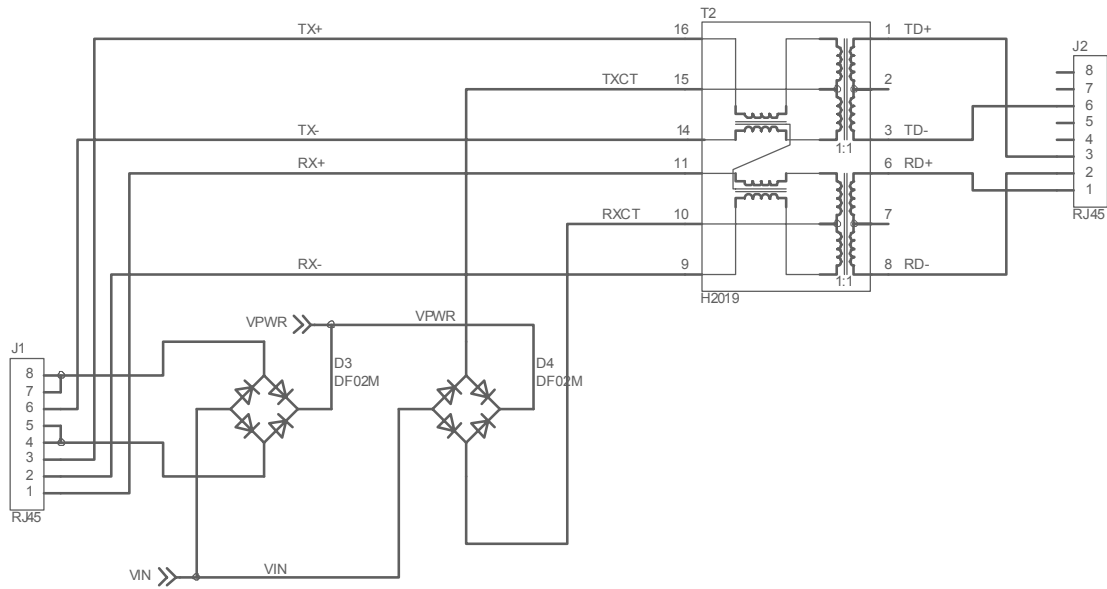

Figure 2. EVB Schematic 1

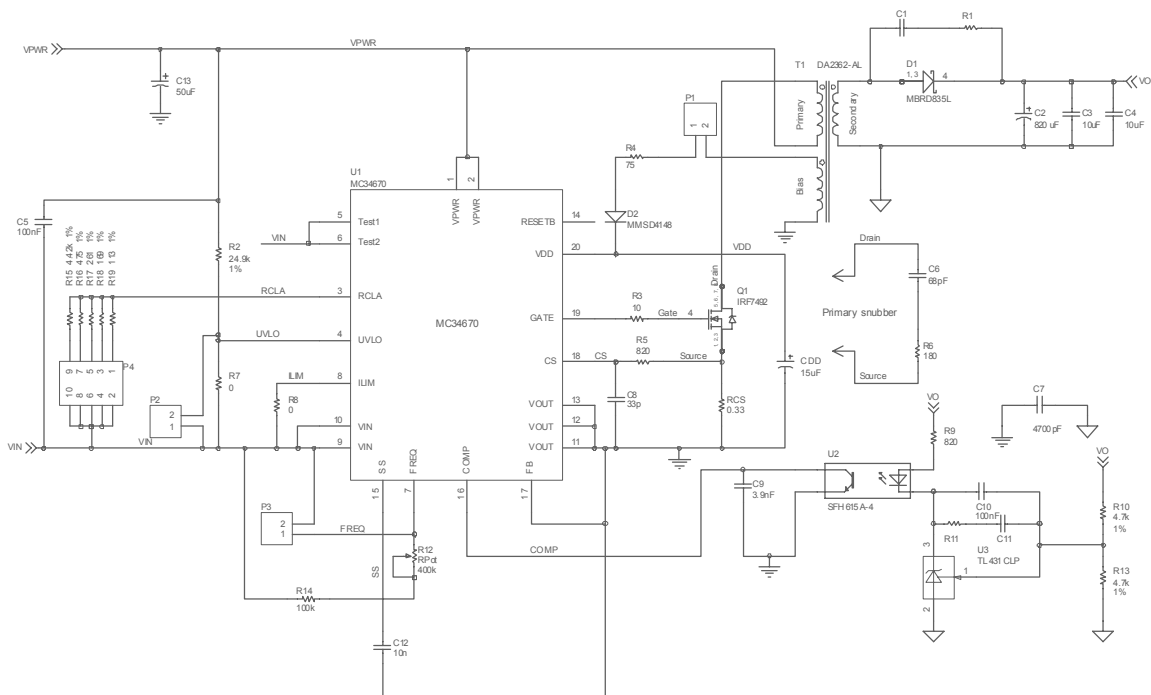

Figure 3. EVB Schematic 2

## 6 Board Layout

### 6.1 Assembly Drawing

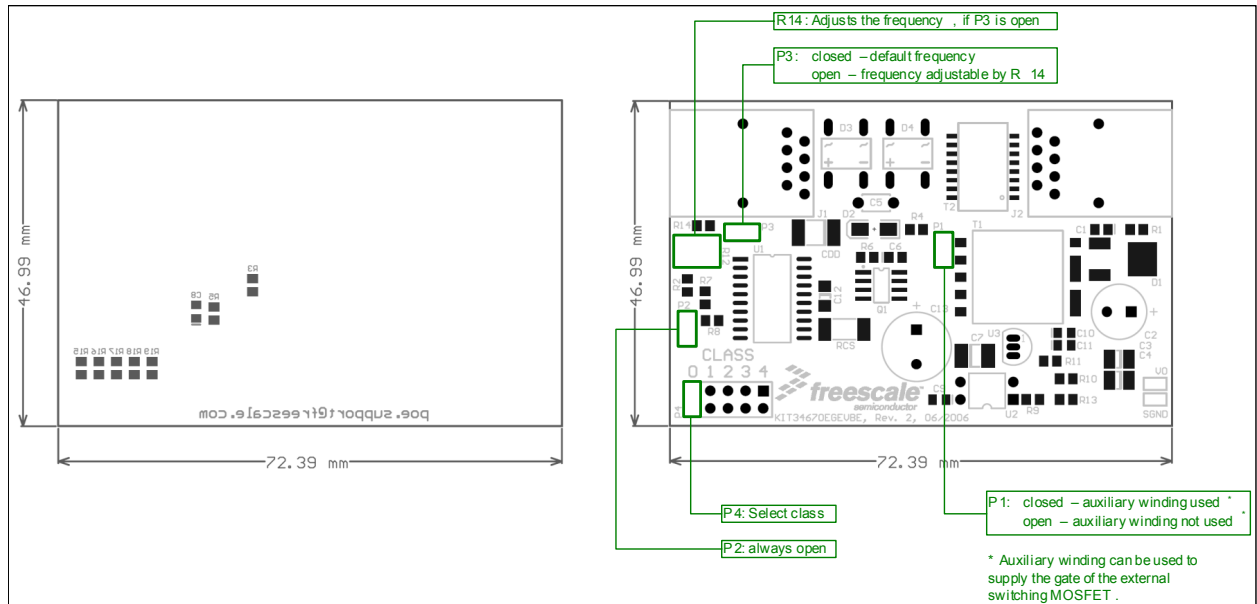

Figure 4. Assembly Drawing



## 6.2 Top Copper

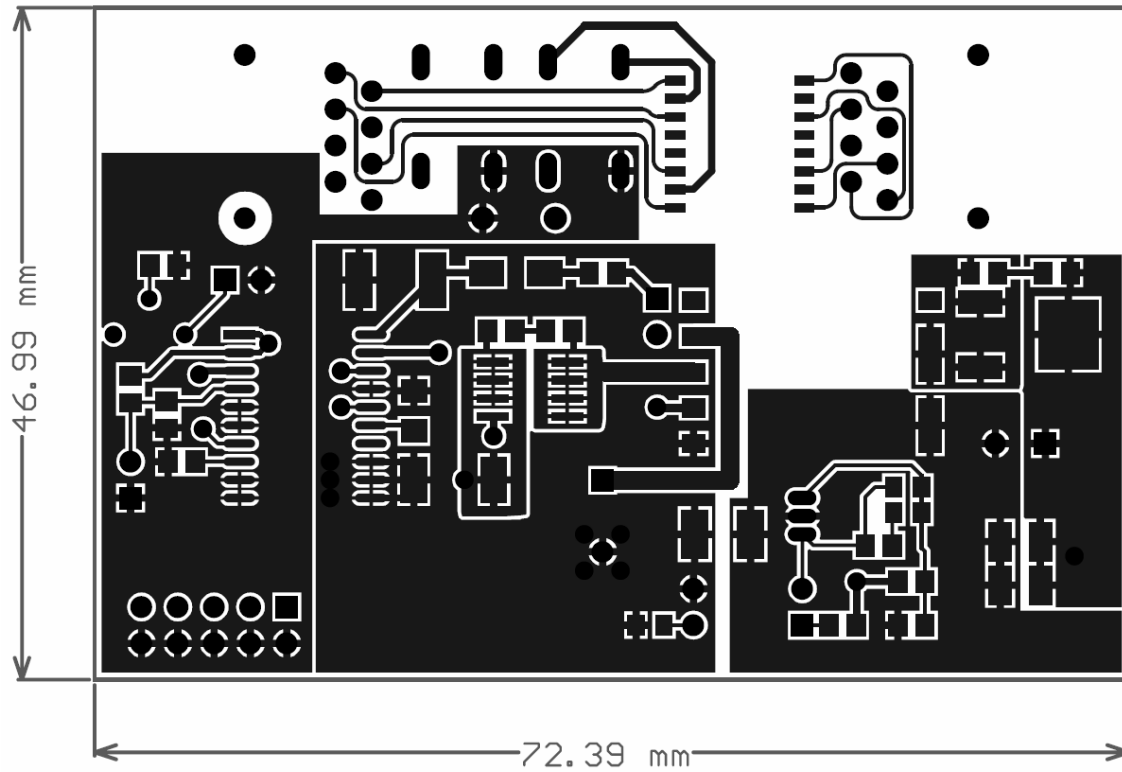

Figure 5. Top Copper

## 6.3 Bottom Copper

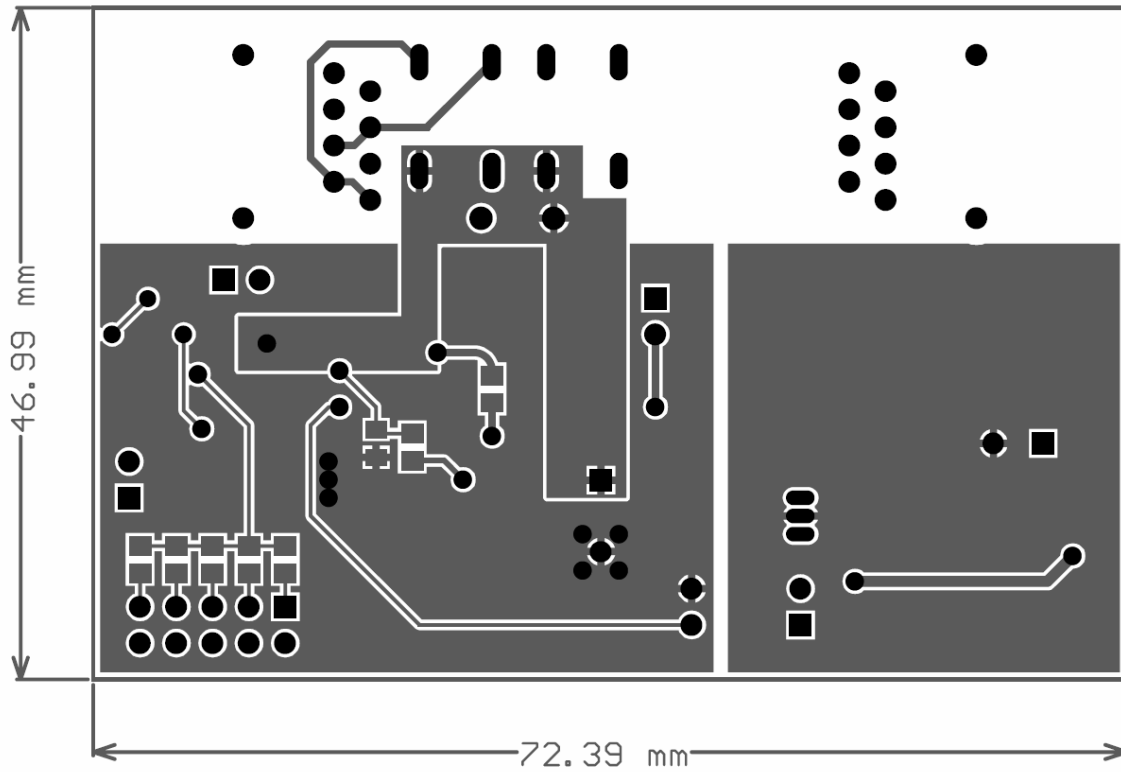

Figure 6. Bottom Copper

## 7 Bill of Material

Qty	PN	Ref.	Package	Description	Manufacturer
<b>Freescale Components</b>					
1	MCZ34670EG	U1	SOIC20WB	Freescale MC34670	Freescale
<b>Capacitors</b>					
1		C1	0805	n/a	any
1		C2	CAPPR3.5-8x10.5	Capacitor, 820uF, 6V	any
1		C3	1210	Capacitor, ceramic, 10uF, 6V, X7R	any
1		C4	1210	Capacitor, ceramic, 10uF, 6V, X7R	any
1		C5	CAPR5.08-4x2.5	Capacitor, ceramic, 100nF, 100V	any
1		C6	0805	Capacitor, ceramic, 68pF	any
1		C7	CC4532-1812	Capacitor, ceramic, 4700pF, 1000V	any
1		C8	0805	Capacitor, ceramic, 33pF	any
1		C9	0805	Capacitor, ceramic, 3.9nF	any
1		C10	0805	Capacitor, ceramic, 100nF	any
1		C11	0805	n/a	any
1		C12	CC3216-1206	Capacitor, ceramic, 10nF	any
1		C13	CAPPR5-10x16	Capacitor, electrolytic, 50uF, 100V	any
1		CDD	CC5634-2213	Capacitor, tantalum, 15uF, 16V	any
<b>Diodes</b>					
1	MBRD835LT4G	D1	DKPAK CASE 369A-13	Schottky Diode	ON Semiconductor
1	MMSD4148	D2	SMA	Schottky Diode	Fairchild
1	DF02M	D3	DIP4	Full Wave Diode Bridge	Fairchild
1	DF02M	D4	DIP4	Full Wave Diode Bridge	Fairchild
<b>Resistors</b>					
1		R1	0805	n/a	any
1		R2	0805	Resistor, 24.9kOhm, 1%	any
1		R3	0805	Resistor, 100Ohm, 5%	any
1		R4	0805	Resistor, 250Ohm, 5%	any
1		R5	0805	Resistor, 820Ohm, 5%	any
1		R6	0805	Resistor, 180Ohm, 5%	any
1		R7	0805	Resistor, 0Ohm	any
1		R8	0805	Resistor, 0Ohm	any
1		R9	0805	Resistor, 820Ohm, 5%	any
1		R10	0805	Resistor, 4.7k, 1%	any
1		R11	0805	n/a	any
1		R12	RPot	Potentiometer, 400k	any
1		R13	0805	Resistor, 4.7k, 1%	any
1		R14	0805	Resistor, 100k, 5%	any
1		R15	0805	Resistor, 4.42k, 1%	any
1		R16	0805	Resistor, 4750Ohm, 1%	any
1		R17	0805	Resistor, 2610Ohm, 1%	any
1		R18	0805	Resistor, 1690Ohm, 1%	any
1		R19	0805	Resistor, 1130Ohm, 1%	any
1		RCS	2512	Resistor, 0.33Ohm	any
<b>Misc</b>					
1	SS-7188-NF	J1	SS-7188-NF	Stewart RJ45 Cat5 connector	Stewart
1	SS-7188-NF	J2	SS-7188-NF	Stewart RJ45 Cat5 connector	Stewart
1		P1	HDR1X2	Header, 2-Pin	any
1		P2	HDR1X2	Header, 2-Pin	any
1		P3	HDR1X2	Header, 2-Pin	any
1		P4	HDR2X5	Header, 5-Pin, Dual row	any
1	IRF7492	Q1	SO-8	HEXFET Power MOSFET	IRF
1	DA 2362-AL	T1	POE13P	PoE transformer 5V 13W	Coilcraft
1	H2019NL	T2	H2019	Data transformer	Pulse
1	SFH615A-4	U2	DIP-4	Optocoupler CTR=400%	Isocom
1	TL431ACLP	U3	29-04	Programmable Precision Reference	Fairchild
2	380-1064		100	Cat-5e cable	Stewart

## 8 References

Following are URLs where you can obtain information on other Freescale products and application solutions:

Description	URL
Data Sheet - MC34670	<a href="http://www.freescale.com/files/analog/doc/data_sheet/MC34670.pdf">www.freescale.com/files/analog/doc/data_sheet/MC34670.pdf</a>
Freescale's Web Site	<a href="http://www.freescale.com">www.freescale.com</a>
Freescale's Analog Web Site	<a href="http://www.freescale.com/analog">www.freescale.com/analog</a>
Freescale's Power Management Web Site	<a href="http://www.freescale.com/powermanagement">www.freescale.com/powermanagement</a>

## 9 Revision History

REVISION	DATE	DESCRIPTION OF CHANGES
1.0	7/2008	<ul style="list-style-type: none"><li>Initial Release</li></ul>

## **How to Reach Us:**

### **Home Page:**

[www.freescale.com](http://www.freescale.com)

### **Web Support:**

<http://www.freescale.com/support>

### **USA/Europe or Locations Not Listed:**

Freescale Semiconductor, Inc.  
Technical Information Center, EL516  
2100 East Elliot Road  
Tempe, Arizona 85284  
+1-800-521-6274 or +1-480-768-2130  
[www.freescale.com/support](http://www.freescale.com/support)

### **Europe, Middle East, and Africa:**

Freescale Halbleiter Deutschland GmbH  
Technical Information Center  
Schatzbogen 7  
81829 Muenchen, Germany  
+44 1296 380 456 (English)  
+46 8 52200080 (English)  
+49 89 92103 559 (German)  
+33 1 69 35 48 48 (French)  
[www.freescale.com/support](http://www.freescale.com/support)

### **Japan:**

Freescale Semiconductor Japan Ltd.  
Headquarters  
ARCO Tower 15F  
1-8-1, Shimo-Meguro, Meguro-ku,  
Tokyo 153-0064  
Japan  
0120 191014 or +81 3 5437 9125  
[support.japan@freescale.com](mailto:support.japan@freescale.com)

### **Asia/Pacific:**

Freescale Semiconductor Hong Kong Ltd.  
Technical Information Center  
2 Dai King Street  
Tai Po Industrial Estate  
Tai Po, N.T., Hong Kong  
+800 2666 8080  
[support.asia@freescale.com](mailto:support.asia@freescale.com)

### **For Literature Requests Only:**

Freescale Semiconductor Literature Distribution Center  
P.O. Box 5405  
Denver, Colorado 80217  
1-800-441-2447 or 303-675-2140  
Fax: 303-675-2150  
[LDCForFreescaleSemiconductor@hibbertgroup.com](mailto:LDCForFreescaleSemiconductor@hibbertgroup.com)

RoHS-compliant and/or Pb-free versions of Freescale products have the functionality and electrical characteristics of their non-RoHS-compliant and/or non-Pb-free counterparts. For further information, see <http://www.freescale.com> or contact your Freescale sales representative.

For information on Freescale's Environmental Products program, go to <http://www.freescale.com/epp>.

Information in this document is provided solely to enable system and software implementers to use Freescale Semiconductor products. There are no express or implied copyright licenses granted hereunder to design or fabricate any integrated circuits or integrated circuits based on the information in this document.

Freescale Semiconductor reserves the right to make changes without further notice to any products herein. Freescale Semiconductor makes no warranty, representation or guarantee regarding the suitability of its products for any particular purpose, nor does Freescale Semiconductor assume any liability arising out of the application or use of any product or circuit, and specifically disclaims any and all liability, including without limitation consequential or incidental damages. "Typical" parameters that may be provided in Freescale Semiconductor data sheets and/or specifications can and do vary in different applications and actual performance may vary over time. All operating parameters, including "Typicals", must be validated for each customer application by customer's technical experts. Freescale Semiconductor does not convey any license under its patent rights nor the rights of others. Freescale Semiconductor products are not designed, intended, or authorized for use as components in systems intended for surgical implant into the body, or other applications intended to support or sustain life, or for any other application in which the failure of the Freescale Semiconductor product could create a situation where personal injury or death may occur. Should Buyer purchase or use Freescale Semiconductor products for any such unintended or unauthorized application, Buyer shall indemnify and hold Freescale Semiconductor and its officers, employees, subsidiaries, affiliates, and distributors harmless against all claims, costs, damages, and expenses, and reasonable attorney fees arising out of, directly or indirectly, any claim of personal injury or death associated with such unintended or unauthorized use, even if such claim alleges that Freescale Semiconductor was negligent regarding the design or manufacture of the part.

Freescale™ and the Freescale logo are trademarks of Freescale Semiconductor, Inc. All other product or service names are the property of their respective owners.

© Freescale Semiconductor, Inc., 2009. All rights reserved.