



Chipsmall Limited consists of a professional team with an average of over 10 year of expertise in the distribution of electronic components. Based in Hongkong, we have already established firm and mutual-benefit business relationships with customers from,Europe,America and south Asia,supplying obsolete and hard-to-find components to meet their specific needs.

With the principle of “Quality Parts,Customers Priority,Honest Operation,and Considerate Service”,our business mainly focus on the distribution of electronic components. Line cards we deal with include Microchip,ALPS,ROHM,Xilinx,Pulse,ON,Everlight and Freescale. Main products comprise IC,Modules,Potentiometer,IC Socket,Relay,Connector.Our parts cover such applications as commercial,industrial, and automotives areas.

We are looking forward to setting up business relationship with you and hope to provide you with the best service and solution. Let us make a better world for our industry!



Contact us

Tel: +86-755-8981 8866 Fax: +86-755-8427 6832

Email & Skype: info@chipsmall.com Web: www.chipsmall.com

Address: A1208, Overseas Decoration Building, #122 Zhenhua RD., Futian, Shenzhen, China



KITPF0100SKTEVBE Programming Socket

Configures PF Family Devices

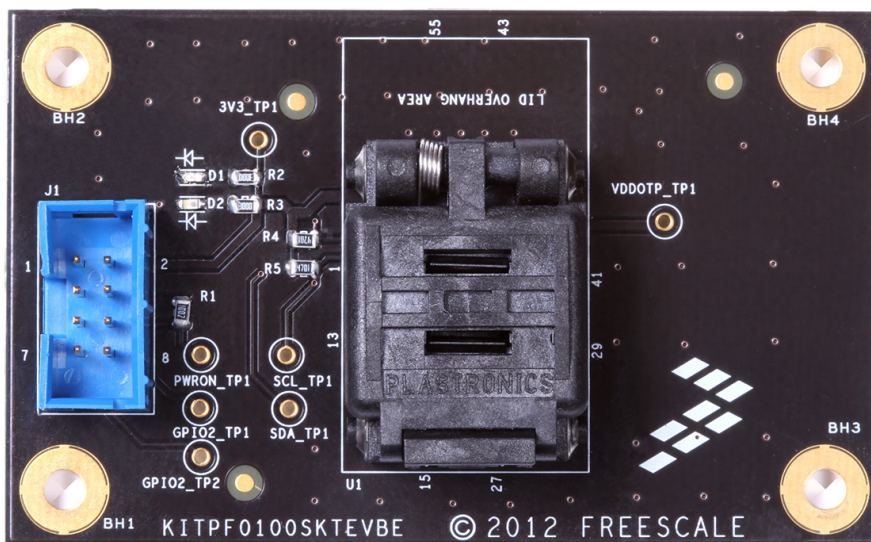

Figure 1. PF Programming Socket (KITPF0100SKTEVBE)

Table of Contents

1 Kit Contents/Packing List	2
2 Jump Start	2
3 Important Notice	3
4 Introduction	4
5 PF Programmer	4
6 Additional Required Equipment	4
7 Setting Up and Using the Hardware	5
8 Schematic	7
9 Board Layout	8
10 References	10
11 Revision History	11

1 Kit Contents/Packing List

- KITPF0100SKTEVBE socket board
- Warranty card and technical support brochure

2 Jump Start

- Go to www.freescale.com/analogtools
- Locate your kit
- Review your Tool Summary Page
- Look for



Jump Start Your Design

- Download documents, software and other information

3 Important Notice

Freescale provides the enclosed product(s) under the following conditions:

This evaluation kit is intended for use of ENGINEERING DEVELOPMENT OR EVALUATION PURPOSES ONLY. It is provided as a sample IC pre-soldered to a printed circuit board to make it easier to access inputs, outputs, and supply terminals. This EVB may be used with any development system or other source of I/O signals by simply connecting it to the host MCU or computer board via off-the-shelf cables. This EVB is not a Reference Design and is not intended to represent a final design recommendation for any particular application. Final device in an application will be heavily dependent on proper printed circuit board layout and heat sinking design as well as attention to supply filtering, transient suppression, and I/O signal quality.

The goods provided may not be complete in terms of required design, marketing, and or manufacturing related protective considerations, including product safety measures typically found in the end product incorporating the goods. Due to the open construction of the product, it is the user's responsibility to take any and all appropriate precautions with regard to electrostatic discharge. In order to minimize risks associated with the customers applications, adequate design and operating safeguards must be provided by the customer to minimize inherent or procedural hazards. For any safety concerns, contact Freescale sales and technical support services.

Should this evaluation kit not meet the specifications indicated in the kit, it may be returned within 30 days from the date of delivery and will be replaced by a new kit.

Freescale reserves the right to make changes without further notice to any products herein. Freescale makes no warranty, representation or guarantee regarding the suitability of its products for any particular purpose, nor does Freescale assume any liability arising out of the application or use of any product or circuit, and specifically disclaims any and all liability, including without limitation consequential or incidental damages. "Typical" parameters can and do vary in different applications and actual performance may vary over time. All operating parameters, including "Typical", must be validated for each customer application by customer's technical experts.

Freescale does not convey any license under its patent rights nor the rights of others. Freescale products are not designed, intended, or authorized for use as components in systems intended for surgical implant into the body, or other applications intended to support or sustain life, or for any other application in which the failure of the Freescale product could create a situation where personal injury or death may occur.

Should Buyer purchase or use Freescale products for any such unintended or unauthorized application, Buyer shall indemnify and hold Freescale and its officers, employees, subsidiaries, affiliates, and distributors harmless against all claims, costs, damages, and expenses, and reasonable attorney fees arising out of, directly or indirectly, any claim of personal injury or death associated with such unintended or unauthorized use, even if such claim alleges that Freescale was negligent regarding the design or manufacture of the part. Freescale™ and the Freescale logo are trademarks of Freescale Semiconductor, Inc. All other product or service names are the property of their respective owners.

© Freescale Semiconductor, Inc. 2013

4 Introduction

The KITPF0100SKTEVBE is an interface tool featuring a 56-pin QFN socket that is designed for programming the PF0x00 one-time programmable (OTP) registers in standalone PF0x00 parts by using the KITPFPGMEVME programmer.

5 PF Programmer

The PF Programmer (KITPFPGMEVME) is a development tool designed to provide easy configuration of the PF Series devices and to facilitate prototyping and programming the device's (OTP) one-time programmable fuses. The programmer kit comes with a PF series programmer, a flat ribbon cable (eight-conductor) and a mini-USB cable, as shown in [Figure 2](#).



Figure 2. KITPFPGMEVME PF Series Programmer

6 Additional Required Equipment

- USB-enabled PC with Windows XP or higher
- PF Series Programmer
- Flat ribbon cable (8-conductor)
- Mini USB cable

7 Setting Up and Using the Hardware

1. Insert the PF0x00 chip into the socket U1. Make sure pin 1 is correctly located on the top-left corner of the socket as shown in [Figure 3](#).

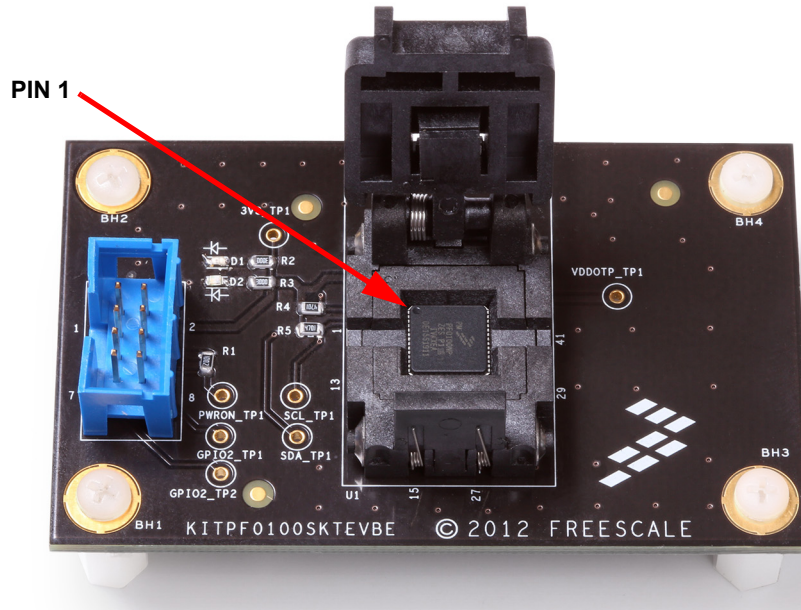

Figure 3. PF0x00 Pin 1 Location

2. Connect the communication ribbon cable (not included) on J1. [Figure 4](#) shows the correct signal allocation from the PF Programmer (KITPFGMEVME) to the KITPF0100SKTEVBE socket board.

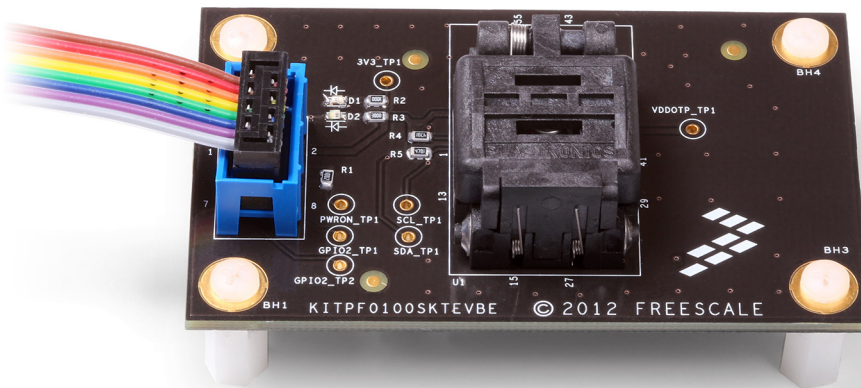
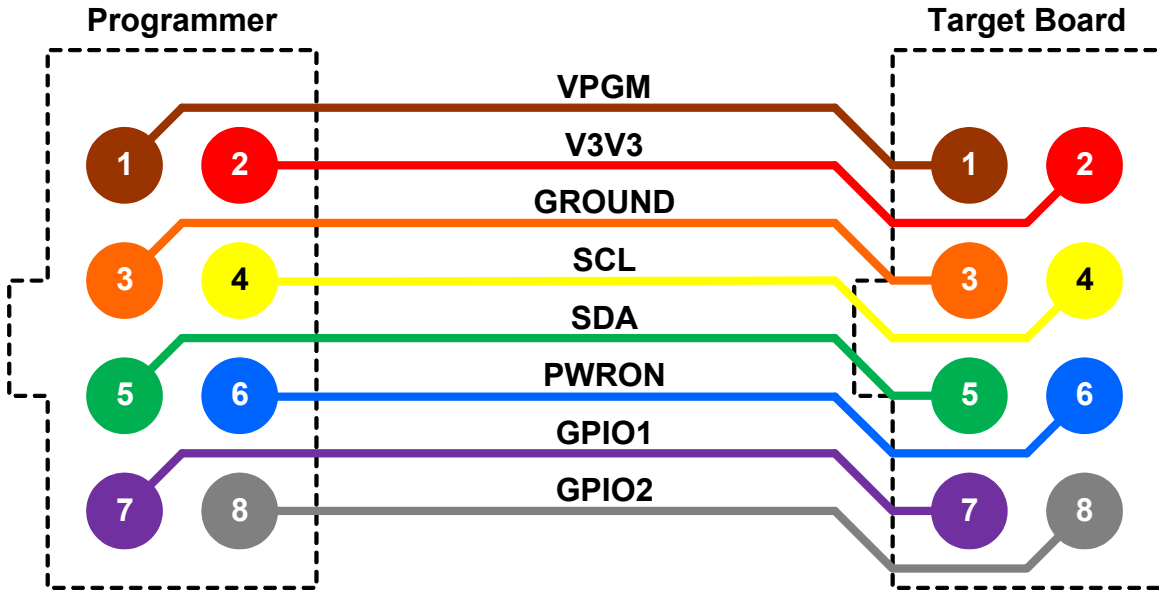
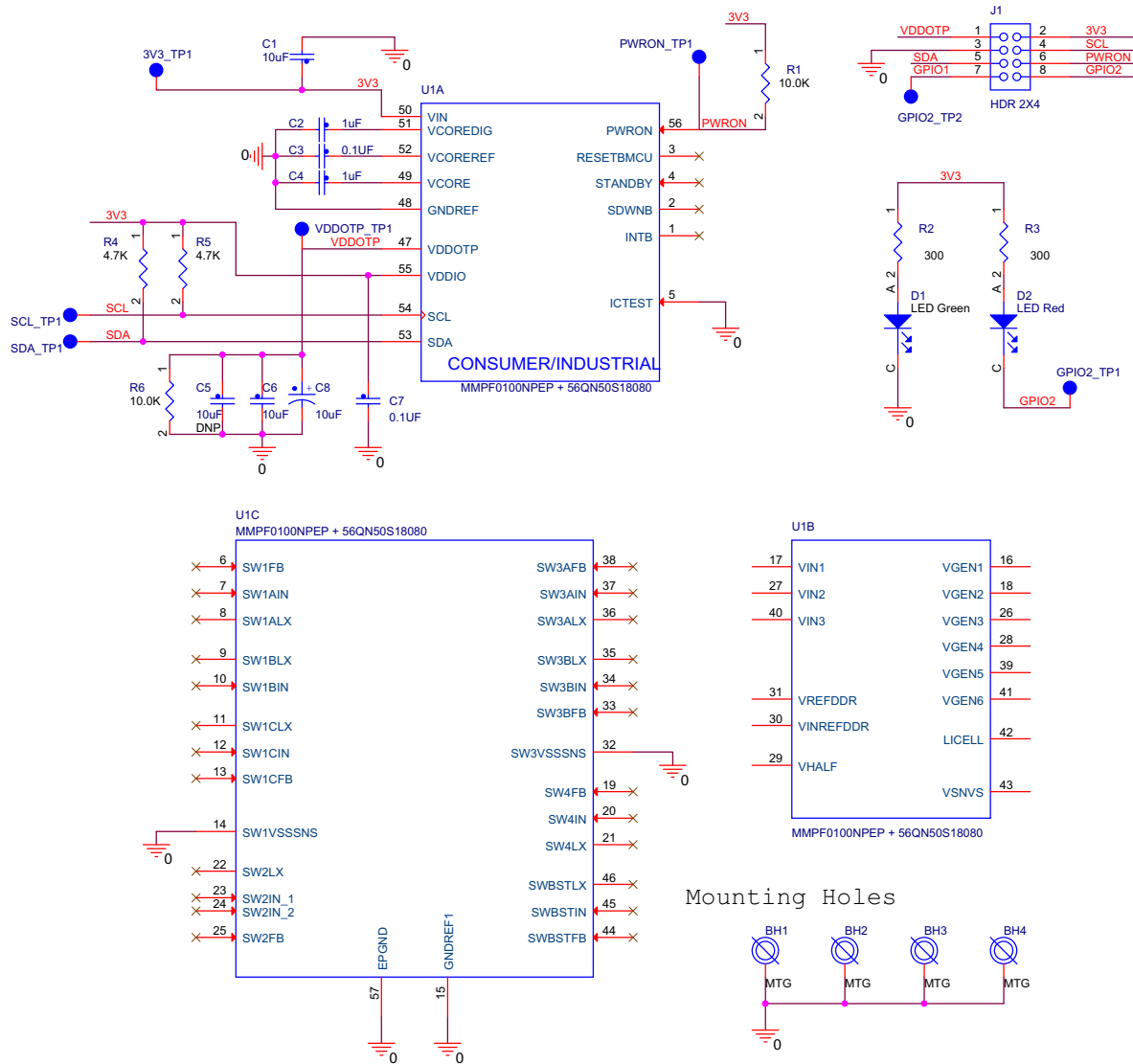

Figure 4. KITPF0100SKTEVBE Connection Diagram

3. Follow the programming procedure outlined in the user's guide "KITPFGMEVME Programmer for PF Series Devices" (document number KTFPFGMEVMEUG). See the ["References"](#) section for details on this document as well as related resources.

8 Schematic



9 Board Layout

9.1 Assembly Layer Top

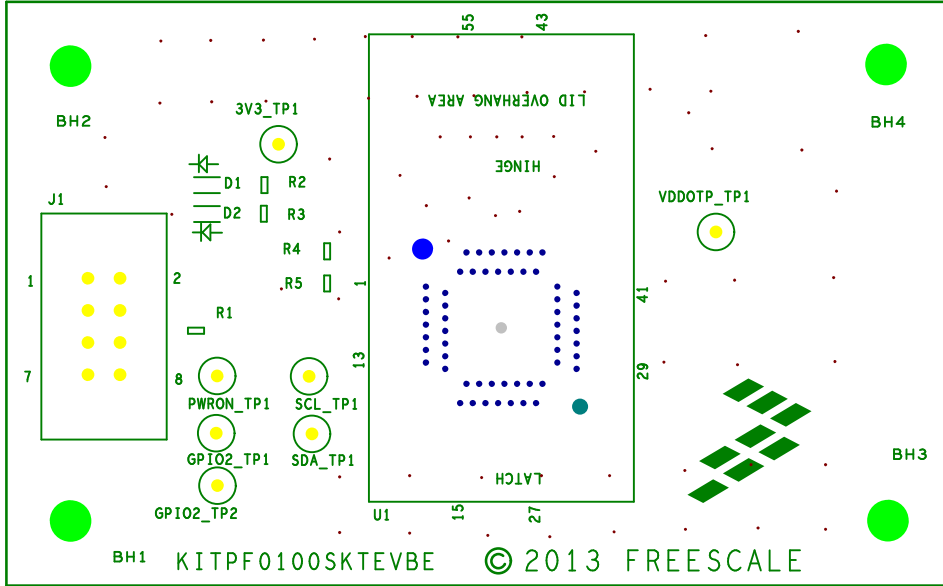

9.2 Assembly Layer Bottom

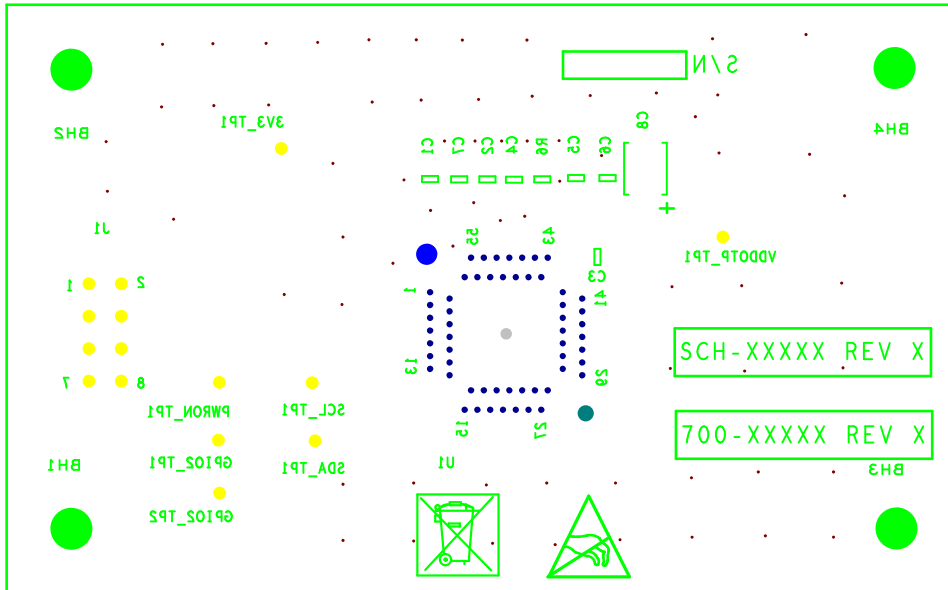

9.3 Top Layer Routing

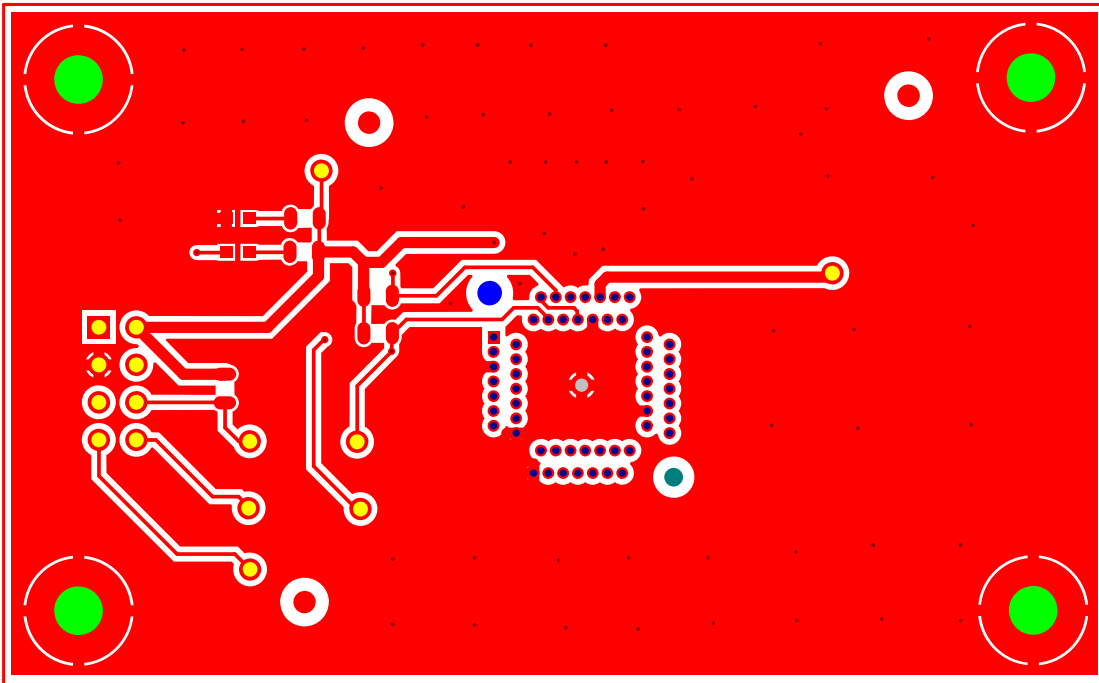

9.4 Bottom Layer Routing

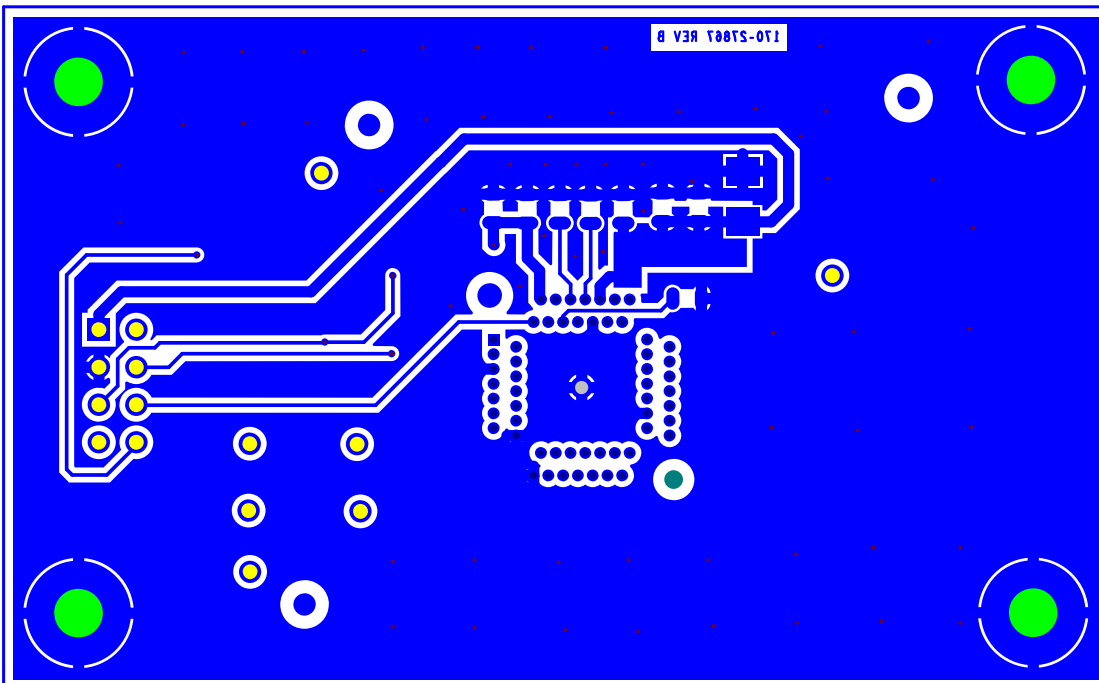

10 References

Document Number and Description		URL
MMPF0100	Data sheet	http://www.freescale.com/files/analog/doc/data_sheet/MMPF0100.pdf
MMPF0100ER	Errata	http://www.freescale.com/files/analog/doc/errata/MMPF0100ER.pdf
PFSERIESFS	Fact Sheet	http://www.freescale.com/files/analog/doc/fact_sheet/PFSeriesFS.pdf
KTPFPGMEVMEUG	User's Guide	http://www.freescale.com/files/analog/doc/user_guide/KTPFPGMEVMEUG.pdf
Freescale.com Support Pages		URL
Product Summary Page		http://www.freescale.com/webapp/sps/site/prod_summary.jsp?code=MMPF0100
Power Management Home Page		http://www.freescale.com/PMIC
Analog Home Page		http://www.freescale.com/analog

11 Revision History

Revision	Date	Description of Changes
1.0	6/2013	Initial Release



How to Reach Us:

Home Page:

freescale.com

Web Support:

freescale.com/support

Information in this document is provided solely to enable system and software implementers to use Freescale products. There are no express or implied copyright licenses granted hereunder to design or fabricate any integrated circuits based on the information in this document.

Freescale reserves the right to make changes without further notice to any products herein. Freescale makes no warranty, representation, or guarantee regarding the suitability of its products for any particular purpose, nor does Freescale assume any liability arising out of the application or use of any product or circuit, and specifically disclaims any and all liability, including without limitation consequential or incidental damages. "Typical" parameters that may be provided in Freescale data sheets and/or specifications can and do vary in different applications, and actual performance may vary over time. All operating parameters, including "typicals," must be validated for each customer application by customer's technical experts. Freescale does not convey any license under its patent rights nor the rights of others. Freescale sells products pursuant to standard terms and conditions of sale, which can be found at the following address: freescale.com/SalesTermsandConditions.

Freescale and the Freescale logo are trademarks of Freescale Semiconductor, Inc., Reg. U.S. Pat. & Tm. Off. All other product or service names are the property of their respective owners.

© 2013 Freescale Semiconductor, Inc.

Document Number: KTPF0100SKTUG
Rev. 1.0
6/2013

