



Chipsmall Limited consists of a professional team with an average of over 10 year of expertise in the distribution of electronic components. Based in Hongkong, we have already established firm and mutual-benefit business relationships with customers from,Europe,America and south Asia,supplying obsolete and hard-to-find components to meet their specific needs.

With the principle of “Quality Parts,Customers Priority,Honest Operation,and Considerate Service”,our business mainly focus on the distribution of electronic components. Line cards we deal with include Microchip,ALPS,ROHM,Xilinx,Pulse,ON,Everlight and Freescale. Main products comprise IC,Modules,Potentiometer,IC Socket,Relay,Connector.Our parts cover such applications as commercial,industrial, and automotives areas.

We are looking forward to setting up business relationship with you and hope to provide you with the best service and solution. Let us make a better world for our industry!



## Contact us

Tel: +86-755-8981 8866 Fax: +86-755-8427 6832

Email & Skype: info@chipsmall.com Web: www.chipsmall.com

Address: A1208, Overseas Decoration Building, #122 Zhenhua RD., Futian, Shenzhen, China





# KMZ60

## Angle sensor with integrated amplifier

Rev. 2 — 7 February 2014

Product data sheet

## 1. Product profile

### 1.1 General description

The MagnetoResistive (MR) sensor with integrated amplifier is designed for angular control applications and BrushLess DC (BLDC) motors with even-numbered pole pairs. It consists of two microchips within one package, an angle sensor and an amplifier Integrated Circuit (IC). The circuit delivers cosine and sine output signals related to the angle of a rotating magnetic field. The output voltage range is ratiometric related to the supply voltage. The Temperature Coefficient (TC) of the sensor amplitude can be compensated. A ratiometric output voltage linear to the temperature is delivered. A Power-down mode is implemented.

### 1.2 Features and benefits

- High precision sensor for magnetic angle measurement
- Single-ended cosine and sine outputs
- Ratiometric output voltages
- $T_{amb} = -40\text{ °C to }+150\text{ °C}$
- Temperature compensated output signal amplitude
- Temperature related ratiometric reference voltage
- Power-down mode to enable or disable the device
- Single package angle sensor with integrated instrumentation amplifier
- RoHS compliant and free of halogen and antimony (Dark Green compliant)

### 1.3 Applications

The KMZ60 angle sensor is dedicated for rotor position detection for BLDC motors. Beyond that the KMZ60 is applicable for Electronic Power Steering (EPS) applications, steering angle measurement, window wiper position detection and general contactless angular measurement (e.g. throttle valves or actuators). The KMZ60 is fully automotive qualified as well as applicable for industrial and consumer applications.

Typical applications:

- BLDC motor (e.g. EPS)
- Window wiper position detection
- Steering angle measurement
- General contactless angular measurement (e.g. throttle valves or actuators)
- Automotive, industrial and consumer applications



## 1.4 Quick reference data

Table 1. Quick reference data

Symbol	Parameter	Conditions	Min	Typ	Max	Unit
$V_{CC}$	supply voltage		2.7	-	5.5	V
$n_H$	magnetic field rotational frequency		0	-	25000	r/min
$H_{ext}$	external magnetic field strength		[1] 25	-	-	kA/m
$\Delta\alpha$	angular inaccuracy	within a static field	[2] -0.1	-	+0.1	deg
$C_{block(ext)}$	external blocking capacitance		[3] 100	-	-	nF
$R_{L(o)ext}$	external output load resistance	on pin VOUT1 and pin VOUT2	[4] 5	-	$\infty$	k $\Omega$
$C_{L(o)ext}$	external output load capacitance		[5] 0.5	-	10	nF

- [1] Induced voltage from a rotating strong magnetic field may impact the performance but without damage.
- [2] Value calculated only with third and fifth harmonic of the spectrum of output signal amplitude  $V_{o(VOUT1)}$  and  $V_{o(VOUT2)}$  by ideal homogeneous field.
- [3] Between pin  $V_{CC}$  and pin GND, soldered close to the package.
- [4] Operating as sink or source.
- [5] Between pin VOUT1 and pin  $V_{CC}$  or pin GND and between pin VOUT2 and pin  $V_{CC}$  or pin GND.

## 2. Pinning information

Table 2. Pinning

Pin	Symbol	Description	Simplified outline
1	TCC_EN	temperature coefficient compensation enable	
2	VOUT1	cosine channel output	
3	GND	ground	
4	VOUT2	sine channel output	
5	VTEMP	temperature reference output voltage	
6	GND	ground	
7	$V_{CC}$	supply voltage	
8	POWERDOWN_EN	Power-down mode enable	

## 3. Ordering information

Table 3. Ordering information

Type number	Package		
	Name	Description	Version
KMZ60	SO8	plastic small outline package; 8 leads; body width 3.9 mm	SOT96-1

### 4. Functional diagram

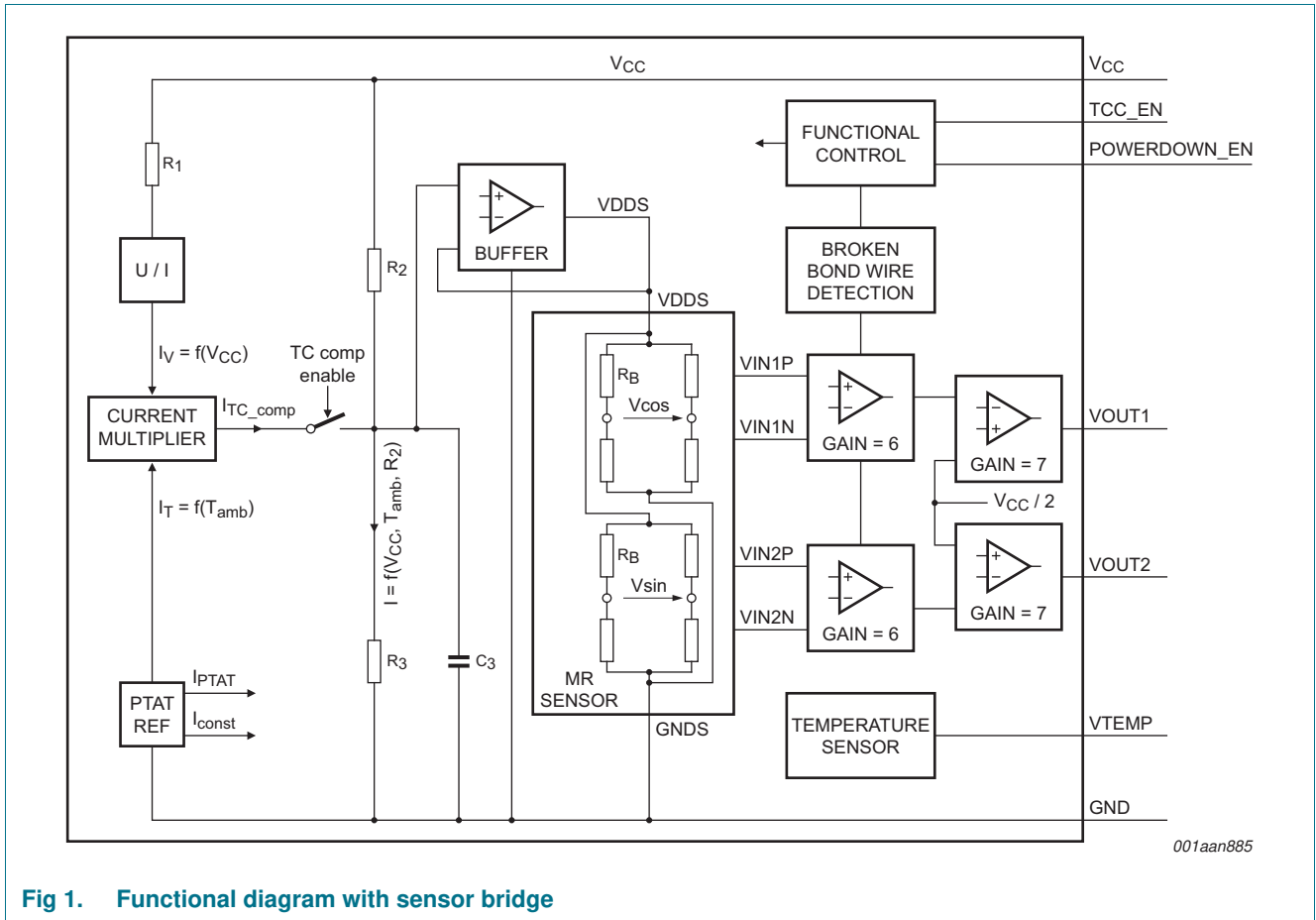

Fig 1. Functional diagram with sensor bridge

### 5. Functional description

Figure 1 shows the complete circuit consisting of the MR sensor element realized by two interleaved Wheatstone bridges for cosine and sine signals. Also the supporting functions for control circuit and signal amplification are included. A Proportional To Absolute Temperature (PTAT) reference current, a voltage-to-current converter and a current multiplier are generating the reference current which is supply voltage, temperature and resistor dependent. This reference current controls the supply voltage of both sensor bridges to compensate their TC via a supply buffer. For noise and ElectroMagnetic Compatibility (EMC) suppression low-pass filtering of the bridge supply is implemented. The bridge output voltages are amplified by a constant factor and fed to the rail-to-rail output buffers. The single-ended outputs are capable to drive inputs e.g. of an external Analog-to-Digital Converter (ADC) referenced to  $V_{CC}$ . For an optimal use of the ADC input range the cosine and sine output voltages are tracking ratiometric with the supply voltage. To achieve good signal performance, both signals are matched in amplitude and phase. The amplifier bandwidth is sufficient for low phase delay at maximum specified speed of rotation. Pin TCC\_EN is used to enable the temperature compensation. Two modes are defined. The TC of the MR sensor signal amplitude is largely compensated by the amplifier if pin TCC\_EN is connected to  $V_{CC}$ . The amplified sensor signal, which has a negative TC, is available at the output pins VOUT1 and VOUT2 if pin TCC\_EN is

connected to ground. Pin VTEMP delivers a temperature dependent output voltage  $V_{O(TEMP)}$  in both cases, which is tracking ratiometric with the supply voltage. It uses the internal PTAT reference and can be left open or connected to ground or preferably to  $V_{CC}$  if not used. The pin POWERDOWN\_EN input switches the device into Power-down mode and sets the pin VOUT1 and pin VOUT2 output to high impedance and disables pin VTEMP. It must be connected to ground if not used. An implemented broken bond wire detection for all internal connections to the MR sensor is drawing the output voltages  $V_{O(VOUT1)}$  and  $V_{O(VOUT2)}$  to the ground level in case of a failure. Both outputs are short-circuit proof.

The integrated MR sensor element is a sensitive magnetic field sensor, employing the MR effect of thin film permalloy. The sensor contains two parallel supplied Wheatstone bridges, which enclose a sensitive angle of 45 degrees. A rotating magnetic field in the surface parallel to the chip (x-y plane) will deliver two independent sinusoidal output signals, one following a  $\cos(2\alpha)$  and the second following a  $\sin(2\alpha)$  function.  $\alpha$  is the mechanical angle between sensor and field direction.

The definition of the output signal amplitude  $V_{O(VOUT1)}$  and  $V_{O(VOUT2)}$  and the output offset voltage  $V_{offset(VOUT1)}$  and  $V_{offset(VOUT2)}$  of KMZ60 for a mechanical angle of 360 degrees is shown in [Figure 2](#).

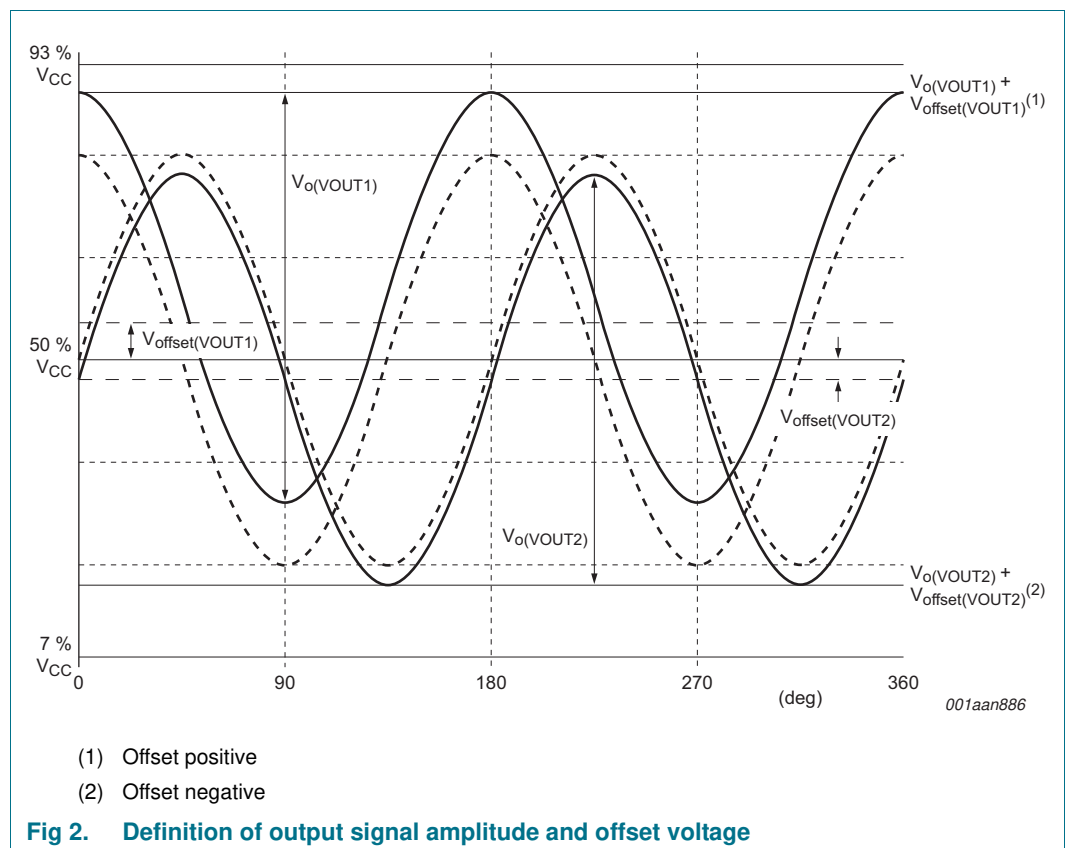

## 6. Internal circuitry

Table 4. Internal circuits for each pin

Symbol	Pin	Equivalent circuit
--------	-----	--------------------

TCC_EN	1	
--------	---	--

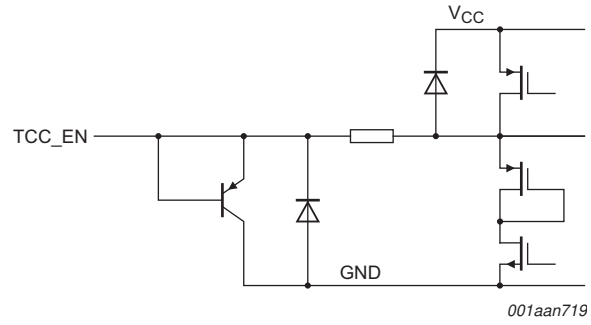

VOUT1	2
GND	3 and 6
VOUT2	4

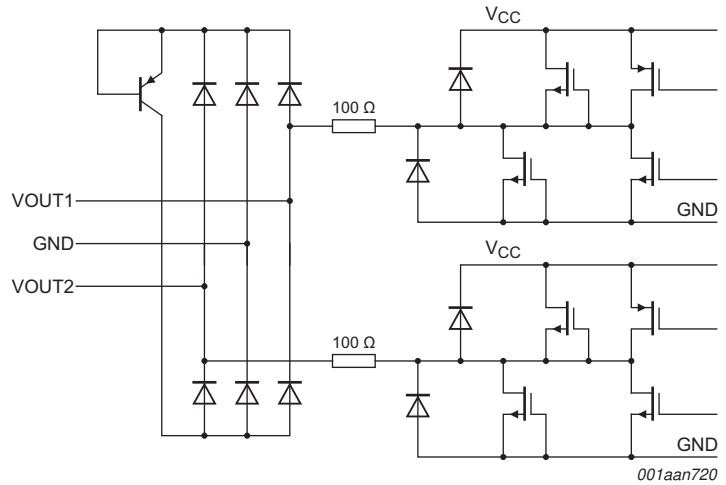

Table 4. Internal circuits for each pin ...continued

Symbol	Pin	Equivalent circuit
VTEMP	5	
V <sub>CC</sub>	7	
POWERDOWN_EN	8	

## 7. Limiting values

Table 5. Limiting values

In accordance with the Absolute Maximum Rating System (IEC 60134).

Symbol	Parameter	Conditions	Min	Max	Unit
V <sub>CC</sub>	supply voltage		-0.3	+6	V
V <sub>I</sub>	input voltage	on pins TCC_EN and POWERDOWN_EN	-0.3	V <sub>CC</sub> + 0.3	V
V <sub>O</sub>	output voltage	on pins VOUT1, VOUT2 and VTEMP	-0.3	V <sub>CC</sub> + 0.3	V
T <sub>amb</sub>	ambient temperature		-40	+160	°C

## 8. Recommended operating conditions

**Table 6. Operating conditions**

Symbol	Parameter	Conditions	Min	Max	Unit
$V_{CC}$	supply voltage		2.7	5.5	V
$T_{amb}$	ambient temperature		-40	+150	°C

## 9. Characteristics

**Table 7. Characteristics**

$T_{amb} = 25\text{ °C}$ ; angle accuracies referred to homogeneous excitation magnetic fields of  $H_{ext} = 25\text{ kA/m}$  directed parallel to MR sensor surface; all voltages are related to ground potential of pin GND; the signal outputs and offset voltages on pin VOUT1 and pin VOUT2 are related to the common mode level of  $V_{CC} / 2$ ; unless otherwise specified.

Symbol	Parameter	Conditions	Min	Typ	Max	Unit
$V_{CC}$	supply voltage		2.7	-	5.5	V
$I_{CC}$	supply current	under normal condition dependent on $V_{CC}$ , $R_{L(o)ext}$ and rotation frequency; no short-circuit of outputs	2.0	6.0	10.0	mA
		Power-down mode; $V_{CC}$ on pin POWERDOWN_EN; $V_{CC}$ or ground on pin TCC_EN	-	-	16	μA
$I_{pu}$	pull-up current	pin TCC_EN to ground	-5	-	-0.3	μA
$I_{pd}$	pull-down current	$V_{CC}$ on pin POWERDOWN_EN	0.01	-	3	μA
$C_{block(ext)}$	external blocking capacitance		<a href="#">11</a> 100	-	-	nF
$R_{sc}$	short-circuit resistance	pin TCC_EN to $V_{CC}$ or ground	-	-	10	Ω
$R_o$	output resistance	on pin VOUT1, pin VOUT2 and pin VTEMP	50	-	150	Ω
		on pin VOUT1 and pin VOUT2; $V_{CC}$ on pin POWERDOWN_EN	500	-	-	kΩ
		pin VTEMP to ground; $V_{CC}$ on pin POWERDOWN_EN	35	-	85	kΩ
$R_{L(o)ext}$	external output load resistance	on pin VOUT1 and pin VOUT2	<a href="#">12</a> 5	-	∞	kΩ
		pin VTEMP to ground	20	-	100	kΩ
$C_{L(o)ext}$	external output load capacitance	on pin VOUT1 and pin VOUT2	<a href="#">13</a> 0.5	-	10	nF
		on pin VTEMP	22	33	39	nF
$V_o$	output voltage	on pin VOUT1 and pin VOUT2; without signal clipping; $R_{L(o)ext} = 5\text{ kΩ}$	$0.07V_{CC}$	-	$0.93V_{CC}$	V
$V_{OL}$	LOW-level output voltage	on pin VOUT1 and pin VOUT2; broken bond wire detected; $R_{L(o)ext} = 5\text{ kΩ}$ to ground	-	-	$0.05V_{CC}$	V
		on pin VOUT1 and pin VOUT2; broken bond wire detected; $R_{L(o)ext} = 5\text{ kΩ}$ to $V_{CC}$	-	-	$0.06V_{CC}$	V



**Table 7. Characteristics ...continued**

$T_{amb} = 25\text{ °C}$ ; angle accuracies referred to homogeneous excitation magnetic fields of  $H_{ext} = 25\text{ kA/m}$  directed parallel to MR sensor surface; all voltages are related to ground potential of pin GND; the signal outputs and offset voltages on pin VOUT1 and pin VOUT2 are related to the common mode level of  $V_{CC} / 2$ ; unless otherwise specified.

Symbol	Parameter	Conditions	Min	Typ	Max	Unit
$I_{sc}$	short-circuit current	to ground; on pin VOUT1 and pin VOUT2	[4] -6	-	-	mA
		to ground; on pin VTEMP	[4] -2	-	-	mA
		to $V_{CC}$ ; on pin VOUT1 and pin VOUT2	[5] -	-	6	mA
		to $V_{CC}$ ; on pin VTEMP	[5] -	-	2	mA
$C_{L(i)ext}$	external input load capacitance	on pin POWERDOWN_EN for ElectroMagnetic Interference (EMI) reason	100	-	-	nF
$V_{IL}$	LOW-level input voltage	on pin POWERDOWN_EN	-	-	0.6	V
$V_{IH}$	HIGH-level input voltage	on pin POWERDOWN_EN	$V_{CC} - 0.6$	-	-	V
$t_{startup}$	start-up time	to 98 % of $V_{o(VOUT1)}$ or $V_{o(VOUT2)}$ end level after minimum $V_{CC}$ was reached	-	-	110	$\mu$ s
		from power-down to 98 % of $V_{o(VOUT1)}$ or $V_{o(VOUT2)}$ end level	-	-	110	$\mu$ s
$H_{ext}$	external magnetic field strength		[6] 25	-	-	kA/m
$\Phi_{err}$	reference position angle error		[7] -2	-	+2	deg
$\Phi_{startup}$	start-up angle error	$T_{amb} = -40\text{ °C}$ ; $R_{L(o)ext} = 5\text{ k}\Omega$	-10	-	+10	deg
		$T_{amb} = 25\text{ °C}$ ; $R_{L(o)ext} = 5\text{ k}\Omega$	-10	-	+10	deg
		$T_{amb} = 85\text{ °C}$ ; $R_{L(o)ext} = 5\text{ k}\Omega$	-13	-	+13	deg
		$T_{amb} = 105\text{ °C}$ ; $R_{L(o)ext} = 5\text{ k}\Omega$	-14.5	-	+14.5	deg
		$T_{amb} = 150\text{ °C}$ ; $R_{L(o)ext} = 5\text{ k}\Omega$	-19	-	+19	deg

**Dynamic characteristics for angular accuracy calculations**

$n_H$	magnetic field rotational frequency		0	-	25000	r/min
$k$	amplitude synchronism		[8] 98	-	102	%
$\varphi_{err}$	phase error		[9] -	-	1.5	deg
$\Delta\alpha$	angular inaccuracy	within a static field	[10] -0.1	-	+0.1	deg
PSRR	power supply rejection ratio	$f_{ripple} = 500\text{ kHz}$	12	-	-	dB
$V_{n(o)(RMS)}$	RMS output noise voltage	on pin VOUT1, pin VOUT2 and pin VTEMP; no magnetic signal	[11] -	-	500	$\mu$ V

**Temperature dependency of output on pin VTEMP**

$V_O$	output voltage	$T_{amb} = -40\text{ °C}$	$0.057V_{CC}$	-	$0.147V_{CC}$	V
		$T_{amb} = 25\text{ °C}$	$0.248V_{CC}$	-	$0.351V_{CC}$	V
		$T_{amb} = 85\text{ °C}$	$0.445V_{CC}$	-	$0.559V_{CC}$	V
		$T_{amb} = 105\text{ °C}$	$0.515V_{CC}$	-	$0.631V_{CC}$	V
		$T_{amb} = 150\text{ °C}$	$0.655V_{CC}$	-	$0.786V_{CC}$	V

**Table 7. Characteristics ...continued**

$T_{amb} = 25\text{ °C}$ ; angle accuracies referred to homogeneous excitation magnetic fields of  $H_{ext} = 25\text{ kA/m}$  directed parallel to MR sensor surface; all voltages are related to ground potential of pin GND; the signal outputs and offset voltages on pin VOUT1 and pin VOUT2 are related to the common mode level of  $V_{CC} / 2$ ; unless otherwise specified.

Symbol	Parameter	Conditions	Min	Typ	Max	Unit		
<b>Temperature dependency of signal outputs with TC compensation (<math>V_{CC}</math> on pin TCC_EN)</b>								
$V_o$	output voltage	peak-to-peak value; on pin VOUT1; $R_{L(o)ext} = 5\text{ k}\Omega$						
		$T_{amb} = -40\text{ °C}$	$0.42V_{CC}$	$0.56V_{CC}$	$0.70V_{CC}$	V		
		$T_{amb} = 25\text{ °C}$	$0.46V_{CC}$	$0.56V_{CC}$	$0.70V_{CC}$	V		
		$T_{amb} = 85\text{ °C}$	$0.42V_{CC}$	$0.53V_{CC}$	$0.70V_{CC}$	V		
		$T_{amb} = 105\text{ °C}$	$0.395V_{CC}$	$0.51V_{CC}$	$0.695V_{CC}$	V		
		$T_{amb} = 150\text{ °C}$	$0.35V_{CC}$	$0.48V_{CC}$	$0.68V_{CC}$	V		
		peak-to-peak value; on pin VOUT2; $R_{L(o)ext} = 5\text{ k}\Omega$						
		$T_{amb} = -40\text{ °C}$	$0.42V_{CC}$	$0.56V_{CC}$	$0.70V_{CC}$	V		
		$T_{amb} = 25\text{ °C}$	$0.46V_{CC}$	$0.56V_{CC}$	$0.70V_{CC}$	V		
		$T_{amb} = 85\text{ °C}$	$0.42V_{CC}$	$0.53V_{CC}$	$0.70V_{CC}$	V		
		$T_{amb} = 105\text{ °C}$	$0.395V_{CC}$	$0.51V_{CC}$	$0.695V_{CC}$	V		
		$T_{amb} = 150\text{ °C}$	$0.35V_{CC}$	$0.48V_{CC}$	$0.68V_{CC}$	V		
		$V_{offset}$	offset voltage	on pin VOUT1; $R_{L(o)ext} = 5\text{ k}\Omega$				
				$T_{amb} = -40\text{ °C}$	$-0.08V_{CC}$	-	$+0.08V_{CC}$	V
$T_{amb} = 25\text{ °C}$	$-0.08V_{CC}$			-	$+0.08V_{CC}$	V		
$T_{amb} = 85\text{ °C}$	$-0.09V_{CC}$			-	$+0.09V_{CC}$	V		
$T_{amb} = 105\text{ °C}$	$-0.095V_{CC}$			-	$+0.095V_{CC}$	V		
$T_{amb} = 150\text{ °C}$	$-0.11V_{CC}$			-	$+0.11V_{CC}$	V		
on pin VOUT2; $R_{L(o)ext} = 5\text{ k}\Omega$								
$T_{amb} = -40\text{ °C}$	$-0.08V_{CC}$			-	$+0.08V_{CC}$	V		
$T_{amb} = 25\text{ °C}$	$-0.08V_{CC}$			-	$+0.08V_{CC}$	V		
$T_{amb} = 85\text{ °C}$	$-0.09V_{CC}$			-	$+0.09V_{CC}$	V		
$T_{amb} = 105\text{ °C}$	$-0.095V_{CC}$			-	$+0.095V_{CC}$	V		
$T_{amb} = 150\text{ °C}$	$-0.11V_{CC}$			-	$+0.11V_{CC}$	V		

**Table 7. Characteristics ...continued**

$T_{amb} = 25\text{ }^{\circ}\text{C}$ ; angle accuracies referred to homogeneous excitation magnetic fields of  $H_{ext} = 25\text{ kA/m}$  directed parallel to MR sensor surface; all voltages are related to ground potential of pin GND; the signal outputs and offset voltages on pin VOUT1 and pin VOUT2 are related to the common mode level of  $V_{CC} / 2$ ; unless otherwise specified.

Symbol	Parameter	Conditions	Min	Typ	Max	Unit	
<b>Temperature dependency of signal outputs without TC compensation (pin TCC_EN to ground)</b>							
$V_o$	output voltage	peak-to-peak value; on pin VOUT1; $R_{L(o)ext} = 5\text{ k}\Omega$					
		$T_{amb} = -40\text{ }^{\circ}\text{C}$	$0.54V_{CC}$	$0.66V_{CC}$	$0.76V_{CC}$	V	
		$T_{amb} = 25\text{ }^{\circ}\text{C}$	$0.41V_{CC}$	$0.49V_{CC}$	$0.57V_{CC}$	V	
		$T_{amb} = 85\text{ }^{\circ}\text{C}$	$0.31V_{CC}$	$0.37V_{CC}$	$0.45V_{CC}$	V	
		$T_{amb} = 105\text{ }^{\circ}\text{C}$	$0.275V_{CC}$	$0.34V_{CC}$	$0.425V_{CC}$	V	
		$T_{amb} = 150\text{ }^{\circ}\text{C}$	$0.21V_{CC}$	$0.27V_{CC}$	$0.36V_{CC}$	V	
		peak-to-peak value; on pin VOUT2; $R_{L(o)ext} = 5\text{ k}\Omega$					
		$T_{amb} = -40\text{ }^{\circ}\text{C}$	$0.54V_{CC}$	$0.66V_{CC}$	$0.76V_{CC}$	V	
		$T_{amb} = 25\text{ }^{\circ}\text{C}$	$0.41V_{CC}$	$0.49V_{CC}$	$0.57V_{CC}$	V	
		$T_{amb} = 85\text{ }^{\circ}\text{C}$	$0.31V_{CC}$	$0.37V_{CC}$	$0.45V_{CC}$	V	
		$T_{amb} = 105\text{ }^{\circ}\text{C}$	$0.275V_{CC}$	$0.34V_{CC}$	$0.425V_{CC}$	V	
		$T_{amb} = 150\text{ }^{\circ}\text{C}$	$0.21V_{CC}$	$0.27V_{CC}$	$0.36V_{CC}$	V	
$V_{offset}$	offset voltage	on pin VOUT1; $R_{L(o)ext} = 5\text{ k}\Omega$					
		$T_{amb} = -40\text{ }^{\circ}\text{C}$	$-0.07V_{CC}$	-	$+0.07V_{CC}$	V	
		$T_{amb} = 25\text{ }^{\circ}\text{C}$	$-0.07V_{CC}$	-	$+0.07V_{CC}$	V	
		$T_{amb} = 85\text{ }^{\circ}\text{C}$	$-0.07V_{CC}$	-	$+0.07V_{CC}$	V	
		$T_{amb} = 105\text{ }^{\circ}\text{C}$	$-0.075V_{CC}$	-	$+0.075V_{CC}$	V	
		$T_{amb} = 150\text{ }^{\circ}\text{C}$	$-0.08V_{CC}$	-	$+0.08V_{CC}$	V	
		on pin VOUT2; $R_{L(o)ext} = 5\text{ k}\Omega$					
		$T_{amb} = -40\text{ }^{\circ}\text{C}$	$-0.07V_{CC}$	-	$+0.07V_{CC}$	V	
		$T_{amb} = 25\text{ }^{\circ}\text{C}$	$-0.07V_{CC}$	-	$+0.07V_{CC}$	V	
		$T_{amb} = 85\text{ }^{\circ}\text{C}$	$-0.07V_{CC}$	-	$+0.07V_{CC}$	V	
		$T_{amb} = 105\text{ }^{\circ}\text{C}$	$-0.075V_{CC}$	-	$+0.075V_{CC}$	V	
		$T_{amb} = 150\text{ }^{\circ}\text{C}$	$-0.08V_{CC}$	-	$+0.08V_{CC}$	V	

- [1] Between pin  $V_{CC}$  and pin GND, soldered close to the package.
- [2] Operating as sink or source.
- [3] Between pin VOUT1 and pin  $V_{CC}$  or pin GND and between pin VOUT2 and pin  $V_{CC}$  or pin GND.
- [4] Short-circuit to pin GND within a time limit of 10 minutes.
- [5] Short-circuit to pin  $V_{CC}$  within a time limit of 10 minutes.
- [6] Induced voltage from a rotating strong magnetic field may impact the performance but without damage.
- [7] Angle error due to reference position defined by the leadframe, sample based controlled at assembly line.
- [8] By calculation of peak-to-peak amplitude relation  $k = 100 \times V_{o(VOUT1)} / V_{o(VOUT2)}$ .
- [9] Rotation frequency dependent phase error, after offset correction, amplitude calibration and arctangent calculation.
- [10] Value calculated only with third and fifth harmonic of the spectrum of output signal amplitude  $V_{o(VOUT1)}$  and  $V_{o(VOUT2)}$  by ideal homogeneous field.
- [11] Maximum limit is valid with external first order filter of 80 kHz.

## 10. Definitions of errors

### 10.1 Reference position angle error

The reference position angle error  $\Phi_{err}$  is defined as absolute mounting position deviation of the MR sensor in a homogeneous excitation magnetic field related to the reference position  $\Phi_0$  defined by the leadframe. Marking position for angle  $\Phi_0 = 0$  degree and  $Y = 0$  position is referred parallel to the straight connection line of the 2nd and 7th package pin. The  $X = 0$  position is referred to the middle distance of the package top (see [Figure 3](#)).

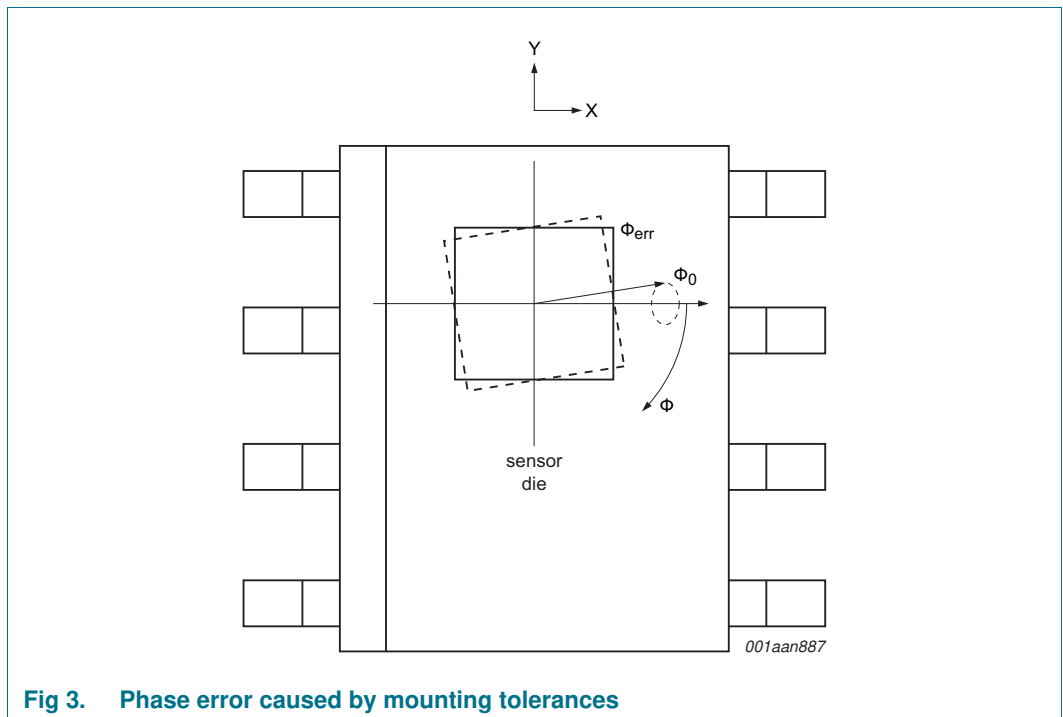
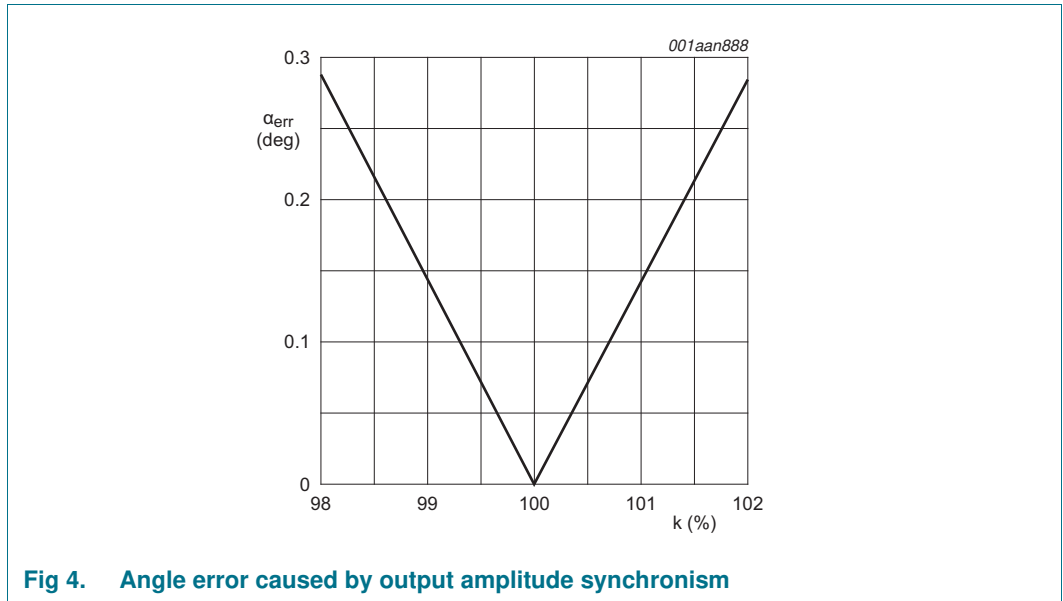

Fig 3. Phase error caused by mounting tolerances

### 10.2 Output amplitude matching error

The output amplitude matching error  $k$  is defined as the relation between both output channel amplitudes at continuously rotating magnetic excitation of the MR sensor.

$$k = 100 \times V_{o(VOUT1)} (p-p) / V_{o(VOUT2)} (p-p) \text{ (the angle error can be derived from [Figure 4](#))}$$



### 10.3 Output signal amplitude

The peak-to-peak output signal amplitude of  $V_o(V_{OUT1})$  and  $V_o(V_{OUT2})$  is related to  $V_{CC}$ . [Figure 5](#) and [Figure 6](#) show the specified amplitude range over temperature within its minimum and maximum limits.

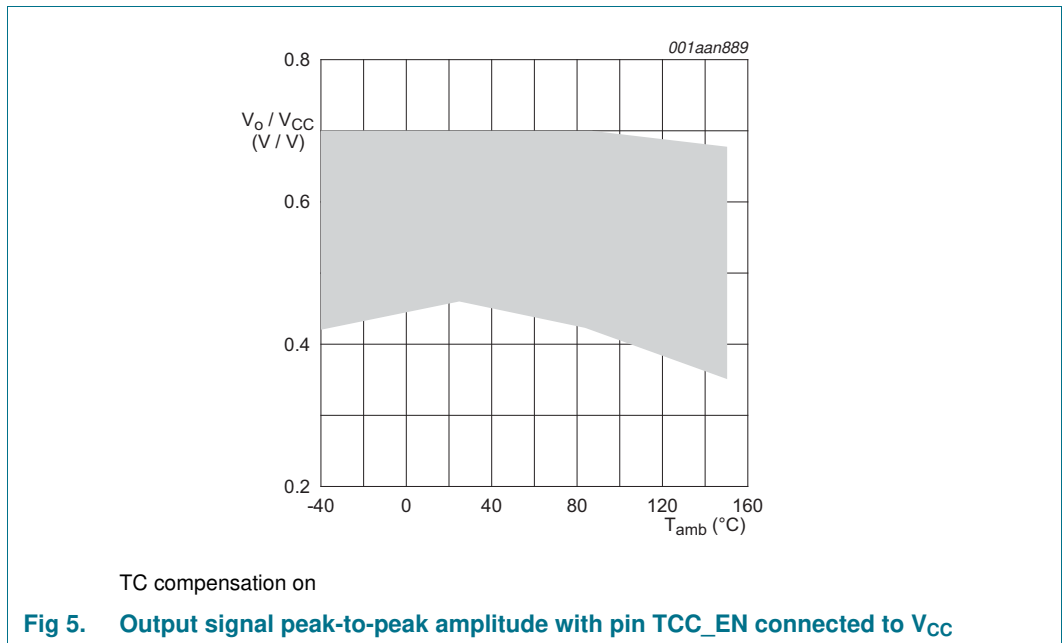

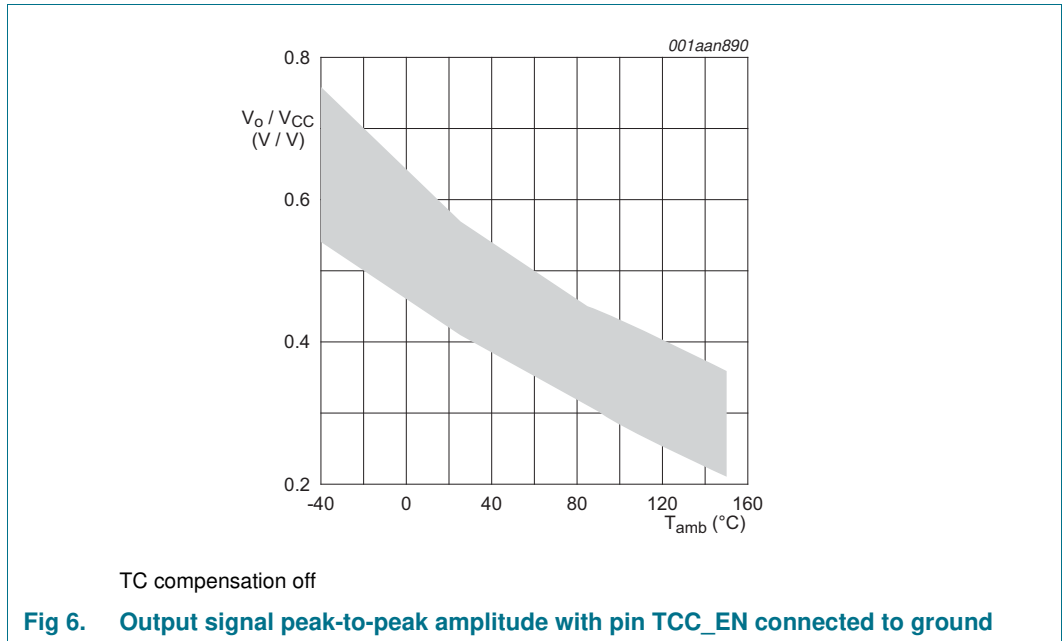

### 10.4 TC of output signal amplitude

The TC of the peak-to-peak output signal amplitude of  $V_{o(VOUT1)}$  and  $V_{o(VOUT2)}$  is related to  $V_{CC}$ . [Figure 7](#) and [Figure 8](#) show the specified TC range of the amplitude over temperature within its minimum and maximum limits. The limits were calculated from single MR sensor measurements and circuit measurements.

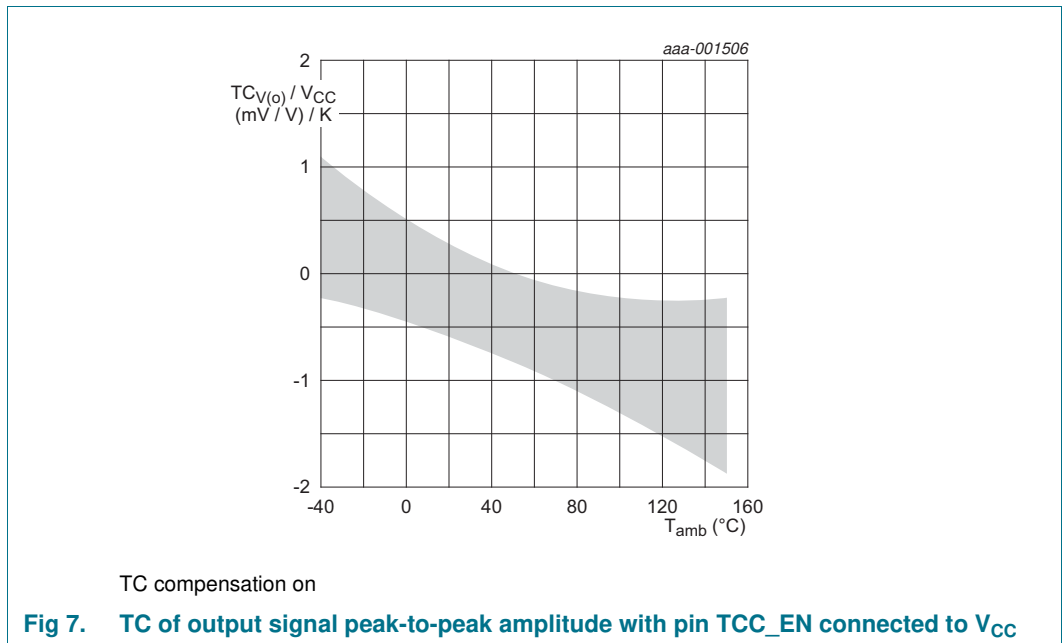

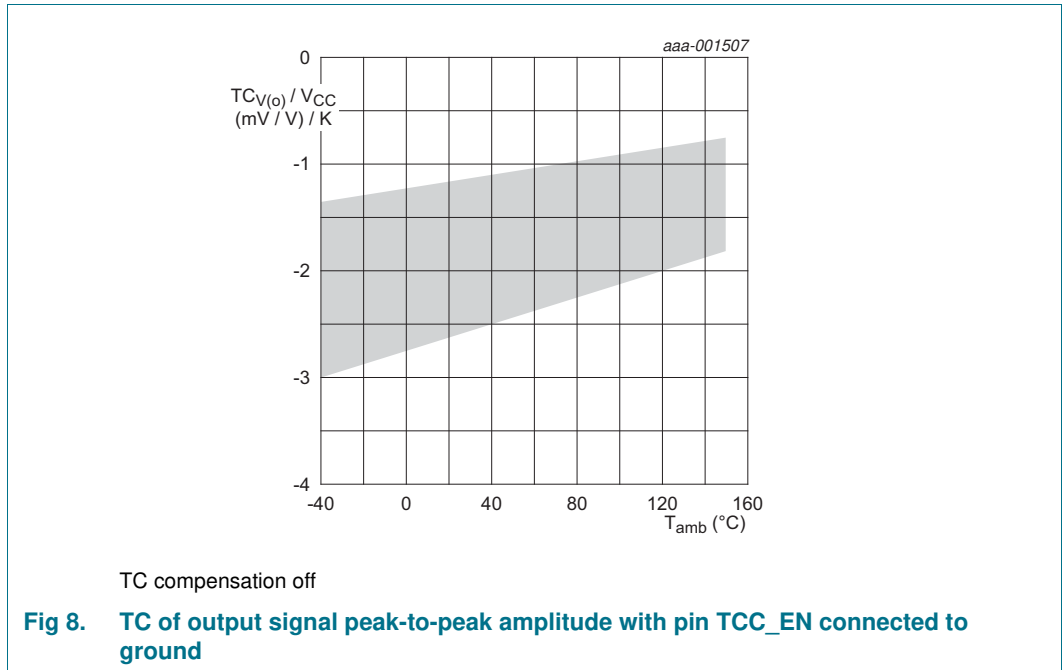

### 10.5 TC of output signal offset

The TC of the output signal offset of  $V_{\text{offset}}(\text{VOUT1})$  and  $V_{\text{offset}}(\text{VOUT2})$  is related to  $V_{\text{CC}}$ . [Figure 9](#) and [Figure 10](#) show the specified TC range of the offset over temperature within its minimum and maximum limits. The limits were calculated from single MR sensor measurements and circuit measurements.

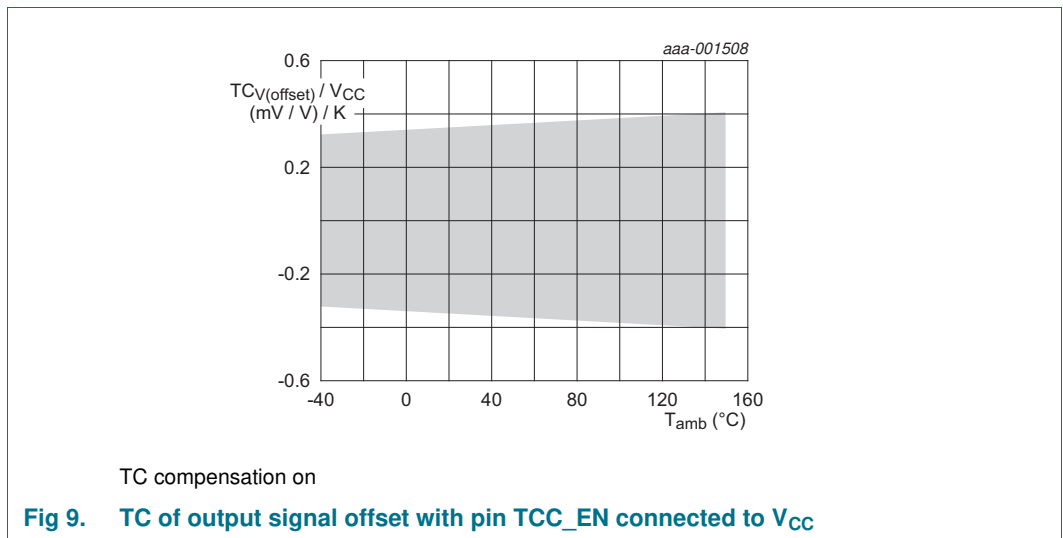

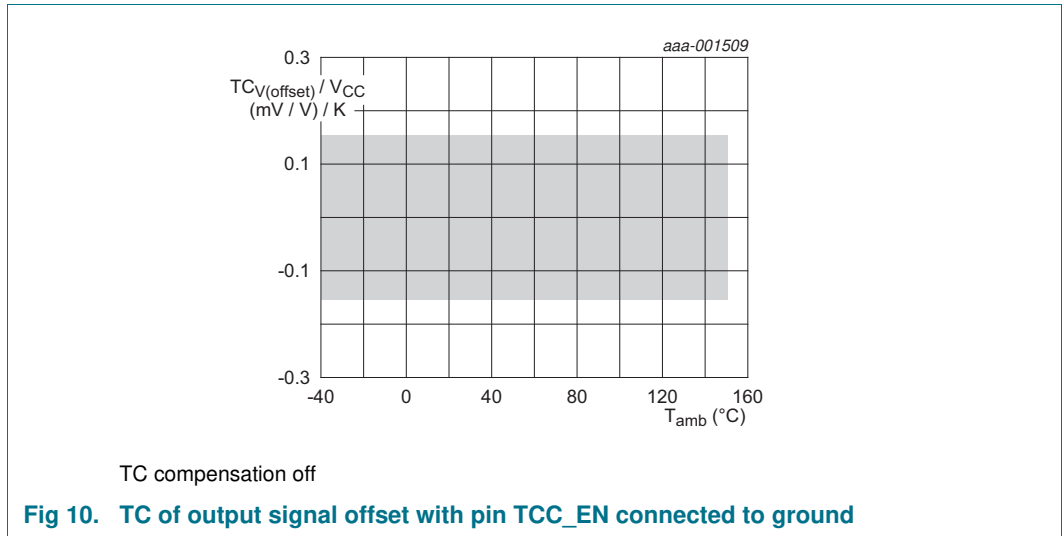

### 10.6 Start-up angle error

The start-up angle error is defined as maximum deviation by calculating the angle from the offset voltages  $V_{offset}(VOUT1)$  and  $V_{offset}(VOUT2)$  and the peak-to-peak signal amplitudes  $V_{o}(VOUT1)$  and  $V_{o}(VOUT2)$ .

Figure 11 and Figure 12 show the maximum start-up angular error related to 180 degree angular range of the MR sensor after one point calibration at 25 °C (from worst case simulations).

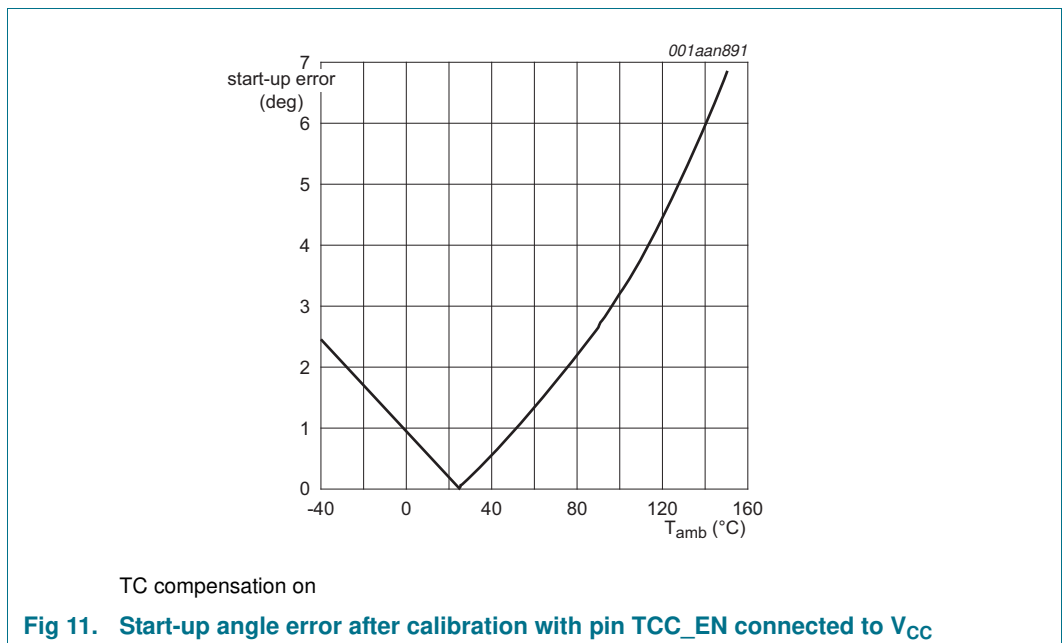



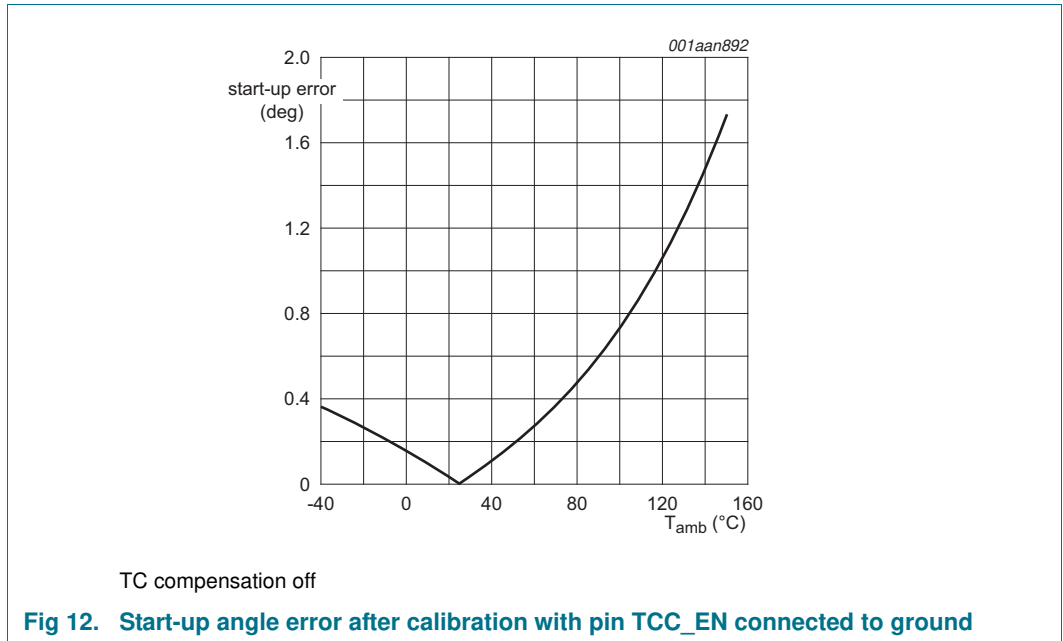

### 10.7 Phase error

The phase error  $\varphi_{err}$  is defined as a rotation frequency dependent error due to bandwidth limitation of the operational amplifiers.  $V_{o(VOUT1)}$  and  $V_{o(VOUT2)}$  are retarded by the device propagation delay, referred to the actual angle direction of the rotating magnetic field (see [Figure 13](#)). The typical characteristics value can be used for a 1st order compensation of this error on very high rotations per minute. For low rotational speed systems this error component is negligible.

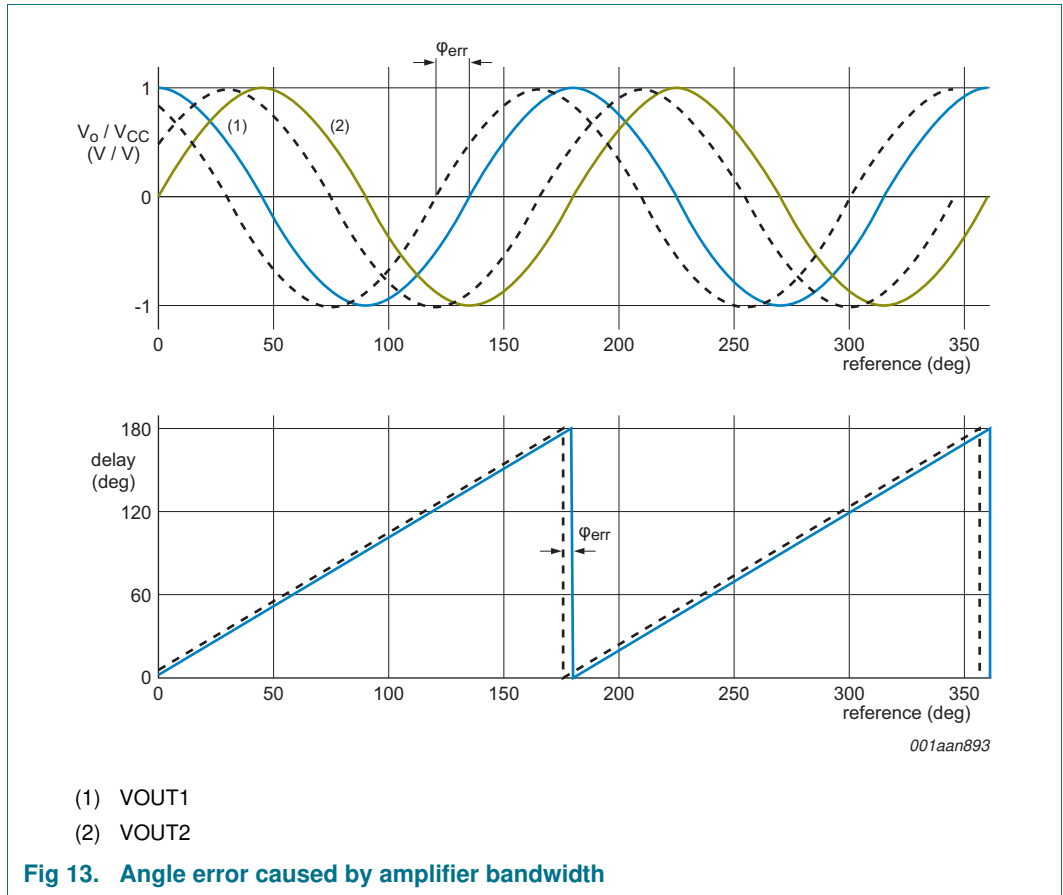

### 10.8 Temperature behavior of pin VTEMP output

The temperature dependent  $V_{O(TEMP)}$  reference voltage with its specified tolerances is shown in [Figure 14](#). The output level is related to ground and tracking ratiometric with  $V_{CC}$ . Stability is guaranteed at the specified output load.

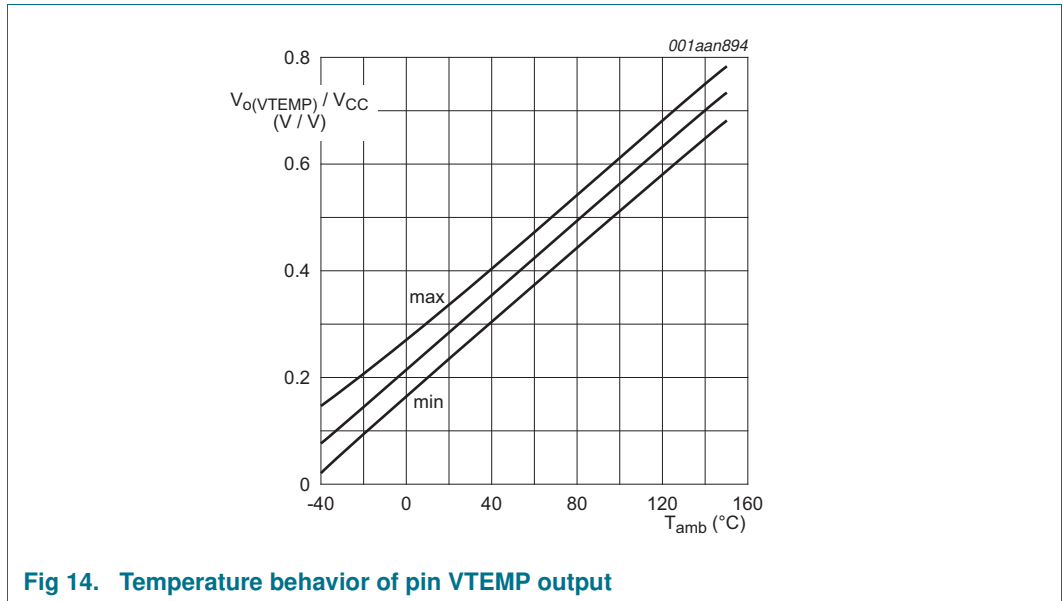

Fig 14. Temperature behavior of pin VTEMP output

## 11. Electromagnetic compatibility

### 11.1 Emission (IEC 61967-4)

EMC tests carried out according to IEC 61967-4, part 4 under typical specification conditions at  $V_{CC} = 5\text{ V}$  without rotational field excitation. Pin TCC\_EN connected to  $V_{CC}$  or ground.

Direct coupling method:  $150\ \Omega$ ,  $6.8\text{ nF}$ , frequency band 150 kHz to 1 GHz

Test severity limit: Class III local with level 10-K

Test ensured on pins: VOUT1, VOUT2, VTEMP,  $V_{CC}$  and POWERDOWN\_EN related to ground with specified load capacitors

### 11.2 Immunity (IEC 62132-4)

EMC tests carried out according to IEC 62132-4, under typical specification conditions at  $V_{CC} = 3.3\text{ V}$  with different constant field orientations. Pin TCC\_EN connected to  $V_{CC}$  or ground.

Direct power injection:  $150\ \Omega$ ,  $6.8\text{ nF}$ , frequency band 150 kHz to 1 GHz

Test severity limit: 12 dBm

Test ensured on pins: VOUT1, VOUT2, VTEMP,  $V_{CC}$  and POWERDOWN\_EN related to ground with specified load capacitors

The mathematically calculated mechanical angular error can be derived from measured output signals on pin VOUT1 and pin VOUT2. It will not deviate more than  $\pm 1.8$  degrees during the EMC immunity test.

The deviation of output voltage  $V_{O(VTEMP)}$  is less than  $0.009V_{CC}$  which equals with an additional error less than  $2.5\text{ }^\circ\text{C}$ .

## 12. ElectroStatic Discharge (ESD)

### 12.1 Human body model

The KMZ60 is protected against 4 kV, according to the human body model at 100 pF and 1.5 kΩ. The test is according to AEC-Q100, REV-G, method 002.

### 12.2 Machine model

The KMZ60 is protected against 400 V, according to the machine model. The test is according to AEC-Q100, REV-G, method 003.

### 12.3 Charged-device model

The KMZ60 is protected against 500 V of direct charge injection with the 4 pF verification model, according to the charged-device model. The test is according to AEC-Q100, REV-G, method 011.

### 12.4 Latch-up protection

The KMZ60 is latch-up protected against 110 mA at maximum ambient temperature. The test is according to AEC-Q100, REV-G, method 004.

## 13. Application information

The MR sensor is designed for applications with a separate Electronic Control Unit (ECU) containing an ADC with its references connected to the supply voltage. With the ADC input resolution related to  $V_{CC}$  in the same way as the MR sensor output voltage range (ratiometric), the signal dependency on supply voltage changes is minimized.

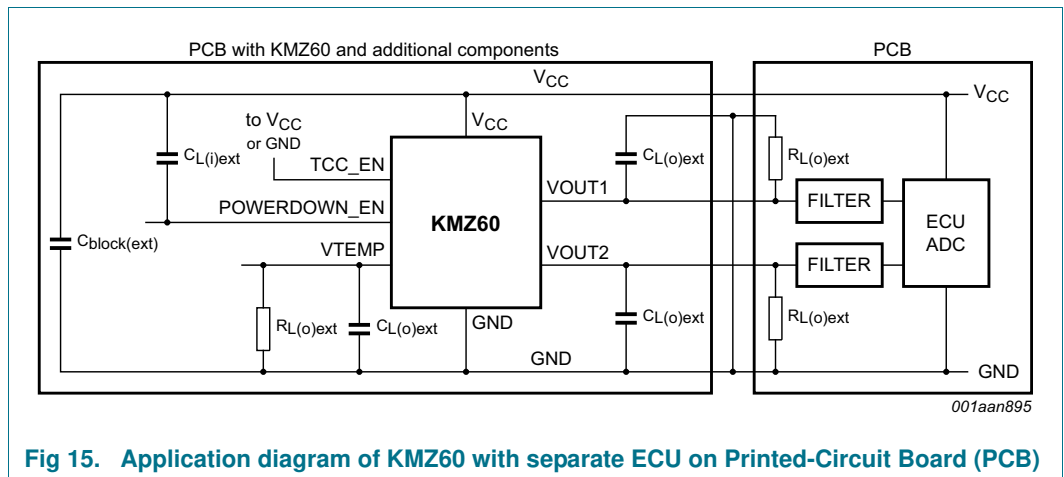

Fig 15. Application diagram of KMZ60 with separate ECU on Printed-Circuit Board (PCB)

### 13.1 Connection to ECU

Long connections on the PCB should be avoided due to the limited driving capability of both amplifier outputs. Shielding of the signal lines is recommended. The load capacitors and resistors should be matched for best angular accuracy.

In front of the ADC inputs bandwidth limitation filters should be implemented related to the used sampling frequency of the system to reduce the noise bandwidth (see [Figure 15](#)). The load resistors  $R_{L(o)ext}$  are representing the input load of the filter application and the ADC.

The ECU may be used for arctan and offset calculation, offset storage and calibration.

### 13.2 EMI

A blocking capacitor  $C_{block(ext)}$  and the load capacitors  $C_{L(o)ext}$  for the signal outputs are necessary to fulfill the EMI requirements. They should be soldered close to the related IC pins.

To protect the output stages VOUT1 and VOUT2 an internal resistance is implemented. It works like a voltage divider together with the load resistance  $R_{L(o)ext}$ .

Capacitor  $C_{L(o)ext}$  is required on pin VTEMP for output stability. The pin can be soldered directly to ground or preferably to  $V_{CC}$  on the PCB if it is not used.

Capacitor  $C_{L(i)ext}$  is required on pin POWERDOWN\_EN to fulfill the EMI demands. The pin may be soldered directly to ground on the PCB if it is not used.

### 13.3 Power consumption

The power consumption is dependent on  $V_{CC}$ , temperature, load resistance  $R_{L(o)ext}$ , load capacitance  $C_{L(o)ext}$  and frequency of the rotating magnetic field. It is recommended to refer the load resistance  $R_{L(o)ext}$  and the load capacitance  $C_{L(o)ext}$  to ground although a connection to  $V_{CC}$  is likewise possible.  $V_{O(TEMP)}$  is related to ground via the external load resistance  $R_{L(o)ext}$  on pin VTEMP.

The output voltages  $V_{o(VOUT1)}$ ,  $V_{o(VOUT2)}$  and  $V_{O(TEMP)}$  are protected against short-circuit to  $V_{CC}$  or ground by current limitation within the given time duration.

Placing the device 180 degrees rotated into the socket may lead to damages, if the supply current is not limited to 100 mA.

### 13.4 TC compensation

KMZ60 can be used as specified with TC compensation of the MR sensor signal. Pin TCC\_EN has to be connected to  $V_{CC}$ .

The pin TCC\_EN has to be connected to ground if no TC compensation is required. The output signal amplitude will decrease with increasing temperature related to the TC of the MR sensor. The angle accuracy might be slightly reduced due to the limited resolution of the used ADC.

### 13.5 Offset of signal outputs on pin VOUT1 and pin VOUT2

The single-ended output signals are referenced to  $V_{CC} / 2$  generated internally on chip. Offsets are originated from matching inaccuracies of the production process. For a good accuracy matching of the external load is additionally required.

For ESD and EMC protection the outputs are containing a series resistance. The influence of this series resistance is minimized with a large output load resistance.

### 13.6 Temperature reference output

On pin VTEMP a temperature dependent reference voltage  $V_{O(TEMP)}$  is available. This voltage is derived from an internal PTAT reference. For measurement with the proposed ADC the voltage is tracking ratiometric with  $V_{CC}$ . The reference can be used for a temperature dependent offset and angular error calibration.

The output can be left open or connected to ground or preferably to  $V_{CC}$  if not used.

### 13.7 Switching into Power-down mode

The Power-down mode can be activated by switching pin POWERDOWN\_EN to  $V_{CC}$ .

Within this mode the output pin VOUT1 and pin VOUT2 are set to high impedance to avoid current consumption across the load resistors.

Pin VTEMP will be drawn to the ground level via an internal resistance.

The Power-down mode can be entered if pin TCC\_EN is connected to  $V_{CC}$  or ground.

### 13.8 Circuit behavior in case of broken bond wires

The output voltages  $V_{o(VOUT1)}$  and  $V_{o(VOUT2)}$  will be drawn to the ground level if the implemented broken bond wire detection for all internal connections to the MR sensor is activated.

With a broken bond wire on pin TCC\_EN the pad will be drawn internally to  $V_{CC}$ . This activates the TC compensation for both signal outputs on pin VOUT1 and pin VOUT2.

A broken bond wire on pin VTEMP will interrupt the output signal on pin VTEMP.

A broken bond wire on pin POWERDOWN\_EN will disable the Power-down mode and keep the device active via an internal pull-down.

### 13.9 Signal dependence on air-gap distance

KMZ60 measures the direction of the external magnetic field within its x-y plane. The result is widely independent of the field strength as far as it is above the specified minimum value. Within a homogeneous field in x-y direction the result is independent of its placement in z direction (air-gap).

The nominal z distance of the internal x-y plane to the top surface of the plastic package is 405  $\mu\text{m}$ .

## 14. Test information

### 14.1 Quality information

This product has been qualified in accordance with the Automotive Electronics Council (AEC) standard *Q100 Rev-G - Failure mechanism based stress test qualification for integrated circuits*, and is suitable for use in automotive applications.

## 15. Package information

### 15.1 Sensor reference position

Definition of angle reference related to the edges of pin 2 and pin 7 is shown in [Figure 16](#).

Distance of sensor plane related to plastic top of the package is shown in [Figure 17](#). The nominal distance is 405  $\mu\text{m}$  (minimum 290  $\mu\text{m}$  and maximum 513  $\mu\text{m}$ ).

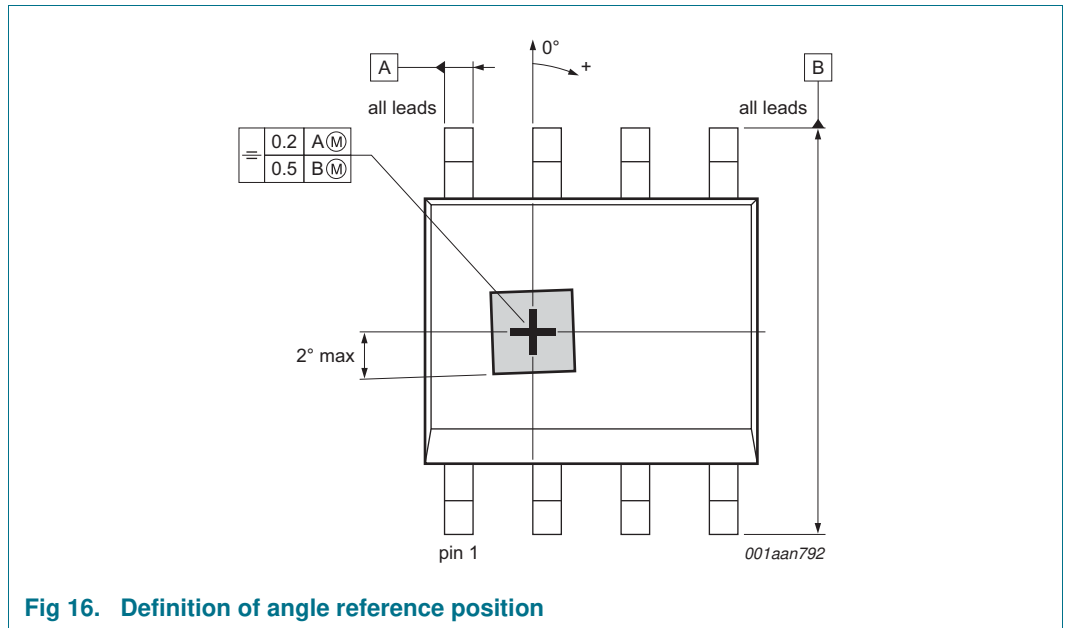

Fig 16. Definition of angle reference position

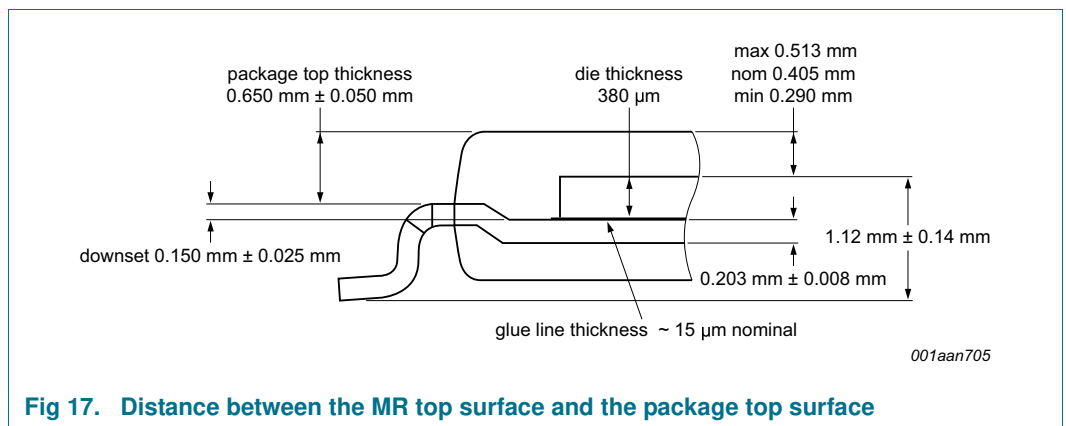

Fig 17. Distance between the MR top surface and the package top surface

Distance between MR top surface and package top surface = (package top thickness + downset) – (die thickness + glue line thickness).

### 15.2 Note

The package outline SOT96-1 (see [Figure 18](#)) allows a general wide tolerance for the lead frame thickness and the lead width. The actual reference for KMZ60 is:

$$c = 0.203 \text{ mm} \pm 0.008 \text{ mm}; b_p = 0.380 \text{ mm} \pm 0.020 \text{ mm} \text{ and } e \text{ value does not vary}$$

16. Package outline

SO8: plastic small outline package; 8 leads; body width 3.9 mm

SOT96-1

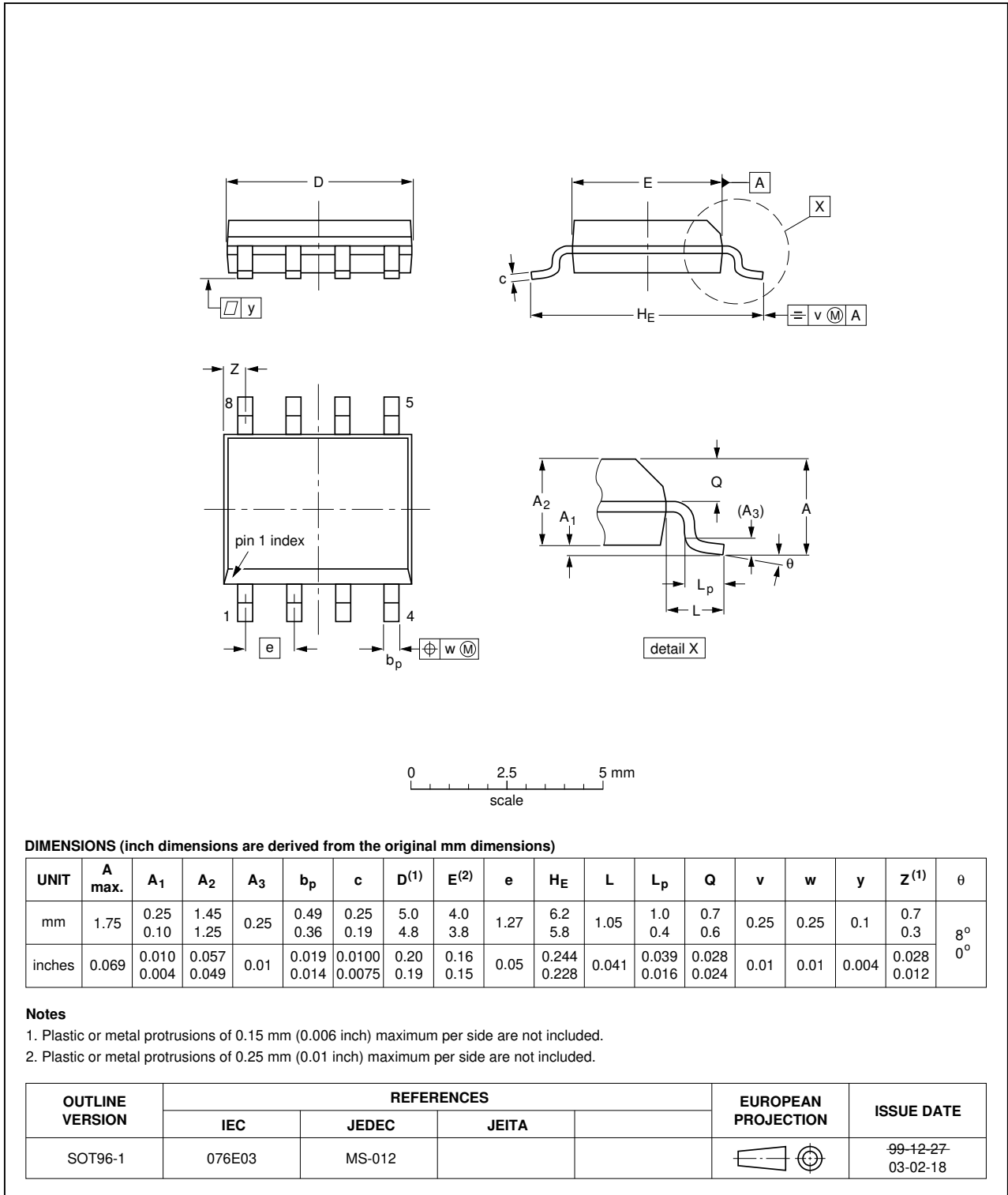

Fig 18. Package outline SOT96-1 (SO8)



## 17. Soldering of SMD packages

This text provides a very brief insight into a complex technology. A more in-depth account of soldering ICs can be found in Application Note *AN10365 "Surface mount reflow soldering description"*.

### 17.1 Introduction to soldering

Soldering is one of the most common methods through which packages are attached to Printed Circuit Boards (PCBs), to form electrical circuits. The soldered joint provides both the mechanical and the electrical connection. There is no single soldering method that is ideal for all IC packages. Wave soldering is often preferred when through-hole and Surface Mount Devices (SMDs) are mixed on one printed wiring board; however, it is not suitable for fine pitch SMDs. Reflow soldering is ideal for the small pitches and high densities that come with increased miniaturization.

### 17.2 Wave and reflow soldering

Wave soldering is a joining technology in which the joints are made by solder coming from a standing wave of liquid solder. The wave soldering process is suitable for the following:

- Through-hole components
- Leaded or leadless SMDs, which are glued to the surface of the printed circuit board

Not all SMDs can be wave soldered. Packages with solder balls, and some leadless packages which have solder lands underneath the body, cannot be wave soldered. Also, leaded SMDs with leads having a pitch smaller than ~0.6 mm cannot be wave soldered, due to an increased probability of bridging.

The reflow soldering process involves applying solder paste to a board, followed by component placement and exposure to a temperature profile. Leaded packages, packages with solder balls, and leadless packages are all reflow solderable.

Key characteristics in both wave and reflow soldering are:

- Board specifications, including the board finish, solder masks and vias
- Package footprints, including solder thieves and orientation
- The moisture sensitivity level of the packages
- Package placement
- Inspection and repair
- Lead-free soldering versus SnPb soldering

### 17.3 Wave soldering

Key characteristics in wave soldering are:

- Process issues, such as application of adhesive and flux, clinching of leads, board transport, the solder wave parameters, and the time during which components are exposed to the wave
- Solder bath specifications, including temperature and impurities

### 17.4 Reflow soldering

Key characteristics in reflow soldering are:

- Lead-free versus SnPb soldering; note that a lead-free reflow process usually leads to higher minimum peak temperatures (see [Figure 19](#)) than a SnPb process, thus reducing the process window
- Solder paste printing issues including smearing, release, and adjusting the process window for a mix of large and small components on one board
- Reflow temperature profile; this profile includes preheat, reflow (in which the board is heated to the peak temperature) and cooling down. It is imperative that the peak temperature is high enough for the solder to make reliable solder joints (a solder paste characteristic). In addition, the peak temperature must be low enough that the packages and/or boards are not damaged. The peak temperature of the package depends on package thickness and volume and is classified in accordance with [Table 8](#) and [9](#)

**Table 8. SnPb eutectic process (from J-STD-020D)**

Package thickness (mm)	Package reflow temperature (°C)	
	Volume (mm <sup>3</sup> )	
	< 350	≥ 350
< 2.5	235	220
≥ 2.5	220	220

**Table 9. Lead-free process (from J-STD-020D)**

Package thickness (mm)	Package reflow temperature (°C)		
	Volume (mm <sup>3</sup> )		
	< 350	350 to 2000	> 2000
< 1.6	260	260	260
1.6 to 2.5	260	250	245
> 2.5	250	245	245

Moisture sensitivity precautions, as indicated on the packing, must be respected at all times.

Studies have shown that small packages reach higher temperatures during reflow soldering, see [Figure 19](#).