



Chipsmall Limited consists of a professional team with an average of over 10 year of expertise in the distribution of electronic components. Based in Hongkong, we have already established firm and mutual-benefit business relationships with customers from,Europe,America and south Asia,supplying obsolete and hard-to-find components to meet their specific needs.

With the principle of “Quality Parts,Customers Priority,Honest Operation,and Considerate Service”,our business mainly focus on the distribution of electronic components. Line cards we deal with include Microchip,ALPS,ROHM,Xilinx,Pulse,ON,Everlight and Freescale. Main products comprise IC,Modules,Potentiometer,IC Socket,Relay,Connector.Our parts cover such applications as commercial,industrial, and automotives areas.

We are looking forward to setting up business relationship with you and hope to provide you with the best service and solution. Let us make a better world for our industry!



Contact us

Tel: +86-755-8981 8866 Fax: +86-755-8427 6832

Email & Skype: info@chipsmall.com Web: www.chipsmall.com

Address: A1208, Overseas Decoration Building, #122 Zhenhua RD., Futian, Shenzhen, China



PPTTEH AND PPTMT BLADE REPLACEMENT KIT INSTALLATION INSTRUCTIONS

© Panduit Corp. 2015

The KPPTTEHB and KPPTMTB Blade Replacement Kits replace the current cutter blade and cutter cap in the event of reduced performance or excessive wear caused by extended usage. The life cycle of the blade under normal operating conditions is 100,000 cycles. Follow the step-by-step instructions below:

KPPTTEHB:

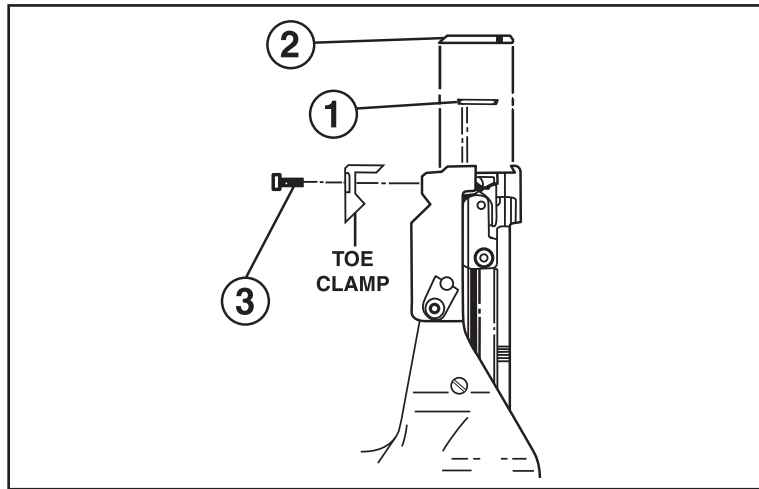

CONTENTS:

<u>ITEM</u>	<u>QTY</u>	<u>DESCRIPTION</u>	<u>PANDUIT PART NUMBER</u>
1	1	CUTTER CAP	WH14035C02
2	1	CUTTER BLADE	WH13685B02
3	2	LOW HEAD SCREWS (8-32" X 3/8")	CA12826A01
4	1	5/64" HEX WRENCH (NOT SHOWN)	CAT-12273A-PC
5	1	REMOVABLE THREADLOCKER (NOT SHOWN)	CA12493A01

REPLACING THE CUTTER BLADE: (Refer to figure above)

1. Disconnect air hose from air source and verify that tool does not actuate.
2. Hold tool with nose pointing up, and with thumb holding cutter cap in place.
3. Remove the two [2] low head screws (using 5/64" hex wrench) from under nose of tool and discard. Remove toe clamp from tool and retain. Next, carefully remove cutter cap and cutter blade from tool and discard.
4. Apply a small amount of Removable Threadlocker (included) to new low head screw threads.
5. Place new cutter blade in position and locate new cutter cap over cutter blade.
NOTE: Sharp edge of cutter blade goes toward cutter cap.
6. While holding cutter cap in place with thumb, position toe clamp over cutter cap. Fasten toe clamp using the two [2] new low head screws (with Removable Threadlocker applied) For MSDS (Material Safety Data Sheet), see www.loctite.com. Tighten screws using 5/64" hex wrench.

E-mail:
techsupport@panduit.com

EU Website:
www.panduit.com/emea

EU Email:
emeatechsupport@panduit.com

PANDUIT
www.panduit.com

Technical Support:
1-800-777-3300

Panduit Europe • EMEA Service Center
Almelo, Netherlands
Tel: +31 546 580 452 • Fax: +31 546 580 441

KPPTMTB:

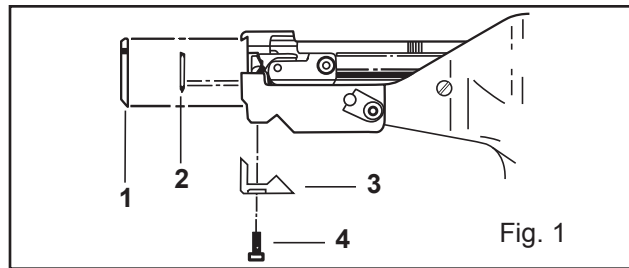

Fig. 1

ENGLISH

**KPPTMTB Blade Replacement Kit -
For replacement of a worn blade.**

1. Disconnect air hose from air source and verify that tool does not actuate.
2. Hold tool with the nose pointing up, and with thumb holding cutter cap (1) in place. Remove the two [2] low head screws (4) (using 5/64" hex wrench) from under nose of tool, and discard. Remove toe clamp (3) from tool and retain. Next, carefully remove cutter cap (1) and cutter blade (2) from tool and discard.
3. Apply a small amount of Removable Threadlocker (included) to new low head screw threads. For MSDS (Material Safety Data Sheet), see www.loctite.com. Place new cutter blade in position and locate new cutter cap over cutter blade. **NOTE:** Sharp edge of cutter blade goes toward cutter cap. While holding cutter cap in place with thumb, position toe clamp over cutter cap. Fasten toe clamp using the two [2] new low head screws (with Removable Threadlocker applied). Tighten screws using 5/64" hex wrench.

DEUTSCH

**Messer-Set KPPTMTB
(zum Austauschen des beschädigten Messers)**

1. Die Druckluftleitung von der PPTMT abkuppeln und die PPTMT wie abgebildet, halten.
2. Mit Inbusschlüssel Gr. 5/64 Zoll die beiden Schrauben (4) entfernen, dann den Messerschildhalter (3), das Messerschild (1) und das beschädigte Messer (2) abnehmen.
3. Das neue Messer (2) einsetzen und anschließend das Messerschild (1) aufsetzen. Beachten Sie, dass die Schneidkante des Messers nach oben gerichtet sein muss.
4. An die neuen Schrauben (4) einige Tropfen Schraubensicherung (mittelstark) hinzufügen und den Messerschildhalter (3) anschrauben. Für MSDS (Materialsicherheitsdaten), siehe www.loctite.com.

FRANÇAIS

**Kit de réparation du couteau KPPTMTB
(échange du couteau détérioré)**

1. Débrancher le flexible d'alimentation d'air comprimé du PPTMT et tenir le PPTMT comme indiqué.
2. Enlever les deux vis (4) à l'aide d'une clé à six pans 5/64 pouces, puis retirer le support de protège-lame (3), le protège-lame (1) et le couteau endommagé (2).
3. Positionner le nouveau couteau (2) et remettre ensuite le protège-lame (1). Veillez à ce que le tranchant du couteau soit dirigé vers le haut.
4. Déposer quelques gouttes de frein de vis (force moyenne) sur les nouvelles vis (4) et revisser le support de protège-lame (3). Pour MSDS (Fiche de sécurité Nom), voir www.loctite.com.

ITALIANO

**Kit lama KPPTMTB
(per la sostituzione di lama danneggiate)**

1. Scollegare il tubo dell'aria compressa dalla PPTMT e tenere la PPTMT come illustrato.
2. Usando una chiave per brugole di 5/64 pollici, rimuovere le due viti (4) e smontare poi il supporto della protezione lama (3), la protezione lama (1) e la lama danneggiata (2).
3. Inserire la nuova lama e rimontare la protezione lama (1). Assicurarsi che la parte tagliente della lama sia rivolta in alto.
4. Applicare alcune gocce di frenafili (di media resistenza) sulle viti nuove (4) ed avvitare il supporto della protezione lama (3). Per MSDS (Scheda tecnica Materiale sicurezza), vedi www.loctite.com.

ESPAÑOL

**Set de cuchilla KPPTMTB
(para cambiar la cuchilla deteriorada)**

1. Desacoplar el conducto de aire comprimido de la herramienta PPTMT y sujetar la herramienta PPTMT tal y como muestra la figura.
2. Soltar los dos tornillos (4) por medio de la llave de macho hexagonal tamaño 5/64 pulgadas, a continuación quitar el soporte de placa de cuchilla (3), la placa de cuchilla (1) y la cuchilla deteriorada (2).
3. Colocar la cuchilla nueva (2) y a continuación colocar la placa de cuchilla (1). Tenga en cuenta que el filo de corte de la cuchilla debe estar dirigido hacia arriba.
4. Aplicar algunas gotas de seguro de tornillo (semifuerte) en los tornillos nuevos (4) y atornillar el soporte de placa de cuchilla (3). Para MSDS (Material de Seguridad de Datos), ver www.loctite.com.