



Chipsmall Limited consists of a professional team with an average of over 10 year of expertise in the distribution of electronic components. Based in Hongkong, we have already established firm and mutual-benefit business relationships with customers from,Europe,America and south Asia,supplying obsolete and hard-to-find components to meet their specific needs.

With the principle of "Quality Parts,Customers Priority,Honest Operation,and Considerate Service",our business mainly focus on the distribution of electronic components. Line cards we deal with include Microchip,ALPS,ROHM,Xilinx,Pulse,ON,Everlight and Freescale. Main products comprise IC,Modules,Potentiometer,IC Socket,Relay,Connector.Our parts cover such applications as commercial,industrial, and automotives areas.

We are looking forward to setting up business relationship with you and hope to provide you with the best service and solution. Let us make a better world for our industry!



Contact us

Tel: +86-755-8981 8866 Fax: +86-755-8427 6832

Email & Skype: info@chipsmall.com Web: www.chipsmall.com

Address: A1208, Overseas Decoration Building, #122 Zhenhua RD., Futian, Shenzhen, China



KRPS SERIES



Description

The KRPS Series is a factory programmed time delay relay available with 1 of 15 functions and measures only 2 inches square. The KRPS offers a wide range of fixed, onboard, or externally adjustable time delays. The output relay contacts offer a full 10A rating with complete isolation. Its microcontroller timing circuit provides excellent repeat accuracy and stability. Encapsulation protects against shock, vibration, and humidity. The KRPS Series is a cost effective approach for OEM applications that require small size, isolation, accuracy, and long life. Special time ranges and functions are available.

Wiring Diagram

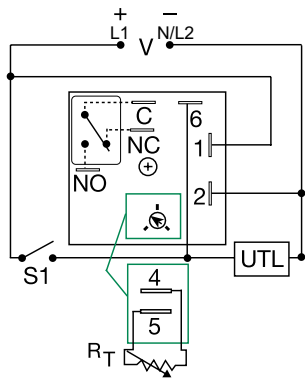

V = Voltage
C = Common, Transfer Contact
NC = Normally Closed
NO = Normally Open
S1 = Initiate Switch
UTL = Untimed Load

A knob is supplied for adjustable units, or RT terminals 4 & 5 for external adjust. See external adjustment vs. time delay chart. The untimed load is optional. S1 is not used for some functions.

Features & Benefits

FEATURES	BENEFITS
Microcontroller based	Repeat Accuracy + / - 0.5%
Compact design	Allows flexibility for OEM applications
Isolated, SPDT, 10A output	Allows control of loads for AC or DC voltages
Encapsulated	Encapsulated to protect against shock, vibration, and humidity

Accessories

P1004-95, P1004-95-X Versa-Pot
Panel mountable, industrial potentiometer recommended for remote time delay adjustment.

P0700-7 Versa-Knob
Designed for 0.25 in. (6.35 mm) shaft of Versa-Pot. Semi-gloss industrial black finish.

P1015-64 (AWG 14/16) Female Quick Connect
These 0.25 in. (6.35 mm) female terminals are constructed with an insulator barrel to provide strain relief.

P1015-18 Quick Connect to Screw Adapter
Screw adapter terminal designed for use with all modules with 0.25 in. (6.35 mm) male quick connect terminals.

C103PM (AL) DIN Rail
35 mm aluminum DIN rail available in a 36 in. (91.4 cm) length.

P1023-20 DIN Rail Adapter
Allows module to be mounted on a 35 mm DIN type rail with two #10 screws.

Ordering Information

MODEL	INPUT VOLTAGE	ADJUST.	TIME DELAY	FUNCTION
KRPS4160MM	120VAC	Fixed	60m	Delay-on-Make
KRPS913MB	230VAC	Fixed	3m	Delay-on-Break
KRPSA10.1SFT	24 - 240VAC/DC	Fixed	0.1s	Alternating
KRPSA21RE	24 - 240VAC/DC	Onboard	0.1 - 10s	Recycling, On Time First
KRPSA22B	24 - 240VAC/DC	Onboard	1 - 100s	Delay-on-Break
KRPSA24M	24 - 240VAC/DC	Onboard	0.1 - 10m	Delay-on-Make
KRPSD10.1SF	12 to 48VDC	Fixed	0.1s	Leading Edge Flip-Flop
KRPSD21B	12 to 48VDC	Onboard	0.1 - 10s	Delay-on-Break
KRPSD21M	12 to 48VDC	Onboard	0.1 - 10s	Delay-on-Make
KRPSD22M	12 to 48VDC	Onboard	1 - 100s	Delay-on-Make
KRPSD22S	12 to 48VDC	Onboard	1 - 100s	Single Shot
KRPSD25S	12 to 48VDC	Onboard	1 - 100m	Single Shot

If you don't find the part you need, call us for a custom product 800-843-8848

KRPS SERIES

Specifications

Time Delay

Type	Microcontroller circuitry
Range	0.1s - 1000h in 9 adjustable ranges or fixed
Repeat Accuracy	±0.5% or 20ms, whichever is greater
Tolerance (Factory Calibration)	≤ ±2%
Reset Time	≤ 150ms
Initiate Time	≤ 40ms; ≤ 750 operations per minute
Time Delay vs Temp. & Voltage	≤ ±2%

Input

Voltage	12 to 48VDC; 24 to 240VAC/DC
----------------	------------------------------

Tolerance

12 to 48VDC	-15% - 20%
--------------------	------------

24 to 240VAC/DC

AC Line Frequency/DC Ripple	50/60Hz / ≤ 10%
------------------------------------	-----------------

Power Consumption

AC	≤ 2VA; DC ≤ 2W
-----------	----------------

Output

Type	Isolated relay contacts
Form	SPDT
Rating (at 40°C)	10A resistive @ 125VAC 5A resistive @ 230VAC & 28VDC 1/4 hp @ 125VAC
Max. Switching Voltage	250VAC
Life (Operations)	Mechanical - 1×10^7 ; Electrical - 1×10^5

Protection

Circuitry	Encapsulated
Isolation Voltage	≥ 1500V RMS input to output
Insulation Resistance	≥ 100 MΩ
Polarity	DC units are reverse polarity protected

Mechanical

Mounting Dimensions	Surface mt. with one #10 (M5 x 0.8) screw H 50.8 mm (2.0"); W 50.8 mm (2.0"); D 30.7 mm (1.21") 0.25 in. (6.35 mm) male quick connects
----------------------------	--

Termination

Environmental

Operating/Storage Temperature	-40° to 60°C / -40° to 85°C
Humidity	95% relative, non-condensing
Weight	≈ 2.6 oz (74 g)

Output Current/Ambient Temperature

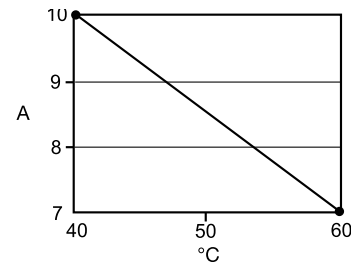

Timer Functions

Operation (Delay-on-Make)

Upon application of the input voltage, the time delay begins. The output relay is de-energized before and during the time delay. At the end of the time delay, the output energizes and remains energized until input voltage is removed.

Reset: Removing input voltage resets the time delay and output.

Operation (Delay-on-Break)

Input voltage must be applied before and during timing. Upon closure of the initiate switch, the output relay energizes. The time delay begins when the initiate switch is opened. The output remains energized during timing. At the end of the time delay, the output de-energizes. The output will energize if the initiate switch is closed when input voltage is applied.

Reset: Re-closing the initiate switch during timing resets the time delay. Removing input voltage resets the time delay and output.

Operation (Recycling)

Upon application of input voltage, the output relay energizes and the ON time begins. At the end of the ON time, the output de-energizes and the OFF time begins. At the end of the OFF time, the output energizes and the cycle repeats as long as input voltage is applied.

Reset: Removing input voltage resets the output and time delays, and returns the sequence to the first delay.

