



Chipsmall Limited consists of a professional team with an average of over 10 year of expertise in the distribution of electronic components. Based in Hongkong, we have already established firm and mutual-benefit business relationships with customers from,Europe,America and south Asia,supplying obsolete and hard-to-find components to meet their specific needs.

With the principle of “Quality Parts,Customers Priority,Honest Operation,and Considerate Service”,our business mainly focus on the distribution of electronic components. Line cards we deal with include Microchip,ALPS,ROHM,Xilinx,Pulse,ON,Everlight and Freescale. Main products comprise IC,Modules,Potentiometer,IC Socket,Relay,Connector.Our parts cover such applications as commercial,industrial, and automotives areas.

We are looking forward to setting up business relationship with you and hope to provide you with the best service and solution. Let us make a better world for our industry!



Contact us

Tel: +86-755-8981 8866 Fax: +86-755-8427 6832

Email & Skype: info@chipsmall.com Web: www.chipsmall.com

Address: A1208, Overseas Decoration Building, #122 Zhenhua RD., Futian, Shenzhen, China





KS8695PX

Integrated Multi-Port PCI Gateway Solution

Rev. 1.3

General Description

The CENTAUR KS8695PX, Multi-Port PCI Gateway Solution, delivers a new level of networking integration, performance, and overall BOM cost savings, enabling original equipment manufacturers (OEMs) to provide customers with feature-rich, low-cost solutions for the residential gateway and small office environment.

- Integration of a PCI arbiter supporting one external master.
 - Allows incorporation of a variety of productivity enhancing system interfaces, including the expanding 802.11 a/g/b wireless LAN.
- High-performance ARM™ CPU (ARM9) with 8KB I-cache, 8KB D-cache, and a memory management unit (MMU) for Linux and WinCE® support.

- XceleRouter™ technology to accelerate packet processing.
- Proven wire-speed switching technology that includes 802.1Q tag-based VLAN and quality of service (QoS) support.
- Five patented mixed-signal, low-powered Fast Ethernet transceivers with corresponding media access control (MAC) units.
- Advanced memory interface with programmable 8/16/32-bit data and 22-bit address bus with up to 64MB of total memory space for Flash, ROM, SRAM, SDRAM, and external peripherals.

Functional Diagram

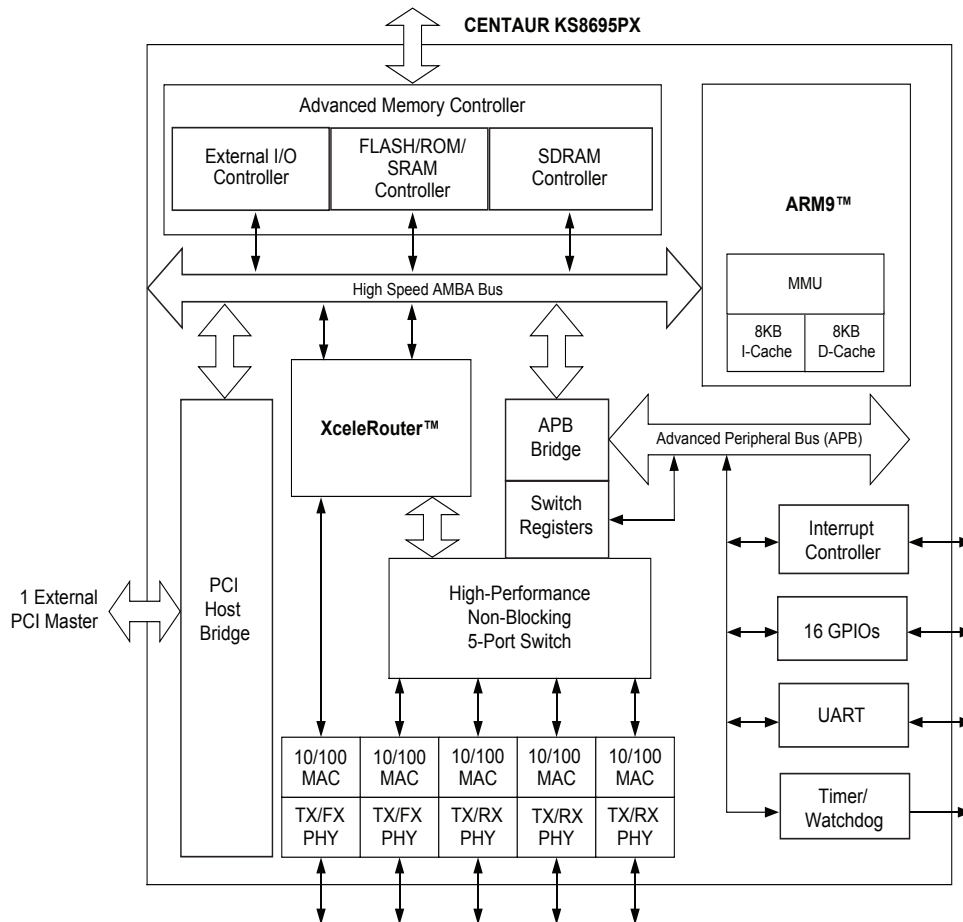

XceleRouter is a trademark of Micrel, Inc. AMD is a registered trademark of Advanced Micro Devices, Inc. ARM is a trademark of Advanced RISC Machines Ltd. Intel is a registered trademark of Intel Corporation. WinCE is a registered trademark of Microsoft Corporation.

Features

The CENTAUR KS8695PX featuring XceleRouter technology is a single-chip, multi-port PCI "gateway-on-a-chip" with all the key components integrated for a high-performance and low-cost broadband gateway

- **ARM9 High-Performance CPU Core**
 - ARM9 core at 166MHz
 - 8KB I-cache and 8KB D-cache
 - Memory management unit (MMU) for Linux and WinCE
 - 32-bit ARM and 16-bit thumb instruction sets for smaller memory footprints
- **33MHz 32-Bit PCI Interface**
 - Version PCI 2.1
 - Supports bus mastership or guest-mode
 - Supports normal and memory-mapped I/O
 - Support for miniPCI and cardbus peripherals
- **Integrated Ethernet Transceivers and Switch Engine**
 - Five 10/100 Ethernet transceivers and five MACs (1P for WAN interface, 4P for LAN switching)
 - 100BASE-FX mode option on the WAN port and one LAN port
 - Automatic MDI/MDI-X crossover on all ports
 - Wire-speed, non-blocking switch
 - 802.1Q tag-based VLAN (16 VLANs, full range VID)
 - Port-based VLAN
 - QoS/CoS packet prioritization support: per port, 802.1p, and DiffServ-based
 - 64KB on-chip frame buffer SRAM
 - VLAN ID and 802.1P tag/untag option per port
 - 802.1D Spanning Tree Protocol support
 - Programmable rate-limiting per port: 0Mbps to 100Mbps, ingress and egress, rate options for high and low priority
 - Extensive MIB counter management support
 - IGMP snooping for multicast packet filtering
 - Dedicated 1K entry look-up engine
 - Port mirroring/monitoring/sniffing
 - Broadcast and multicast storm protection with % control global and per port basis
 - Full- and half-duplex flow control
- **XceleRouter Technology**
 - TCP/UDP/IP packet header checksum generation to offload CPU tasks
 - IPv4 packet filtering on checksum errors
 - Automatic error packet discard
 - DMA engine with burst-mode support for efficient WAN/LAN data transfers
 - FIFOs for back-to-back packet transfers

- **Memory and External I/O Interfaces**
 - 8/16/32-bit wide shared data path for Flash, ROM, SRAM, SDRAM, and external I/O
 - Total memory space up to 64MB
 - Intel®/AMD®-type Flash support
- **Peripheral Support**
 - 8/16/32-bit external I/O interface supporting PCMCIA or generic CPU/DSP host I/F
 - Sixteen general purpose input/output (GPIO)
 - Two 32-bit timer counters (one watchdog)
 - Interrupt controller
- **System Design**
 - Up to 166MHz CPU and 125MHz bus speed
 - 289 PBGA package (19mm x 19mm) saving board real estate
 - Two power supplies: 1.8V core and Ethernet RX supply, 3.3V I/O and Ethernet TX supply
 - Built-in LED controls
- **Debugging**
 - ARM9 JTAG debug interface
 - UART for console port or modem back-up
- **Power Management**
 - CPU and system clock speed step-down options
 - Low-power Ethernet transceivers
 - Per port power-down and Ethernet transmit disable
- **Reference Hardware and Software Evaluation Kit**
 - Hardware evaluation board (passes class B EMI)
 - Board support package including firmware source codes, Linux kernel, and software stacks
 - Complete hardware and software reference designs available

Applications

- Multi-port wireless VoIP gateway
- Wireless mesh network node
- RG + combo 802.11 a/b/g/n access point
- Multimedia gateway
- Digital audio access point
- Network storage element
- Multi-port broadband gateway
- Multi-port firewall and VPN appliances
- Combination wireless and wireline gateway
- Fiber-to-the-home managed CPE

Ordering Information

Part Number			Temperature Range	Package
Industrial	Standard	Pb (lead)-Free		
—	KS8695PX	KSZ8695PX	0°C to +70°C	289-Pin PBGA

Revision History

Revision	Date	Summary of Changes
1.0	05/13/03	Created.
1.1	07/06/04	Copied to Micrel format and updated System Clock.
1.2	1/19/05	Insert recommended reset circuit.
1.3	9/13/05	Added Pb-Free specification. Edits to Pin Description Table.

Contents

System Level Applications	5
Pin Description	6
Pin Configuration	14
Functional Description	15
Introduction	15
CPU Features	15
PCI to AHB Bridge Features	15
Switch Engine	15
Advanced Memory Controller Features	16
Direct Memory Access (DMA) Engines.....	16
Protocol Engine and XceleRouter™ Technology	16
Network Interface.....	16
Peripherals.....	16
Other Features.....	16
Signal Description	17
System Level Hardware Interfaces	17
Configuration Pins.....	17
Reset.....	17
System Clock.....	18
Memory Interface.....	19
Signal Descriptions by Group	21
Address Map and Register Description	31
Memory Map.....	31
Memory Map Example	31
Register Description.....	31
Absolute Maximum Ratings	32
Operating Ratings	32
Electrical Characteristics	32
Timing Diagrams	34
Package Information	38

System Level Applications

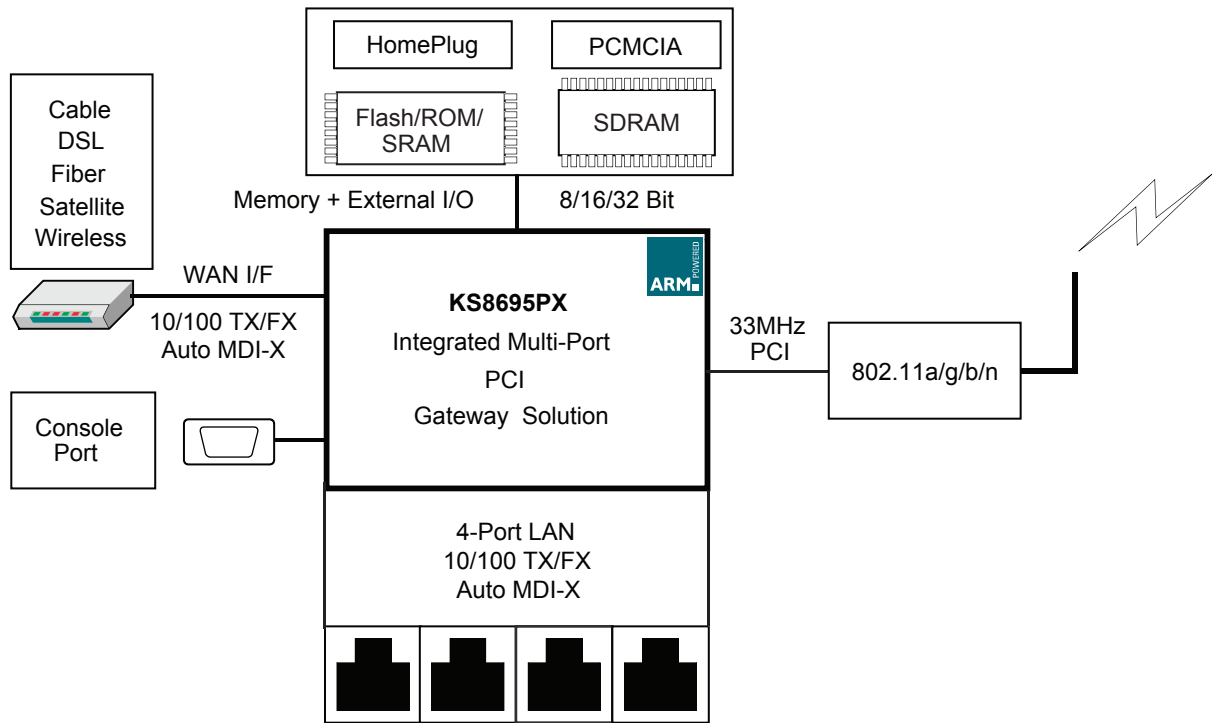

Figure 1. KS8695PX PCI Gateway System Options

Pin Description**Signal List Alphabetized by Name**

Pin Number	Pin Name	Type ⁽¹⁾	Pin Function
U4	ADDR0	O	Address Bit.
T4	ADDR1	O	Address Bit.
R3	ADDR10	O	Address Bit.
P1	ADDR11	O	Address Bit.
P2	ADDR12	O	Address Bit.
N1	ADDR13	O	Address Bit.
N2	ADDR14	O	Address Bit.
N3	ADDR15	O	Address Bit.
N4	ADDR16	O	Address Bit.
M1	ADDR17	O	Address Bit.
M2	ADDR18	O	Address Bit.
M3	ADDR19	O	Address Bit.
U3	ADDR2	O	Address Bit
P3	ADDR20/BA0	O	Address Bit/Bank Address Bit 0 for SDRAM Interface.
P4	ADDR2/BA1	O	Address Bit/Bank Address Bit 1 for SDRAM Interface.
T3	ADDR3	O	Address Bit.
U2	ADDR4	O	Address Bit.
U1	ADDR5	O	Address Bit.
T1	ADDR6	O	Address Bit.
T2	ADDR7	O	Address Bit.
R1	ADDR8	O	Address Bit.
R2	ADDR9	O	Address Bit.
E3	AGND	Gnd	Analog Signal Ground.
H7	AGND	Gnd	Analog Signal Ground.
J7	AGND	Gnd	Analog Signal Ground.
K7	AGND	Gnd	Analog Signal Ground.
L7	AGND	Gnd	Analog Signal Ground.
D14	CBEN0	I/O	PCI Commands and Byte Enable 0. Active Low.
A11	CBEN1	I/O	PCI Commands and Byte Enable 1. Active Low.
B9	CBEN2	I/O	PCI Commands and Byte Enable 2. Active Low.
A6	CBEN3	I/O	PCI Commands and Byte Enable 3. Active Low.
B10	CLKRUNN	I/O	Cardbus Clock Run Request Signal. Active Low.
U15	DATA0	I/O	External Data Bit.
T15	DATA1	I/O	External Data Bit.
U12	DATA10	I/O	External Data Bit.
T12	DATA11	I/O	External Data Bit.

Note:

1. Gnd = Ground.

O = Output.

I/O = Bidirectional.

Pin Number	Pin Name	Type ⁽¹⁾	Pin Function
R12	DATA12	I/O	External Data Bit.
P12	DATA13	I/O	External Data Bit.
U11	DATA14	I/O	External Data Bit.
T11	DATA15	I/O	External Data Bit.
R11	DATA16	I/O	External Data Bit.
P11	DATA17	I/O	External Data Bit.
U10	DATA18	I/O	External Data Bit.
T10	DATA19	I/O	External Data Bit.
U14	DATA2	I/O	External Data Bit.
R10	DATA20	I/O	External Data Bit.
P10	DATA21	I/O	External Data Bit.
U9	DATA22	I/O	External Data Bit.
T9	DATA23	I/O	External Data Bit.
R9	DATA24	I/O	External Data Bit.
P9	DATA25	I/O	External Data Bit.
U8	DATA26	I/O	External Data Bit.
T8	DATA27	I/O	External Data Bit.
R8	DATA28	I/O	External Data Bit.
P8	DATA29	I/O	External Data Bit.
T14	DATA3	I/O	External Data Bit.
R7	DATA30	I/O	External Data Bit.
P7	DATA31	I/O	External Data Bit.
R14	DATA4	I/O	External Data Bit.
P14	DATA5	I/O	External Data Bit.
U13	DATA6	I/O	External Data Bit.
T13	DATA7	I/O	External Data Bit.
R13	DATA8	I/O	External Data Bit.
P13	DATA9	I/O	External Data Bit.
C11	DEVSELN	I/O	PCI Device Select Signal. Active Low.
R16	ECSN0	O	External I/O Device Chip Select. Active Low.
T16	ECSN1	O	External I/O Device Chip Select. Active Low.
U16	ECSN2	O	External I/O Device Chip Select. Active Low.
T17	EROEN/ WRSTPLS	O/I	ROM/SRAM/FLASH and External I/O Output Enable. Active Low. WRSTO Polarity Select. WRSTPLS = 0, WRSTO = Active High; WRSTPLS = 1, Active Low.
M17	ERWEN0/ TESTACK	O	External I/O and ROM/SRAM/FLASH Write Byte Enable. Active Low.
N17	ERWEN1/ TESTREQB	O	External I/O and ROM/SRAM/FLASH Write Byte Enable. Active Low.
P17	ERWEN2/ TESTREQA	O	External I/O and ROM/SRAM/FLASH Write Byte Enable. Active Low.

Note:

1. O = Output.

I/O = Bidirectional.

O/I = Output in normal mode; input pin during reset.

Pin Number	Pin Name	Type ⁽¹⁾	Pin Function
R17	ERWEN3/ TICTESTENN	O	External I/O and ROM/SRAM/FLASH Write Byte Enable. Active Low.
P16	EWAITN	I	External Wait. Active Low.
D10	FRAMEN	I/O	PCI Bus Frame Signal. Active Low.
A1	GND	Gnd	Signal Ground.
G7	GND	Gnd	Signal Ground.
G8	GND	Gnd	Signal Ground.
G9	GND	Gnd	Signal Ground.
G10	GND	Gnd	Signal Ground.
G11	GND	Gnd	Signal Ground.
H8	GND	Gnd	Signal Ground.
H9	GND	Gnd	Signal Ground.
H10	GND	Gnd	Signal Ground.
H11	GND	Gnd	Signal Ground.
J8	GND	Gnd	Signal Ground.
J9	GND	Gnd	Signal Ground.
J10	GND	Gnd	Signal Ground.
J11	GND	Gnd	Signal Ground.
K8	GND	Gnd	Signal Ground.
K9	GND	Gnd	Signal Ground.
K10	GND	Gnd	Signal Ground.
K11	GND	Gnd	Signal Ground.
L8	GND	Gnd	Signal Ground.
L9	GND	Gnd	Signal Ground.
L10	GND	Gnd	Signal Ground.
L11	GND	Gnd	Signal Ground.
C4	GNT1N	O	PCI Bus Grant 1. Active Low. Output for Host Bridge Mode and Guest Bridge Mode.
C3	NC	—	No Connect
C2	NC	—	No Connect
G17	GPIO0/EINT0	I/O	General Purpose I/O Pin. External Interrupt Request Pin.
G16	GPIO1/EINT1	I/O	General Purpose I/O Pin. External Interrupt Request Pin.
K17	GPIO10	I/O	General Purpose I/O Pin.
K16	GPIO11	I/O	General Purpose I/O Pin.
K15	GPIO12	I/O	General Purpose I/O Pin.
K14	GPIO13	I/O	General Purpose I/O Pin.
L17	GPIO14	I/O	General Purpose I/O Pin.

Note:

1. Gnd = Ground.

I = Input.

O = Output.

I/O = Bidirectional.

Pin Number	Pin Name	Type ⁽¹⁾	Pin Function
L16	GPIO15	I/O	General Purpose I/O Pin.
H17	GPIO2/EINT2	I/O	General Purpose I/O Pin. External Interrupt Request Pin.
H16	GPIO3/EINT3	I/O	General Purpose I/O Pin. External Interrupt Request Pin.
H15	GPIO4/TOUT0	I/O	General Purpose I/O Pin. Timer 0 Output Pin.
H14	GPIO5/TOUT1	I/O	General Purpose I/O Pin. Timer 1 Output Pin.
J17	GPIO6	I/O	General Purpose I/O Pin.
J16	GPIO7	I/O	General Purpose I/O Pin.
J15	GPIO8	I/O	General Purpose I/O Pin.
J14	GPIO9	I/O	General Purpose I/O Pin.
D7	IDSEL	I	Initialization Device Select. Active High.
A9	IRDYN	I/O	PCI Initiator Ready Signal. Active Low.
F1	ISET	I	Set PHY Transmit Output Current. Connect to Ground with 3.01k Ω 1% Resistor.
B17	L1LED0	O	LAN Port 1 LED Programmable Indicator 0. Active Low.
B16	L1LED1	O	LAN Port 1 LED Programmable Indicator 1. Active Low.
C17	L2LED0	O	LAN Port 2 LED Programmable Indicator 0. Active Low.
C16	L2LED1	O	LAN Port 2 LED Programmable Indicator 1. Active Low.
D17	L3LED0	O	LAN Port 3 LED Programmable Indicator 0. Active Low.
D16	L3LED1	O	LAN Port 3 LED Programmable Indicator 1. Active Low.
E17	L4LED0	O	LAN Port 4 LED Programmable Indicator 0. Active Low.
E16	L4LED1	O	LAN Port 4 LED Programmable Indicator 1. Active Low.
H4	LANRXM1	I	LAN Port 1 PHY Receive Signal – (differential).
J4	LANRXM2	I	LAN Port 2 PHY Receive Signal – (differential).
K4	LANRXM3	I	LAN Port 3 PHY Receive Signal – (differential).
L4	LANRXM4	I	LAN Port 4 PHY Receive Signal – (differential).
H3	LANRXP1	I	LAN Port 1 PHY Receive Signal + (differential).
J3	LANRXP2	I	LAN Port 2 PHY Receive Signal + (differential).
K3	LANRXP3	I	LAN Port 3 PHY Receive Signal + (differential).
L3	LANRXP4	I	LAN Port 4 PHY Receive Signal + (differential).
H2	LANTXM1	O	LAN Port 1 PHY Transmit Signal – (differential).
J2	LANTXM2	O	LAN Port 2 PHY Transmit Signal – (differential).
K2	LANTXM3	O	LAN Port 3 PHY Transmit Signal – (differential).
L2	LANTXM4	O	LAN Port 4 PHY Transmit Signal – (differential).
H1	LANTXP1	O	LAN Port 1 PHY Transmit Signal + (differential).
J1	LANTXP2	O	LAN Port 2 PHY Transmit Signal + (differential).
K1	LANTXP3	O	LAN Port 3 PHY Transmit Signal + (differential).
L1	LANTXP4	O	LAN Port 4 PHY Transmit Signal + (differential).
E4	M66EN	I	PCI 66 MHz Enable.
D2	MPCIACTN	O	MiniPCI Active Signal. Active Low.
A16	PAD0	I/O	PCI Address and Data 0.

Note:

1. I = Input.

O = Output.

I/O = Bidirectional.

Pin Number	Pin Name	Type ⁽¹⁾	Pin Function
A15	PAD1	I/O	PCI Address and Data 1.
B13	PAD10	I/O	PCI Address and Data 10.
D13	PAD11	I/O	PCI Address and Data 11.
A12	PAD12	I/O	PCI Address and Data 12.
C12	PAD13	I/O	PCI Address and Data 13.
B12	PAD14	I/O	PCI Address and Data 14.
D12	PAD15	I/O	PCI Address and Data 15.
C9	PAD16	I/O	PCI Address and Data 16.
A8	PAD17	I/O	PCI Address and Data 17.
D9	PAD18	I/O	PCI Address and Data 18.
B8	PAD19	I/O	PCI Address and Data 19.
C15	PAD2	I/O	PCI Address and Data 2.
D8	PAD20	I/O	PCI Address and Data 20.
A7	PAD21	I/O	PCI Address and Data 21.
C7	PAD22	I/O	PCI Address and Data 22.
B7	PAD23	I/O	PCI Address and Data 23.
C6	PAD24	I/O	PCI Address and Data 24.
B6	PAD25	I/O	PCI Address and Data 25.
D6	PAD26	I/O	PCI Address and Data 26.
A5	PAD27	I/O	PCI Address and Data 27.
C5	PAD28	I/O	PCI Address and Data 28.
B5	PAD29	I/O	PCI Address and Data 29.
B15	PAD3	I/O	PCI Address and Data 3.
D5	PAD30	I/O	PCI Address and Data 30.
A4	PAD31	I/O	PCI Address and Data 31.
D15	PAD4	I/O	PCI Address and Data 4.
A14	PAD5	I/O	PCI Address and Data 5.
C14	PAD6	I/O	PCI Address and Data 6.
B14	PAD7	I/O	PCI Address and Data 7.
A13	PAD8	I/O	PCI Address and Data 8.
C13	PAD9	I/O	PCI Address and Data 9.
C8	PAR	I/O	PCI Parity.
D3	PBMS	I	PCI Bridge Mode Select. '1' = Host Bridge Mode. '0' = Guest Bridge Mode.
D4	PCLK	I	PCI Bus Clock.
A2	PCLKOUT0	O	PCI Clock Output 0.
B1	PCLKOUT1	O	PCI Clock Output 1.
C1	NC	—	No Connect
D1	NC	—	No Connect
B11	PERRN	I/O	PCI Parity Error Signal. Active Low.
A3	PRSTN	I	PCI Reset. Active Low.

Notes:

1. I = Input.
 O = Output.
 I/O = Bidirectional.

Pin Number	Pin Name	Type ⁽¹⁾	Pin Function
P15	RCSN0	O	ROM/SRAM/FLASH Chip Select. Active Low.
R15	RCSN1	O	ROM/SRAM/FLASH Chip Select. Active Low.
B4	REQ1N	I	PCI Bus Request 1. Active Low. Input for Host Bridge Mode and Guest Bridge Mode.
B3	NC	—	No Connect
B2	NC	—	No Connect
A17	RESETN	I	KS8695PX Chip Reset. Active Low.
T5	SDCASN	O	SDRAM Column Address Strobe. Active Low.
P5	SDCSN0	O	SDRAM Chip Select. Active Low Chip Select Pins for SDRAM.
R4	SDCSN1	O	SDRAM Chip Select. Active Low Chip Select Pins for SDRAM.
T7	SDICLK	I	SDRAM Clock In.
U7	SDOCLK	O	System/SDRAM Clock Out.
U6	SDQM0	O	SDRAM Data Input/Output Mask.
T6	SDQM1	O	SDRAM Data Input/Output Mask.
R6	SDQM2	O	SDRAM Data Input/Output Mask.
P6	SDQM3	O	SDRAM Data Input/Output Mask.
R5	SDRASN	O	SDRAM Row Address Strobe. Active Low.
U5	SDWEN	O	SDRAM Write Enable. Active Low.
A10	SERRN	O	PCI System Error Signal. Active Low.
D11	STOPN	I/O	PCI Stop Signal. Active Low.
G14	TCK	I	JTAG Test Clock.
F14	TDI	I	JTAG Test Data In.
F15	TDO	O	JTAG Test Data Out.
M4	TEST1	I	PHY Test Pin (factory reserved test signal).
F4	TEST2	I	PHY Test Pin (factory reserved test signal).
F17	TESTEN	I	Chip Test Enable (factory reserved test signal). Must be connected to GND for normal operation
G15	TMS	I	JTAG Test Mode Select
C10	TRDYN	I/O	PCI Target Ready Signal. Active Low.
F16	TRSTN	I	JTAG Test Reset. Active Low.
M14	UCTSN/ BISTEN	I	UART Data Set Ready. Active Low. BIST Enable (factory reserved test signal).
L15	UDCDN/ SCANEN	I	UART Data Carrier Detect. Scan Enable (factory reserved test signal).
M16	UDSRN	I	UART Data Set Ready. Active Low.
N15	UDTRN/ DBGENN	O/I	UART Data Terminal Ready. Active Low. Debug Enable (factory reserved test signal)
L14	URIN/TSTRST	I	UART Ring Indicator/Chip Test Reset (factory reserved test signal).
M15	URTSN/ CPUCLKSEL	O/I	UART Request to Send/CPU Clock Select.

Note:

1. I = Input.

O = Output.

I/O = Bidirectional.

O/I = Output in normal mode; input pin during reset.

Pin Number	Pin Name	Type ⁽¹⁾	Pin Function
N16	URXD	I	UART Receive Data.
N14	UTXD	O	UART Transmit Data.
E7	VDD1.8	P	1.8V Digital Core V _{DD} .
E8	VDD1.8	P	1.8V Digital Core V _{DD} .
E9	VDD1.8	P	1.8V Digital Core V _{DD} .
E10	VDD1.8	P	1.8V Digital Core V _{DD} .
F7	VDD1.8	P	1.8V Digital Core V _{DD} .
F8	VDD1.8	P	1.8V Digital Core V _{DD} .
F9	VDD1.8	P	1.8V Digital Core V _{DD} .
F10	VDD1.8	P	1.8V Digital Core V _{DD} .
M7	VDD1.8	P	1.8V Digital Core V _{DD} .
M8	VDD1.8	P	1.8V Digital Core V _{DD} .
M9	VDD1.8	P	1.8V Digital Core V _{DD} .
H12	VDD1.8	P	1.8V Digital Core V _{DD} .
H13	VDD1.8	P	1.8V Digital Core V _{DD} .
J12	VDD1.8	P	1.8V Digital Core V _{DD} .
J13	VDD1.8	P	1.8V Digital Core V _{DD} .
K12	VDD1.8	P	1.8V Digital Core V _{DD} .
K13	VDD1.8	P	1.8V Digital Core V _{DD} .
N7	VDD1.8	P	1.8V Digital Core V _{DD} .
N8	VDD1.8	P	1.8V Digital Core V _{DD} .
N9	VDD1.8	P	1.8V Digital Core V _{DD} .
E11	VDD3.3	P	3.3V Digital I/O Circuitry V _{DD} .
E12	VDD3.3	P	3.3V Digital I/O Circuitry V _{DD} .
E13	VDD3.3	P	3.3V Digital I/O Circuitry V _{DD} .
F11	VDD3.3	P	3.3V Digital I/O Circuitry V _{DD} .
F12	VDD3.3	P	3.3V Digital I/O Circuitry V _{DD} .
F13	VDD3.3	P	3.3V Digital I/O Circuitry V _{DD} .
G12	VDD3.3	P	3.3V Digital I/O Circuitry V _{DD} .
G13	VDD3.3	P	3.3V Digital I/O Circuitry V _{DD} .
L12	VDD3.3	P	3.3V Digital I/O Circuitry V _{DD} .
L13	VDD3.3	P	3.3V Digital I/O Circuitry V _{DD} .
M10	VDD3.3	P	3.3V Digital I/O Circuitry V _{DD} .
M11	VDD3.3	P	3.3V Digital I/O Circuitry V _{DD} .
M12	VDD3.3	P	3.3V Digital I/O Circuitry V _{DD} .
M13	VDD3.3	P	3.3V Digital I/O Circuitry V _{DD} .
N10	VDD3.3	P	3.3V digital I/O Circuitry V _{DD} .
N11	VDD3.3	P	3.3V Digital I/O Circuitry V _{DD} .
N12	VDD3.3	P	3.3V Digital I/O Circuitry V _{DD} .
N13	VDD3.3	P	3.3V Digital I/O Circuitry V _{DD} .

Notes:

1. P = Power supply.
I = Input.
O = Output.

Pin Number	Pin Name	Type ⁽¹⁾	Pin Function
E5	VDDA1.8	P	1.8V Analog V _{DD} .
E6	VDDA1.8	P	1.8V Analog V _{DD} .
F5	VDDA1.8	P	1.8V Analog V _{DD} .
F6	VDDA1.8	P	1.8V Analog V _{DD} .
G5	VDDA1.8	P	1.8V Analog V _{DD} .
G6	VDDA1.8	P	1.8V Analog V _{DD} .
H5	VDDA1.8	P	1.8V Analog V _{DD} .
H6	VDDA1.8	P	1.8V Analog V _{DD} .
J5	VDDA1.8	P	1.8V Analog V _{DD} .
J6	VDDA1.8	P	1.8V Analog V _{DD} .
K5	VDDA3.3	P	3.3V Analog V _{DD} .
K6	VDDA3.3	P	3.3V Analog V _{DD} .
L5	VDDA3.3	P	3.3V Analog V _{DD} .
L6	VDDA3.3	P	3.3V Analog V _{DD} .
M5	VDDA3.3	P	3.3V Analog V _{DD} .
M6	VDDA3.3	P	3.3V Analog V _{DD} .
N5	VDDA3.3	P	3.3V Analog V _{DD} .
N6	VDDA3.3	P	3.3V Analog V _{DD} .
F2	WANFXSD	I	WAN Fiber Signal Detect.
G4	WANRXM	I	WAN PHY Receive Signal – (differential).
G3	WANRXP	I	WAN PHY Receive Signal + (differential).
G2	WANTXM	O	WAN PHY Transmit Signal – (differential).
G1	WANTXP	O	WAN PHY Transmit Signal + (differential).
E15	WLED0/ B0SIZE0	O/I	WAN LED Programmable Indicator 0. Bank 0 Size Bit 0.
E14	WLED1/ B0SIZE1	O/I	WAN LED Programmable Indicator 1. Bank 0 Size Bit 1.
U17	WRSTO	O	Watchdog Timer Reset Output. When EROEN/WRSTPLS = 0, Active High. When EROEN/WRSTPLS = 1, Active Low.
E1	XCLK1	I	External Clock In.
E2	XCLK2	I	External Clock In (negative polarity).

Notes:

1. P = Power supply.

I = Input.

O = Output.

O/I = Output in normal mode; input pin during reset.

Pin Configuration

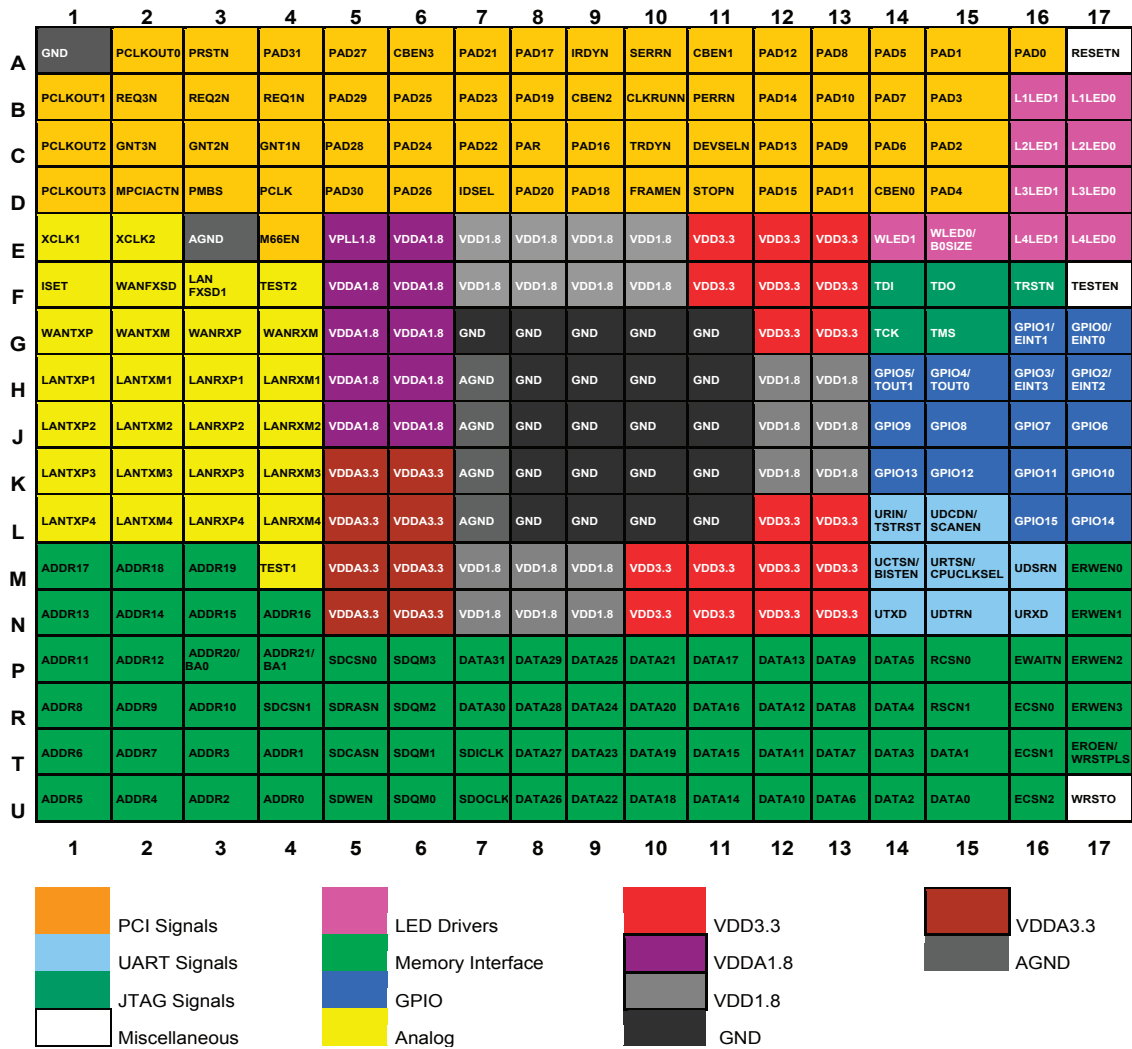

Figure 2. KS8695PX Pin Mapping (Top View)

Functional Description

Introduction

Micrel's KS8695PX, a member of the CENTAUR line of integrated processors, is a high-performance router-on-a-chip solution for Ethernet and 802.11 a/g/b based embedded systems. Designed for use in communication's routers, it integrates a PCI to AHB bridge solution for interfacing with 32-bit PCI, miniPCI, and cardbus devices. The KS8695PX combines a proven third generation 5-port managed switch, an ARM9 RISC processor with MMU, and five physical layer transceivers (PHYs) including their corresponding MAC units with Micrel's XceleRouter technology.

The KS8695PX is built around the 16/32-bit ARM9 RISC processor, which is a scalable, high-performance, microprocessor developed for highly integrated system-on-a-chip applications. It also offers a configurable 8KB I-cache and 8KB D-cache that reduces memory access latency for high-performance applications. The simple, elegant, and fully static design of the KS8695PX is especially suitable for cost-effective, power-sensitive applications.

The KS8695PX contains five 10/100 PHYs: four are for the local area network (LAN) and one is for the wide area network (WAN). Connected to the PHYs are five corresponding MAC units with an integrated Layer 2 managed switch. The combining of the switch and the analog PHYs make the KS8695PX an extremely prudent solution for SOHO router applications, saving both board space and BOM costs. The Layer 2 switch contains a 16Kx32 SRAM on-chip memory for frame buffering. The embedded frame buffer memory is designed with a 1.4Gbps on-chip memory bus. This allows the KS8695PX to perform full non-blocking frame switching and/or routing on the fly for many applications

For the media interface, the KS8695PX supports 10BASE-T and 100BASE-TX, as specified by the IEEE 802.3 standard, and 100 BASE-FX on the WAN port and on one LAN port

The KS8695PX supports two modes of operation in the PCI bus environment: host bridge mode and guest bridge mode. In the host bridge mode, the ARM9 processor acts as the host of the entire system. It configures other PCI devices and coordinates their transactions, including initiating transactions between the PCI devices and AHB bus subsystem. An on-chip PCI arbiter is included to determine the PCI bus ownership among PCI master devices. In host bridge mode, all I/O registers, including those for the embedded switch, are configured by the ARM9 processor through the on-chip AMBA bus interface.

In guest bridge mode, all of the I/O registers are programmed by either the external host CPU on the PCI bus or the local ARM9 host processor through the AMBA bus. The KS8695PX functions as a slave on the PCI bus with the on-chip PCI arbiter disabled. The KS8695PXX can be configured by either the ARM9 CPU or the PCI host CPU. In both cases, the KS8695PX memory subsystem is accessible from either the PCI host or the ARM9 CPU. Communications between the external host CPU and the ARM9 is accomplished through message passing or through shared memory.

CPU Features

- 166MHz ARM9 RISC processor core
- On-chip AMBA bus 2.0 interfaces
- 16-bit thumb programming to relax memory requirement
- 8KB I-cache and 8KB D-cache
- Little-endian mode supported
- Configurable memory management unit
- Supports reduced CPU and system clock speed for power savings

PCI to AHB Bridge Features

- Support 33MHz, 32-bit data PCI bus
- Integrated PCI bridge support for interfacing with 32-bit miniPCI or cardbus devices
- Independent AHB and PCI clock speed
- Supports 125MHz AHB speed
- Supports PCI revision 2.1 protocols
- Supports AHB bus 2.0 interfaces
- Supports both regular and memory-mapped I/O on the PCI interface
- Integrated PCI arbiter with power-on option to enable or disable
- Support Round Robin arbitration with three external PCI devices and one internal device
- Supports AHB burst transfers up to 16 data words
- Configurable PCI registers by host CPU ARM9
- Supports bus mastership from PCI to AHB or AHB to PCI bus

Switch Engine

- 5-Port 10/100 integrated switch with one WAN and four LAN physical layer transceivers
- 16Kx32 on-chip SRAM for frame buffering
- 1.4Gbps on-chip memory bandwidth for wire-speed frame switching
- 10Mbps and 100Mbps modes of operation for both full and half duplex

Switch Engine (continued)

- Supports 802.1Q tag-based VLAN and port-based VLAN
- Supports 8.2,1p-based priority, DiffServ priority, and post-based priority
- Integrated address look-up engine, supports 1K absolute MAC addresses
- Automatic address learning, address aging, and address migration
- Broadcast storm protection
- Full-duplex IEEE 802.3x flow control
- Half-duplex back pressure flow control
- Supports IGMP snooping
- Spanning Tree Protocol support

Advanced Memory Controller Features

- Supports glueless connection to two banks of ROM/SRAM/FLASH memory with programmable 8/16/32 bit data bus and programmable access timing
- Supports glueless connection to two SDRAM banks with programmable 8/16/32-bit data bus and programmable RAS/CAS latency
- Supports three external I/O banks with programmable 8/16/32-bit data bus and programmable access timing
- Programmable system clock speed for power management
- Automatic address line mapping for 8/16/32-bit accesses on Flash, ROM, SRAM, and SDRAM interfaces

Direct Memory Access (DMA) Engines

- Independent MAC DMA engine with programmable burst mode for WAN port
- Independent MAC DMA engine with programmable burst mode for LAN ports
- Supports little-endian byte ordering for memory buffers and descriptors
- Contains large independent receive and transmit FIFOs (3KB receive/3KB transmit) for back-to-back packet receive, and guaranteed no under-run packet transmit
- Data alignment logic and scatter gather capability

Protocol Engine/XceleRouter Technology

- Supports IPv4 IP header/TCP/UDP packet checksum generation for host CPU offloading
- Supports IPv4 packet filtering based on checksum errors

Network Interface

- Features five MAC units and five PHY units
- Supports 10BASE-T and 100BASE-TX on all LAN ports and one WAN port. Also supports 100BASE-FX on the WAN port and on one LAN port
- Supports automatic CRC generation and checking
- Supports automatic error packet discard
- Supports IEEE 802.3 auto-negotiation algorithm of full-duplex and half-duplex operation for 10Mbps and 100Mbps
- Supports full-/half-duplex operation on PHY interfaces
- Fully compliant with IEEE 802.3 Ethernet standards
- IEEE 802.3 full-duplex flow control and half-duplex backpressure collision flow control
- Supports MDI/MDI-X auto-crossover

Peripherals

- Twenty-eight interrupt sources, including four external interrupt sources
- Normal or fast interrupt mode (IRQ, FIQ) supported
- Prioritized interrupt handling
- Sixteen programmable general purpose I/O. Pins individually configurable to input, output, or I/O mode for dedicated signals.
- Two programmable 32-bit timers with watchdog timer capability
- High-speed UART interface up to 115kbps

Other Features

- Integrated PLL to generate CPU and system clocks
- JTAG development interface for ICE connection
- 19mm x 19mm 289-pin PBGA
- 1.8V CMOS for core and 3.3V for I/O

System Level Hardware Interfaces

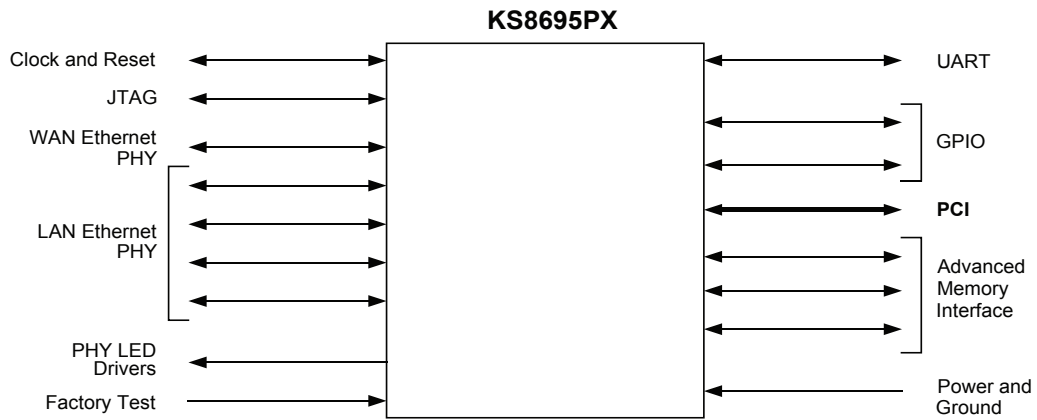

Figure 3. System Level Interfaces

At the system level the KS8695PX features the following interfaces:

- Clock interface for crystal or external oscillator
- JTAG development interface
- One WAN Ethernet physical interface
- Four LAN Ethernet physical interfaces
- PHY LED drivers
- One high-speed UART interface
- Sixteen GPIO pins
- 33MHz, 32-bit PCI interface supporting one external master
- Advanced memory interface
 - Programmable synchronous bus rate
 - Programmable asynchronous interface timing
 - Independently programmable data bus width for static and synchronous memory
 - Glueless connection to SDRAM
 - Glueless connection to flash memory or ROM
- Factory test
- Power and ground

Configuration Pins

The following pins are sampled as input during reset

Configuration	Pin Name	Pin #	Setting
Bank0 Flash Data Width	B0SIZE[1:0]	E14, E15	'00' = reserved '01' = byte wide '10' = half word wide (16 bits) '11' = word wide (32 bits)
WRSTO Polarity	EROEN/WRSTPLS	U17	'0' = active high '1' = active low
CPU Clock Select	URTSN/CPUCLKSEL	M15	'0' = normal mode (PLL) '1' = bypass internal PLL
PCI Bridge Mode	PBMS	D3	'0' = guest bridge mode '1' = host bridge mode
CPUCLKSEL	URTSN/CPUCLKSEL	M15	'0' = normal operation '1' = factory reserved
Debug Enable	UDTRN/DBGENN	N15	'0' = factory reserved

Table 1. Configuration Pins

Following pins have second function as factory test of chip

Configuration	Pin Name	Pin #	Setting
Chip Test Enable	TESTEN	F17	'0' = normal operation '1' = factory reserved. Used for factory test of chip and affects all signals listed in this table.
	ERWEN0/TESTACK	M17	
	ERWEN1/TESTREQB	N17	
	ERWEN2/TESTREQA	P17	
	ERWEN3/TICTESTTENN	R17	
	UCTSN/BISTEN	M14	
	UDCDN/SCANEN	L15	
	URIN/TSTRST	L14	
	TEST1	M4	
	TEST2	F4	

Table 2. Configuration Pins

Reset

The KS8695PX has a single reset input that can be driven by a system reset circuit or a simple power on reset circuit. The KS8695PX also features a reset output (WRSTO) that can be used to reset other devices in the system. WRSTO can be configured as either an active high reset or an active low reset through a strap-in option on pin U17, as shown in Table 1. The KS8695PX also has a built in watchdog timer. When the watchdog timer is programmed and the timer setting expires, the KS8695PX resets itself and also asserts WRSTO to reset the other devices in the system. Figure 4 shows a typical system using the KS8695PX WRSTO as the system reset.

Reset Circuit Diagram

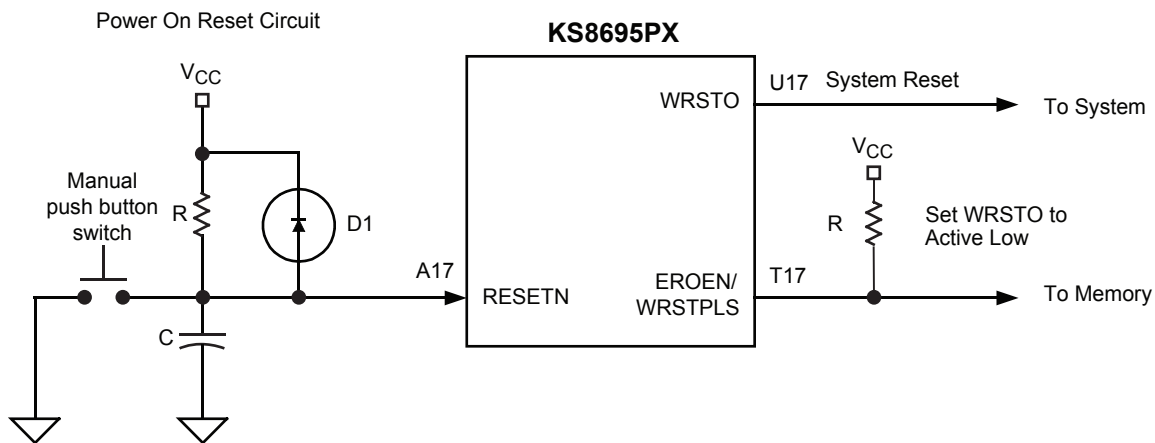

Figure 4. Example of a Reset Circuit

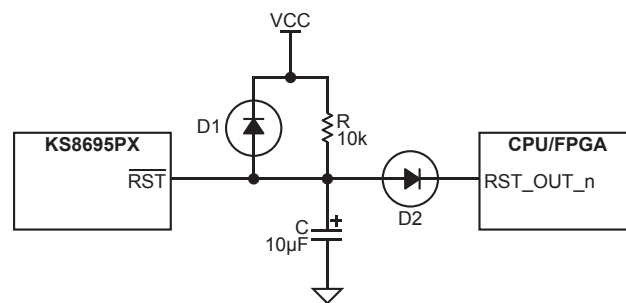

Figure 5. Recommended circuit for Interfacing with CPU/FPGA Reset

At power-on-reset, R, C, and D1 provide the necessary ramp rise time to reset the Micrel device. The reset out from CPU/FPGA provides warm reset after power up

System Clock

The clock to the KS8695PX is supplied by either a 25MHz ± 50 ppm crystal or by an oscillator. If an oscillator is used, it must be connected to the XCLK1 input (pin E1) on the KS8695PX. If a crystal is used, it must be connected with a circuit similar to the one shown below. The 25MHz input clock is used by an internal PLL to generate the programmable SDOCLK. SDOCLK is the system clock and can be programmed from 25MHz to 125MHz using the system clock and bus control register at offset 0x0004. The CPUCLKSEL strap-in option on pin M15 needs to be pulled low for normal operation. SDICLK is used to register the data read from the SDRAM back into the KS8695PX. The system designer must ensure that SDRAM timing is met when routing SDOCLK back to SDICLK.

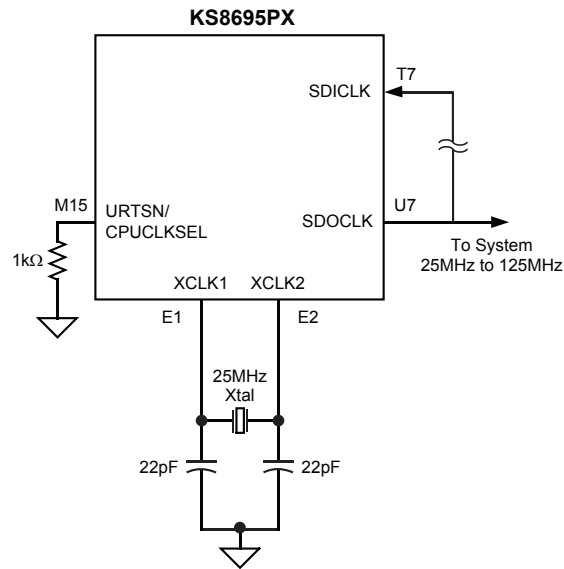

Figure 6. Typical Clock Circuit

Memory Interface

The KS8695PX has a glueless interface for SDRAM and static memory, i.e. ROM, SRAM, and Flash. It supports up to two banks of static memory (Figure 7), up to two banks of SDRAM (Figure 8), and three banks of external I/O (Figure 9). The total address space for the KS8695PX is 64MB. This includes SDRAM, static memory, external I/O, and the KS8695PX's own 64KB of register space.

The memory interface for the SDRAM and static memory has a special automatic address mapping feature. This allows the designer to connect address bit 0 on the memory to ADDR[0] on the KS8695PX and address bit 1 on the memory to ADDR[1] on the memory, regardless of whether the designer is trying to achieve word, half word, or byte addressing.

The KS8695PX memory controller performs the address mapping internally. This permits the designer to use the maximum amount of address bits, instead of losing one or two bits because of address mapping. For external I/O, however, the designer still needs to take care of the address mapping (see Figure 9).

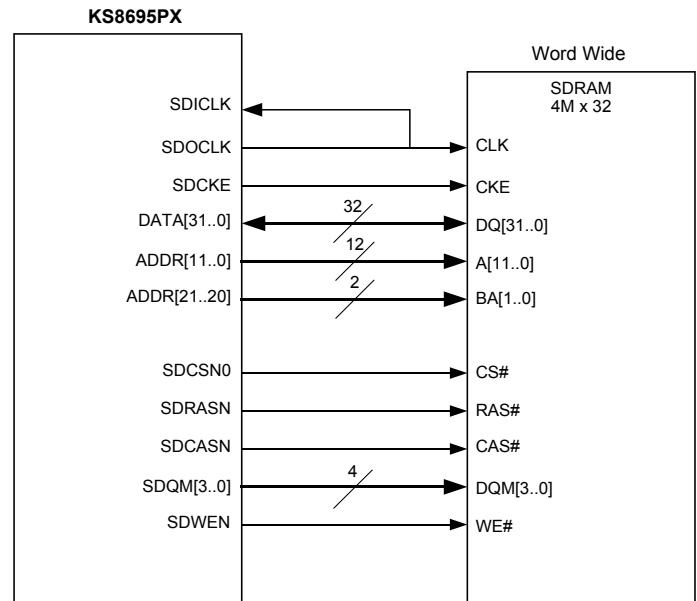
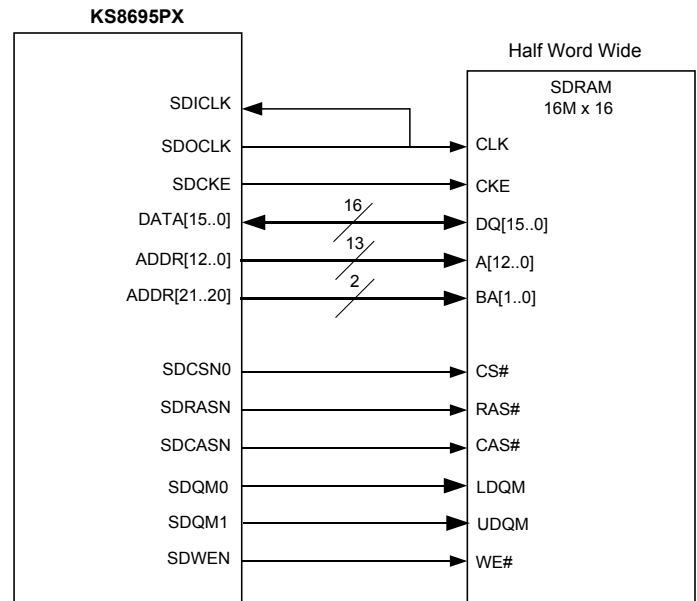

Figure 8. SDRAM Interface Examples

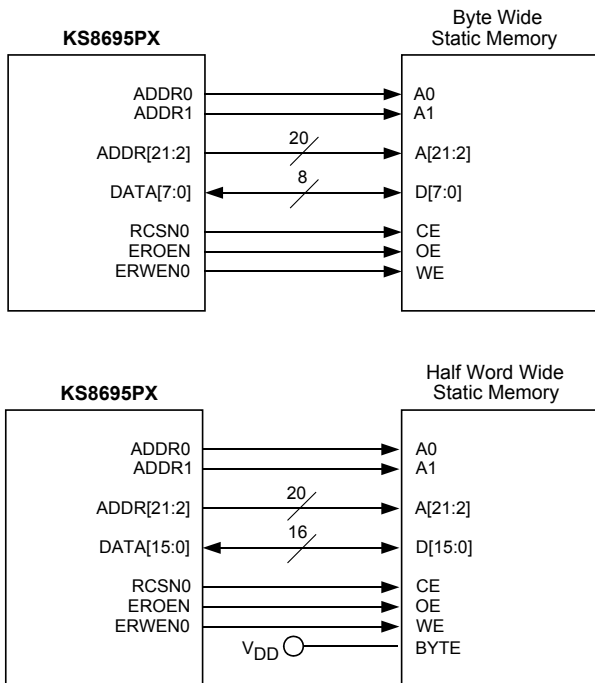

Figure 7. Static Memory Interface Examples

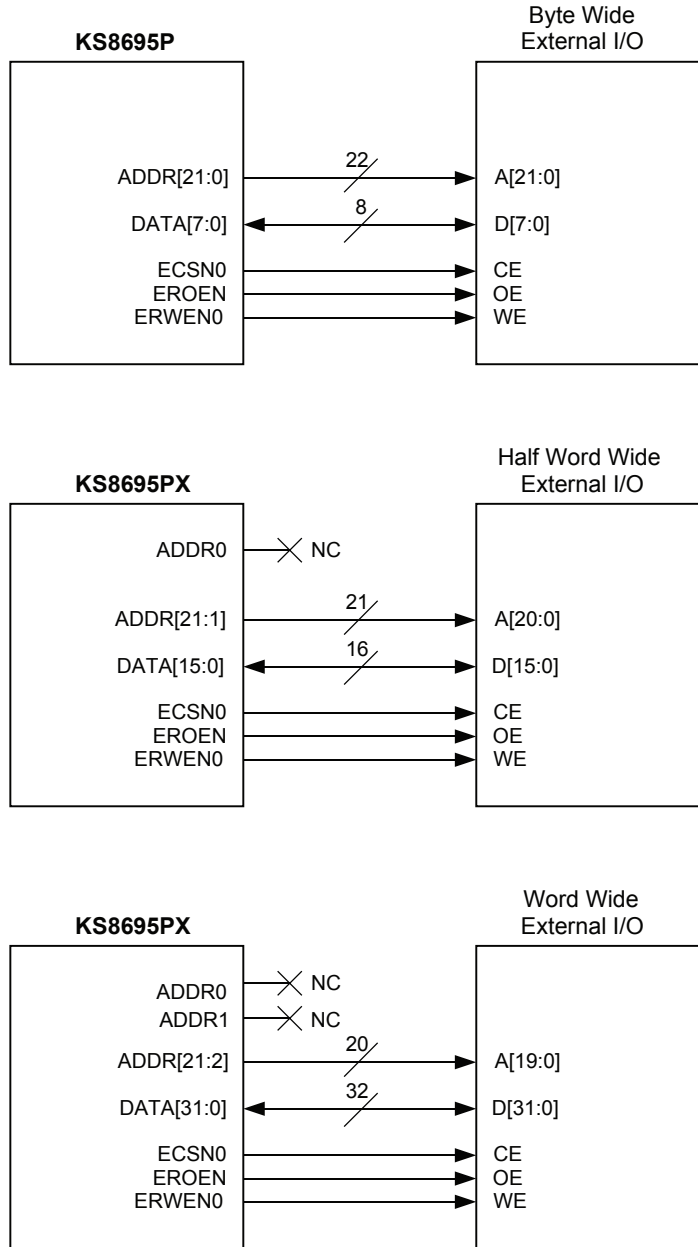

Figure 9. External I/O Interface Examples

KS8695PX outputs ERWEN[3:0] as write strobes to byte wide, half-word wide, and word-wide memory port. The following figures show the most commonly implemented examples

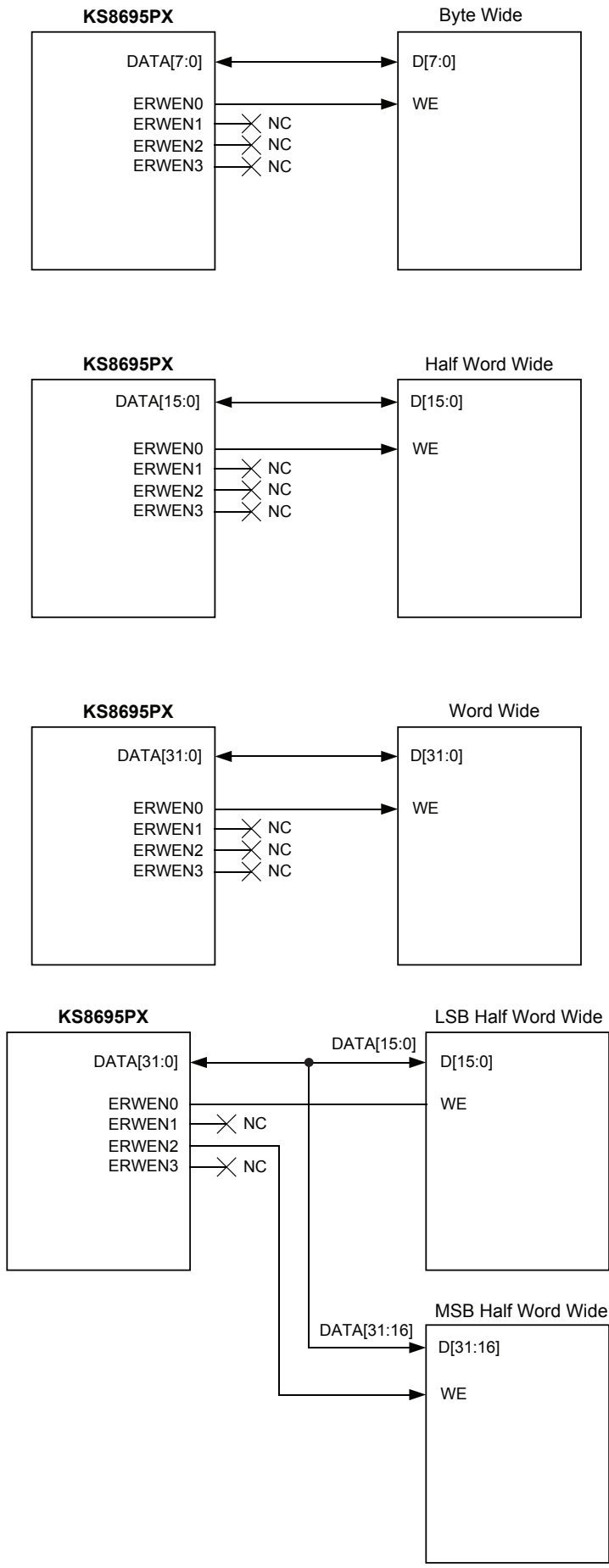

Figure 10 ERWEN[3:0] Interface Examples

Signal Descriptions by Group

Clock and Reset Pins

Pin	Name	I/O Type ⁽¹⁾	Description
E1	XCLK1/ CPUCLK	I	External Clock In. This signal is used as the source clock for the transmit clock of the internal MAC and PHY. The clock frequency is 25MHz ±50ppm. The XCLK1 signal is also used as the reference clock signal for the internal PLL to generate the 125MHz internal system clock.
E2	XCLK2	I	External Clock In. Used with XCLK1 pin when another polarity of crystal is needed. This is unused for a normal clock input.
M15	URTSN/ CPUCLKSEL	O/I	Normal Mode: UART request to send. Active low output. During reset: CPU clock select. Select CPU clock source. CPUCLKSEL=0 (normal mode), the internal PLL clock output is used as the CPU clock source. CPUCLKSEL=1 (factory reserved test signal).
A17	RESETN	I	KS8695PX chip reset. Active low input asserted for at least 256 system clock (40ns) cycles to reset the KS8695PX. When in the reset state, all the output pins are tri-stated and all open drain signals are floating.
U17	WRSTO	O	Watchdog timer reset output. This signal is asserted for at least 200ms if RESETN is asserted or when the internal watchdog timer expires.
T17	EROEN/ WRSTPLS	O/I	Normal Mode: ROM/SRAM/FLASH and External I/O output enable. Active low. When asserted, this signal controls the output enable port of the specified device. During reset: Watchdog timer reset polarity setting. WRSTPLS=0, Active high; WRSTPLS=1, Active low. No default.

JTAG Interface Pins

Pin	Name	I/O Type ⁽¹⁾	Description
G14	TCK	I	JTAG test clock.
G15	TMS	I	JTAG test mode select.
F14	TDI	I	JTAG test data in.
F15	TDO	O	JTAG test data out.
F16	TRSTN	I	JTAG test reset. Active low.

WAN Ethernet Physical Interface Pins

Pin	Name	I/O Type ⁽¹⁾	Description
G1	WANTXP	O	WAN PHY transmit signal + (differential).
G2	WANTXM	O	WAN PHY transmit signal – (differential).
G3	WANRXP	I	WAN PHY receive signal + (differential).
G4	WANRXM	I	WAN PHY receive signal – (differential).
G5	WANFXSD	I	WAN fiber signal detect. Signal detect input when the WAN port is operated in 100BASE-FX 100Mb fiber mode. See Application Note 10.

Note:

1. I = Input.

O = Output.

O/I = Output in normal mode; input pin during reset.

LAN Ethernet Physical Interface Pins

Pin	Name	I/O Type ⁽¹⁾	Description
H1 J1 K1 L1	LANTXP1 LANTXP2 LANTXP3 LANTXP4	I	LAN Port[4:1] PHY transmit signal + (differential).
H2 J2 K2 L2	LANTXM1 LANTXM2 LANTXM3 LANTXM4	I	LAN Port[4:1] PHY transmit signal – (differential).
H3 J3 K3 L3	LANRXP1 LANRXP2 LANRXP3 LANRXP4	O	LAN Port[4:1] PHY receive signal + (differential).
H4 J4 K4 L4	LANRXM1 LANRXM2 LANRXM3 LANRXM4	O	LAN Port[4:1] PHY receive signal – (differential).
F1	ISET	I	Set PHY transmit output current. Connect to ground through a 3.01k Ω 1% resistor.
F3	LANFXSD1	I	LAN fiber signal detect. Signal detect input when the LAN1 port is operated in 100BASE-FX 100Mb fiber mode. See Application Note 107.

PHY LED Drivers

Pin	Name	I/O Type ⁽¹⁾	Description
E15	WLED0/ B0SIZE0	O/I	Normal Mode: WAN LED indicator 0. Programmable via WAN misc. Control register bits [2:0]. '000' = Speed; '001' = Link; '010' = Full/half duplex; '011' = Collision; '100' = TX/RX activity; '101' = Full-duplex collision; '110' = Link/Activity. During reset: Bank 0 Data Access Size. Bank 0 is used for the boot program. B0SIZE[1:0] are used to specify the size of the bank 0 data bus width as follows: '01' = one byte, '10' = half-word, '11' = one word, and '00' = reserved.
E14	WLED1/ B0SIZE1	O/I	Normal Mode: WAN LED indicator 1. Programmable via WAN Misc. Control register bits [6:4]. '000' = Speed; '001' = Link; '010' = Full/half duplex; '011' = Collision; '100' = TX/RX activity; '101' = Full-duplex collision; '110' = Link/Activity. During reset: Bank 0 data access size. Bank 0 is used for the boot program. B0SIZE[1:0] are used to specify the size of the bank 0 data bus width as follows: '01' = one byte, '10' = half-word, '11' = one word, and '00' = reserved.
B17 C17 D17 E17	L1LED0 L2LED0 L3LED0 L4LED0	O	LAN Port[4:1] LED indicator 0. Programmable via switch control 0 register bits [27:25]. '000' = Speed; '001' = Link; '010' = Full/half duplex; '011' = Collision; '100' = TX/RX activity; '101' = Full-duplex collision; '110' = Link/Activity.
B16 C16 D16 E16	L1LED1 L2LED1 L3LED1 L4LED1	O	LAN Port[4:1] LED indicator 1. Programmable via switch control 0 register bits [24:22]. '000' = Speed; '001' = Link; '010' = Full/half duplex; '011' = Collision; '100' = TX/RX activity; '101' = Full-duplex collision; '110' = Link/Activity.

Note:

1. I = Input.

O = Output.

O/I = Output in normal mode; input pin during reset.

UART Pins

Pin	Name	I/O Type ⁽¹⁾	Description
N16	URXD	I	UART receive data.
N14	UTXD	O	UART transmit data.
N15	UDTRN/ DBGENN	O/I	UART data terminal ready. Active low. DBGENN = 0 (factory reserved test signal)
M16	UDSRN	I	UART data set ready. Active low.
M15	URTSN/ CPUCLKSEL	O/I	Normal mode: UART request to send. Active low output. During reset: CPU clock select. Select CPU clock source. CPUCLKSEL=0 (normal mode), the internal PLL clock output is used as the CPU clock source. CPUCLKSEL=1 (factory reserved test signal).
M14	UCTSN/ BISTEN	I	UART clear to send. BIST enable (factory reserved test signal).
L15	UDCDN/ SCANEN	I	UART data carrier detect. Scan enable (factory reserved test signal).
L14	URIN/ TSTRST	I	UART ring indicator. Chip test reset (factory reserved test signal).

General Purpose I/O Pins

Pin	Name	I/O Type ⁽¹⁾	Description
G17	GPIO0/ EINT0	I/O	General purpose I/O pin. External interrupt request pin.
G16	GPIO1/ EINT1	I/O	General purpose I/O pin. External interrupt request pin.
H17	GPIO2/ EINT2	I/O	General purpose I/O pin. External interrupt request pin.
H16	GPIO3/ EINT3	I/O	General purpose I/O pin. External interrupt request pin.
H15	GPIO4/ TOUT0	I/O	General purpose I/O pin. Timer 0 output pin.
H14	GPIO5/ TOUT1	I/O	General purpose I/O pin. Timer 1 output pin.
J17	GPIO6	I/O	General purpose I/O pin.
J16	GPIO7	I/O	General purpose I/O pin.
J15	GPIO8	I/O	General purpose I/O pin.
J14	GPIO9	I/O	General purpose I/O pin.
K17	GPIO10	I/O	General purpose I/O pin.
K16	GPIO11	I/O	General purpose I/O pin.
K15	GPIO12	I/O	General purpose I/O pin.
K14	GPIO13	I/O	General purpose I/O pin.
L17	GPIO14	I/O	General purpose I/O pin.
L16	GPIO15	I/O	General purpose I/O pin.
A3	PRSTN	I	PCI Reset. Active low. This signal is an input used to reset the KS8695PX PCI logic. If the KS8695PX is the host, use the RESETN signal to drive this input. If the KS8695PX is a guest, use the system reset to drive this signal.

Note:

1. I = Input.

O = Output.

I/O = Bidirectional.

O/I = Output in normal mode; input pin during reset.