



Chipsmall Limited consists of a professional team with an average of over 10 year of expertise in the distribution of electronic components. Based in Hongkong, we have already established firm and mutual-benefit business relationships with customers from,Europe,America and south Asia,supplying obsolete and hard-to-find components to meet their specific needs.

With the principle of “Quality Parts,Customers Priority,Honest Operation,and Considerate Service”,our business mainly focus on the distribution of electronic components. Line cards we deal with include Microchip,ALPS,ROHM,Xilinx,Pulse,ON,Everlight and Freescale. Main products comprise IC,Modules,Potentiometer,IC Socket,Relay,Connector.Our parts cover such applications as commercial,industrial, and automotives areas.

We are looking forward to setting up business relationship with you and hope to provide you with the best service and solution. Let us make a better world for our industry!



Contact us

Tel: +86-755-8981 8866 Fax: +86-755-8427 6832

Email & Skype: info@chipsmall.com Web: www.chipsmall.com

Address: A1208, Overseas Decoration Building, #122 Zhenhua RD., Futian, Shenzhen, China



FEATURES

- TI OMAP-L138 Dual Core Application Processor
 - **456 MHz (Max) C674x VLIW DSP**
 - Floating Point DSP
 - 32 KB L1 Program Cache
 - 32 KB L1 Data Cache
 - 256 KB L2 cache
 - 1024 KB boot ROM
 - JTAG Emulation/Debug
 - **456 MHz (Max) ARM926EJ-S MPU**
 - 16 KB L1 Program Cache
 - 16 KB L1 Data Cache
 - 8 KB Internal RAM
 - 64 KB boot ROM
 - JTAG Emulation/Debug
- On-Board Xilinx Spartan-6 FPGA
 - Up To XC6SLX45
 - Up To 2,088 KBits Block RAM
 - Up To 6,822 Slices (6 Input LUTs)
 - 1050 Mbps data rate
 - JTAG Interface/Debug
- Up To 256 MB mDDR2 CPU RAM
- Up To 512 MB Parallel NAND FLASH
- 8 MB SPI based NOR FLASH
- Integrated Power Management
- Standard SO-DIMM-200 Interface
 - 96 FPGA User I/O Pins
 - 10/100 EMAC MII / MDIO
 - 2 UARTS
 - 2 McBSPs
 - 2 USB Ports
 - Video Output
 - Camera/Video Input
 - MMC/SD
 - SATA
 - Single 3.3V Power Supply



(actual size)

APPLICATIONS

- Embedded Instrumentation
- Industrial Automation
- Industrial Instrumentation
- Medical Instrumentation
- Embedded Control Processing
- Network Enabled Data Acquisition
- Test and Measurement
- Software Defined Radio
- Bar Code Scanners
- Power Protection Systems
- Portable Data Terminals

BENEFITS

- Rapid Development / Deployment
- Multiple Connectivity and Interface Options
- Rich User Interfaces
- High System Integration
- Fixed & Floating Point Operations in Single CPU
- High Level OS Support
 - Linux
 - QNX 6.4
 - Windows Embedded CE Ready
 - ThreadX Real Time OS
- Embedded Digital Signal Processing

DESCRIPTION

The MityDSP-L138F is a highly configurable, very small form-factor processor card that features a Texas Instruments OMAP-L138 456 MHz (max) Applications Processor (OMAP) tightly integrated with the Xilinx Spartan-6 Field Programmable Gate Array (FPGA), FLASH (NAND, and NOR) and mDDR2 RAM memory subsystems. The design of the MityDSP-L138F allows end users the capability to develop programs/logic images for both the OMAP and the FPGA. The MityDSP-L138F provides a complete and flexible digital processing infrastructure necessary for the most demanding embedded applications development.

The onboard OMAP-L138 processor provides a dual CPU core topology. The OMAP-L138 includes an ARM926EJ-S micro-processor unit (MPU) capable of running the rich software applications programmer interfaces (APIs) expected by modern system designers. The ARM architecture supports several operating systems, including Linux and Windows Embedded CE. In addition to the ARM core, the OMAP-L138 also includes a TMS320C674x floating point digital signal processing (DSP) core. The DSP core supports the freely provided TI DSP/BIOS real-time kernel. Users can leverage the DSP to execute real-time compute algorithms (codecs, image/data processing, compression techniques, filtering, etc.)

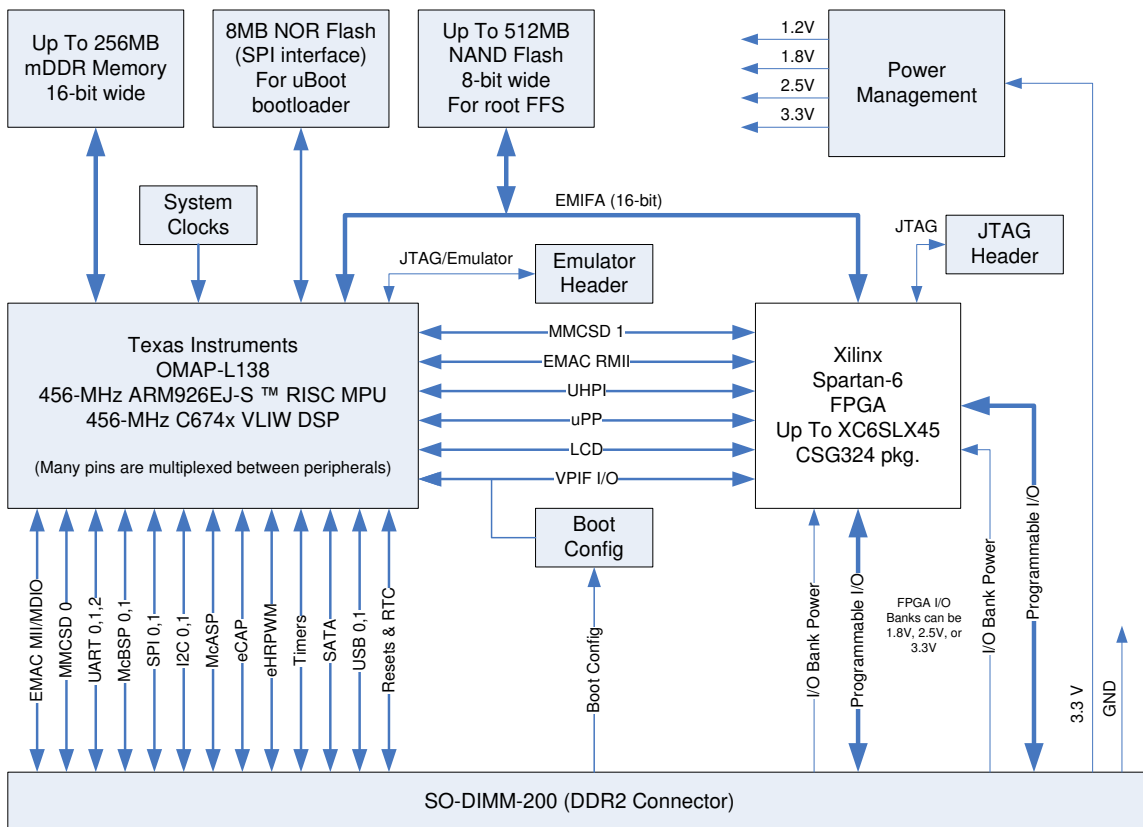

Figure 1 MityDSP-L138F Block Diagram

Figure 1 provides a top level block diagram of the MityDSP-L138F processor card. As shown in the figure, the primary interface to the MityDSP-L138F is through a standard SO-DIMM-200 card edge interface. The interface provides power, synchronous serial connectivity, and up to 96 pins of configurable FPGA I/O for application defined interfacing. Details of the SO-DIMM-200 connector interface are included in the SO-DIMM-200 Interface Description, as shown below.

FPGA Bank I/O

The MityDSP-L138F provides 96 lines of FPGA I/O directly to the SO-DIMM-200 card edge interface. The 96 lines of FPGA I/O are distributed across 2 banks of the FPGA. These I/O lines and their associated logic are completely configurable within the FPGA at the end user's discretion.

With the Xilinx Spartan-6 series FPGA, up to the XC6SLX45, each of the user controlled banks may be configured to operate on a different electrical interface standard based on input voltage provided at the card edge connector. The banks support 3.3V, 2.5V, and 1.8V standard CMOS switching level technology. In addition, the I/O lines from the FPGA have been routed as differential pairs and support higher speed LVDS standards as well as SSTL 2.5 switching standards. Various forms of termination (pull-up/pull-down, digitally controlled impedance matching) are available within the FPGA switch fabric. Refer to the Xilinx Spartan 6 user's guide for more information.

OMAP-L138 mDDR2 Memory Interface

The OMAP-L138 includes a dedicated DDR2 SDRAM memory interface shared between the onboard ARM and DSP cores. The MityDSP-L138F includes up to 256 MB of mDDR2 RAM integrated with the OMAP-L138 processor. The bus interface is capable of burst transfer rates of 600 MB / second. Note that the OSCIN frequency to the OMAP-L138 processor on the module is 24MHz.

OMAP-L138 SPI NOR FLASH Interface

The MityDSP-L138F includes 8 MB of SPI NOR FLASH. This FLASH memory is intended to store a factory provided bootloader, and typically a compressed image of a Linux kernel for the ARM core processor.

EMIFA - FPGA / NAND FLASH Interface

The OMAP-L138 and the Spartan-6 FPGA are connected using the DSP Asynchronous External Memory Interface (EMIFA). The EMIFA interface includes 3 chip select spaces. The EMIF interface supports multiple data width transfers and bus wait state configurations based on chip select space. 8, and 16 bit data word sizes may be used. Two of the three chip select lines (CE2, CE3) are reserved for the FPGA interface. The MityDSP-L138F also includes 4 lines between the FPGA and the OMAP for the purposes of generating interrupt signals.

In addition to the FPGA, up to 512 MB of on-board NAND FLASH memory is connected to the OMAP-L138 using the EMIFA bus. The FLASH memory is 8 bits wide and is connected to third chip select line of the EMIFA (CE1). The FLASH memory is typically used to store the following types of data:

- ARM Linux / Windows Embedded CE / QNX embedded root file-system
- FPGA application images
- runtime DSP or ARM software
- runtime application data (non-volatile storage)

OMAP-L138 Camera and Video Interfaces

The OMAP-L138 includes an optional video port I/O interface commonly used to drive LCD screens as well as a camera input interface. These interfaces have been routed to the FPGA, which may be routed to the FPGA output pins on the SO-DIMM-200 connector. By routing the video data through the FPGA, additional user customization and/or processing (e.g., overlays of video output, preprocessing or filtering of camera input) may be offloaded from the OMAP-L138 to the FPGA for computation intensive applications.

Debug Interface

Both the JTAG interface signals for the FPGA and the JTAG and emulator signals for the OMAP-L138 processor have been brought out to a Hirose header that is intended for use with an available Critical Link breakout adapter. This header can be removed for production units; please contact your Critical Link representative for details.

This adapter is not included with individual modules but is included with each Critical Link Development Kit that is ordered. If an adapter, Critical Link (CL) part number 80-000286, is needed please contact your Critical Link representative.

Software and Application Development Support

Users of the MityDSP-L138F are encouraged to develop applications and FPGA firmware using the MityDSP-L138F hardware and software development kit provided by Critical Link LLC. The development kit includes an implementation of an OpenEmbedded board support package providing an Angstrom based Linux distribution and compatible gcc compiler tool-chain with debugger. In addition, the development kit includes support libraries necessary to program the DSP core using the TI Code Composer Studio DSP compiler tool-chain.

To support rapid FPGA and applications development, netlist components - compatible with the Xilinx ISE FPGA synthesis tool – for commonly used FPGA designs and a corresponding set of Linux loadable kernel modules and/or DSP interface APIs are included. The libraries provide the necessary functions needed to configure the MityDSP-L138F, program standalone embedded applications, and interface with the various hardware components both on the processor board as well as a custom application carrier card. The libraries include several interface “cores” – FPGA and DSP software modules designed to interface with various high performance data converter modules (ADCs, DACs, LCD and touchscreen interfaces, etc) – as well as bootloading and FLASH programming utilities.

Growth Options

The OMAP-L138 has been designed to support several upgrade options. These options include various speed grades, memory configurations, and operating temperature specifications including commercial and industrial temperature ranges. The available options are listed in the section below containing ordering information. For additional ordering information and details regarding these options, or to inquire about a particular configuration not listed below, please contact a Critical Link sales representative.

ABSOLUTE MAXIMUM RATINGS

If Military/Aerospace specified cards are required, please contact the Critical Link Sales Office or unit Distributors for availability and specifications.

Maximum Supply Voltage, Vcc	3.5 V
Storage Temperature Range	-65°C to 80°C
Shock, Z-Axis	±10 g
Shock, X/Y-Axis	±10 g

OPERATING CONDITIONS

Ambient Temperature Range Commercial	0°C to 70°C
Ambient Temperature Range Industrial	-40°C to 85°C
Humidity	0 to 95% Non-condensing
MIL-STD-810F	Contact Critical Link for Details

SO-DIMM-200 Interface Description

The primary interface connector for the MityDSP-L138 is the SO-DIMM card edge interface which contains 4 types of signals:

Power (PWR)

Dedicated signals mapped to the OMAP-L138 device (D)

Multi-function signals mapped to the OMAP-L138 device (M)

Dedicated signals mapped to the Xilinx Spartan 6 device (F)

Table 1 contains a summary of the MityDSP-L138 pin mapping.

Table 1 SO-DIMM Pin-Out

Pin	Ball	Type	I/O	Signal	Pin	Ball	Type	I/O	Signal
1	-	PWR	-	+3.3 V in	2	-	PWR	-	+3.3 V in
3	-	PWR	-	+3.3 V in	4	-	PWR	-	+3.3 V in
5	-	PWR	-	+3.3 V in	6	-	PWR	-	+3.3 V in
7	-	PWR	-	GND	8	-	PWR	-	GND
9	-	PWR	-	GND	10	-	PWR	-	GND
11	K14	D	I	RESET_IN#	12	-	D		EXT_BOOT#
13	J1	D	O	SATA_TX_P	14	A4	M	I/O	GP0_7
15	J2	D	O	SATA_TX_N	16	A3	M	I/O	GP0_10
17	L1	D	I	SATA_RX_P	18	A2	M	I/O	GP0_11
19	L2	D	I	SATA_RX_N	20	A1	M	I/O	GP0_15
21	P16	D	I	USB0_ID	22	B4	M	I/O	GP0_6
23	P18	D	I/O	USB1_D_N	24	B1	M	I/O	GP0_14
25	P19	D	I/O	USB1_D_P	26	B2	M	I/O	GP0_12
27	N19	D	O	USB0_VBUS	28	B3	M	I/O	GP0_5
29	M18	D	I/O	USB0_D_N	30	C2	M	I/O	GP0_13
31	M19	D	I/O	USB0_D_P	32	C3	M	I/O	GP0_1
33	K18	D	O	USB0_DRVVBUS	34	C4	M	I/O	GP0_4
35	-	D	-	3V RTC Battery	36	C5	M	I/O	GP0_3
37	-	PWR	-	+3.3 V in	38	-	PWR	-	+3.3 V in
39	-	PWR	-	+3.3 V in	40	-	PWR	-	+3.3 V in

Pin	Ball	Type	I/O	Signal	Pin	Ball	Type	I/O	Signal
41	-	PWR	-	GND	42	-	PWR	-	GND
43	H17	D	I/O	SPI1_MISO	44	D4	M	I/O	GP0_2
45	G17	D	I/O	SPI1_MOSI	46	E4	M	I/O	GP0_0
47	H16	D	I/O	SPI1_ENA	48	F4	M	I/O	GP0_8
49 ¹	G19	D	I/O	SPI1_CLK	50	D5	M	I/O	GP0_9
51	F18	M	I/O	SPI1_SCS1	52	A12	M	I/O	MMCSD0_DAT7
53	-	D	I/O	Reserved	54	C11	M	I/O	MMCSD0_DAT6
55 ²	G16	D	I/O	I2C0_SCL	56	E12	M	I/O	MMCSD0_DAT5
57 ²	G18	D	I/O	I2C0_SDA	58	B11	M	I/O	MMCSD0_DAT4
59	F16	M	I/O	UART2_TXD / I2C1_SDA	60	E11	M	I/O	MMCSD0_DAT3
61	F17	M	I/O	UART2_RXD / I2C1_SCL	62	C10	M	I/O	MMCSD0_DAT2
63	-	PWR	I/O	GND	64	-	PWR	I/O	GND
65	F19	M	I/O	UART1_TXD	66	A11	M	I/O	MMCSD0_DAT1
67	E18	M	I/O	UART1_RXD	68	B10	M	I/O	MMCSD0_DAT0
69	E16	M	I/O	MDIO_CLK	70	A10	M	I/O	MMCSD0_CMD
71	D17	M	I/O	MDIO_DAT	72	E9	M	I/O	MMCSD0_CLK
73	D19	M	I/O	MII_RXCLK	74	D3	M	I/O	MII_TXCLK
75	C17	M	I/O	MII_RXDV	76	E3	M	I/O	MII_TXD3
77	D16	M	I/O	MII_RXD0	78	E2	M	I/O	MII_TXD2
79	E17	M	I/O	MII_RXD1	80	E1	M	I/O	MII_TXD1
81	D18	M	I/O	MII_RXD2	82	F3	M	I/O	MII_TXD0
83	C19	M	I/O	MII_RXD3	84	C1	M	I/O	MII_TXEN
85	-	PWR	-	GND	86	-	PWR	-	GND
87	C18	M	I/O	MII_CRS	88	D1	M	I/O	MII_COL
89	C16	M	I/O	MII_RXER	90 ⁴	R16	F	I/O	FPGA_SUSPEND
91	U17	F	I/O	B1_47_P.U17	92	M14	F	I/O	B1_48_P.M14
93	U18	F	I/O	B1_47_N.U18	94	N14	F	I/O	B1_48_N.N14
95	T17	F	I/O	B1_45_P.T17	96	N15	F	I/O	B1_46_P.N15
97	T18	F	I/O	B1_45_N.T18	98	N16	F	I/O	B1_46_N.N16
99	P17	F	I/O	B1_43_P.P17	100	L12	F	I/O	B1_44_P.L12
101	P18	F	I/O	B1_43_N.P18	102	L13	F	I/O	B1_44_N.L13
103	N17	F	I/O	B1_41_P.N17	104	K12	F	I/O	B1_42_P.K12
105	N18	F	I/O	B1_41_N.N18	106	K13	F	I/O	B1_42_N.K13
107	-	PWR	-	GND	108	-	PWR	-	GND
109	M16	F	I/O	B1_39_P.M16	110	L15	F	I/O	B1_40_P.L15
111	M18	F	I/O	B1_39_N.M18	112	L16	F	I/O	B1_40_N.L16
113	L17	F	I/O	B1_37_P.L17	114	K15	F	I/O	B1_38_P.K15
115	L18	F	I/O	B1_37_N.L18	116	K16	F	I/O	B1_38_N.K16
117	K17	F	I/O	B1_35_P.K17	118	J13	F	I/O	B1_36_P.J13
119	K18	F	I/O	B1_35_N.K18	120	K14	F	I/O	B1_36_N.K14
121	J16	F	I/O	B1_33_P.J16	122	H15	F	I/O	B1_34_P.H15
123	J18	F	I/O	B1_33_N.J18	124	H16	F	I/O	B1_34_N.H16
125	H17	F	I/O	B1_31_P.H17	126	H13	F	I/O	B1_32_P.H13
127	H18	F	I/O	B1_31_N.H18	128	H14	F	I/O	B1_32_N.H14
129	-	PWR	-	GND	130	-	PWR	-	GND
131	G16	F	I/O	B1_29_P.G16	132	F15	F	I/O	B1_30_P.F15
133	G18	F	I/O	B1_29_N.G18	134	F16	F	I/O	B1_30_N.F16
135	F17	F	I/O	B1_27_P.F17	136	H12	F	I/O	B1_28_P.H12
137	F18	F	I/O	B1_27_N.F18	138	G13	F	I/O	B1_28_N.G13



Pin	Ball	Type	I/O	Signal	Pin	Ball	Type	I/O	Signal
139	E16	F	I/O	B1_25_P.E16	140	F14	F	I/O	B1_26_P.F14
141	E18	F	I/O	B1_25_N.E18	142	G14	F	I/O	B1_26_N.G14
143	D17	F	I/O	B1_23_P.D17	144	F13	F	I/O	B0_24_P.F13
145	D18	F	I/O	B1_23_N.D18	146	E13	F	I/O	B0_24_N.E13
147	C17	F	I/O	B1_21_P.C17	148	D14	F	I/O	B0_22_P.D14
149	C18	F	I/O	B1_21_N.C18	150	C14	F	I/O	B0_22_N.C14
151	-	PWR	-	GND	152	-	PWR	-	GND
153	B16	F	I/O	B0_19_P.B16	154 ³	F12	F	I/O ³	B0_20_P.F12 ³
155	A16	F	I/O	B0_19_N.A16	156 ³	E12	F	I/O ³	B0_20_N.E12 ³
157	C15	F	I/O	B0_17_P.C15	158 ³	D12	F	I/O ³	B0_18_P.D12 ³
159	A15	F	I/O	B0_17_N.A15	160 ³	C12	F	I/O ³	B0_18_N.C12 ³
161	B14	F	I/O	B0_15_P.B14	162 ³	F11	F	I/O ³	B0_16_P.F11 ³
163	A14	F	I/O	B0_15_N.A14	164 ³	E11	F	I/O ³	B0_16_N.E11 ³
165	C13	F	I/O	B0_13_P.C13	166	D11	F	I/O	B0_14_P.D11
167	A13	F	I/O	B0_13_N.A13	168	C11	F	I/O	B0_14_N.C11
169	B12	F	I/O	B0_11_P.B12	170 ³	E7	F	I/O ³	B0_12_P.E7 ³
171	A12	F	I/O	B0_11_N.A12	172 ³	E8	F	I/O ³	B0_12_N.E8 ³
173	-	PWR	-	GND	174	-	PWR	-	GND
175	B11	F	I/O	B0_9_P.B11	176	D9	F	I/O	B0_10_P.D9
177	A11	F	I/O	B0_9_N.A11	178	C9	F	I/O	B0_10_N.C9
179	C10	F	I/O	B0_7_P.C10	180	D8	F	I/O	B0_8_P.D8
181	A10	F	I/O	B0_7_N.A10	182	C8	F	I/O	B0_8_N.C8
183	B9	F	I/O	B0_5_P.B9	184	D6	F	I/O	B0_6_P.D6
185	A9	F	I/O	B0_5_N.A9	186	C6	F	I/O	B0_6_N.C6
187	B8	F	I/O	B0_3_P.B8	188	B6	F	I/O	B0_4_P.B6
189	A8	F	I/O	B0_3_N.A8	190	A	F	I/O	B0_4_N.A6
191	C7	F	I/O	B0_1_P.C7	192	C5	F	I/O	B0_2_P.C5
193	A7	F	I/O	B0_1_N.A7	194	A5	F	I/O	B0_2_N.A5
195	-	PWR	-	GND	196	-	PWR	-	GND
197	-	PWR	-	VCCO_1	198	-	PWR	-	VCCO_0
199	-	PWR	-	VCCO_1	200	-	PWR	-	VCCO_0

Note 1: Pin 49, SPI1_CLK, has a 100K Ohm pull-down resistor on the module

Note 2: Pins 55 and 57 have 4.70K pull-up resistors on the module

Note 3: The Xilinx 6SLX45 FPGA does not bond I/O Buffers to balls E7, E8, F11, E11, D12, C12, E12, and F12 of the package used for this module. For MityDSP-L138F configurations using this FPGA option, these edge connector signals should be treated as no-connects and will not function as FPGA I/O lines.

Note 4: Pin 90, FPGA_SUSPEND, has a 4.7K Ohm pull-down resistor on the module

The signal group description for the above pins is included in Table 2.

Table 2 Signal Group Description

Signal / Group	I/O	Description
3.3 V in	N/A	3.3 volt input power referenced to GND.
EXT_BOOT#	I	Bootstrap configuration pin. Pull low to configure booting from external UART1.
RESET_IN#	I	Manual Reset. When pulled to GND for a minimum of 1 usec, resets the DSP processor.
SPI_XXXX	I/O	The pins with an SPI_ prefix are direct connections to the OMAP-L138 pins supporting the SPI1 interface. The SPI1_CLK, SPI1_ENA, SPI1_MISO, SPI1_MOSI pins must remain configured for the SPI function in order to support interfacing to the on-board SPI boot ROM. For details please refer to the OMAP-L138 processor specifications.
MII_XXXX	I/O	The pins with an MII_ prefix are direct connections to the OMAP-L138 pins supporting the media independent interface (MII) function. The MII pins provide multiplex capability and may alternately be used as UART, GPIO, and SPI control pins. For details please refer to the OMAP-L138 processor specification.
MDIO_XX	I/O	The MDIO_CLK and MDIO_DAT signals are direct connects to the corresponding MDIO signals on the OMAP-L138 processor. These pins may be configured for GPIO.
GP0_X	IO	General Purpose / multiplexed pins. These pins are direct connects to the corresponding GP0[X] pins on the OMAP-L138 processor. The include support for the McASP, general purpose I/O, UART flow control, and McBSP 1. For details please refer to the OMAP-L138 processor specifications.
SATA_TX_P/N	O	These pins are direct connects to the OMAP-L138 SATA_TX differential Serial ATA controller pins.
SATA_RX P/N	I	These pins are direct connects to the OMAP-L138 SATA_RX differential Serial ATA controller pins.
GND	N/A	System Digital Ground.
BX_Y_P.ZZ, BX_Y_N.ZZ	IO	FPGA I/O pins. These pins are routed directly to FPGA pins ZZ. The "X" indicates which FPGA bank the pin is allocated. The bank is either 0 or 1. The FPGA fabric supports routing pins in differential pairs, the Y_P and Y_N portion of the name indicates the pair number and polarity. The pins have been routed in pairs with phase matched line lengths.
VCCO_X	I	FPGA Bank interface power input. These pins must

Signal / Group	I/O	Description
		be tied to the desired voltage used for the FPGA Bank 0 or 1 interface pins. Please refer to the VCCO input pin specifications for the Xilinx Spartan 6 family of devices for further information. Typical values are 3.3V and 2.5 volts.
USB0_XXXX, USB1_XXXX	I/O	The USBN_ prefixed pins are direct connects to the corresponding pins on the OMAP-L138 processor. For details please refer to the OMAP-L138 processor specifications.

DEBUG INTERFACE

Below is the pin-out for the Hirose 31 pin header (DF9-31P-1V(32)) that interfaces with an available adapter board, CL part number 80-000286, to debug the OMAP-L138 and FPGA.

Debug Interface Connector Description (J2)

Table 3 OMAP-L138 Hirose Connector

Pin	I/O	Signal	Pin	I/O	Signal
1	-	GND	2	O	OMAP EMU1
3	-	GND	4	O	OMAP EMU0
5	-	GND	6	I	OMAP TCK
7	-	GND	8	O	OMAP RTCK
9	-	GND	10	O	OMAP TDO
11	-	GND	12	-	OMAP VCC / 3.3V
13	-	GND	14	I	OMAP TDI
15	-	GND	16	I	OMAP TRST
17	-	GND	18	I	OMAP TMS
19	-	GND	20	-	GND
21	-	GND	22	O	FPGA VREF / VCCAUX
23	-	GND	24	I	FPGA TMS
25	-	GND	26	I	FPGA TCK
27	-	GND	28	O	FPGA TDO
29	-	GND	30	I	FPGA TDI
31	-	GND			

ELECTRICAL CHARACTERISTICS

Table 4: Electrical Characteristics

Symbol	Parameter	Conditions	Min	Typ	Max	Units
V33	Voltage supply, 3.3 volt input.		3.2	3.3	3.4	Volts
I33	Quiescent Current draw, 3.3 volt input			TBS	TBS	mA
I33-max	Max current draw, positive 3.3 volt input.			TBS	TBS	mA
FCPU	CPU internal clock Frequency (PLL output)		25	300	456	MHz
FEMIF	EMIF bus frequency	Must be ½ CPU	-	100	-	MHz
1. Power utilization of the MityDSP-L138F is heavily dependent on end-user application. Major factors include: ARM CPU PLL configuration, DSP Utilization FPGA utilization, and external DDR2 RAM utilization.						

ORDERING INFORMATION

The following table lists the standard module configurations. For shipping status, availability, and lead time of these or other configurations please contact your Critical Link representative.

Table 5: Standard Model Numbers

Model	ARM and DSP Speed	FPGA	NOR Flash	NAND Flash	RAM	Operating Temp
L138-FG-225-RC	456 MHz	6SLX16	8MB	256MB	128MB	0°C to 70°C
L138-DG-225-RI	375 MHz	6SLX16	8MB	256MB	128MB	-40°C to 85°C
L138-FI-225-RC	456 MHz	6SLX45	8MB	256MB	128MB	0°C to 70°C
L138-DI-225-RI	375 MHz	6SLX45	8MB	256MB	128MB	-40°C to 85°C
L138-FI-236-RL	456 MHz	6SLX45	8MB	512MB	256MB	-40°C to 70°C

MECHANICAL INTERFACE

The mechanical outline of the MityDSP-L138F is illustrated in Figure 2, as shown below.

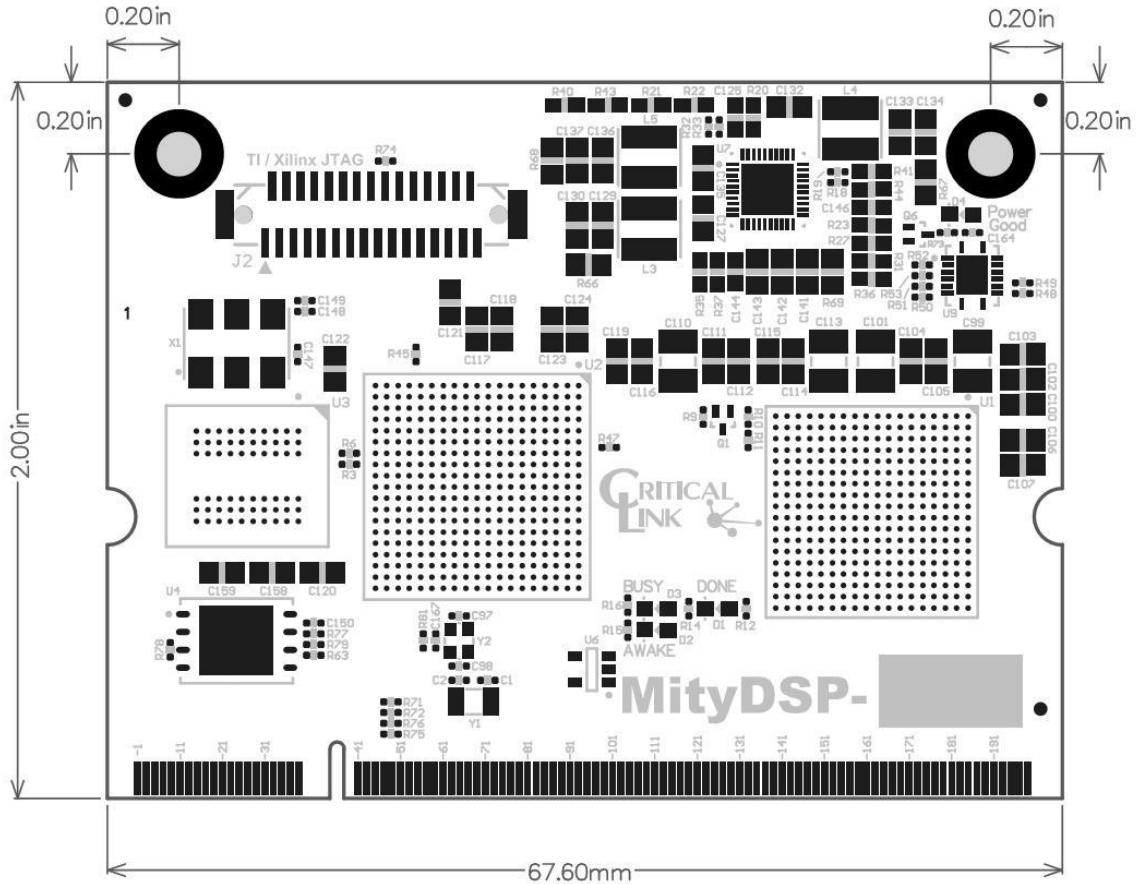

Figure 2 MityDSP-L138F Mechanical Outline

REVISION HISTORY

Date	Change Description
7-NOV-2009	Preliminary Draft, product overview
10-NOV-2009	Updates after initial review.
15-JAN-2010	Updates to features, applications and benefits
16-MAR-2010	Finalize connector pin-outs. Update mechanical outlines.
6-APR-2010	Update product photo and speed grade.
21-APR-2010	Update specifications and options.
26-JUL-2010	Update ordering information, images and mechanical drawing.
11-FEB-2011	Correct edge connector Table 1. Update speed grade to max 456 MHz. Updated DDR rate to support 150 MHz clocking. Update model p/n table.
02-JUN-2011	Update edge connector Table 1 to indicate unavailable FPGA pins for 6SLX45 options.
12-JUL-2011	Update NAND to indicate 8 bit data width. Update block diagram accordingly.
28-NOV-2011	Update list of orderable part numbers.
13-AUG-2012	Fix typo in signal names for pins 79, 81, 83, and 84
11-DEC-2012	Update Debug Header information, added MIL-STD-810F and Up To notation for RAM and NAND
29-AUG-2013	Added OMAP-L138 processor pins and FPGA pins to Table 1 with notes about on module resistors for specific pins as well as the OSCIN frequency.