



Chipsmall Limited consists of a professional team with an average of over 10 year of expertise in the distribution of electronic components. Based in Hongkong, we have already established firm and mutual-benefit business relationships with customers from,Europe,America and south Asia,supplying obsolete and hard-to-find components to meet their specific needs.

With the principle of “Quality Parts,Customers Priority,Honest Operation,and Considerate Service”,our business mainly focus on the distribution of electronic components. Line cards we deal with include Microchip,ALPS,ROHM,Xilinx,Pulse,ON,Everlight and Freescale. Main products comprise IC,Modules,Potentiometer,IC Socket,Relay,Connector.Our parts cover such applications as commercial,industrial, and automotives areas.

We are looking forward to setting up business relationship with you and hope to provide you with the best service and solution. Let us make a better world for our industry!



## Contact us

Tel: +86-755-8981 8866 Fax: +86-755-8427 6832

Email & Skype: info@chipsmall.com Web: www.chipsmall.com

Address: A1208, Overseas Decoration Building, #122 Zhenhua RD., Futian, Shenzhen, China



This document is the property of Amphenol Corporation and is delivered on the express condition that it is not to be disclosed, reproduced or used, in whole or in part, for manufacture or sale by anyone other than Amphenol Corporation without its prior consent, & that no right is granted to disclose or to use any information in this document.

# Customer drawing

REVISIONS				
SYM	ECN	DESCRIPTION	DATE	APPROVED
1			09/04/08	

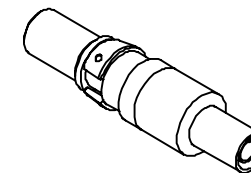
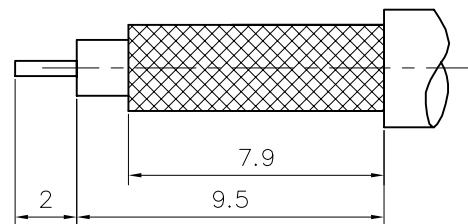
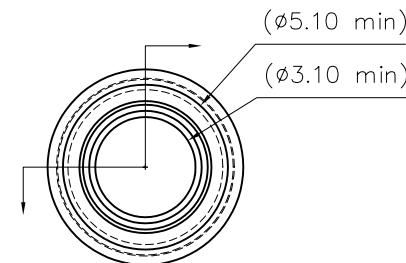
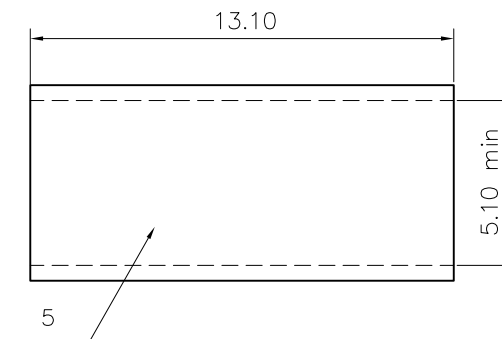
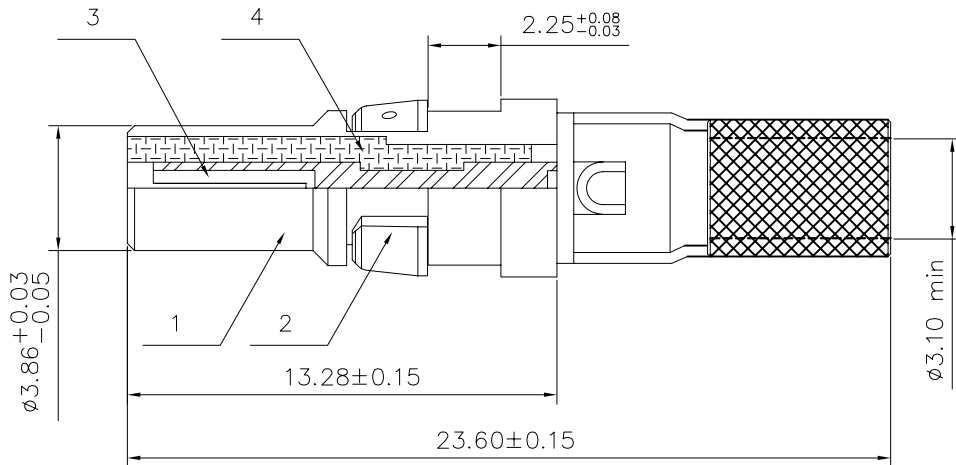

Trim cable

## MECHANICAL

- Materials: refer to the table
- Finish: refer to the table

## ELECTRICAL :

- Impedance: 50 Ohms Nominal
- Frequency Range: 0 to 5.0 GHz
- Insulation Resistance: 5000 Megaohms Minimum
- Contact Resistance: (Milliohms maximum)
- Center Contact: 5.0
- Outer Contact: 3.0
- Voltage Standing Wave Ratio: 0 to 5.0 GHz

## ENVIRONMENTAL

- Operating Temperature range : -55 °C up to +125°C
- Vibration: MIL-STD-202, Method 204, Test Condition D
- Shock: MIL-STD-202, Method 213, Test Condition I
- Corrosion Resistance: MIL-STD-202, Method 101, Test Condition B



Sequence	Material	Remark
5	ferrule	brass, gold over 50u" min. nickel
4	insulator	PTFE, Color white
3	center contact	phosphor bronze, 30u" min. gold over 50u" min. nickel
2	ring	thermoplastic, Color black
1	outer contact	brass, gold over 50u" min. nickel

UNLESS OTHERWISE SPECIFIED TOLERANCES		APPROVAL		DATE
U.S.	METRIC	DRAWN	Checked	
.X +/-	0.20	Mary.ma	09/04/08	
.XX +/-	0.10	Uk.wang	09/04/08	
.XXX +/-	0.05	CHECKED		
FRACTIONS +/-				
ANGLES +/-	2'			
FOR MATERIALS AND FINISHES SEE NOTES		DRAWING FILE :		
REMOVE SHARP EDGES		ANGLE OF PROJECTION		
DIMENSIONS				
U.S.	INCHES			
METRIC	MM			

<b>Amphenol®</b>		
TITLE Straight shielded contacts Crimp ferrule		
SIZE	DRAWING NO.	REV.
A4	C L17DM537405	1
SCALE	NONE	SHEET 1 OF 1