



Chipsmall Limited consists of a professional team with an average of over 10 year of expertise in the distribution of electronic components. Based in Hongkong, we have already established firm and mutual-benefit business relationships with customers from,Europe,America and south Asia,supplying obsolete and hard-to-find components to meet their specific needs.

With the principle of “Quality Parts,Customers Priority,Honest Operation,and Considerate Service”,our business mainly focus on the distribution of electronic components. Line cards we deal with include Microchip,ALPS,ROHM,Xilinx,Pulse,ON,Everlight and Freescale. Main products comprise IC,Modules,Potentiometer,IC Socket,Relay,Connector.Our parts cover such applications as commercial,industrial, and automotives areas.

We are looking forward to setting up business relationship with you and hope to provide you with the best service and solution. Let us make a better world for our industry!



Contact us

Tel: +86-755-8981 8866 Fax: +86-755-8427 6832

Email & Skype: info@chipsmall.com Web: www.chipsmall.com

Address: A1208, Overseas Decoration Building, #122 Zhenhua RD., Futian, Shenzhen, China





Caractéristique électrique:
 Impédance : 50 Ohms
 Résistance à l'isolement : 10^3 M Ohms
 Tension de travail : 500 Veff/50 Hz
 Tension maxi : 750 Veff/50 Hz
 Courant maxi : 1,5 A
 Fréquence d'utilisation : 0-2 Ghz

Caractéristique mécanique :
 Nbr de manoeuvres : maxi 400
 Effort d'insertion : maxi 10 N
 Effort d'extraction : mini 3 N
 Température d'utilisation : -55C° , +125C°

Dénudage câble:

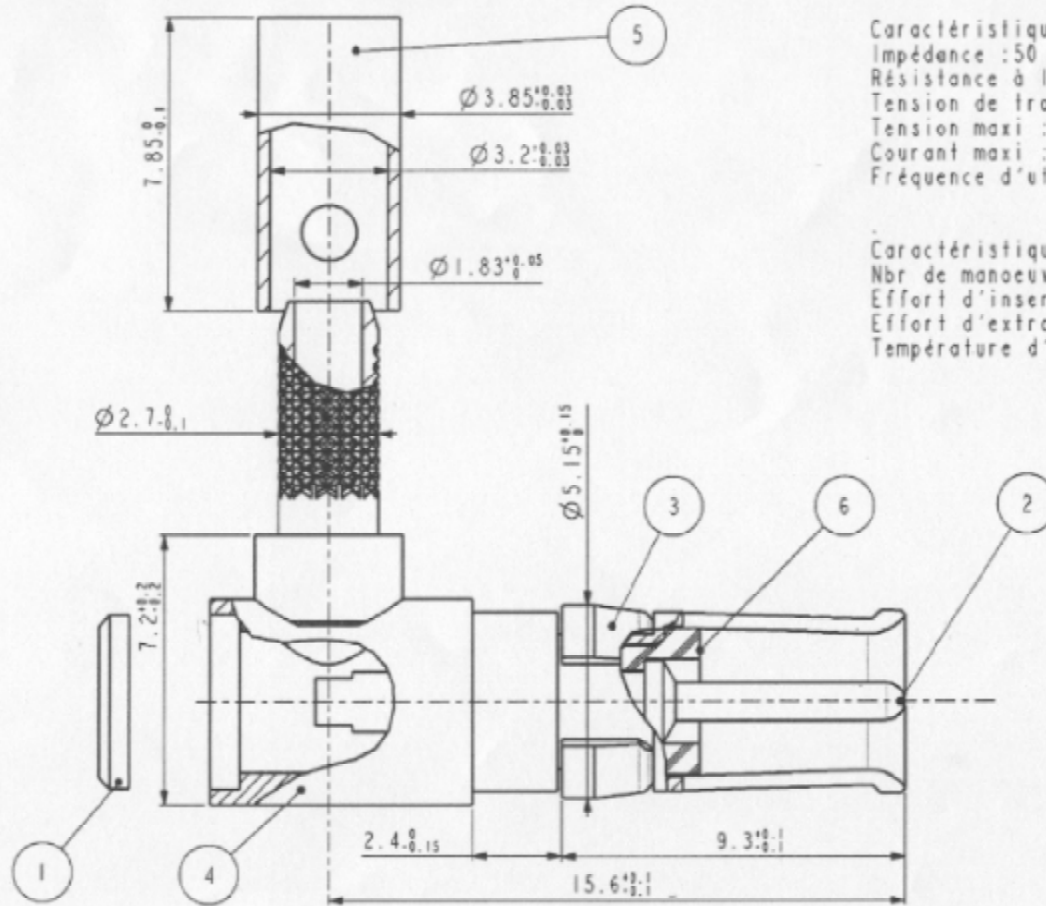
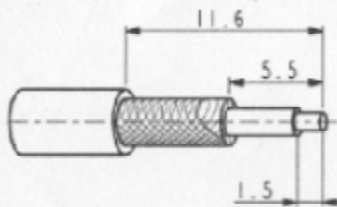

ECHELLE 1.000

Rep	Désignation	Qté	Matériau	Traitement	Protection
6	ISOLANT	1	PTFE		
5	FERULE	1	Cu Zn 40 Pb 3		
4	CORPS BRASE	1	Cu Ni1 Pb1 P (C97)		Au = 0.8 µ mini
3	CLIP	1	Cu Be 2	380 HV mini	Ni = 3 µ mini
2	BROCHE	1	Cu Zn 40 Pb 3		Au = 0.8 µ mini
1	BOUCHON	1	Cu Zn 40 Pb 3		Au = flash

1076

L17D M53743 5001
 Detailed drawing