



Chipsmall Limited consists of a professional team with an average of over 10 year of expertise in the distribution of electronic components. Based in Hongkong, we have already established firm and mutual-benefit business relationships with customers from,Europe,America and south Asia,supplying obsolete and hard-to-find components to meet their specific needs.

With the principle of "Quality Parts,Customers Priority,Honest Operation,and Considerate Service",our business mainly focus on the distribution of electronic components. Line cards we deal with include Microchip,ALPS,ROHM,Xilinx,Pulse,ON,Everlight and Freescale. Main products comprise IC,Modules,Potentiometer,IC Socket,Relay,Connector.Our parts cover such applications as commercial,industrial, and automotives areas.

We are looking forward to setting up business relationship with you and hope to provide you with the best service and solution. Let us make a better world for our industry!



## Contact us

Tel: +86-755-8981 8866 Fax: +86-755-8427 6832

Email & Skype: info@chipsmall.com Web: www.chipsmall.com

Address: A1208, Overseas Decoration Building, #122 Zhenhua RD., Futian, Shenzhen, China



REV.	DESCRIPTION	DATE	APPROVED
G	Engineering Release	10/03/12	T. Y.
H	Engineering Update w/o Changes	08/08/16	J. C.

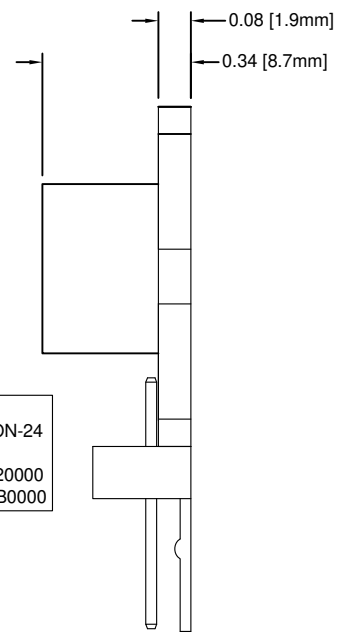
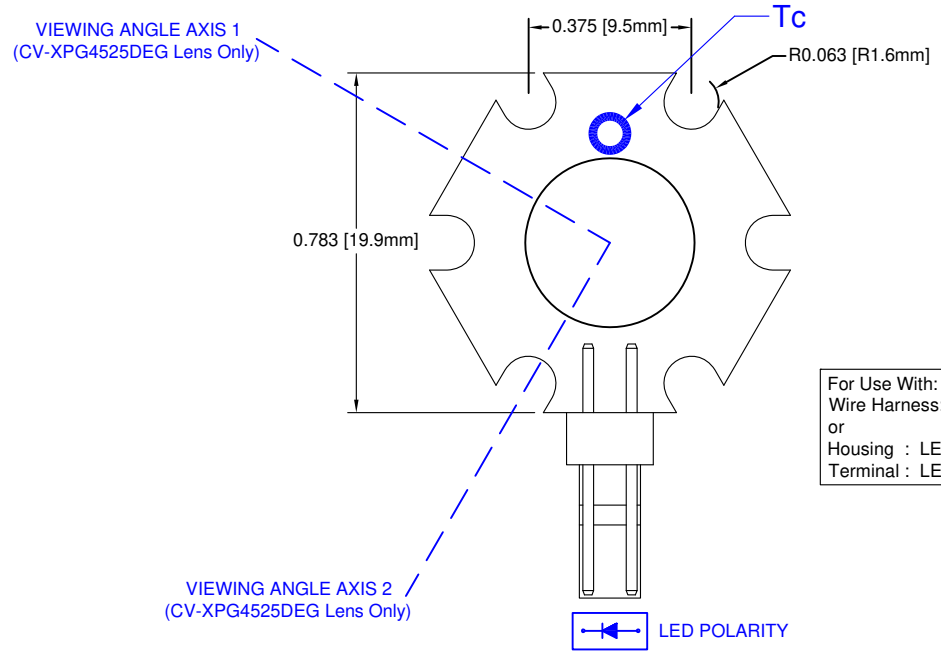

For Use With:  
 Wire Harness: BIVAR L2CON-24  
 or  
 Housing : LEOCO 2530S020000  
 Terminal : LEOCO 2533TPB0000

Part Number	CCT (K)	CRI	Typical Luminous Flux @ If = 350mA, Tc=70C (lm)	Typical Luminous Flux @ If = 600mA, Tc=100C (lm)	Typical DC Forward Current, Vf (V)	Viewing Angle, Axis 1 / Axis2 (°)
L2-PGC1-F	6500	75	97	152	2.9 ~ 3.0	85
L2-PGC2-F	6500	75	97	152	2.9 ~ 3.0	35
L2-PGC3-F	6500	75	97	152	2.9 ~ 3.0	45 / 25
L2-PGN1-F	4100	75	91	142	2.9 ~ 3.0	85
L2-PGN2-F	4100	75	91	142	2.9 ~ 3.0	35
L2-PGN3-F	4100	75	91	142	2.9 ~ 3.0	45 / 25
L2-PGW1-F	3100	80	80	125	2.9 ~ 3.0	85
L2-PGW2-F	3100	80	80	125	2.9 ~ 3.0	35
L2-PGW3-F	3100	80	80	125	2.9 ~ 3.0	45 / 25

Part Number	CCT (K)	CRI	Typical Luminous Flux @ If = 1000mA, Tc=120C (lm)	Typical Luminous Flux @ If = 1500mA, Tc=100C (lm)	Typical DC Forward Current, Vf (V)	Viewing Angle, Axis 1 / Axis2 (°)
L2-PGC1-F	6500	75	216	660	3.2 ~ 3.3	85
L2-PGC2-F	6500	75	216	660	3.2 ~ 3.3	35
L2-PGC3-F	6500	75	216	660	3.2 ~ 3.3	45 / 25
L2-PGN1-F	4100	75	186	566	3.2 ~ 3.3	85
L2-PGN2-F	4100	75	186	566	3.2 ~ 3.3	35
L2-PGN3-F	4100	75	186	566	3.2 ~ 3.3	45 / 25
L2-PGW1-F	3100	80	155	472	3.2 ~ 3.3	85
L2-PGW2-F	3100	80	155	472	3.2 ~ 3.3	35
L2-PGW3-F	3100	80	155	472	3.2 ~ 3.3	45 / 25

STANDARD TOLERANCE ( UNLESS OTHERWISE SPECIFIED )	
DECIMALS	ANGULAR
.X ± .1	X° ± 1°
.XX ± .02	
.XXX ± .010	

**BIVAR**<sup>®</sup>  
 4 THOMAS, IRVINE, CA. 92618  
 TEL.: (949) 951-8808 FAX: (949) 951-3974



**TITLE:** L2 Starboard Light Engine

DESIGNED:  
**B. Oliver**

DATE:  
**11/02/11**

**PART NO:** L2-PGXX-F

REVISION:  
**H**

CHECKED:  
**M. Chen**

DATE:  
**11/02/11**

**CAGE CODE : 32559 SHEET # 1 OF 1**  
 CAD GENERATED DOCUMENT. DO NOT MEASURE DRAWING.