



Chipsmall Limited consists of a professional team with an average of over 10 year of expertise in the distribution of electronic components. Based in Hongkong, we have already established firm and mutual-benefit business relationships with customers from,Europe,America and south Asia,supplying obsolete and hard-to-find components to meet their specific needs.

With the principle of “Quality Parts,Customers Priority,Honest Operation,and Considerate Service”,our business mainly focus on the distribution of electronic components. Line cards we deal with include Microchip,ALPS,ROHM,Xilinx,Pulse,ON,Everlight and Freescale. Main products comprise IC,Modules,Potentiometer,IC Socket,Relay,Connector.Our parts cover such applications as commercial,industrial, and automotives areas.

We are looking forward to setting up business relationship with you and hope to provide you with the best service and solution. Let us make a better world for our industry!



Contact us

Tel: +86-755-8981 8866 Fax: +86-755-8427 6832

Email & Skype: info@chipsmall.com Web: www.chipsmall.com

Address: A1208, Overseas Decoration Building, #122 Zhenhua RD., Futian, Shenzhen, China



HALL-EFFECT PICKUP IGNITION CONTROLLER

- DIRECT DRIVING OF THE EXTERNAL POWER DARLINGTON
- COIL CURRENT CHARGING ANGLE (DWELL) CONTROL
- COIL CURRENT PEAK VALUE LIMITATION
- CONTINUOUS COIL CURRENT PROTECTION
- CONDUCTION AND DESATURATION TIME OUTPUT SIGNALS
- PERMANENT CONDUCTION PROTECTION RESET OUTPUT SIGNAL
- OVERVOLTAGE PROTECTION FOR EXTERNAL DARLINGTON
- LOAD DUMP PROTECTION

DESCRIPTION

The L482 is an integrated circuit designed for use with an NPN darlington in breakerless ignition systems with hall-effect pickup sensors and high energy ignition coils.

It controls the energy stored in the ignition coil and the desaturation time of the external darlington to limit the power dissipation.

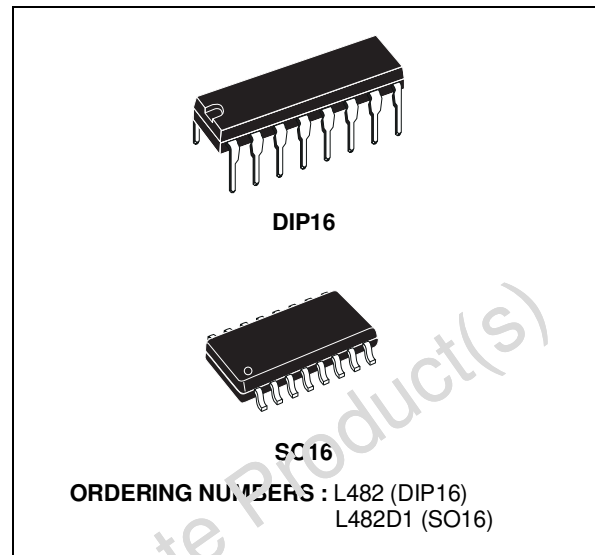

The L482 is also particularly suitable for use as ignition control and driving stage in more sophisticated car electronic systems which employ microprocessor circuits.

PIN CONNECTIONS (top views)

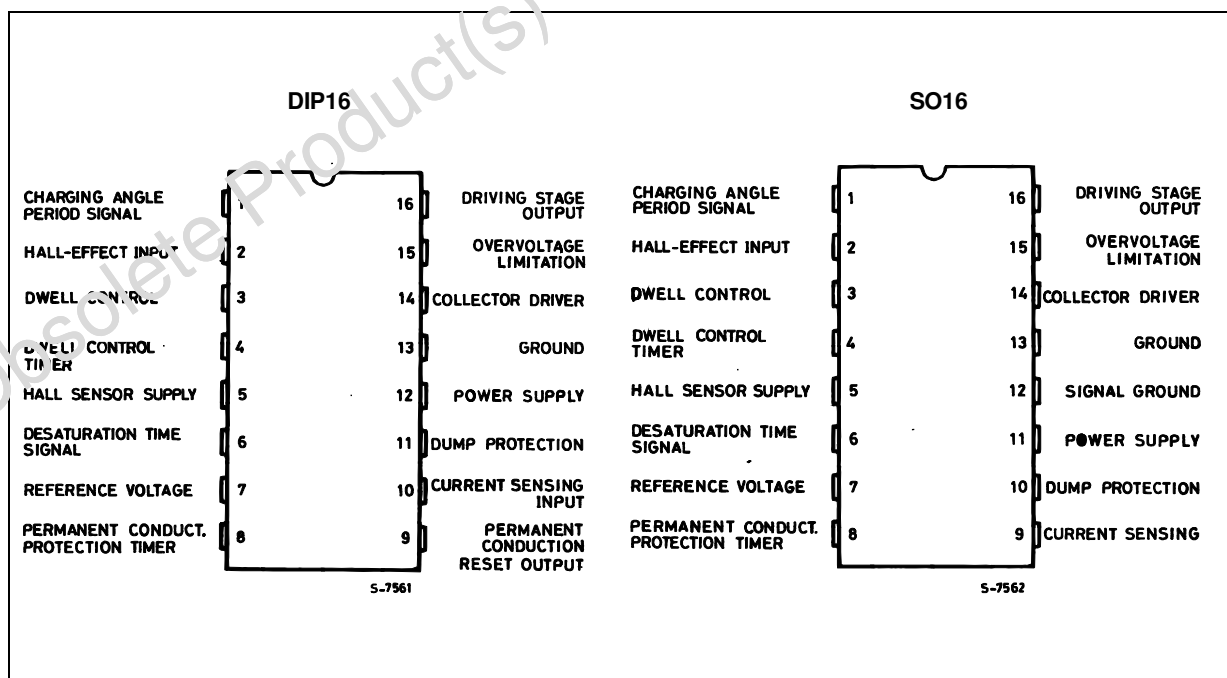

ABSOLUTE MAXIMUM RATINGS

Symbol	Parameter	Value	Unit
V_R	Reverse Battery Voltage	- 14	V
V_D	Dump Voltage	100	V
P_{tot}	Power Dissipation at $T_{amb} = 90^\circ\text{C}$	SO16 DIP 1.2 0.65	W W
T_j, T_{stg}	Junction and Storage Temperature Range	- 55 to 150	$^\circ\text{C}$

BLOCK DIAGRAM

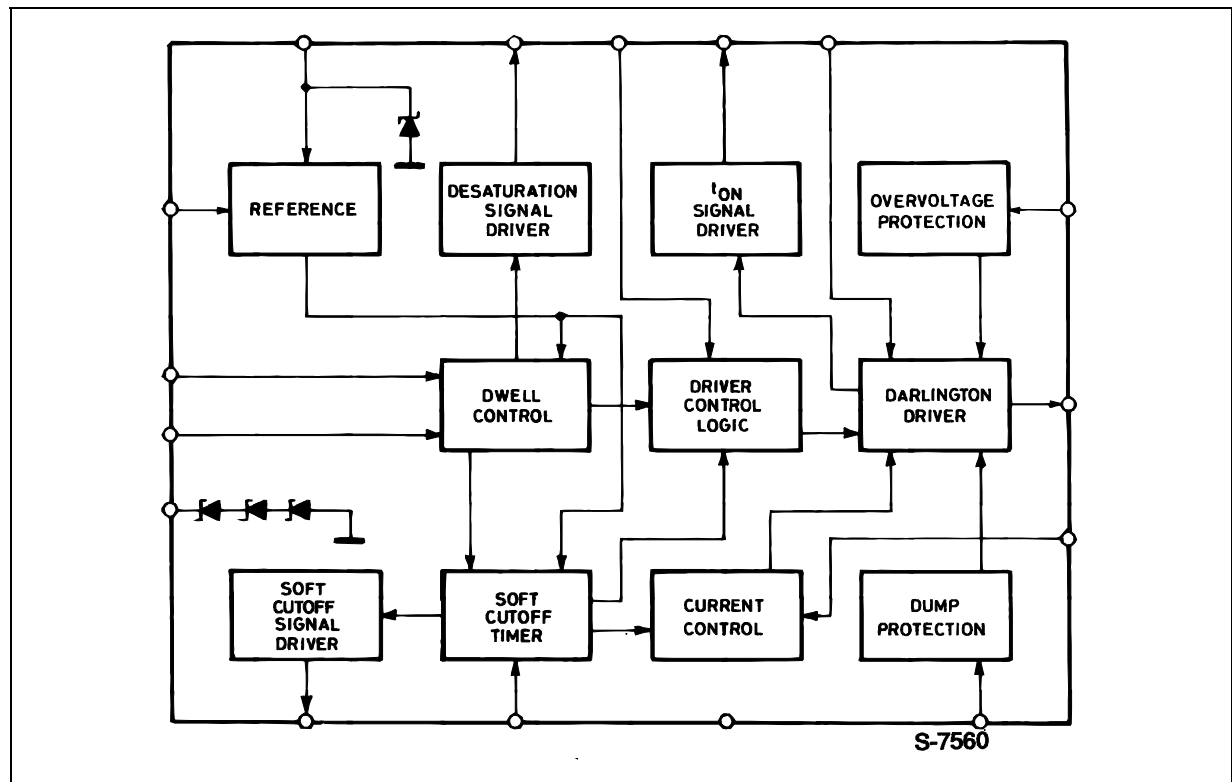

THERMAL DATA

Symbol	Parameter	Value	Unit
$R_{th j-amb}$	Thermal Resistance Junction-ambient (DIP16)	Max 90	$^\circ\text{C}/\text{W}$
$R_{th j-al}$	Thermal Resistance Junction-alumina (SO16)	Max 50	$^\circ\text{C}/\text{W}$

(*) Thermal resistance junction-alumina with the device soldered on the middle of an alumina supporting substrate measuring 15 x 20mm ; 0.65mm thickness with infinite heatsink.

PIN FUNCTIONS (refer to fig. 3 for DIP16 package)

N°	Name	Function
1	CONDUCTION TIME SIGNAL	A low level on this output signal indicates when the external darlington is in the ON condition i.e. when the current flows through the coil (ton in fig.1)
2	HALL-EFFECT INPUT	Hall-effect Pickup Input. A high level on this pin enables the current driving into the coil. The effective coil charge will be a function of the dwell control logic. A High to Low transition from the Hall-effect pickup is the signal for ignition actuation. The input signal, supplied by the open collector output stage of the Hall-effect sensor, has a duty cycle typically about 70%.
3	DWELL CONTROL	The average voltage on the capacitor C ₂ connected between this pin and ground depends on the motor speed and the voltage supply. The comparison between V _{C2} and V _{C5} voltages determines the timing for the dwell control. The recommended value is 100nF using a 100KΩ resistor at pin 7. For the optimized operation of the device, C ₂ = C ₅ .
4	DWELL CONTROL TIMER	The capacitor C ₅ connected between this pin and ground is charged when the Hall-effect output is high and is discharged at the High to Low transition of the Hall-effect signal. The recommended value is 100nF using a 100KΩ resistor at pin 7.
5	HALL SENSOR SUPPLY	This pin can be used to project the Hall-effect pickup against the voltage transients, The resistor R _a limits the current into the internal zener.
6	DESATURATION TIME SIGNAL	Open Collector Output Signal. This output is high when the external darlington is in desaturation condition (current limitation), see t _d pulse in fig. 1.
7	REFERENCE VOLTAGE	A resistor R ₁₁ connected between this pin and ground sets the internal current used to drive the external capacitors of the dwell control (C ₂ and C ₅) and permanent conduction protection (C ₁). The recommended value is 100KΩ.
8	PERMANENT CONDUCT. PROTECTION TIMER	A capacitor C ₁ connected between this pin and ground determines the intervention delay of the permanent conduction protection, t _{pc} of the figure 2. With a 1μF capacitor and 100KΩ resistor R ₁₁ at pin 7 the typical delay is 1s.
9	PERMANENT CONDUCT. RESET OUTPUT (no available in Micropackage) (*)	A low pulse on this output detects the intervention of the permanent conduction protection, as shown in figure 2. Typically the duration of the time t _r is more than 100μs.
10	CURRENT SENSING INPUT (*)	Connection for Coil Current Limitation. The current is measured on the sense resistor R _S and divided on R ₁ /R ₂ . The current limitation value is given by : $I_{SENS} = V_{SENS} \frac{R_1 + R_2}{R_S \cdot R_2}$
11	DUMP PROTECTION (*)	The device is protected against the load dump. In load dump condition an internal circuit, based on a zener diode and a darlington transistor, switches off the external darlington and short circuits the supply. By means of the external divider R ₈ /R ₉ the protection threshold can be changed and is given as first approximation by: $V_{Dth} = 8.5 \cdot \left(\frac{R_8 + R_9}{R_9} \right) + 5 \cdot 10^{-4} \cdot R_8$ (the resistor R ₉ value must be higher than 4KΩ).
12	POWER SUPPLY (*)	Supply Voltage Input. A 7V (typ) zener is present at the input. The external resistor R ₇ limits the current through the Zener for high supply voltages.

PIN FUNCTIONS (continued)

N°	Name	Function
13	GROUND	This pin must be connected to ground.
14	DRIVER COLLECTOR	The collector current for the internal driver which drives the external darlington is supplied through this pin. The external resistor R ₁₀ limits the dissipation in the IC. The value of the resistor depends is a function of the darlington used and on the limiting current in the coil.
15	OVERVOLTAGE LIMITATION	The external is protected against overvoltage by means of an internal zener available at this pin. The external divider R ₅ /R ₆ defines the limitation value, given as first approximation by: $V_{ovp} = \left(\frac{30}{R_5} + 5 \cdot 10^{-3} \right) \cdot R_6 + 30$
16	DRIVING STAGE OUTPUT	Current Driver for the External Darlington. To ensure stability and precision of Tdesat C ₃ and R ₃ must be used. Recommended value for R3 is 2KΩ in order not to change the open loop gain of the system. R _C may be added to C ₃ to obtain greater flexibility in various application situations. C ₃ and RC values ranges are 1 to 100nF and 5 to 30KΩ depending on the external darlington type.

(*) These pins refer only to the DIP package type.

For the SO 16 version the permanent conduction reset output signal is not available and the pin 9 becomes the current sensing input. Pin 10 replaces the pin 11 function, pin 11 becomes the power supply input and pin 12 is used as the signal ground.

ELECTRICAL CHARACTERISTICS (V_S = 14 V, -40°C ≤ T_j ≤ 125°C referred to application circuit of figure 3 regarding DIP-16 package version)

Symbol	Parameter	Test Conditions	Min.	Typ.	Max.	Unit
V _S	Operating Supply Voltage		6		28	V
I _S	Supply Current	V ₁₂ = 4.5V			25	mA
V _Z	Zener Voltage (pin 12)	I _Z = 80mA	6.5		8.8	V
V _I	Sensor Input (pin 2) LOW Voltage HIGH		2.5		0.5	V V
I _I	Sensor Input Current (pin 2)	V _I = LOW V _S = 6 to 16V	-12		-1	mA
V _{HZ}	Hall-cell Supply Zener Voltage (pin5)	I _{HZ} = 10mA	19	22	25	V
I _{HZ}	Hall-cell Supply Zener Current (pin5)	t = 10ms T _{AMB} = 25°C	100			mA
V _{CE sat} (V ₁₄ -V ₁₆)	Series Darlington Driver Sat. Voltage	I _o = 70mA I _o = 150mA		0.4	0.6 1.0	V V
V _{SENS}	Current Limit. Sensing Voltage (pin10)	V _S = 6 to 16V	200		400	mV
I _{3D} I _{3C} I _{3C} /I _{3D}	C2 Discharge Current C2 Charge Current	V _S = 6 to 16V (*) Note 1	0.2 5 6		3.4 20 35	μA μA
V _{OVZ}	External Darlington Overvoltage Protection Zener Voltage	I _{ovZ} = 5mA to 15mA T _{AMB} = 25°C	25	30	35	V
V ₇	Reference Voltage		2.5		3.5	V
t _d	Desaturation Time	f = 40Hz V _S = 14V	0.6	1.2	1.57	ms

ELECTRICAL CHARACTERISTICS (Continued)

Symbol	Parameter	Test Conditions	Min.	Typ.	Max.	Unit
t_{PC}	Permanent Conduction Protection Time (pin 8) (see fig. 2)	$V_1 = H$ $C_1 = 1\mu F$	1	3	5	s
V_1	Charging Angle Output Voltage LOW HIGH	$I_{SINK} = 0$ $I_{SINK} = 1mA$ $I_{SOURCE} = 1.5mA$ $I_{SOURCE} = 2.5mA$			0.5 1.2	V V V V
V_6	Desat. Time Output Low Voltage	$I_6 (sink) = 0.5mA$			0.7	V
I_{6L}	Desat. Time Leakage Current (pin6)	$V_6 = 5V$			10.5	μA
I_{9L}	Permanent Conduction Reset Leakage Current (pin9)	$V_9 = 5V$			10.5	μA

APPLICATION INFORMATION

Figure 1 : Main Waveforms.

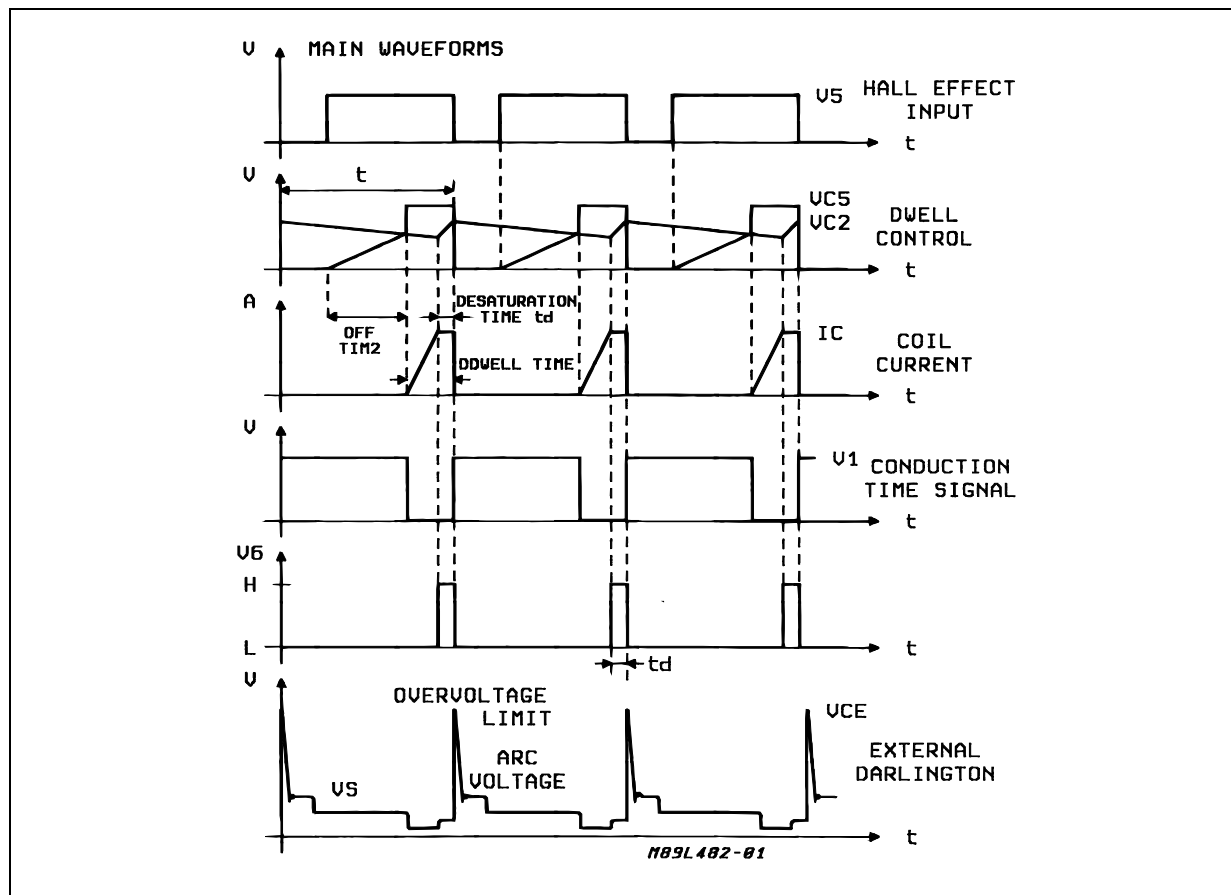

Figure 2 : Low Frequency Condition and Permanent Conduction Protection.

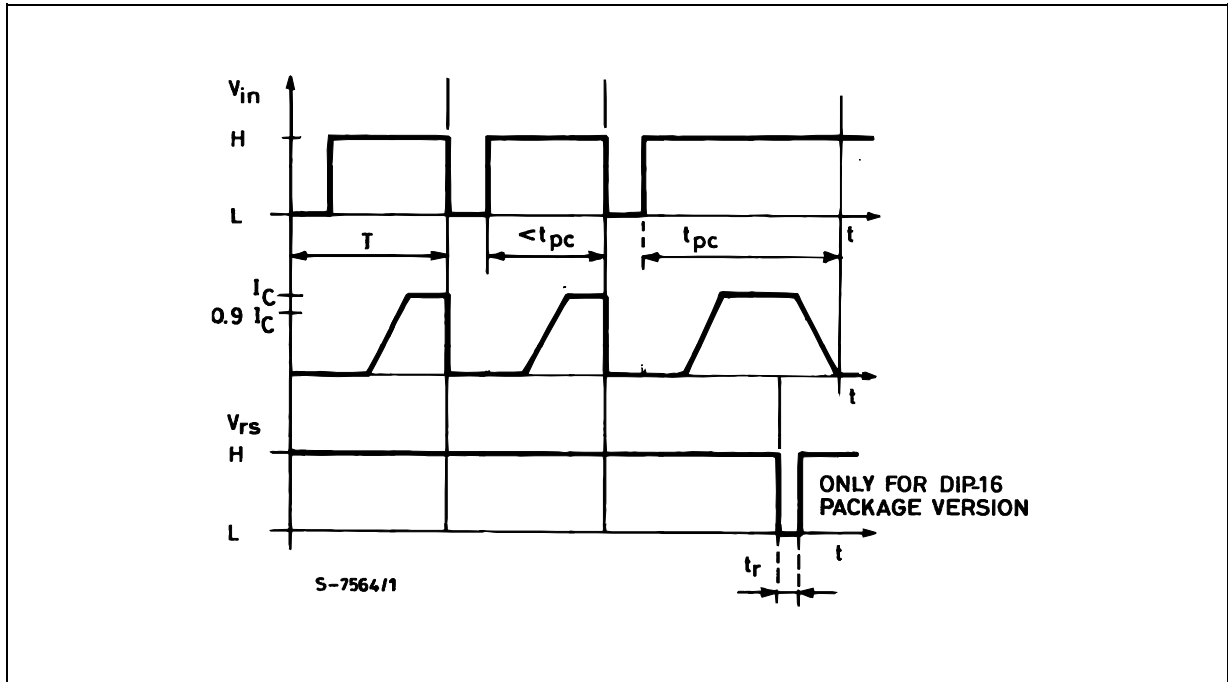

Figure 3 : Application circuit (DIP-16).

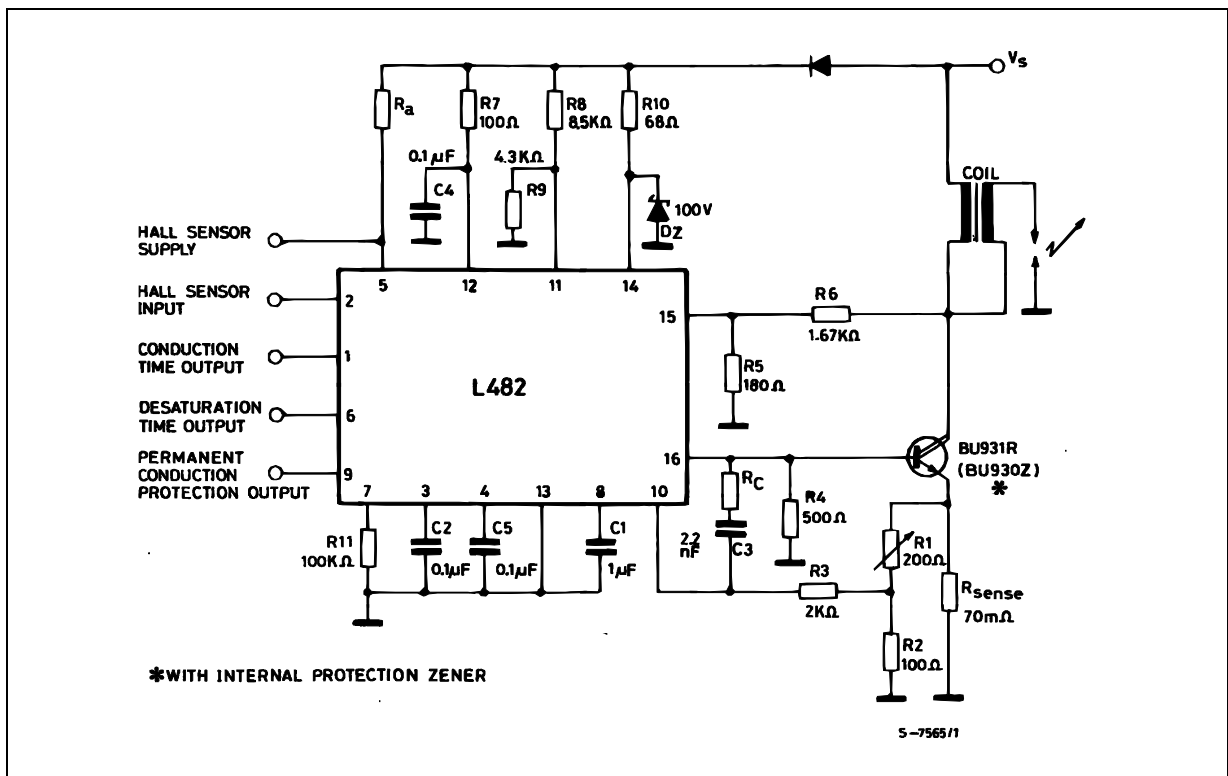
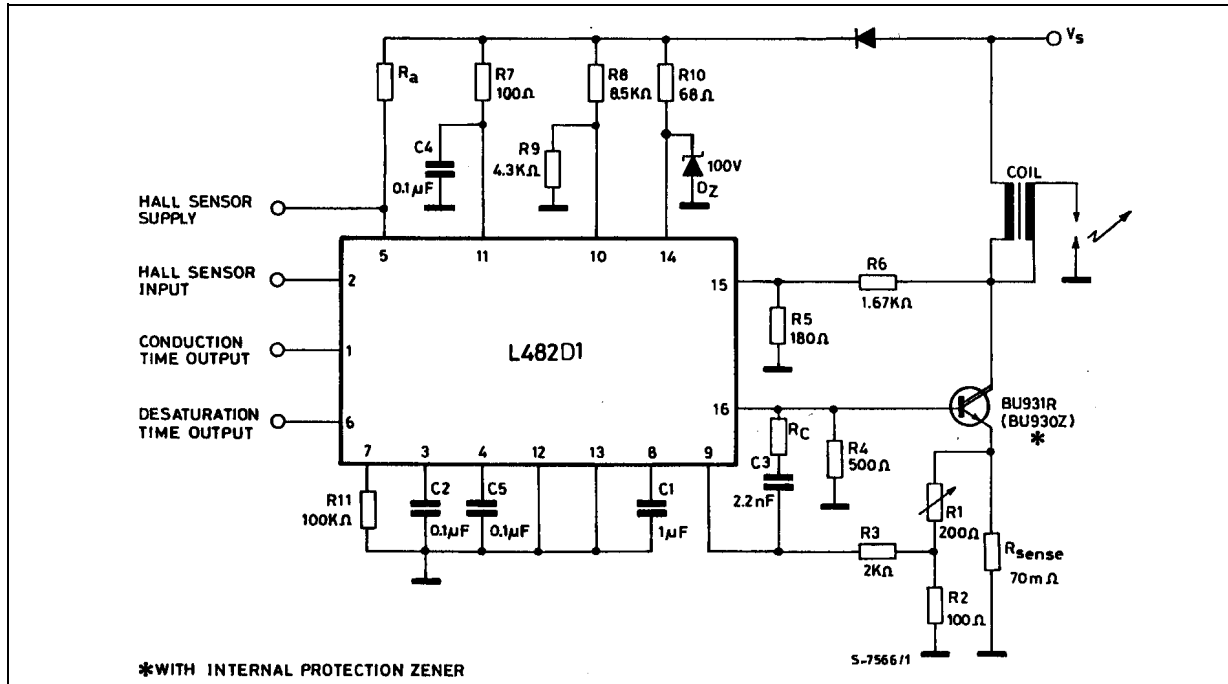

Figure 4 : Application Circuit (SO-16).



CIRCUIT OPERATION

The L482 control the conduction time (dwell) and the peak value of the primary current in the coil over the full range of operating conditions.

The coil current is limited to a predetermined level by means of a negative feedback circuit including a current sensing resistor, a comparator, the driver stage and the power switch.

The dwell control circuit maintains the output stage in its active region during current limitation. The time the output stage is in the active region (desaturation time) is sufficient to compensate for possible variations in the energy stored due to the acceleration of the motor ; moreover this time is limited to avoid excessive power dissipation.

CONTROL OF THE DWELL ANGLE (fig. 1 and 4)

The dwell angle control circuit calculates the conduction time D for the output transistor in relation to the speed of rotation, to the supply voltage and to the characteristic of the coil.

On the negative edge of the Hall-effect input signal the capacitor C₂ begins discharging with a constant current I_{3D}. When the set peak value of the coil current is reached, this capacitor charges with a constant current I_{3C} = 13.3 x I_{3D} and the coil current is

kept constant by desaturating the driver stage and the external darlington.

The capacitor C₅ starts charging on the positive edge of the Hall-effect input signal with a constant current I_{4C}.

The dwell angle, and consequently the starting point of the coil current production, is decided by the comparison between V_{C2} and V_{C5}. A positive hysteresis is added to the dwell comparator to avoid spurious effects and C₅ is rapidly discharged on the negative edge of Hall-effects input signal.

In this way the average voltage on C₂ increases if the motor speed decreases and viceversa in order to maintain constant the ratio $\frac{td}{T}$ at any motor speed.

td is kept constant (and not d = cost) to control the power dissipation and to have sufficient time to avoid low energy sparks during acceleration.

The charging time D – td depends on the coil and the voltage supply.

DESATURATION TIMES IN STATIC CONDITION-
S.In static conditions, if C₂ = C₅ as recommended and if the values of the application circuit of fig. 3, 4 are used.

$$\frac{td}{T} = \frac{1}{1 + I_{3C}/I_{3D}}$$

DESATURATION TIMES IN LOW AND HIGH FREQUENCY OPERATION. Due to the upper limit of the voltage range of pin 3, if the components of fig. 3, 4 are used, below 10Hz (300RPM for a 4 cylinder engine) the OFF time reaches its maximum value (about 50ms) and then the circuit gradually loses the control of the dwell angle because $D = T - 50\text{ms}$

Over 200Hz (6000RPM for a 4 cylinder engine) the available time for the conduction is less than 3.5ms. If the used coil is 6mH, 6A, the OFF time is reduced to zero and the circuit loses the dwell angle control.

TRANSIENT RESPONSE. The ignition system must deliver constant energy even during the condition of acceleration and deceleration of the motor below 80Hz/s. These conditions can be simulated by means of a signal generator with a linearly modulated frequency between 1Hz and 200Hz (this corresponds to a change between 30 and 6000RPM for a 4 cylinders engine).

CURRENT LIMIT. The current in the coil is monitored by measuring the I_{sense} current flowing in the sensing resistor R_s on the emitter of the external darlington. I_{sense} is given by :

$$I_{\text{sense}} = I_{\text{coil}} + I_{16}$$

When the voltage drop across R_s reaches the internal comparator threshold value the feedback loop is activated and I_{sense} kept constant (fig. 1) forcing the external darlington in the active region. In this condition :

$$I_{\text{sense}} = I_{\text{coil}}$$

When a precise peak coil current is required R_5 must be trimmed or an auxiliary resistor divider (R_1 , R_2) added :

$$I_{\text{cpeak}} (\text{A}) = \frac{V_{\text{SENS}}}{R_s} \left(\frac{R_1}{R_2} + 1 \right)$$

PROTECTION CIRCUIT

PERMANENT CONDUCTION PROTECTION

The battery voltage is applied to ignition module by means of the ignition key. In these conditions, with the motor stopped, it is necessary that there is no permanent conduction in the ignition coil irrespective of the polarity of the input signal.

The L482 incorporates a timing circuit to implement this protection ; the duration of the intervention is set by means of a capacitor C_1 at pin 8 = 1 μ F, and $R_{11} = 100\text{k}\Omega$, when the input signal is high for more than 1 s, the coil current gradually decreases down to zero to avoid spurious sparks (see fig. 2).

This timing allows normal operation of the module above 30RPM.

DARLINGTON OVERVOLTAGE LIMITATION

The darlington is protected against overvoltage by means of an external divider R_5/R_6 (pin 15) and an internal zener. This zener drives the external darlington in order to limit the collector voltage.

REVERSE BATTERY PROTECTION. Due to the presence of external impedance at pin 5, 10, 11, 14, 15, L482 is protected against reverse battery voltage.

DUMP PROTECTION.

The load dump protection withstands up to 100V with a decay time $\leq 300\text{ms}$. The intervention threshold for load dump is fixed by means of an external divider connected to pin 11 (DIP-16 package version) or to pin 10 using a Micropackage type.

NEGATIVE SPIKE PROTECTION. If correct operation is requested also during short negative spikes, the diode D_S and capacitor C_S must be used.

USE OF THE IC ELECTRONIC ADVANCE SYSTEM

When the device is digitally controlled the control unit transmits a suitable input signal to the power module, receiving in turn information that allows the control of the dwell and the on time of the final transistor.

For this reason L482 provides the following outputs :

- a time signal equal to the time in which the final Darlington is in the active region i.e. when the coil current is limited (V_{ds}) as shown in figure 1. This signal must be TTL compatible.
- a TTL compatible output from the timing circuit (V_{rs} in figure 2). This pulse, available only using the DIP-16 package version is present after the protection against cranking transients.
- a time signal equal to the time in which the final Darlington, is in "on" condition (V_{on}) i.e. when the current flows through the coil, see fig. 1.

OTHER APPLICATION INFORMATION

If the supply voltage is disconnected - or the battery wire is broken - while the current is flowing through the coil, the external diode D_1 keeps the coil current from recirculating into the device : in this way both device and darlington are protected.

DIM.	mm			inch		
	MIN.	TYP.	MAX.	MIN.	TYP.	MAX.
a1	0.51			0.020		
B	0.77		1.65	0.030		0.065
b		0.5			0.020	
b1		0.25			0.010	
D			20			0.787
E		8.5			0.335	
e		2.54			0.100	
e3		17.78			0.700	
F			7.1			0.280
I			5.1			0.201
L		3.3			0.130	
Z			1.27			0.050

OUTLINE AND MECHANICAL DATA

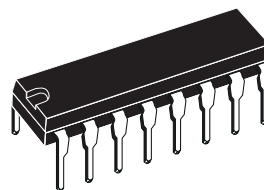

DIP16

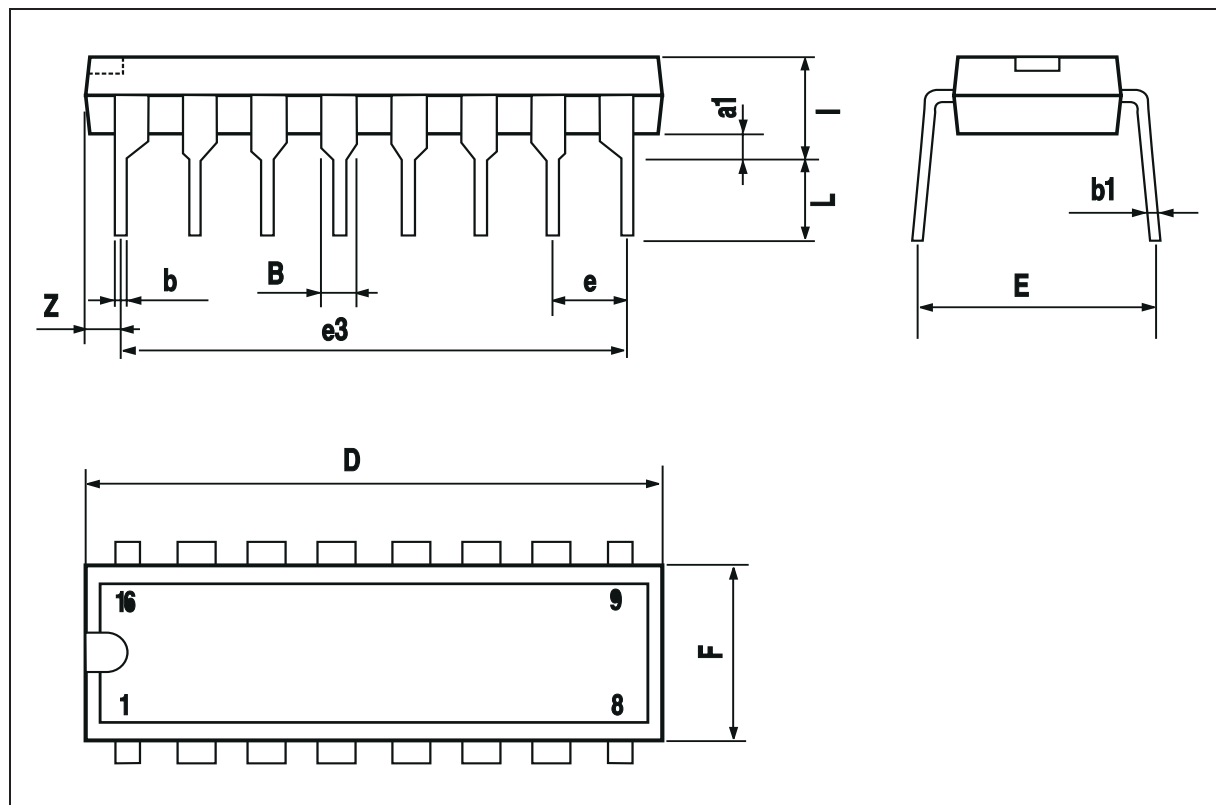

DIM.	mm			inch		
	MIN.	TYP.	MAX.	MIN.	TYP.	MAX.
A			1.75			0.069
a1	0.1		0.25	0.004		0.009
a2			1.6			0.063
b	0.35		0.46	0.014		0.018
b1	0.19		0.25	0.007		0.010
C		0.5			0.020	
c1	45° (typ.)					
D (1)	9.8		10	0.386		0.394
E	5.8		6.2	0.228		0.244
e		1.27			0.050	
e3		8.89			0.350	
F (1)	3.8		4	0.150		0.157
G	4.6		5.3	0.181		0.209
L	0.4		1.27	0.016		0.050
M			0.62			0.024
S	8°(max.)					

OUTLINE AND MECHANICAL DATA

Weight: 0.20gr

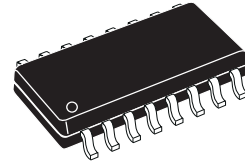

SO16 Narrow

(1) D and F do not include mold flash or protrusions. Mold flash or protrusions shall not exceed 0.15mm (.006inch).

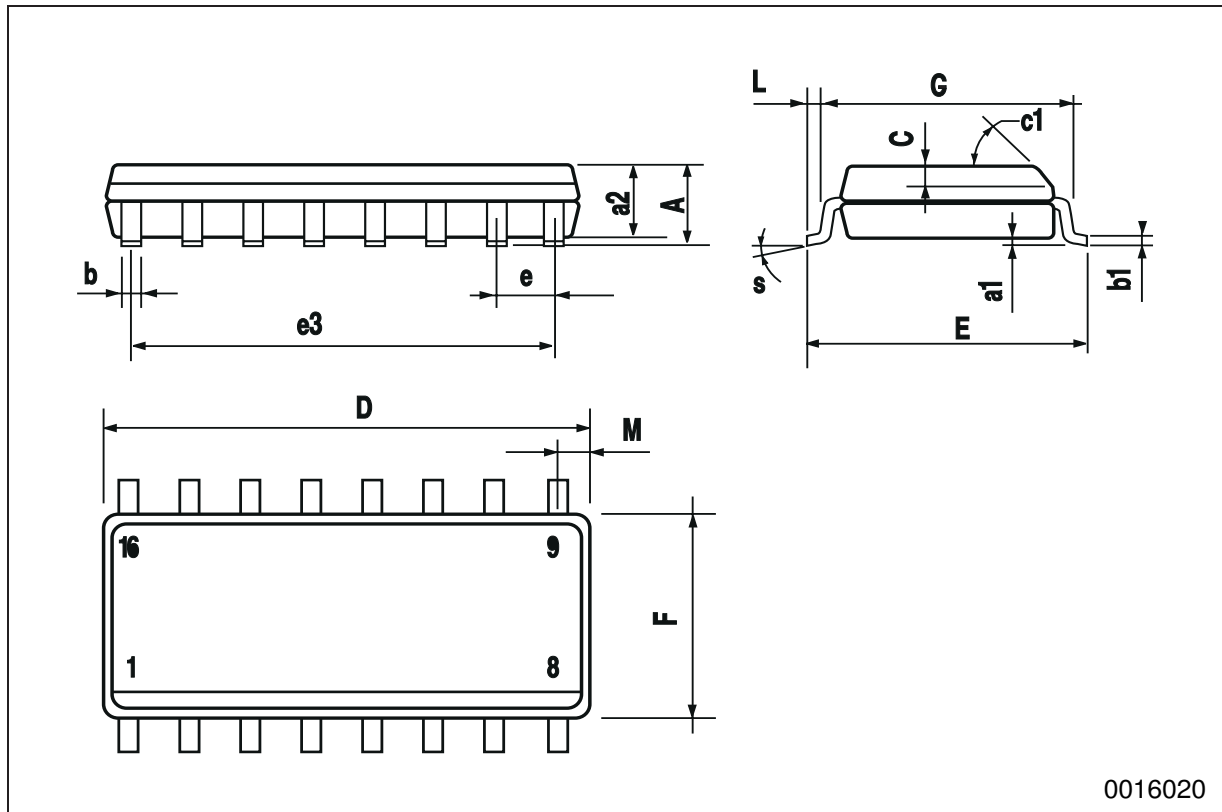

0016020

Information furnished is believed to be accurate and reliable. However, STMicroelectronics assumes no responsibility for the consequences of use of such information nor for any infringement of patents or other rights of third parties which may result from its use. No license is granted by implication or otherwise under any patent or patent rights of STMicroelectronics. Specification mentioned in this publication are subject to change without notice. This publication supersedes and replaces all information previously supplied. STMicroelectronics products are not authorized for use as critical components in life support devices or systems without express written approval of STMicroelectronics.

The ST logo is a registered trademark of STMicroelectronics
© 2003 STMicroelectronics – Printed in Italy – All Rights Reserved
STMicroelectronics GROUP OF COMPANIES

Australia - Brazil - Canada - China - Finland - France - Germany - Hong Kong - India - Israel - Italy - Japan - Malaysia - Malta - Morocco -
Singapore - Spain - Sweden - Switzerland - United Kingdom - United States.

<http://www.st.com>