



Chipsmall Limited consists of a professional team with an average of over 10 year of expertise in the distribution of electronic components. Based in Hongkong, we have already established firm and mutual-benefit business relationships with customers from,Europe,America and south Asia,supplying obsolete and hard-to-find components to meet their specific needs.

With the principle of “Quality Parts,Customers Priority,Honest Operation,and Considerate Service”,our business mainly focus on the distribution of electronic components. Line cards we deal with include Microchip,ALPS,ROHM,Xilinx,Pulse,ON,Everlight and Freescale. Main products comprise IC,Modules,Potentiometer,IC Socket,Relay,Connector.Our parts cover such applications as commercial,industrial, and automotives areas.

We are looking forward to setting up business relationship with you and hope to provide you with the best service and solution. Let us make a better world for our industry!



## Contact us

Tel: +86-755-8981 8866 Fax: +86-755-8427 6832

Email & Skype: info@chipsmall.com Web: www.chipsmall.com

Address: A1208, Overseas Decoration Building, #122 Zhenhua RD., Futian, Shenzhen, China





## MULTIPLE MULTIFUNCTION VOLTAGE REGULATOR

- FIVE REGULATED OUTPUTS
  - Vo1 5V @500mA
  - Vo2 8.3V @ 250mA
  - Vo3 7.7V to 8.5V @250mA (I<sup>2</sup>C presettable)
  - Vo4 5V to 7.3V @0.4A (I<sup>2</sup>C presettable)
  - Vo5 3.3V to 5V @500mA (I<sup>2</sup>C presettable)
  - HSDout R<sub>ON</sub> = 0.6Ω
- I<sup>2</sup>C ENABLE & OUT PRESET
- ADJUSTABLE BATTERY DETECTION CIRCUIT
- RESET OUTPUT
- BACKUP FACILITY
- LOW QUIESCENT CONSUMPTION
- HIGH RIPPLE REJECTION
- LOAD DUMP
- OVERCURRENT & SHORT CIRCUIT PROTECTORS
- THERMAL SHUTDOWN

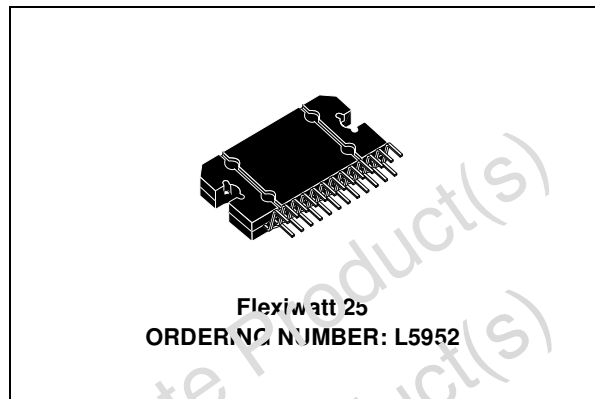

### DESCRIPTION

The L5952 is a multifunction 5 output voltage regulator plus a High Side Driver primarily developed for car radio applications.

Three outputs are enabled and set via I<sup>2</sup>C bus.

Very low stand-by current consumption is achieved to specifically comply with entertainment and automotive environments.

### PIN CONNECTION (Top View)

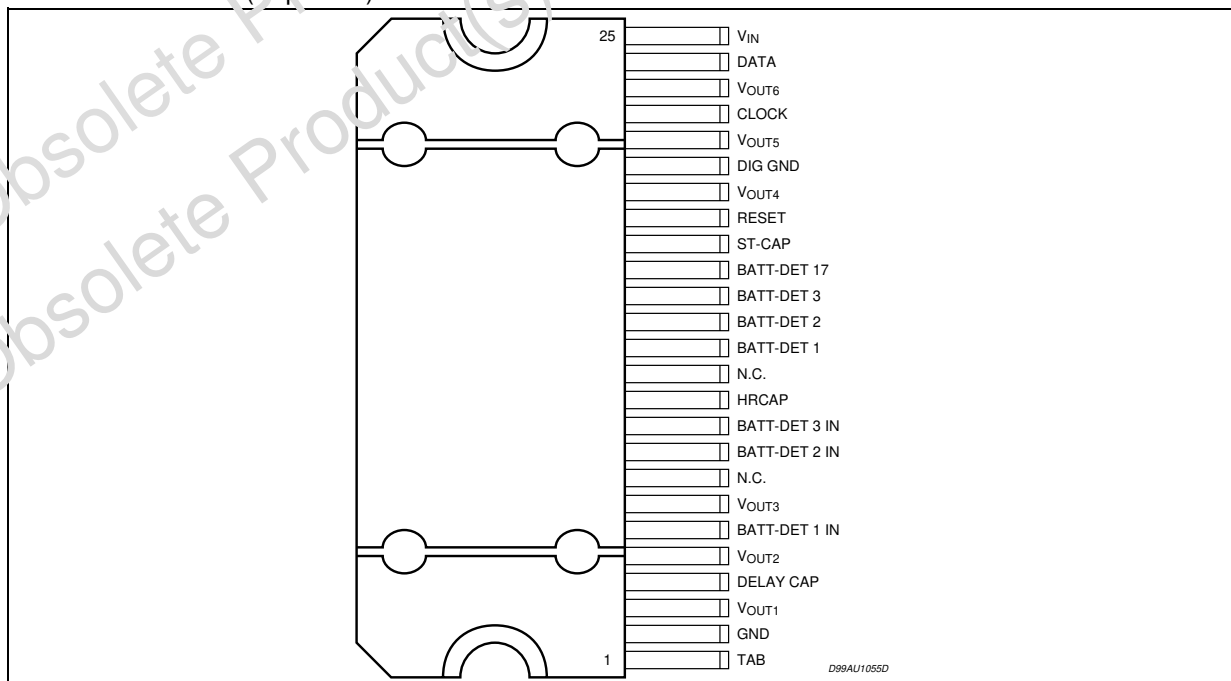

**BLOCK DIAGRAM**

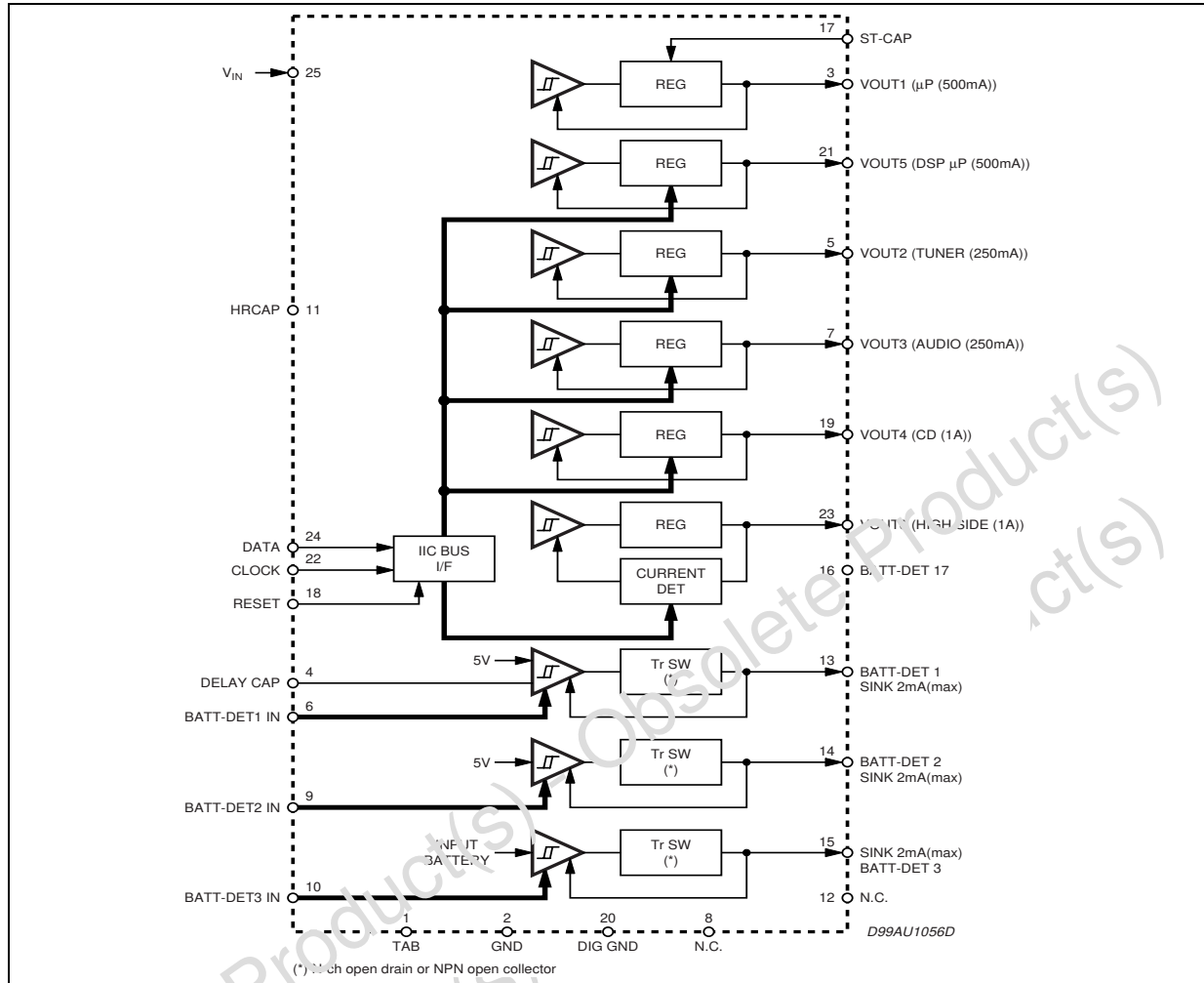

**ABSOLUTE MAXIMUM RATINGS**

| Symbol    | Parameter  | Value      | Unit        |
|-----------|--|------------|-------------|
| $V_{IN}$  | DC Supply Voltage  | -0.6 to 26 | V           |
| $V_{IN}$  | Transient Supply Overvoltage (50ms)                        | 50         | V           |
| $R_{ESR}$ | Output Capacitor Series Eq. Series Resistors Allowed Range | 0.2 to 10  | $\Omega$    |
| $T_{op}$  | Operating Temperature Range                                | -40 to 85  | $^{\circ}C$ |
| $T_{stg}$ | Storage Temperature Range                                  | -40 to 150 | $^{\circ}C$ |

**THERMAL DATA**

| Symbol           | Parameter                        | Value | Unit          |
|------------------|----------------------------------|-------|---------------|
| $R_{th\ j-case}$ | Thermal resistance junction-case | 1.3   | $^{\circ}C/W$ |

## TEST CIRCUIT

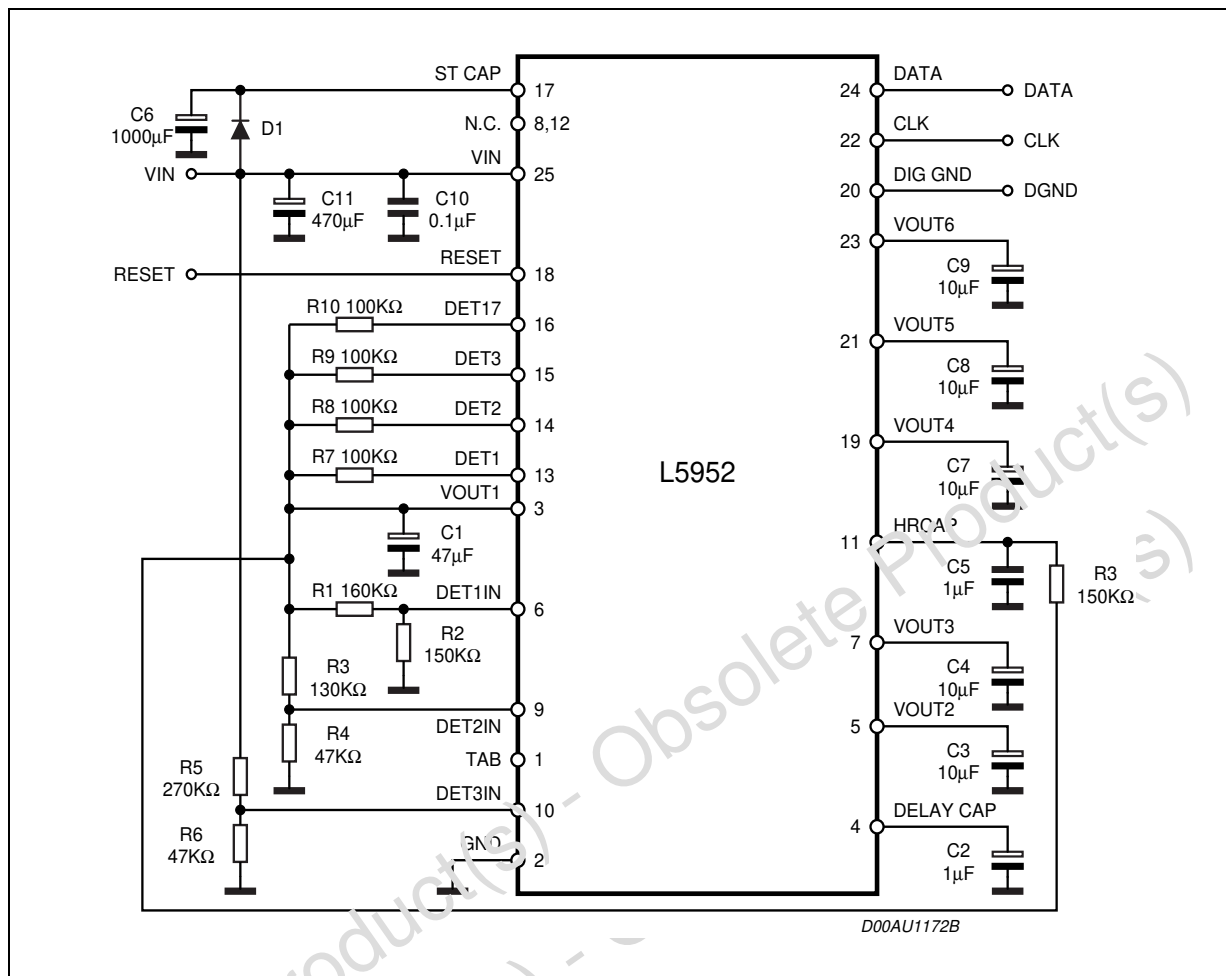

**ELECTRICAL CHARACTERISTICS** (Ref. to Test Circuit,  $V_{IN} = 14.4V$ ,  $T_{case} = 25^{\circ}C$ , unless otherwise noted).

| Symbol       | Parameter         | Test Condition  | Min | Typ | Max | Unit    |
|--------------|-------------------|---|-----|-----|-----|---------|
| <b>INPUT</b> |                   |   |     |     |     |         |
| $V_{op}$     | Operating Voltage |   | 9   |     | 16  | V       |
|              | Jump Start        | $t < 1min$ ; still in normal operation  |     |     | 27  | V       |
|              | Load Dump         | 50V, 50ms; still in normal operation at Vout1, Det 1,2,3                              |     |     | 50  | V       |
|              | Delay Reset       | $C_2 = 1\mu F$  | 2   | 3   | 4   | ms      |
|              | System Reset LO   | Vout1, Det 1,2,3,17 = active  |     |     | 1   | V       |
|              | System Reset Hi   |   | 4   |     |     | V       |
| $I_Q$        | Quiescent Current | Vout1, Det 1,2,3,17 = active<br>Not including I into R <sub>1</sub> to R <sub>6</sub> |     | 80  | 120 | $\mu A$ |
|              | Hard Reset        | $C = 1\mu F$ ; $R = 150k\Omega$   | 50  | 100 |     | ms      |

## ELECTRICAL CHARACTERISTICS (Continued)

| Symbol | Parameter | Test Condition | Min | Typ | Max | Unit |
|--------|-----------|----------------|-----|-----|-----|------|
|--------|-----------|----------------|-----|-----|-----|------|

## OUTPUTS:

Output voltage 1 ( $V_{out1}$ )

|                   |                  |   |      |      |      |    |
|-------------------|------------------|---|------|------|------|----|
| $V_{out}$         | Output Voltage   | $I_{out} < 500\text{mA}$ ; $V_{batt-up\ cap} = 9\text{ to }16\text{V}$<br>$I_{out} < 250\text{mA}$ ; $V_{batt-up\ cap} = 7\text{ to }9\text{V}$ | 4.75 | 5    | 5.25 | V  |
| $I_{max.}$        | Maximum Current  | current limiter   | 600  | 1200 |      | mA |
| $\Delta V_{load}$ | Load Regulation  | $I_{out} = 0\text{ to }500\text{mA}$  |      | 30   | 50   | mV |
| SVRR              | Ripple Rejection | 1kHz, $V_{ripple} = 2\text{Vpp}$  | 50   | 60   |      | dB |
| $V_{drop1}$       | Voltage Drop     | $I_{out} = 500\text{mA}$  |      | 1.5  | 2.5  | V  |
| $V_{drop2}$       | Voltage Drop     | $I_{out} = 250\text{mA}$  |      | 0.75 | 1.25 | V  |
| $\Delta V_{lin}$  | Line Regulation  | $I_{OUT} = 0$   |      | 0    | 50   | mV |

$V_{out1}$  is 5V regulator

Output voltage 2 ( $V_{out2}$ )

|                   |                  |  |     |     |     |    |
|-------------------|------------------|--|-----|-----|-----|----|
| $V_{out}$         | Output Voltage   | $I_{out} < 250\text{mA}$ ; $V_{in} = 9\text{ to }16\text{V}$ | 8.1 | 8.3 | 8.5 | V  |
| $I_{max.}$        | Maximum Current  | current limiter  | 300 | 450 |     | mA |
| $\Delta V_{load}$ | Load Regulation  | $I_{out} = 0\text{ to }250\text{mA}$                         |     | 20  | 50  | mV |
| SVRR              | Ripple Rejection | 1kHz, $V_{ripple} = 2\text{Vpp}$                             | 45  | 55  |     | dB |
| $V_{drop}$        | Voltage Drop     | $I_{out} = 250\text{mA}$                                     |     | 0.5 | 0.6 | V  |
| $\Delta V_{lin}$  | Line Regulation  | $I_{OUT} = 0$  |     | 0   | 50  | mV |

$V_{out2}$  has On/OFF function by I<sup>2</sup>C. Default is OFF

Output voltage 3 ( $V_{out3}$ )

|                   |                  |  |     |      |     |    |
|-------------------|------------------|--|-----|------|-----|----|
| $V_{adj}$         | Adjustable range | $I_{out} < 250\text{mA}$ ; $V_{in} = 9\text{ to }16\text{V}$ | 7.7 |      | 8.5 | V  |
| $I_{max.}$        | Maximum Current  | current limiter  | 300 |      |     | mA |
| $\Delta V_{load}$ | Load Regulation  | $I_{out} = 0$  |     | 20   | 50  | mV |
| SVRR              | Ripple Rejection | 1kHz, $V_{ripple} = 2\text{Vpp}$                             | 50  | 60   |     | dB |
| $V_{drop}$        | Voltage Drop     | $I_{out} = 250\text{mA}$                                     |     | 0.45 | 0.6 | V  |
| $\Delta V_{lin}$  | Line Regulation  | $I_{OUT} = 0$  |     | 0    | 50  | mV |

 $V_{out3}$  Voltage configuration

|  |           |   |     |     |     |   |
|--|-----------|---|-----|-----|-----|---|
|  | Setting 1 | $I_{out} < 250\text{mA}$ ; $V_{in} = 10\text{ to }16\text{V}$ | 8.2 | 8.5 | 8.8 | V |
|  | Setting 2 | $I_{out} < 250\text{mA}$ ; $V_{in} = 10\text{ to }16\text{V}$ | 8   | 8.3 | 8.6 | V |
|  | Setting 3 | $I_{out} < 250\text{mA}$ ; $V_{in} = 10\text{ to }16\text{V}$ | 7.8 | 8.1 | 8.4 | V |
|  | Setting 4 | $I_{out} < 250\text{mA}$ ; $V_{in} = 9\text{ to }16\text{V}$  | 7.6 | 7.9 | 8.2 | V |
|  | Setting 5 | $I_{out} < 250\text{mA}$ ; $V_{in} = 9\text{ to }16\text{V}$  | 7.4 | 7.7 | 8.0 | V |

Select one of above settings as well as ON/OFF control by I<sup>2</sup>C. Default is OFF.

## ELECTRICAL CHARACTERISTICS (Continued)

| Symbol | Parameter | Test Condition | Min | Typ | Max | Unit |
|--------|-----------|----------------|-----|-----|-----|------|
|--------|-----------|----------------|-----|-----|-----|------|

**Output 4: (V<sub>out4</sub>)**

|                    |                  |                                  |     |     |      |    |
|--------------------|------------------|----------------------------------|-----|-----|------|----|
| V <sub>adj</sub>   | Adjustable range | I <sub>out</sub> = 400mA         | 5   |     | 7.3  | V  |
| I <sub>max</sub>   | Max. Current     | Current limiter                  | 1.2 | 2.4 |      | A  |
| SVRR               | Ripple rejection | 1kHz, V <sub>ripple</sub> = 2Vpp | 50  | 60  |      | dB |
| V <sub>drop</sub>  | Voltage Drop     | I <sub>out</sub> = 400mA         |     | 0.6 | 0.75 | V  |
| ΔV <sub>load</sub> | Load Regulation  | I <sub>out</sub> = 0 to 400mA    |     | 20  | 50   | mV |
| ΔV <sub>lin</sub>  | Line Regulation  | I <sub>OUT</sub> = 0             |     | 0   | 50   | mV |

**V<sub>out4</sub> Voltage configuration**

|  |           |  |      |     |      |   |
|--|-----------|--|------|-----|------|---|
|  | Setting 1 | I <sub>out</sub> < 400mA; V <sub>in</sub> = 9 to 16V | 7    | 7.3 | 7.6  | V |
|  | Setting 2 |  | 6.7  | 7   | 7.3  | V |
|  | Setting 3 |  | 6.3  | 6.6 | 6.9  | V |
|  | Setting 4 |  | 6    | 6.3 | 6.6  | V |
|  | Setting 5 |  | 5.7  | 6   | 6.3  | V |
|  | Setting 6 |  | 5.3  | 5.5 | 5.7  | V |
|  | Setting 7 |  | 4.75 | 5   | 5.25 | V |

Select one of above settings as well as ON/OFF control by I<sup>2</sup>C. Default is OFF

**Output 5 (V<sub>out5</sub>)**

|                    |                  |                                  |     |      |     |    |
|--------------------|------------------|----------------------------------|-----|------|-----|----|
| V <sub>adj</sub>   | Adjustable range | I <sub>out</sub> < 500mA         | 3.3 |      | 5   | V  |
| I <sub>max</sub>   | Max. Current     | Current limiter                  | 600 | 1000 |     | mA |
| ΔV <sub>load</sub> | Load Regulation  | I <sub>out</sub> = 0 to 500mA    |     | 30   | 50  | mV |
| SVRR               | Ripple Rejection | 1kHz, V <sub>ripple</sub> = 2Vpp | 50  | 60   |     | dB |
| V <sub>drop</sub>  | Voltage Drop     | I <sub>out</sub> = 500mA         |     | 2.4  | 3.6 | V  |
| ΔV <sub>lin</sub>  | Line Regulation  | I <sub>OUT</sub> = 0             |     | 0    | 50  | mV |

**V<sub>out5</sub> Voltage configuration**

|  |           |  |      |     |      |   |
|--|-----------|--|------|-----|------|---|
|  | Setting 1 | I <sub>out</sub> < 500mA; V <sub>in</sub> = 9 to 16V | 3.1  | 3.3 | 3.5  | V |
|  | Setting 2 |  | 4.75 | 5.0 | 5.25 | V |

Select one of above settings as well as ON/OFF control by I<sup>2</sup>C. Default is OFF

**Output 6 (V<sub>out6</sub>)**

|                  |                |  |     |  |      |   |
|------------------|----------------|--|-----|--|------|---|
| V <sub>out</sub> | Output Voltage | I <sub>out</sub> < 800mA; V <sub>in</sub> = 9 to 16V | 8.4 |  | 15.4 | V |
|------------------|----------------|--|-----|--|------|---|

## ELECTRICAL CHARACTERISTICS (Continued)

| Symbol     | Parameter       | Test Condition    | Min | Typ  | Max | Unit |
|------------|-----------------|-------------------|-----|------|-----|------|
| $I_{max}$  | Maximum Current | Current limiter   | 1.2 |      |     | A    |
| $V_{drop}$ | Dropout Voltage | $I_{out} < 800mA$ |     | 0.45 | 0.6 | V    |

$V_{out6}$  has On/OFF function by I<sup>2</sup>C. Default is OFF

## Battery Detection1 (Det1)

|           |   |                    |     |      |     |   |
|-----------|---|--------------------|-----|------|-----|---|
|           | Vthreshold                              | ST-CAP rising      | 7   | 7.3  | 8   | V |
| $V_{adj}$ | Adjustable Range Th2 with ext. resistor | $V_{out1}$ falling | 2.4 | 2.55 | 2.7 | V |
| $V_{OL}$  | L Output Voltage                        | $I_{out} = 2mA$    |     | 0.5  | 0.8 | V |

Note: 1 $\mu$ F is recommended for delay Cap (min: 100nF)

## Battery Detection2 (Det2)

|           |                                     |                 |      |      |     |    |
|-----------|-------------------------------------|-----------------|------|------|-----|----|
| $V_{adj}$ | Adjustable Range with ext. resistor |                 | 4.45 | 4.65 | 4.8 | V  |
|           | Hysteresis                          |                 | 30   | 60   | 120 | mV |
| $V_{OL}$  | L Output Voltage                    | $I_{out} = 2mA$ |      | 0.5  | 0.8 | V  |

## Battery Detection3 (Det3)

|           |   |                 |      |      |      |    |
|-----------|---|-----------------|------|------|------|----|
| $V_{adj}$ | Adjustable Range with external resistor |                 | 7.25 | 8.35 | 8.55 | V  |
|           | Hysteresis                              |                 | 50   | 100  | 150  | mV |
| $V_{OL}$  | L Output Voltage                        | $I_{out} = 2mA$ |      | 0.5  | 0.8  | V  |

## Battery Detection17 (Det17)

|          |                  |                 |      |     |     |   |
|----------|------------------|-----------------|------|-----|-----|---|
|          | Vthreshold       | ST-CAP          | 16.5 | 17  | 18  | V |
| $V_{OL}$ | L Output Voltage | $I_{out} = 2mA$ |      | 0.5 | 0.8 | V |

I<sup>2</sup>C BUS

|          |                    |  |   |  |     |     |
|----------|--------------------|--|---|--|-----|-----|
| $F_{ck}$ | Clock Frequency    |  |   |  | 400 | kHz |
| $t_R$    | Rising Time        |  |   |  | 300 | ns  |
| $t_F$    | Falling Time       |  |   |  | 300 | ns  |
| $V_{IL}$ | Low Input Voltage  |  |   |  | 1   | V   |
| $V_{IH}$ | High Input Voltage |  | 3 |  |     | V   |

## Hard Reset

|          |                    |  |   |  |   |   |
|----------|--------------------|--|---|--|---|---|
| $V_{IL}$ | Low Input Voltage  |  |   |  | 2 | V |
| $V_{IH}$ | High Input Voltage |  | 3 |  |   | V |

Figure 1. Comparator Part

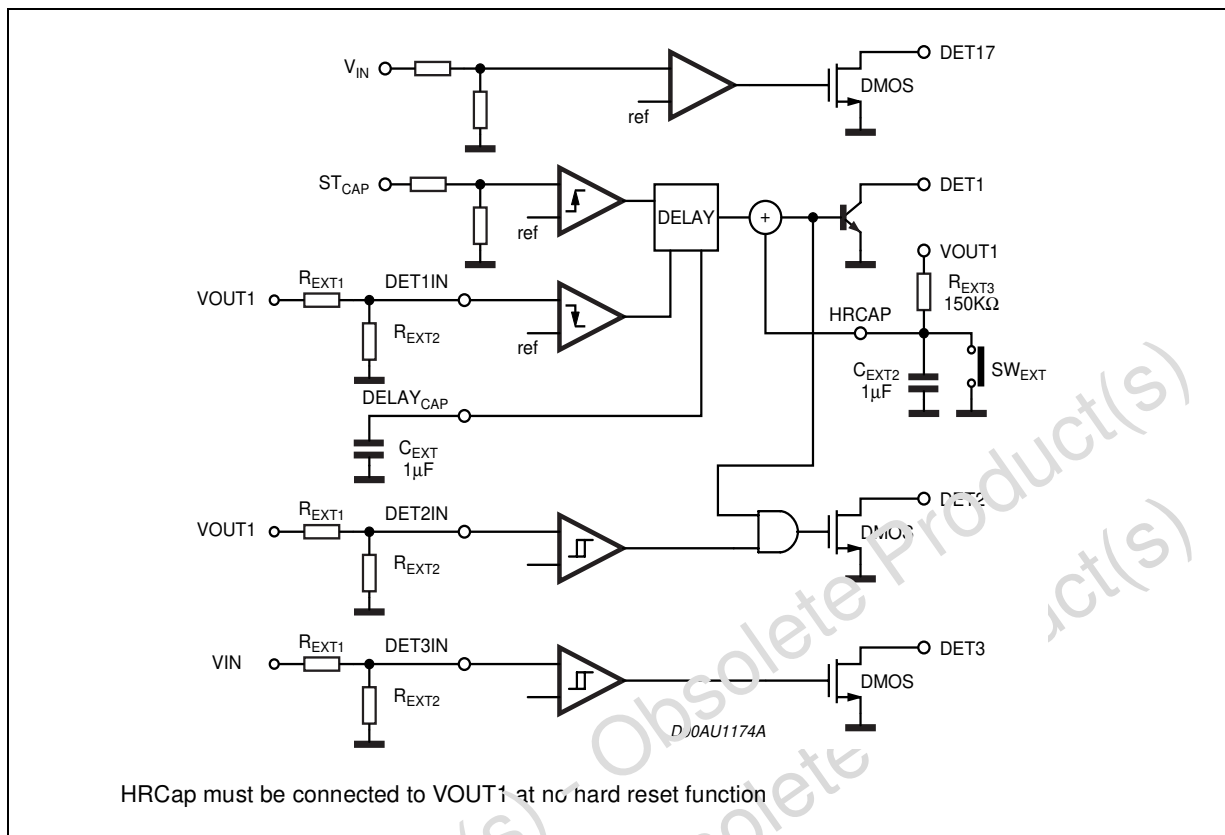
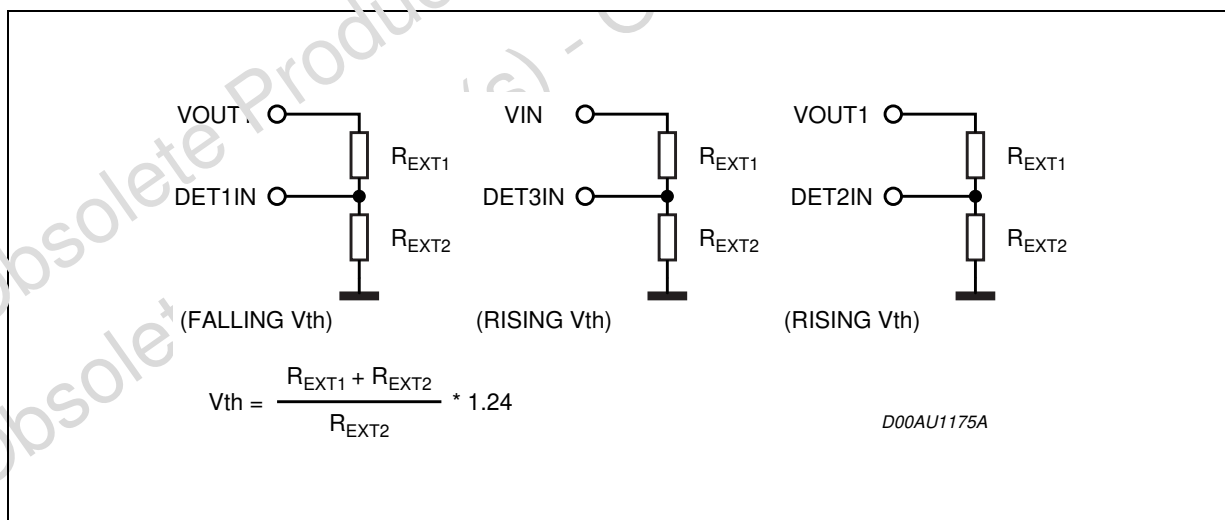

Figure 2. Reset Function



DET1,2 Delay Time:  $T = 3000 \times C <sec>$

Hard Reset Time:  $T = -CR \ln 0.7 <sec>$



Figure 3. Timing Chart (typical values)

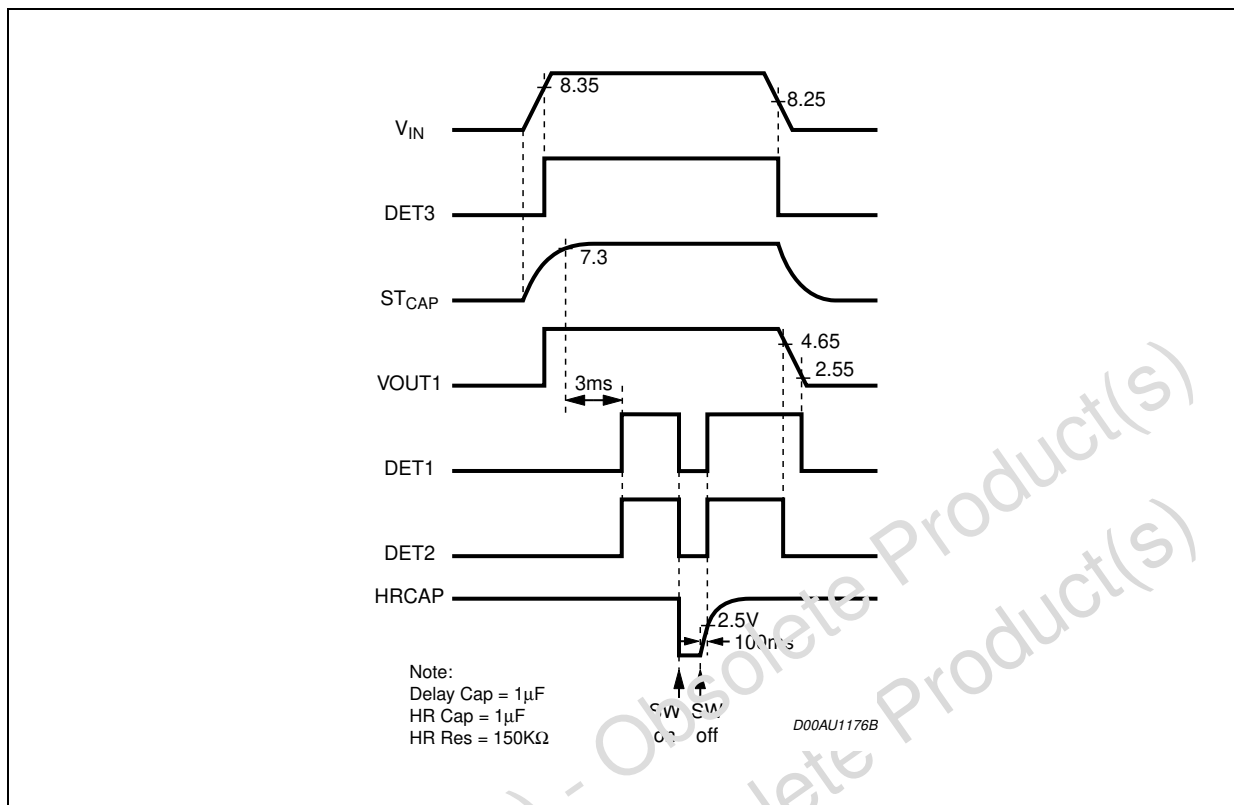

**SOFTWARE SPECIFICATION**

**Interface Protocol**

The interface protocol comprises:

- A start condition (S)
- A chip address byte, (LSB bit = 0 for write mode)
- A subaddress byte.
- A sequence of data (N-bytes + acknowledge)
- A stop condition (P)

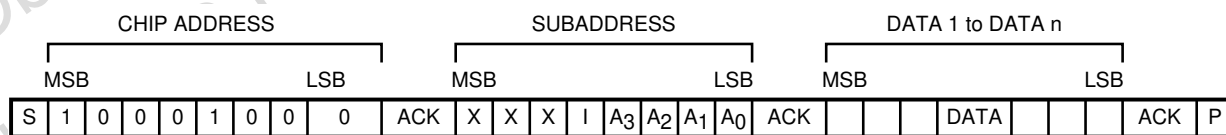

ACK = Acknowledge

S = Start

P = Stop

I = Auto Increment

X = Not used

MAX CLOCK SPEED 500kbits/s

CHIP ADDRESS = 10001000 (88 Hex)

**AUTO INCREMENT**

If bit I in the subaddress byte is set to "1", the autoincrement of the subaddress is enabled, if bit I = 0 no auto-increment.

**SUBADDRESS**

| MSB |   |   |   | LSB            |                |                |                | FUNCTION |
|-----|---|---|---|----------------|----------------|----------------|----------------|----------|
| 0   | 0 | 0 | I | A <sub>3</sub> | A <sub>2</sub> | A <sub>1</sub> | A <sub>0</sub> |          |
|     |   |   |   | 0              | 0              | 0              | 0              | OUT 2    |
|     |   |   |   | 0              | 0              | 0              | 1              | OUT 3    |
|     |   |   |   | 0              | 0              | 1              | 0              | OUT 4    |
|     |   |   |   | 0              | 0              | 1              | 1              | OUT 5    |
|     |   |   |   | 0              | 1              | 0              | 0              | OUT 6    |

**DATA BYTE SPECIFICATION****OUT 2**

| MSB            |                |                |                |                |                |                | LSB            | FUNCTION |
|----------------|----------------|----------------|----------------|----------------|----------------|----------------|----------------|----------|
| D <sub>7</sub> | D <sub>6</sub> | D <sub>5</sub> | D <sub>4</sub> | D <sub>3</sub> | D <sub>2</sub> | D <sub>1</sub> | D <sub>0</sub> |          |
|                |                |                |                |                |                |                | 0              | OFF      |
|                |                |                |                |                |                |                | 1              | ON       |

**OUT 3**

| MSB            |                |                |                |                |                |                | LSB            | FUNCTION         |
|----------------|----------------|----------------|----------------|----------------|----------------|----------------|----------------|------------------|
| D <sub>7</sub> | D <sub>6</sub> | D <sub>5</sub> | D <sub>4</sub> | D <sub>3</sub> | D <sub>2</sub> | D <sub>1</sub> | D <sub>0</sub> |                  |
|                |                |                |                |                |                |                | 0              | OFF              |
|                |                |                |                |                |                |                | 1              | ON               |
|                |                |                |                | 0              | 0              | 0              |                | OUT VOLTAGE 8.5V |
|                |                |                |                | 0              | 0              | 1              |                | OUT VOLTAGE 8.3V |
|                |                |                |                | 0              | 1              | 0              |                | OUT VOLTAGE 8.1V |
|                |                |                |                | 0              | 1              | 1              |                | OUT VOLTAGE 7.9V |
|                |                |                |                | 1              | X              | X              |                | OUT VOLTAGE 7.7V |

X = don't care

## OUT 4

| MSB            |                |                |                |                |                |                | LSB            | FUNCTION         |
|----------------|----------------|----------------|----------------|----------------|----------------|----------------|----------------|------------------|
| D <sub>7</sub> | D <sub>6</sub> | D <sub>5</sub> | D <sub>4</sub> | D <sub>3</sub> | D <sub>2</sub> | D <sub>1</sub> | D <sub>0</sub> |                  |
|                |                |                |                |                |                |                | <u>0</u>       | OFF              |
|                |                |                |                |                |                |                | 1              | ON               |
|                |                |                |                | 0              | 0              | 0              |                | OUT VOLTAGE 7.3V |
|                |                |                |                | 0              | 0              | 1              |                | OUT VOLTAGE 7.0V |
|                |                |                |                | 0              | 1              | 0              |                | OUT VOLTAGE 6.6V |
|                |                |                |                | 0              | 1              | 1              |                | OUT VOLTAGE 6.3V |
|                |                |                |                | 1              | 0              | 0              |                | OUT VOLTAGE 6.0V |
|                |                |                |                | 1              | 0              | 1              |                | OUT VOLTAGE 5.5V |
|                |                |                |                | 1              | 1              | X              |                | OUT VOLTAGE 5.0V |

## OUT 5

| MSB            |                |                |                |                |                |                | LSB            | FUNCTION         |
|----------------|----------------|----------------|----------------|----------------|----------------|----------------|----------------|------------------|
| D <sub>7</sub> | D <sub>6</sub> | D <sub>5</sub> | D <sub>4</sub> | D <sub>3</sub> | D <sub>2</sub> | D <sub>1</sub> | D <sub>0</sub> |                  |
|                |                |                |                |                |                |                | <u>0</u>       | OFF              |
|                |                |                |                |                |                |                | 1              | ON               |
|                |                |                |                |                |                | 0              |                | OUT VOLTAGE 3.3V |
|                |                |                |                |                |                | 1              |                | OUT VOLTAGE 5.0V |

## OUT 6

| MSB            |                |                |                |                |                |                | LSB            | FUNCTION   |
|----------------|----------------|----------------|----------------|----------------|----------------|----------------|----------------|------------|
| D <sub>7</sub> | D <sub>6</sub> | D <sub>5</sub> | D <sub>4</sub> | D <sub>3</sub> | D <sub>2</sub> | D <sub>1</sub> | D <sub>0</sub> |            |
|                |                |                |                |                | 0              | 0              | 0              | <u>OFF</u> |
|                |                |                |                |                | 0              | 0              | 1              | ON         |

Note: Default setting indicated with underline.

**EXAMPLES**

< Example 1 - no autoincrement mode - >  
 power on  $V_{in}$  = ON All output OFF (at RESET = "L")  
 release reset RESET = "H". Send sequence:

**Initial Set**start I<sup>2</sup>C

```
1000 1000 Chip address
0000 0001 OUT3 subaddress
0000 0010 OUT3 data (8.3V, OFF)
```

stop I<sup>2</sup>Cstart I<sup>2</sup>C

```
1000 1000 Chip address
0000 0010 OUT4 subaddress
0000 0010 OUT4 data (7.0V, OFF)
```

stop I<sup>2</sup>Cstart I<sup>2</sup>C

```
1000 1000 Chip address
0000 0011 OUT5 subaddress
0000 0000 OUT5 data (3.3V, OFF)
```

stop I<sup>2</sup>C**Set Turn-On**start I<sup>2</sup>C

```
1000 1000 Chip address
0000 0000 OUT2 subaddress
0000 0001 OUT2 data (CN)
```

stop I<sup>2</sup>Cstart I<sup>2</sup>C

```
1000 1000 Chip address
0000 0001 OUT3 subaddress
0000 0011 OUT3 data (8.3V, ON)
```

stop I<sup>2</sup>Cstart I<sup>2</sup>C

```
1000 1000 Chip address
0000 0010 OUT4 subaddress
0000 0011 OUT4 data (7.0V, ON)
```

stop I<sup>2</sup>Cstart I<sup>2</sup>C

```
1000 1000 Chip address
0000 0011 OUT5 subaddress
0000 0001 OUT5 data (3.3V, ON)
```

stop I<sup>2</sup>Cstart I<sup>2</sup>C

```
1000 1000 Chip address
0000 0100 OUT6 subaddress
0000 0001 OUT6 data (ON)
```

stop I<sup>2</sup>C

**EXAMPLES**

< Example 1 - no autoincrement mode - >

power on  $V_{in}$  = ON All output OFF (at RESET = "L")

release reset RESET = "H". Send sequence:

**Initial Set**

start I<sup>2</sup>C

```

1000 1000 Chip address
0000 0001 OUT3 subaddress
0000 0010 OUT3 data (8.3V, OFF)
0000 0010 OUT4 subaddress
0000 0010 OUT4 data (7.0V, OFF)
0000 0011 OUT5 subaddress
0000 0000 OUT5 data (3.3V, OFF)

```

stop I<sup>2</sup>C

**Set Turn-On**

start I<sup>2</sup>C

```

1000 1000 Chip address
0000 0000 OUT2 subaddress
0000 0001 OUT2 data (ON)
0000 0001 OUT3 subaddress
0000 0011 OUT3 data (8.3V, ON)
0000 0010 OUT4 subaddress
0000 0011 OUT4 data (7.0V, ON)
0000 0011 OUT5 subaddress
0000 0001 OUT5 data (3.3V, ON)
0000 0100 OUT6 subaddress
0000 0001 OUT6 data (CN)

```

stop I<sup>2</sup>C

< Example 2A - autoincrement mode - >

power on  $V_{in}$  = ON All output OFF (at RESET = "L")

release reset RESET = "H"

start I<sup>2</sup>C

```

initial set 1000 1000 Chip address
0001 0001 OUT3 subaddress, autoincrement ON
0000 0010 OUT3 data (8.3V, OFF)
0000 0010 OUT4 data (7.0V, OFF)
0000 0000 OUT5 data (3.3V, OFF)

```

stop I<sup>2</sup>C

start I<sup>2</sup>C

```

set turn-on 1000 1000 Chip address
0001 0000 OUT2 subaddress, autoincrement ON
0000 0001 OUT2 data (ON)
0000 0011 OUT3 data (8.3V, ON)
0000 0011 OUT4 data (7.0V, ON)
0000 0001 OUT5 data (3.3V, ON)
0000 0001 OUT6 data (ON)

```

stop I<sup>2</sup>C

Before turning on (set turn on procedure), the output voltage should be fixed, as it is done in the initial set procedure. Do not change the bits of "turn on" and "output voltage" at the same time, otherwise the correct output

voltage may not be present.

Note - example 1 & 2 don't use the OUT2 and OUT6 bytes in the initial set procedure, since these two bytes are not related to the setting of output voltages

< Example 2B - autoincrement mode - >

power on  $V_{in}$  = ON All output OFF (at RESET = "L")

release reset RESET = "H"

start I<sup>2</sup>C

```
initial set  1000 1000  Chip address
             0001 0001  OUT3 subaddress, autoincrement ON
             0000 0010  OUT3 data (8.3V, OFF)
             0000 0010  OUT4 data (7.0V, OFF)
             0000 0000  OUT5 data (3.3V, OFF)
```

stop I<sup>2</sup>C

start I<sup>2</sup>C

```
set turn-on 1000 1000  Chip address
             0001 0010  OUT4 subaddress, autoincrement ON
             0000 0011  OUT4 data (7.0V, ON)
             0000 0001  OUT5 data (3.3V, ON)
             0000 0001  OUT6 data (ON)
             0000 0001  OUT2 data (ON)
             0000 0011  OUT3 data (8.3V, ON)
```

stop I<sup>2</sup>C

The autoincrement implements a counter by 5, this means that during autoincrement the next date after out 6 byte will be OUT2 date byte.

In the example are refreshed in sequence the bytes: OUT4 - OUT5 - OUT6 - OUT2 - OUT3

| DIM.   | mm    |       |            | inch  |       |       |
|--------|-------|-------|------------|-------|-------|-------|
|        | MIN.  | TYP.  | MAX.       | MIN.  | TYP.  | MAX.  |
| A      | 4.45  | 4.50  | 4.65       | 0.175 | 0.177 | 0.183 |
| B      | 1.80  | 1.90  | 2.00       | 0.070 | 0.074 | 0.079 |
| C      |       | 1.40  |            |       | 0.055 |       |
| D      | 0.75  | 0.90  | 1.05       | 0.029 | 0.035 | 0.041 |
| E      | 0.37  | 0.39  | 0.42       | 0.014 | 0.015 | 0.016 |
| F (1)  |       |       | 0.57       |       |       | 0.022 |
| G      | 0.80  | 1.00  | 1.20       | 0.031 | 0.040 | 0.047 |
| G1     | 23.75 | 24.00 | 24.25      | 0.935 | 0.945 | 0.955 |
| H (2)  | 28.90 | 29.23 | 29.30      | 1.139 | 1.150 | 1.153 |
| H1     |       | 17.00 |            |       | 0.669 |       |
| H2     |       | 12.80 |            |       | 0.503 |       |
| H3     |       | 0.80  |            |       | 0.031 |       |
| L (2)  | 22.07 | 22.47 | 22.87      | 0.869 | 0.884 | 0.904 |
| L1     | 18.57 | 18.97 | 19.37      | 0.731 | 0.747 | 0.762 |
| L2 (2) | 15.50 | 15.70 | 15.90      | 0.610 | 0.618 | 0.626 |
| L3     | 7.70  | 7.85  | 7.95       | 0.303 | 0.309 | 0.313 |
| L4     |       | 5     |            |       | 0.197 |       |
| L5     |       | 3.5   |            |       | 0.138 |       |
| M      | 3.70  | 4.00  | 4.30       | 0.145 | 0.157 | 0.169 |
| M1     | 3.60  | 4.00  | 4.40       | 0.142 | 0.157 | 0.173 |
| N      |       | 2.20  |            |       | 0.086 |       |
| O      |       | 2     |            |       | 0.079 |       |
| R      |       | 1.70  |            |       | 0.067 |       |
| R1     |       | 0.5   |            |       | 0.02  |       |
| R2     |       | 0.3   |            |       | 0.12  |       |
| R3     |       | 1.25  |            |       | 0.049 |       |
| R4     |       | 0.50  |            |       | 0.019 |       |
| V      |       |       | 5° (T p.)  |       |       |       |
| V1     |       |       | 3° (Typ.)  |       |       |       |
| V2     |       |       | 20° (Typ.) |       |       |       |
| V3     |       |       | 45° (Typ.) |       |       |       |

(1): dam-bar protusion not included  
 (2): molding protusion included

## OUTLINE AND MECHANICAL DATA

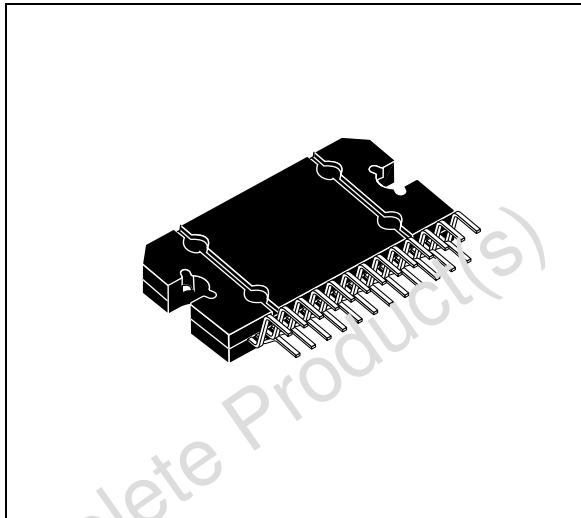

**Flexiwatt25 (vertical)**

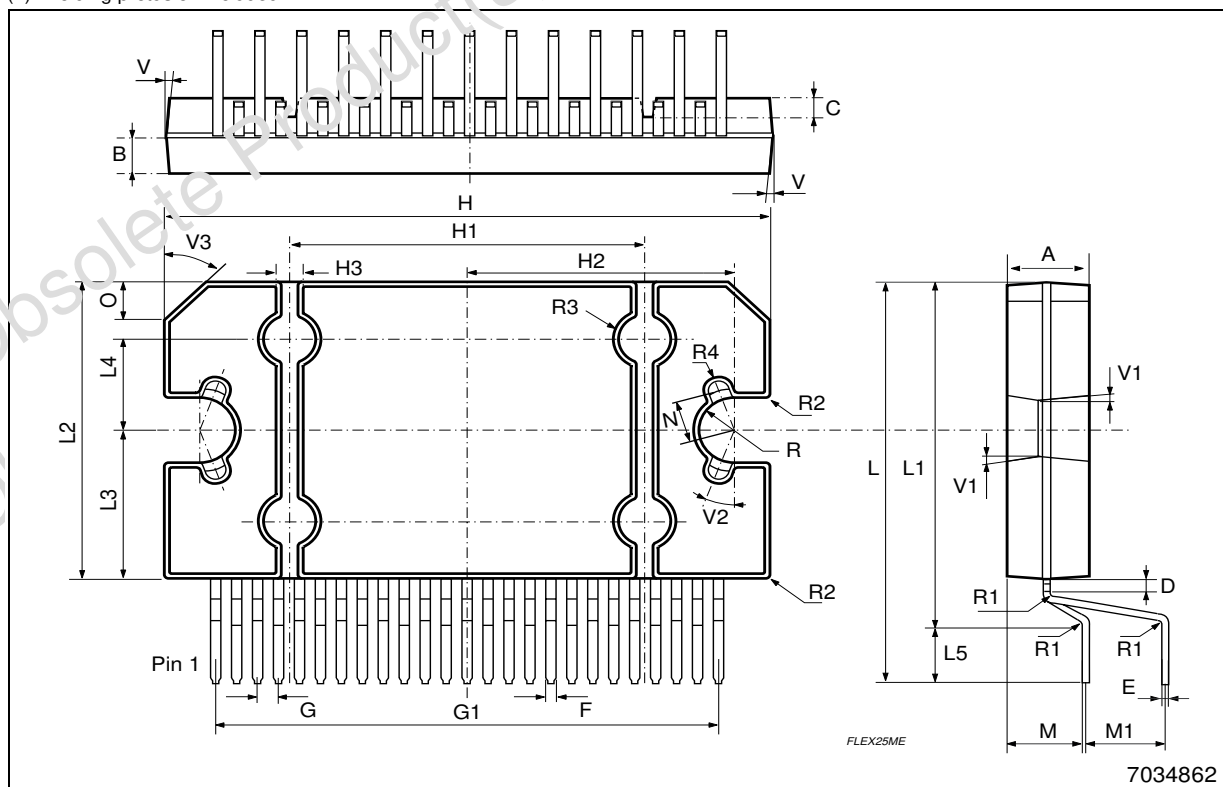

Information furnished is believed to be accurate and reliable. However, STMicroelectronics assumes no responsibility for the consequences of use of such information nor for any infringement of patents or other rights of third parties which may result from its use. No license is granted by implication or otherwise under any patent or patent rights of STMicroelectronics. Specifications mentioned in this publication are subject to change without notice. This publication supersedes and replaces all information previously supplied. STMicroelectronics products are not authorized for use as critical components in life support devices or systems without express written approval of STMicroelectronics.

The ST logo is a registered trademark of STMicroelectronics.  
All other names are the property of their respective owners

© 2003 STMicroelectronics - All rights reserved

**STMicroelectronics GROUP OF COMPANIES**

Australia - Belgium - Brazil - Canada - China - Czech Republic - Finland - France - Germany - Hong Kong - India - Israel - Italy - Japan -  
Malaysia - Malta - Morocco - Singapore - Spain - Sweden - Switzerland - United Kingdom - United States

[www.st.com](http://www.st.com)

