



Chipsmall Limited consists of a professional team with an average of over 10 year of expertise in the distribution of electronic components. Based in Hongkong, we have already established firm and mutual-benefit business relationships with customers from,Europe,America and south Asia,supplying obsolete and hard-to-find components to meet their specific needs.

With the principle of “Quality Parts,Customers Priority,Honest Operation,and Considerate Service”,our business mainly focus on the distribution of electronic components. Line cards we deal with include Microchip,ALPS,ROHM,Xilinx,Pulse,ON,Everlight and Freescale. Main products comprise IC,Modules,Potentiometer,IC Socket,Relay,Connector.Our parts cover such applications as commercial,industrial, and automotives areas.

We are looking forward to setting up business relationship with you and hope to provide you with the best service and solution. Let us make a better world for our industry!



Contact us

Tel: +86-755-8981 8866 Fax: +86-755-8427 6832

Email & Skype: info@chipsmall.com Web: www.chipsmall.com

Address: A1208, Overseas Decoration Building, #122 Zhenhua RD., Futian, Shenzhen, China



Multiple multifunction voltage regulator for car radio

Features

- 5 regulators:
 - 10 V (350 mA)
 - 8.5 V (175 mA)
 - 5 V (350 mA)
 - 5 V (250 mA)
 - 8 V/10 V (1 A)
- All regulators are low dropout
- 3 high side drivers:
 - 2 A (HSD1)
 - 0.45 A (HSD2 and HSD3)
- No external charge pump capacitors are required
- Standby mode controlled by 3 input pins:
 - Enable for Reg2 and Reg3
 - I²C bus for Reg1, Reg4, Reg5, Hsd1, Hsd2, Hsd3
- Individual thermal shutdown
- Independent current limiting
- Short circuit protection
- Load dump protection and overvoltage shutdown
- ESD protected

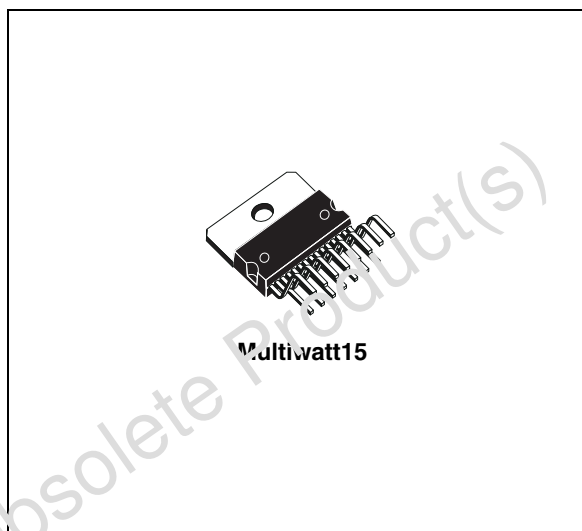

Description

The L5954 is an integration of three high side drivers and five regulators developed to provide the power for an audio system.

The outputs of the IC are controlled via the I²C bus and the Enable input.

External protection must be provided for reverse battery protection.

Table 1. Device summary

Order code	Package	Packing
L5954	Multiwatt15	Tube

Contents

1	Block and pins connection diagrams	5
2	Electrical specifications	6
2.1	Absolute maximum ratings	6
2.2	Thermal data	6
2.3	Electrical characteristics	6
3	Functional description	10
3.1	Protection	10
3.1.1	Thermal shutdown	10
3.1.2	Current limiting	10
3.1.3	Short circuit	10
3.1.4	Overvoltage	11
3.1.5	Write mode	11
3.1.6	Chip address byte	12
3.1.7	Data byte	12
4	Package information	13
5	Revision history	14

List of tables

Table 1.	Device summary	1
Table 2.	Absolute maximum ratings	6
Table 3.	Thermal data	6
Table 4.	Electrical characteristics	6
Table 5.	Document revision history	14

Obsolete Product(s) - Obsolete Product(s)

List of figures

Figure 1.	Block diagram	5
Figure 2.	Pins connection (top view)	5
Figure 3.	Definition of timing on the I2C bus.	11
Figure 4.	Typical application circuit.	11
Figure 5.	Multiwatt15 (vertical) mechanical data and package dimensions.	13

Obsolete Product(s) - Obsolete Product(s)

1 Block and pins connection diagrams

Figure 1. Block diagram

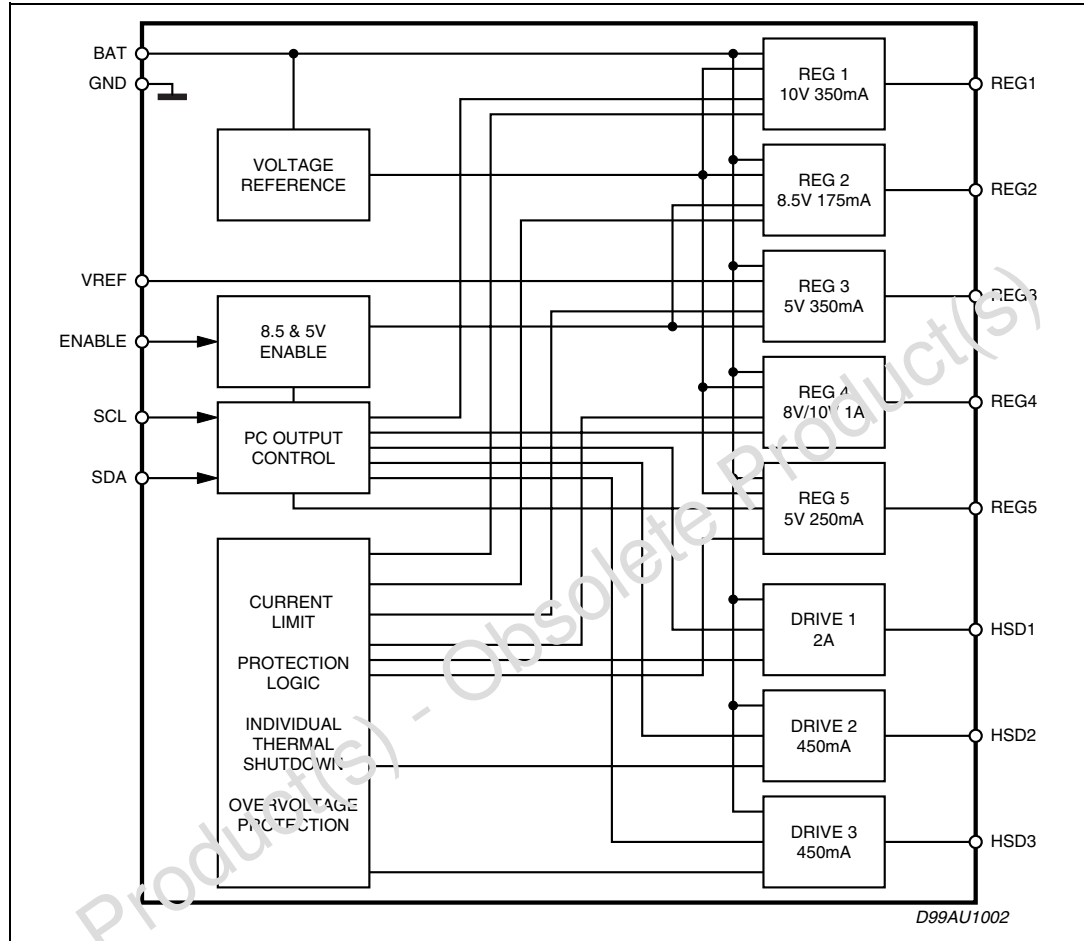
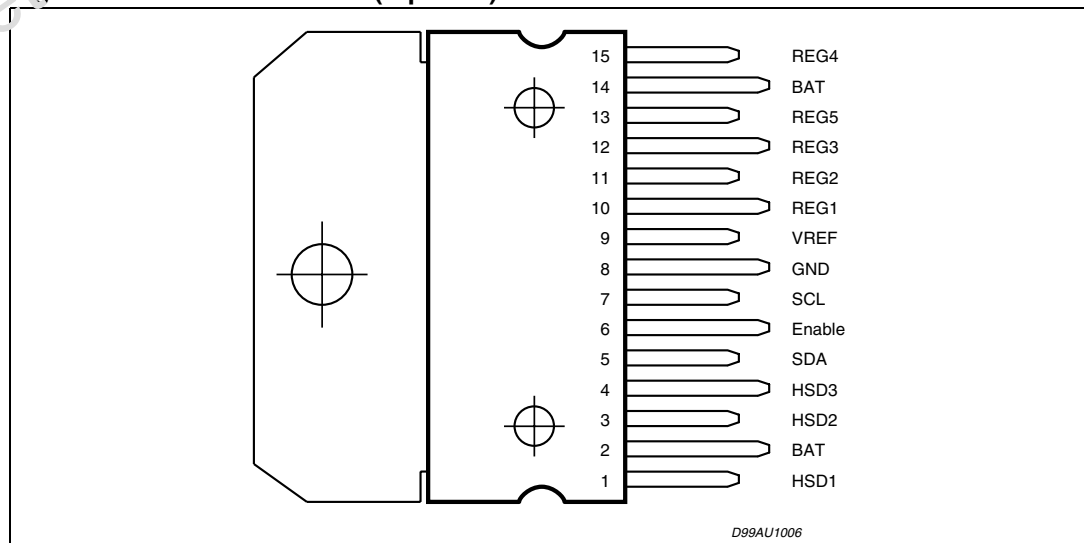

Figure 2. Pins connection (top view)



2 Electrical specifications

2.1 Absolute maximum ratings

Table 2. Absolute maximum ratings

Symbol	Parameter	Value	Unit
V_S	DC operating supply voltage	-0.6 to 26.5	V
V_S	Transient supply overvoltages, rise time = 10 ms delay time = 115 ms	34	V
V_{in}	Input voltages (EN, SDA, SCL)	-0.6 to 9	V
V_{out}	Output control voltage	-0.6 to 6.0	V
T_{op}	Operating temperature range	-40 to 85	°C
T_{stg}	Storage temperature range	-40 to 150	°C

2.2 Thermal data

Table 3. Thermal data

Symbol	Parameter	Value	Unit
$R_{th\ j-case}$	thermal resistance junction-to-case	2	°C/W

2.3 Electrical characteristics

Refer to the application circuit, $V_S = 14.4\text{ V}$; $T_{amb} = 25\text{ °C}$; unless otherwise specified.

Table 4. Electrical characteristics

Symbol	Parameter	Test Condition	Min.	Typ.	Max.	Unit
$I_{q,ST-PV}$	Standby quiescent current	All outputs off, $V_{BAT} = 14\text{ V}$	-	-	2	μA
I_q	Maximum quiescent current	$V_{BAT} = 14\text{ V}$, $I_{REG1} = 350\text{ mA}$, $I_{REG2} = 175\text{ mA}$, $I_{REG3} = 350\text{ mA}$, $I_{REG4} = 1\text{ A}$, $I_{REG5} = 250\text{ mA}$, $I_{HSD1} = 2\text{ A}$, $I_{HSD2,3} = 450\text{ mA}$	-	-	150	mA
I_{EN}	Enable input current	$V_{BAT} = 14\text{ V}$, Enable $\geq 2\text{ V}$ $V_{BAT} = 14\text{ V}$, Enable $\geq 0.8\text{ V}$	-10	-	10	μA
V_{IL} , V_{IH}	Enable threshold voltage	$V_{BAT} = 14\text{ V}$, V_{IL} $V_{BAT} = 14\text{ V}$, V_{IH}	2	-	0.8	V
10 V / 350 mA Reg 1 output						
V_{REG1}	Output voltage	$I_{REG1} = 350\text{ mA}$ $11\text{ V} \leq V_{CC} \leq 16\text{ V}$	9.50	10	10.5	V

Table 4. Electrical characteristics (continued)

Symbol	Parameter	Test Condition	Min.	Typ.	Max.	Unit
ΔV_{line}	Line regulation	$11\text{ V} \leq V_{CC} \leq 26\text{ V}$ (Measure ΔV_{REG1} across V_{CC} range)	-	-	55	mV
ΔV_{load}	Load regulation	$5\text{ mA} \leq I_{REG1} \leq 350\text{ mA}$	-	-	55	mV
$V_{DROPOUT}$	Dropout voltage (measure V_{BAT} V_{REG1} when V_{REG1} drops 0.1 V) V_{REG1} when V_{REG1} drops 0.1 V)	(Measure V_{BAT} V_{REG1} when V_{REG1} drops 0.1 V) $I_{REG1} = 350\text{ mA}$ $I_{REG1} = 5\text{ mA}$	-	-	900 300	mV mV
I_{lim1}	Current limit	-	0.51	-	1.1	A
SVR	Ripple rejection	$f_o = 1\text{ kHz}$, $V_{BAT} = 14\text{ V}$ with 1Vpp AC $I_{REG1} = 175\text{ mA}$	50	-	-	dB
8.5 V / 175 mA Reg 2 output						
V_{REG2}	Output voltage	$I_{REG2} = 175\text{ mA}$ $9.5\text{ V} \leq V_{BAT} \leq 16\text{ V}$	8.0	8.5	9.0	V
ΔV_{line}	Line regulation	$9.5\text{ V} \leq V_{BAT} \leq 26\text{ V}$ (Measure ΔV_{REG2} across V_{BAT} Range)	-	-	50	mV
ΔV_{load}	Load regulation	$5\text{ mA} \leq I_{REG2} \leq 175\text{ mA}$	-	-	50	mV
$V_{DROPOUT}$	Dropout voltage	(Measure V_{BAT} V_{REG2} when V_{REG2} drops 0.1 V) $I_{REG2} = 175\text{ mA}$ $I_{REG2} = 5\text{ mA}$	-	-	900 300	mV mV
I_{lim2}	Current limit	-	280	-	525	mA
SVR	Ripple rejection	$f_o = 1\text{ kHz}$, $V_{BAT} = 14\text{ V}$ with 1 Vpp AC $I_{REG2} = 100\text{ mA}$	50	-	-	dB
5 V / 150 mA Reg 3 output						
V_{REG3}	Voltage offset from V_{REF}	-	-	10	40	mV
ΔV_{line}	Line regulation	$7\text{ V} \leq V_{BAT} \leq 26\text{ V}$ (Measure ΔV_{REG3} across V_{BAT} range)	-	-	50	mV
ΔV_{load}	Load regulation	$5\text{ mA} \leq I_{REG3} \leq 350\text{ mA}$	-	-	100	mV
$V_{DROPOUT}$	Dropout voltage (Measure V_{BAT} V_{REG3} when V_{REG3} drops 0.1V) V_{REG3} when V_{REG3} drops 0.1V)	(Measure V_{BAT} V_{REG3} when V_{REG3} drops 0.1 V) $I_{REG3} = 175\text{ mA}$ $I_{REG3} = 5\text{ mA}$	-	-	950 600	mV mV
I_{lim3}	Current limit	-	0.5	-	1	A
SVR	Ripple rejection	$f_o = 1\text{ kHz}$, $V_{BAT} = 14\text{ V}$ with 1 Vpp AC, $I_{REG3} = 175\text{ mA}$	50	-	-	dB

Table 4. Electrical characteristics (continued)

Symbol	Parameter	Test Condition	Min.	Typ.	Max.	Unit
8/10 V/1 A Reg 4 output						
V_{REG4}	Output voltage	$I_{REG4} = 1 \text{ A}$ $b5 = 0$ $b5 = 1$	7.6 9.50	8 10	8.4 10.5	V V
ΔV_{line}	Line regulation	$11 \text{ V} \leq V_{BAT} \leq 26 \text{ V}$, $b5 = 1$ (Measure ΔV_{REG2} across V_{BAT} Range)	-	-	50	mV
ΔV_{load}	Load regulation	$5 \text{ mA} \leq I_{REG4} \leq 1 \text{ A}$	-	-	150	mV
$V_{DROPOUT}$	Dropout voltage	(Measure V_{BAT} V_{REG2} when V_{REG2} drops 0.1 V) $I_{REG4} = 1 \text{ A}$ $I_{REG4} = 5 \text{ mA}$	-	-	950 600	mV mV
I_{lim4}	Current limit	-	1.3	-	2.4	A
SVR	Ripple rejection	$f_o = 1 \text{ kHz}$, $V_{BAT} = 14 \text{ V}$ with 1 Vpp AC, $I_{REG4} = 500 \text{ mA}$	50	-	-	dB
5 V/250 mA Reg 5 output						
V_{REG5}	Output voltage	$I_{REG5} = 250 \text{ mA}$	4.6	5	5.4	V
ΔV_{line}	Line regulation	$7 \text{ V} \leq V_{BAT} \leq 26 \text{ V}$ (Measure ΔV_{REG5} across V_{BAT} Range)	-	-	40	mV
ΔV_{load}	Load regulation	$5 \text{ mA} \leq I_{REG5} \leq 250 \text{ mA}$	-	-	100	mV
$V_{DROPOUT}$	Dropout voltage	(Measure V_{BAT} V_{REG5} when V_{REG5} drops 0.1 V) $I_{REG5} = 250 \text{ mA}$ $I_{REG5} = 5 \text{ mA}$	-	-	1.6 1.2	V V
I_{lim5}	Current limit	-	320	-	700	mA
SVR	Ripple rejection	$f_o = 1 \text{ kHz}$, $V_{BAT} = 14 \text{ V}$ with 1Vpp AC, $I_{REG5} = 125 \text{ mA}$	50	-	-	dB
2 A HSD1						
V_{sat}	Output saturation voltage	$I_{HSD1} = 1 \text{ A}$ continuous time operation	-	-	0.5	V
I_{leak1}	Output leakage current	All driver outputs are off	-50	-	50	μA
I_{lim}	Current limiting	$R_{HSD1} = 0.5 \Omega$	2.4	-	4	A

Table 4. Electrical characteristics (continued)

Symbol	Parameter	Test Condition	Min.	Typ.	Max.	Unit
0.45A HSD2 and HSD3						
V_{sat}	Output saturation voltage	$I_{HSD2,3} = 300 \text{ mA}$ Continuous time operation	-	-	0.6	V
$I_{leak2,3}$	Output leakage current	All driver outputs are off	-50	-	50	μA
I_{lim}	Current limiting	$R_{HSD2,3} = 0.5 \Omega$	0.56	-	1	A
Characteristics for I²C						
V_{IL}	Low level input voltage	-	-	-	1.5	V
V_{IH}	High level input voltage	-	3	-	-	V
V_{HYS}	Input hysteresis	-	0.2	-	-	V
V_{OL1} V_{OL2}	Low level output	Sink current = 3 mA Sink current = 6 mA	-	-	0.4 0.6	V
I_I	Input current	$0.4 \text{ V} \leq V_I \leq 0.9 V_{DDmax}$	-10	-	10	μA
f_{SCL}	SCL clock frequency	-	-	-	400	kHz

3 Functional description

The three high side drivers are a 2.0 A output (HSD1), and two 450 mA outputs (HSD2 and 3). The five regulator outputs are a 10 V at 350 mA (REG1), an 8.5 V at 175 mA (REG2), a 5 V at 350 mA (REG3), an 8 V/1.0 V at 1 A (REG4), and 5 V at 250 mA (REG5). The regulators are low dropout. The regulators will operate with output capacitors with ESR of 0.1 Ω to 5 Ω .

REG3 is referenced from the VREF input not the internal bandgap. This is done to minimize the voltage offset between individual 5 V supplies.

The REG2 and REG3 outputs are turned on and off with the Enable input, a '1' turns the outputs on and a '0' turns them off. When Enable is "1", the other outputs can be independently controlled via the I²C bus. When a given regulator is turned off it must be guaranteed to be lower than 0.2 V. The output voltage of REG4 is selected via bit 5 of the I²C data byte: 8 V is the output voltage if bit5 = '0' while 10 V is the output voltage when bit5 = '1'. When all outputs are turned off the total current draw must be minimized. I²C will run at a clock speed range of 100 kHz to 400 kHz. This device should be capable of operating at any frequency within this range.

3.1 Protection

The L5954 can survive under the following conditions: shorting the outputs to BAT and GND, loss of BAT, loss of IC GND, double battery, ESD, 34V load dump. L5954 will not handle a reverse battery condition. External components must be implemented for reverse battery protection.

3.1.1 Thermal shutdown

REG1, REG2, REG3, REG4, REG5 outputs shutdown at 160 °C and return to normal operation at 130 °C. The HSD2 and HSD3 shutdown at 160 °C and return to normal operation at 130 °C. The HSD1 will go into thermal shutdown at 170 °C and returns to operation at 120 °C.

3.1.2 Current limiting

Each voltage regulator will contain its own current protection.

3.1.3 Short circuit

If the outputs are short circuited, the IC will go into current limiting and eventually the thermal shutdown will kick in. Current limiting will not disable the outputs.

3.1.4 Overvoltage

The IC will not operate if the BAT voltage reaches 27 V typ. or above.

Figure 3. Definition of timing on the I²C bus.

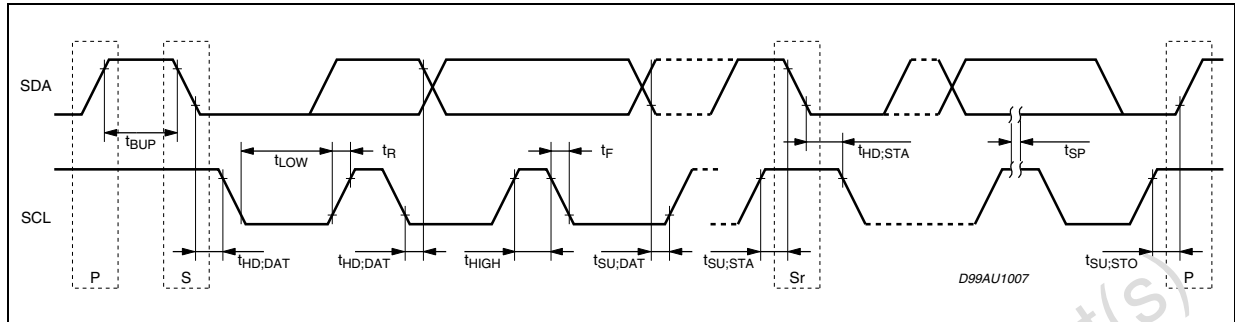
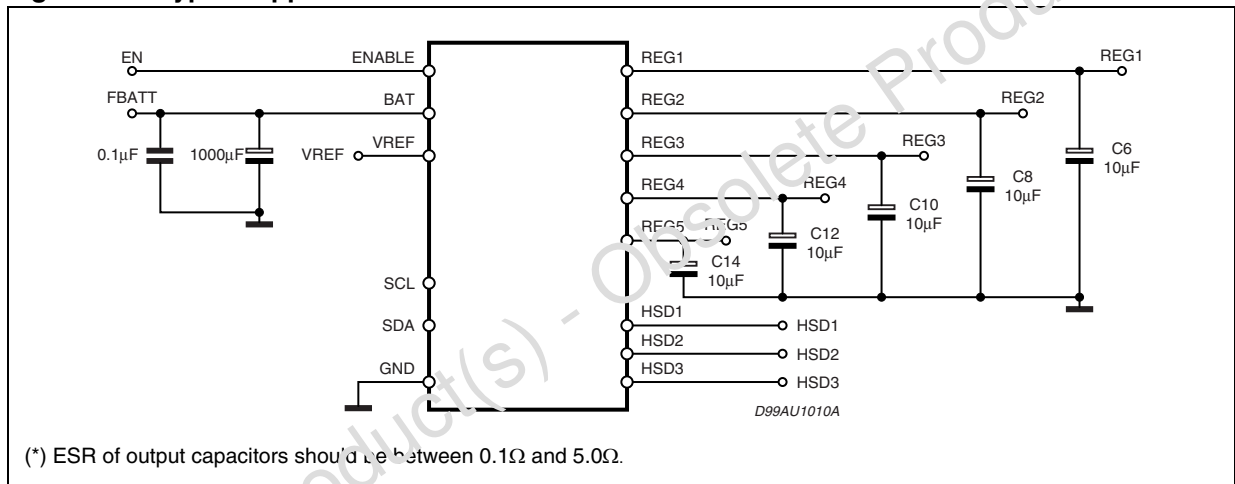
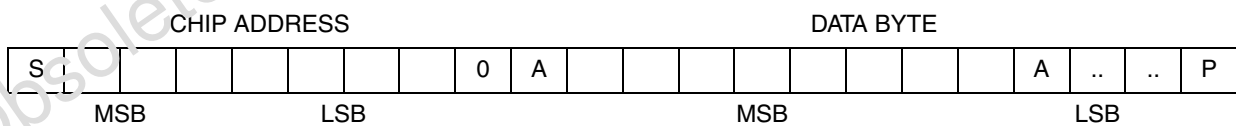

Figure 4. Typical application circuit.



(*) ESR of output capacitors should be between 0.1Ω and 5.0Ω.

3.1.5 Write mode



S = START condition - SDA goes from high to low while SCL is high

A = Acknowledge - the device being written to, pulls down on data line (SDA) during the acknowledge clock pulse.

P = STOP condition - SDA goes from low to high while SCL is high.

3.1.6 Chip address byte

Chip address							Read/write
A7	A6	A5	A4	A3	A2	A1	A0
0	0	0	1	0	0	0	0

3.1.7 Data byte

Data byte							
REG1		R4 10V	REG4	REG5	HSD1	HSD2	HSD3
b7	b6	b5	b4	b3	b2	b1	b0
	X						

Default mode is 0000 0000 which corresponds to all outputs being off, low power mode.

Bit 5 Controls the output voltage of REG4. A '0' corresponds to 8 V and a '1' corresponds to 10 V.

4 Package information

In order to meet environmental requirements, ST offers these devices in different grades of ECOPACK® packages, depending on their level of environmental compliance. ECOPACK® specifications, grade definitions and product status are available at: www.st.com.

ECOPACK® is an ST trademark.

Figure 5. Multiwatt15 (vertical) mechanical data and package dimensions

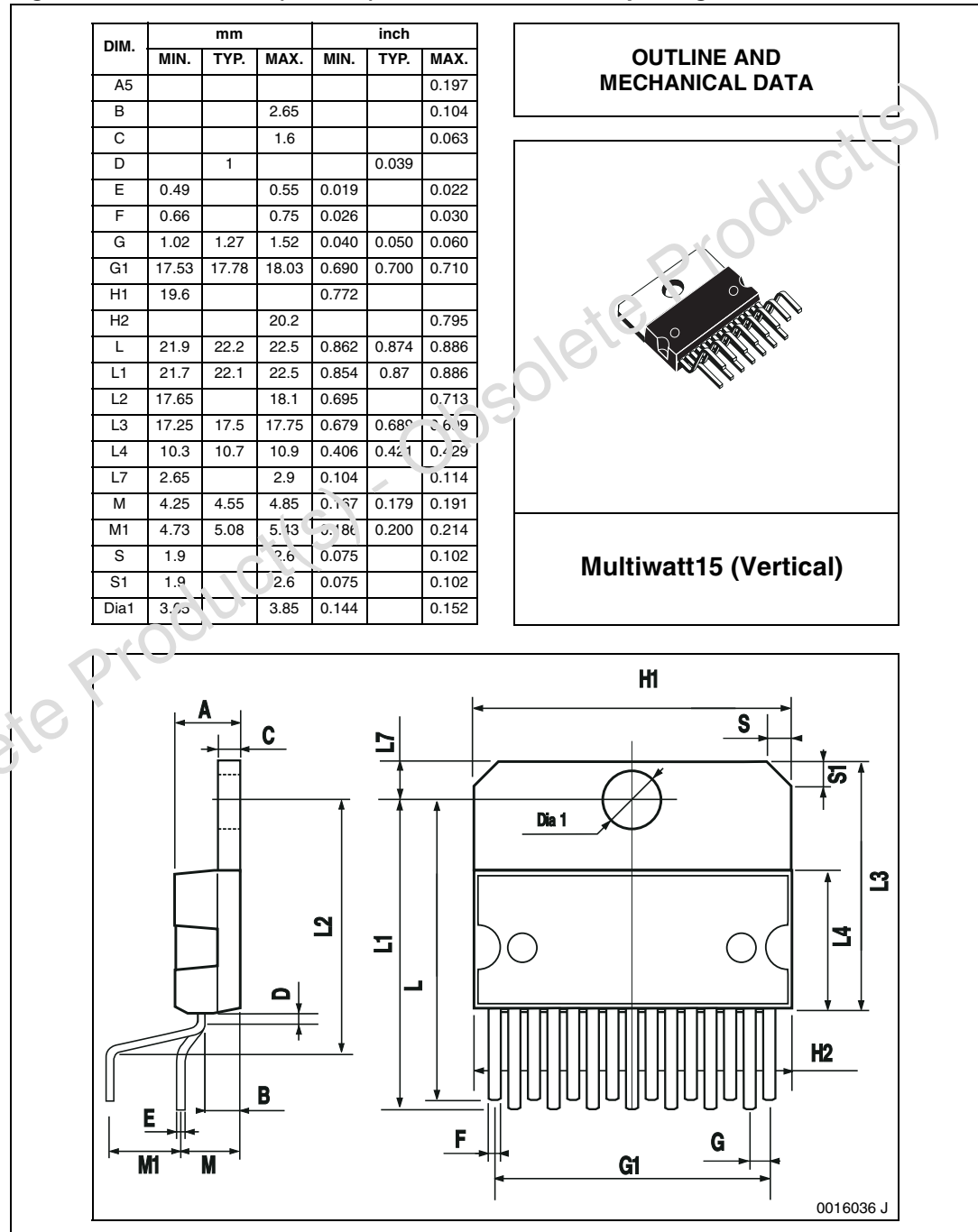

5 Revision history

Table 5. Document revision history

Date	Revision	Changes
09-Jul-2010	1	Initial release.

Obsolete Product(s) - Obsolete Product(s)

Please Read Carefully:

Information in this document is provided solely in connection with ST products. STMicroelectronics NV and its subsidiaries ("ST") reserve the right to make changes, corrections, modifications or improvements, to this document, and the products and services described herein at any time, without notice.

All ST products are sold pursuant to ST's terms and conditions of sale.

Purchasers are solely responsible for the choice, selection and use of the ST products and services described herein, and ST assumes no liability whatsoever relating to the choice, selection or use of the ST products and services described herein.

No license, express or implied, by estoppel or otherwise, to any intellectual property rights is granted under this document. If any part of this document refers to any third party products or services it shall not be deemed a license grant by ST for the use of such third party products or services, or any intellectual property contained therein or considered as a warranty covering the use in any manner whatsoever of such third party products or services or any intellectual property contained therein.

UNLESS OTHERWISE SET FORTH IN ST'S TERMS AND CONDITIONS OF SALE ST DISCLAIMS ANY EXPRESS OR IMPLIED WARRANTY WITH RESPECT TO THE USE AND/OR SALE OF ST PRODUCTS INCLUDING WITHOUT LIMITATION IMPLIED WARRANTIES OF MERCHANTABILITY, FITNESS FOR A PARTICULAR PURPOSE (AND THEIR EQUIVALENTS UNDER THE LAWS OF ANY JURISDICTION), OR INFRINGEMENT OF ANY PATENT, COPYRIGHT OR OTHER INTELLECTUAL PROPERTY RIGHT.

UNLESS EXPRESSLY APPROVED IN WRITING BY AN AUTHORIZED ST REPRESENTATIVE, ST PRODUCTS ARE NOT RECOMMENDED, AUTHORIZED OR WARRANTED FOR USE IN MILITARY, AIR CRAFT, SPACE, LIFE SAVING, OR LIFE SUSTAINING APPLICATIONS, NOR IN PRODUCTS OR SYSTEMS WHERE FAILURE OR MALFUNCTION MAY RESULT IN PERSONAL INJURY, DEATH, OR SEVERE PROPERTY OR ENVIRONMENTAL DAMAGE. ST PRODUCTS WHICH ARE NOT SPECIFIED AS "AUTOMOTIVE GRADE" MAY ONLY BE USED IN AUTOMOTIVE APPLICATIONS AT USER'S OWN RISK.

Resale of ST products with provisions different from the statements and/or technical features set forth in this document shall immediately void any warranty granted by ST for the ST product or service described herein and shall not create or extend in any manner whatsoever, any liability of ST.

ST and the ST logo are trademarks or registered trademarks of ST in various countries.

Information in this document supersedes and replaces all information previously supplied.

The ST logo is a registered trademark of STMicroelectronics. All other names are the property of their respective owners.

© 2010 STMicroelectronics - All rights reserved

STMicroelectronics group of companies

Australia - Belgium - Brazil - Canada - China - Czech Republic - Finland - France - Germany - Hong Kong - India - Israel - Italy - Japan - Malaysia - Malta - Morocco - Philippines - Singapore - Spain - Sweden - Switzerland - United Kingdom - United States of America

www.st.com