



Chipsmall Limited consists of a professional team with an average of over 10 year of expertise in the distribution of electronic components. Based in Hongkong, we have already established firm and mutual-benefit business relationships with customers from,Europe,America and south Asia,supplying obsolete and hard-to-find components to meet their specific needs.

With the principle of "Quality Parts,Customers Priority,Honest Operation,and Considerate Service",our business mainly focus on the distribution of electronic components. Line cards we deal with include Microchip,ALPS,ROHM,Xilinx,Pulse,ON,Everlight and Freescale. Main products comprise IC,Modules,Potentiometer,IC Socket,Relay,Connector.Our parts cover such applications as commercial,industrial, and automotives areas.

We are looking forward to setting up business relationship with you and hope to provide you with the best service and solution. Let us make a better world for our industry!



Contact us

Tel: +86-755-8981 8866 Fax: +86-755-8427 6832

Email & Skype: info@chipsmall.com Web: www.chipsmall.com

Address: A1208, Overseas Decoration Building, #122 Zhenhua RD., Futian, Shenzhen, China



DMOS driver for three-phase brushless DC motor

Datasheet - production data

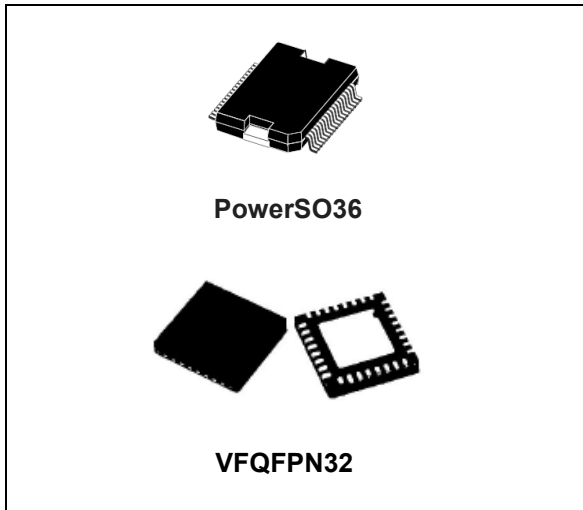

Description

The L6230 is a DMOS fully integrated three-phase motor driver with overcurrent protection, optimized for FOC application thanks to the independent current senses.

Realized in BCDmultipower technology, the device combines isolated DMOS power transistors with CMOS and bipolar circuits on the same chip.

An uncommitted comparator with open-drain output is available.

Available in PowerSO36 and VFQFPN32 5 x 5 packages the L6230 device features non-dissipative overcurrent protection on the high-side power MOSFETs and thermal shutdown.

Features

- Operating supply voltage from 8 to 52 V
- 2.8 A output peak current (1.4 A RMS)
- $R_{DS(on)}$ 0.73 Ω typ. value at $T_J = 25^\circ\text{C}$
- Integrated fast freewheeling diodes
- Operating frequency up to 100 kHz
- Non-dissipative overcurrent detection and protection
- Cross conduction protection
- Diagnostic output
- Uncommitted comparator
- Thermal shutdown
- Undervoltage lockout

Application

- BLDC motor driving
- Sinusoidal / six-step driving
- Field oriented control driving system

Table 1. Device summary

Order codes	Package	Packaging
L6230PD	PowerSO36	Tube
L6230PDTR		Tape and reel
L6230Q	VFQFPN32	Tube
L6230QTR		Tape and reel

Contents

- 1 Block diagram 3**
- 2 Electrical data 4**
 - 2.1 Absolute maximum ratings 4
 - 2.2 Recommended operating conditions 4
 - 2.3 Thermal data 5
- 3 Pin connection 6**
- 4 Electrical characteristics 8**
- 5 Circuit description 11**
 - 5.1 Power stages and charge pump 11
 - 5.2 Logic inputs 12
 - 5.3 Non-dissipative overcurrent detection and protection 13
- 6 Application information 15**
 - 6.1 Field oriented control driving method 16
 - 6.2 Six-step driving method with current control 17
 - 6.3 Six-step driving method with BEMF zero-crossing detection 18
 - 6.4 Thermal management 19
- 7 Package information 20**
 - 7.1 VFQFPN32 package information 20
 - 7.2 PowerSO36 package information 22
- 8 Revision history 24**

1 Block diagram

Figure 1. Block diagram

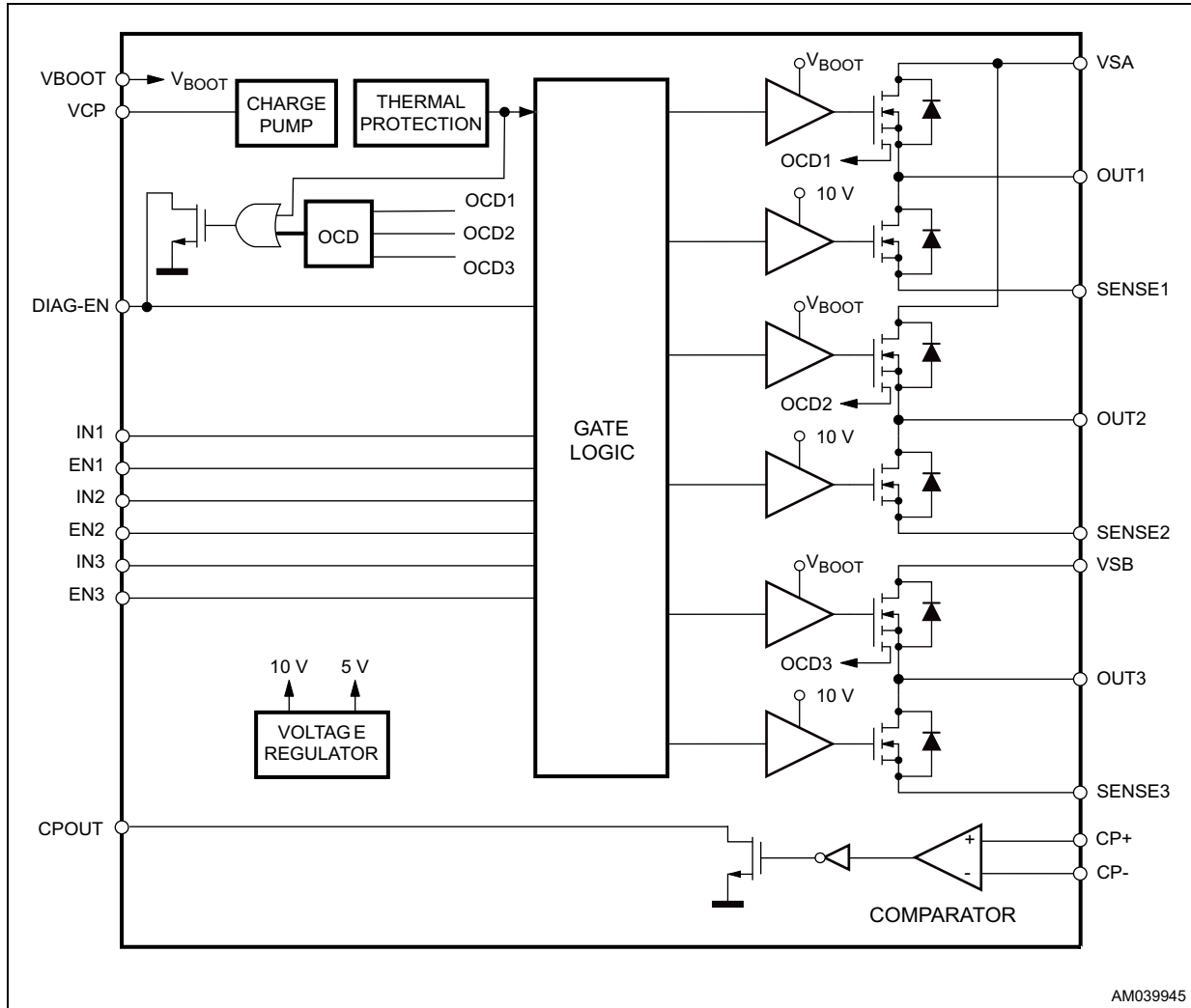

AM039945

2 Electrical data

2.1 Absolute maximum ratings

Table 2. Absolute maximum ratings

Symbol	Parameter	Parameter	Value	Unit
V_S	Supply voltage	$V_{SA} = V_{SB} = V_S$	60	V
V_{OD}	Differential voltage between: VSA, OUT1, OUT2, SENSE1, SENSE2 and VSB, OUT3, SENSE3	$V_{SA} = V_{SB} = V_S = 60\text{ V};$ $V_{SENSEx} = \text{GND}$	60	V
V_{BOOT}	Bootstrap peak voltage	$V_{SA} = V_{SB} = V_S$	$V_S + 10$	V
V_{IN}, V_{EN}	Logic inputs voltage range		-0.3 to +7	V
V_{CP-}, V_{CP+}	Voltage range at CP- and CP+ pins		-0.3 to +7	V
V_{SENSE}	Voltage range at SENSEx pins		-1 to +4	V
$I_{S(\text{peak})}$	Pulsed supply current (for each VS pin)	$V_{SA} = V_{SB} = V_S;$ $T_{PULSE} < 1\text{ ms}$	3.55	A
I_S	RMS supply current (for each VS pin)	$V_{SA} = V_{SB} = V_S$	1.4	A
T_{stg}, T_{OP}	Storage and operating temperature range		-40 to 150	°C

2.2 Recommended operating conditions

Table 3. Recommended operating conditions

Symbol	Parameter	Parameter	Min	Max	Unit
V_S	Supply voltage	$V_{SA} = V_{SB} = V_S$	8	52	V
V_{OD}	Differential voltage between VSA, OUT1A, OUT2A, SENSE1, SENSE2 and VSB, OUT1B, OUT2B, SENSE3	$V_{SA} = V_{SB} = V_S;$ $V_{SENSE1} = V_{SENSE2} = V_{SENSE3}$		52	V
V_{CP-}, V_{CP+}	Voltage range at CP- and CP+ pins		-0.1	5	V
V_{CPCM}	Common mode voltage at the comparator inputs		0	3	V
V_{SENSE}	Voltage range at pins SENSEx	pulsed $t_W < t_{rr}$	-6	6	V
		DC	-1	1	V
I_{OUT}	RMS output current			1.4	A
T_J	Operating junction temperature		-25	+125	°C
f_{sw}	Switching frequency			100	kHz

2.3 Thermal data

Table 4. Thermal data

Symbol	Parameter	Value		Unit
		PowerSO36	VFQFPN32	
$R_{th(j-amb)1}$	Maximum thermal resistance junction ambient ⁽¹⁾	36	-	°C/W
$R_{th(j-amb)1}$	Maximum thermal resistance junction ambient ⁽²⁾	16	-	°C/W
$R_{th(j-amb)2}$	Maximum thermal resistance junction ambient ⁽³⁾	63	-	°C/W
$R_{th(j-amb)3}$	Maximum thermal resistance junction ambient ⁽⁴⁾	-	42	°C/W

1. Mounted on a multi-layer FR4 PCB with a dissipating copper surface on the top side of 6 cm² (with a thickness of 35 μm).
2. Mounted on a multi-layer FR4 PCB with a dissipating copper surface on the top side of 6 cm² (with a thickness of 35 μm), 16 via holes and a ground layer.
3. Mounted on a multi-layer FR4 PCB without any heat-sinking surface on the board.
4. Mounted on a double-layer FR4 PCB with a dissipating copper surface of 0.5 cm² on the top side plus 6 cm² ground layer connected through 18 via holes (9 below the IC).

3 Pin connection

Figure 2. Pin connection PowerSO36 (top view)

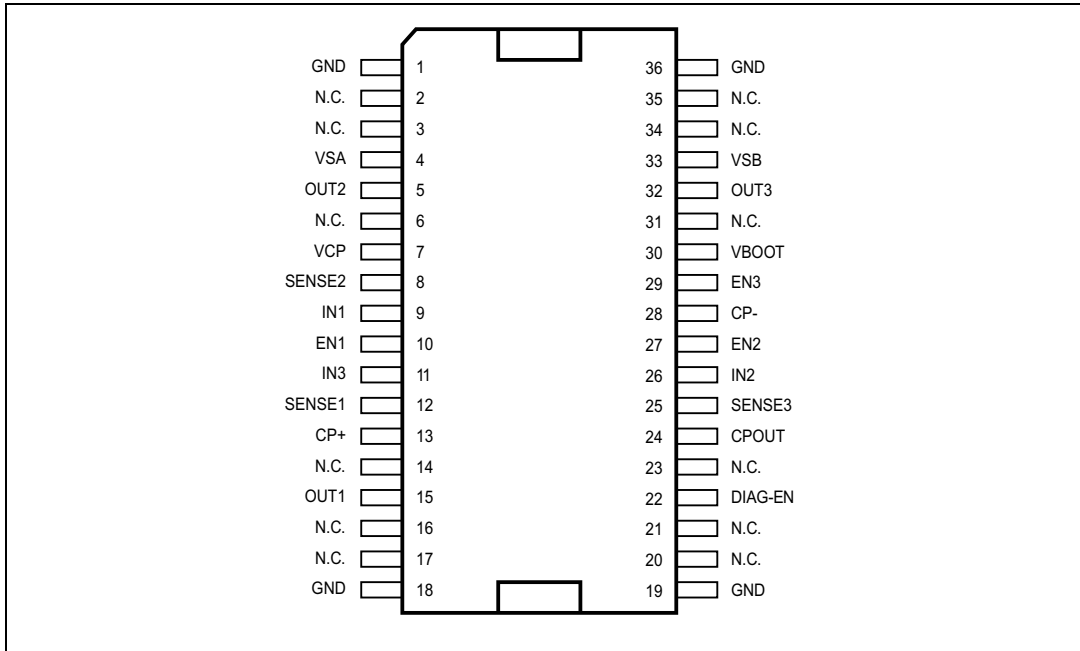

Note: The slug is internally connected to pins 1, 18, 19, and 36 (GND pins).

Figure 3. Pin connection VFQFPN32 (top view)

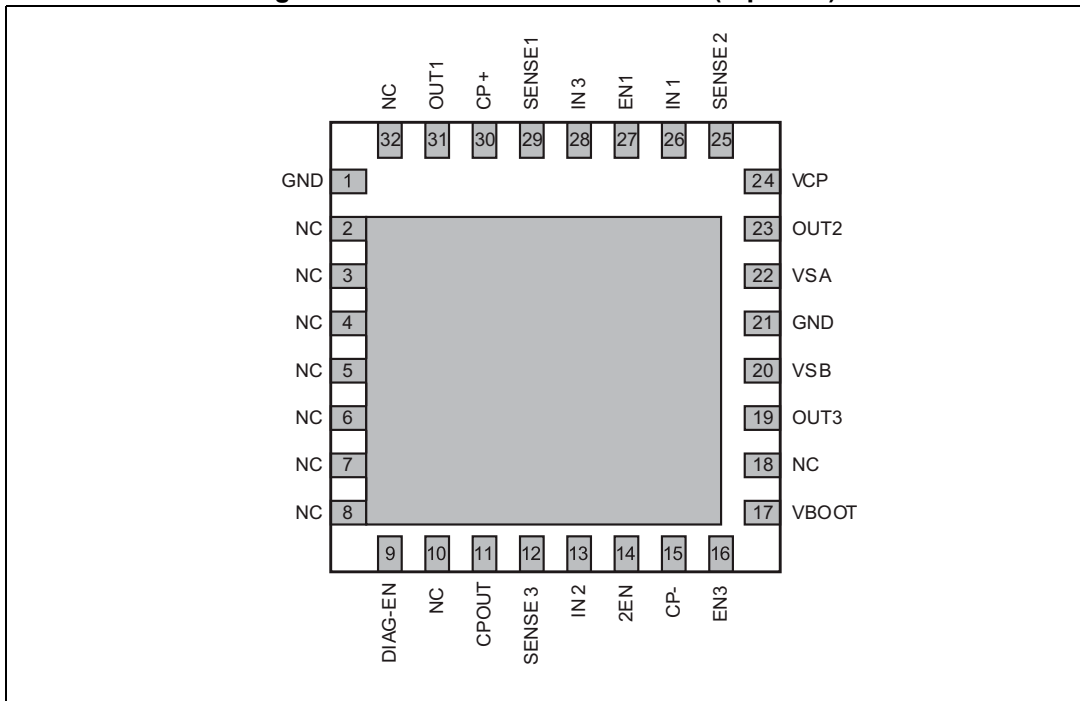

Note: The pins 2 to 8 are connected to the die PAD.
The die PAD must be connected to the GND pin.

Table 5. Pin description

Pin	Type	Function
VBOOT	Power supply	Bootstrap voltage needed for driving the upper power MOSFETs.
VCP	Output	Charge pump oscillator output.
DIAG-EN	Logic output/input	Double function: chip Enable as input and overcurrent/overtemperature indication as output. LOW logic level switches OFF all power MOSFETs, putting the power stages in high impedance status. An internal open-drain transistor pulls to GND the pin when an overcurrent on one of the high-side MOSFETs is detected or during thermal protection.
IN1	Logic input	Logic input half bridge 1.
EN1	Logic input	Enable input half bridge 1.
IN2	Logic input	Logic input half bridge 2.
EN2	Logic input	Enable input half bridge 2.
IN3	Logic input	Logic input half bridge 3.
EN3	Logic input	Enable input half bridge 3.
CP-	Analog input	Inverting input of internal comparator.
CP+	Analog input	Non-inverting input of internal comparator.
CPOUT	Output	Open-drain output of internal comparator.
SENSE3		Half bridge 3 source pin. This pin must be connected to power ground through a sensing power resistor.
OUT3	Power output	Output half bridge 3.
VSB	Power supply	Half bridge 3 power supply voltage. It must be connected to the supply voltage together with pin VSA.
SENSE2		Half bridge 2 source pin. This pin must be connected to power ground through a sensing power resistor.
OUT2	Power output	Output half bridge 2.
SENSE1		Half bridge 1 source pin. This pin must be connected to power ground through a sensing power resistor.
OUT1	Power output	Output half bridge 1.
VSA	Power supply	Half bridge 1 and half bridge 2 power supply voltage. It must be connected to the supply voltage together with pin VSB.
GND	Ground	Ground terminal.

4 Electrical characteristics

$V_S = 48\text{ V}$, $T_A = 25\text{ °C}$, unless otherwise specified.

Table 6. Electrical characteristics

Symbol	Parameter	Test condition	Min.	Typ.	Max.	Unit
$V_{Sth(ON)}$	Turn-on threshold		5.8	6.3	6.8	V
$V_{Sth(OFF)}$	Turn-off threshold		5	5.5	6	V
I_S	Quiescent supply current	All bridges OFF; $T_J = -25\text{ °C to }125\text{ °C}^{(1)}$		5	10	mA
$T_{j(OFF)}$	Thermal shutdown temperature			165		°C
Output DMOS transistors						
$R_{DS(on)}$	High-side / low-side switch ON resistance	$T_J = 25\text{ °C}$		0.73	0.85	Ω
		$T_J = 125\text{ °C}^{(1)}$		1.18	1.35	Ω
I_{DSS}	Leakage current	DIAG-EN = LOW; OUT = V_S			2	mA
		DIAG-EN = LOW; OUT = GND	-0.3			mA
Source drain diodes						
V_{SD}	Forward ON voltage	$I_{SD} = 1.4\text{ A}$, DIAG-EN = LOW		1.15	1.3	V
t_{rr}	Reverse recovery time	$I_f = 1.4\text{ A}$		300		ns
t_{fr}	Forward recovery time			200		ns
Logic inputs (INx, ENx, DIAG-EN)						
V_{IL}	Low level logic input voltage				0.8	V
V_{IH}	High level logic input voltage		2			V
I_{IL}	Low level logic input current	GND logic input voltage	-10			μA
I_{IH}	High level logic input current	7 V logic input voltage			10	μA
Switching characteristics						
$t_{D(ON)EN}$	Enable to output turn-on delay time ⁽²⁾	$I_{LOAD} = 1.4\text{ A}$, resistive load	500	650	800	ns
$t_{D(OFF)EN}$	Enable to output turn-off delay time ⁽²⁾		500		1000	ns
$t_{D(ON)IN}$	Other logic inputs to OUT turn-ON delay time			1.6		μs
$t_{D(OFF)IN}$	Other logic inputs to OUT turn-OFF delay time			800		ns
t_{RISE}	Output rise time ⁽²⁾		40		250	ns
t_{FALL}	Output fall time ⁽²⁾		40		250	ns
t_{DT}	Dead time		0.5	1		μs
f_{CP}	Charge pump frequency		$T_J = -25\text{ °C to }125\text{ °C}^{(1)}$		0.6	1

Table 6. Electrical characteristics (continued)

Symbol	Parameter	Test condition	Min.	Typ.	Max.	Unit
Comparator						
V_{OFFSET}	Offset voltage	$V_{\text{CP-}} = 0.5 \text{ V}$	-14		+14	mV
t_{prop}	Propagation delay	(3)		500		ns
I_{BIAS}	Inputs bias current				10	μA
R_{CPOUT}	Open-drain ON resistance			40	60	Ω
Overcurrent detection and protection						
I_{SOVER}	Supply overcurrent protection threshold	$T_{\text{J}} = -25 \text{ to } 125 \text{ }^\circ\text{C}^{(1)}$	2	2.8	3.55	A
R_{DIAG}	Open-drain ON resistance	$I_{\text{DIAG}} = 4 \text{ mA}$		40	60	Ω
$t_{\text{OCD(ON)}}$	OCD turn-ON delay time ⁽⁴⁾	$I_{\text{DIAG}} = 4 \text{ mA}; C_{\text{DIAG}} < 100 \text{ pF}$		200		ns
$t_{\text{OCD(OFF)}}$	OCD turn-OFF delay time ⁽⁴⁾	$I_{\text{DIAG}} = 4 \text{ mA}; C_{\text{DIAG}} < 100 \text{ pF}$		100		ns

1. Tested at 25 °C in a restricted range and guaranteed by characterization.
2. See [Figure 4](#).
3. Measured applying a voltage of 1 V to the pin CP- and a voltage drop from 2 V to 0 V to the pin CP+.
4. See [Figure 5](#).

Figure 4. Switching characteristic definition

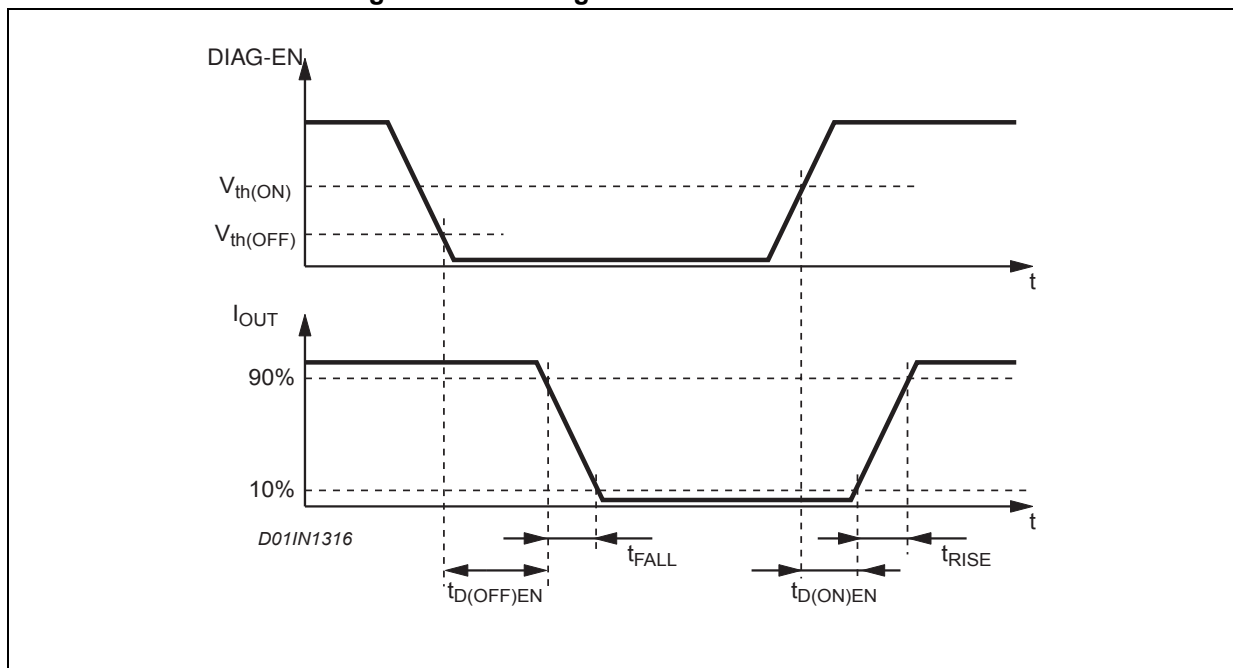
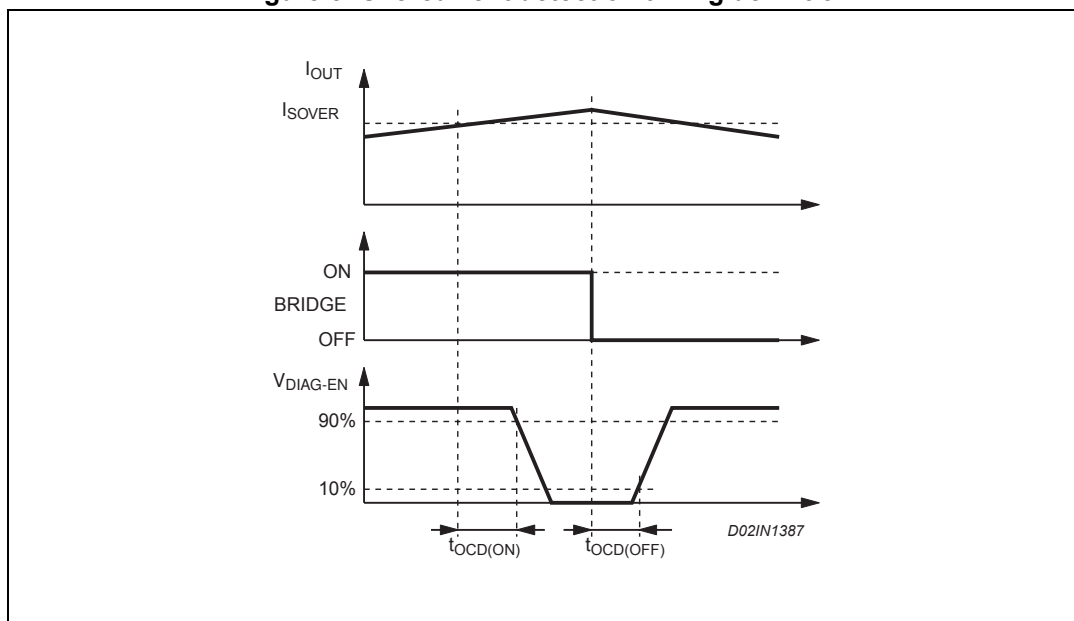

Figure 5. Overcurrent detection timing definition



5 Circuit description

5.1 Power stages and charge pump

The L6230 device integrates a three-phase bridge, which consists of 6 power MOSFETs connected as shown in the block diagram (see [Figure 1 on page 3](#)), each power MOS has an $R_{DS(ON)} = 0.73 \Omega$ (typical value at 25 °C) with an intrinsic fast freewheeling diode. Cross conduction protection is implemented by using a dead time ($t_{DT} = 1 \mu s$ typical value) set by the internal timing circuit between the turn off and turn on of two power MOSFETs in one leg of a bridge.

Pins VSA and VSB must be connected together to the supply voltage (V_S).

Using the N-channel power MOS for the upper transistors in the bridge requires a gate drive voltage above the power supply voltage. The bootstrapped supply (V_{BOOT}) is obtained through an internal oscillator and few external components to realize a charge pump circuit as shown in [Figure 6](#). The oscillator output (pin VCP) is a square wave at 600 kHz (typically) with 10 V amplitude. Recommended values/part numbers for the charge pump circuit are shown in [Table 7](#).

Table 7. Charge pump external component values

Component	Value
C_{BOOT}	220 nF
C_P	10 nF
D1	1N4148
D2	1N4148

Figure 6. Charge pump circuit

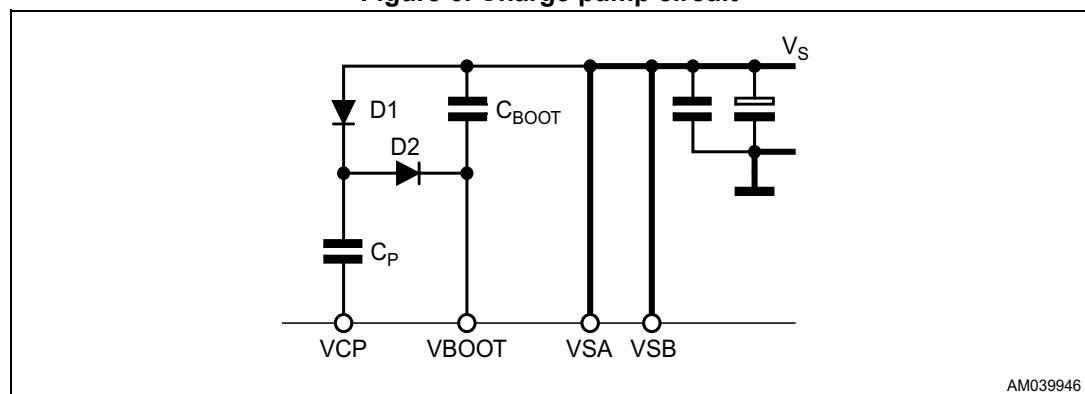

5.2 Logic inputs

Pins INx and ENx are TTL/CMOS and microcontroller compatible logic inputs. The internal structure is shown in [Figure 7](#). Typical value for turn-on and turn-off thresholds are respectively $V_{th(ON)} = 1.8\text{ V}$ and $V_{th(OFF)} = 1.3\text{ V}$.

The pin DIAG-EN has identical input structure with the exception that the drain of the overcurrent and thermal protection MOSFET is also connected to this pin. Due to this connection some care needs to be taken in driving this pin. The EN input may be driven in one of two configurations as shown in [Figure 8](#) or [Figure 9](#). If driven by an open-drain (collector) structure, a pull-up resistor R_{EN} and a capacitor C_{EN} are connected as shown in [Figure 8](#). If the driver is a standard push-pull structure the resistor R_{EN} and the capacitor C_{EN} are connected as shown in [Figure 9](#). The resistor R_{EN} should be chosen in the range from 2.2 kΩ to 180 kΩ. Recommended values for R_{EN} and C_{EN} are respectively 10 kΩ and 5.6 nF. More information on selecting the values can be found in [Section 5.3: Non-dissipative overcurrent detection and protection](#).

Figure 7. Logic inputs internal structure

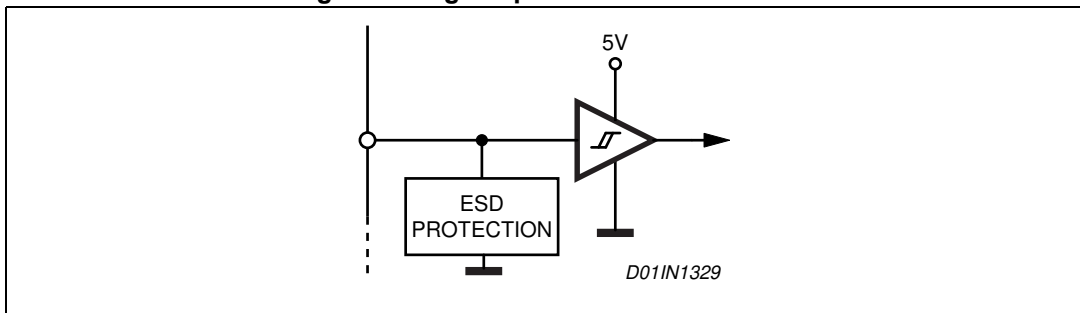

Figure 8. Pin DIAG-EN open collector driving

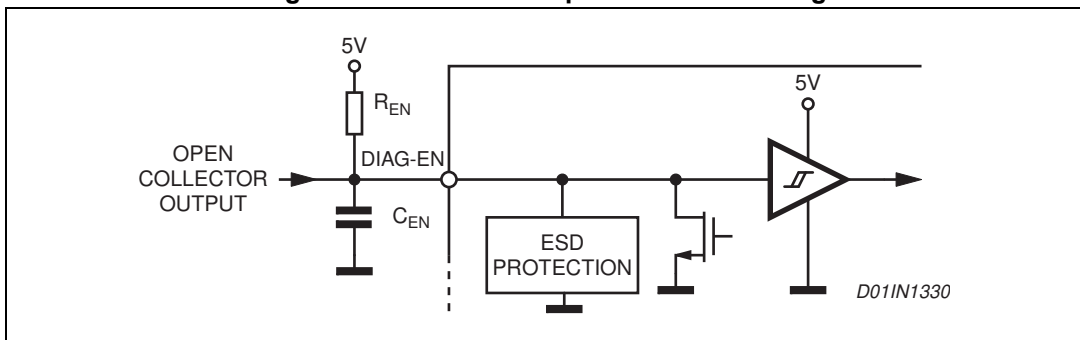
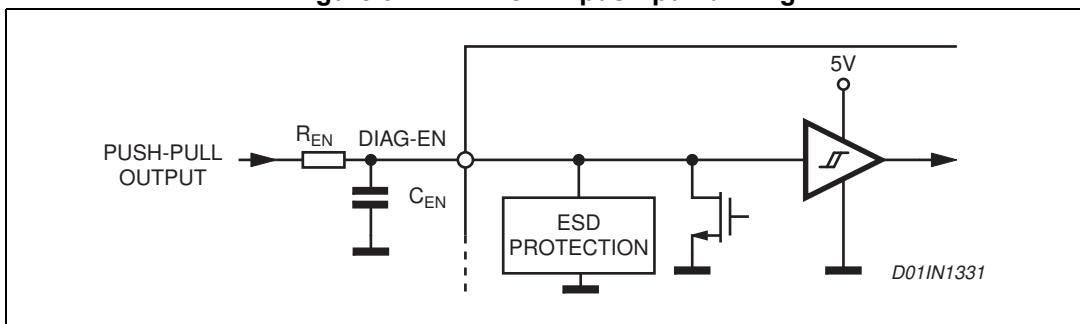

Figure 9. Pin DIAG-EN push-pull driving



5.3 Non-dissipative overcurrent detection and protection

The L6230 device integrates an overcurrent detection circuit (OCD) for full protection. This circuit provides output-to-output and output-to-ground short-circuit protection as well. With this internal overcurrent detection, the external current sense resistor normally used and its associated power dissipation are eliminated. *Figure 10* shows a simplified schematic for the overcurrent detection circuit.

To implement the overcurrent detection, a sensing element that delivers a small but precise fraction of the output current is implemented with each high-side power MOS. Since this current is a small fraction of the output current there is very little additional power dissipation. This current is compared with an internal reference current I_{REF} . When the output current reaches the detection threshold (typically $I_{SOVER} = 2.8\text{ A}$), the OCD comparator signals a fault condition. When a fault condition is detected, an internal open-drain MOS with a pull down capability of 4 mA connected to the pin DIAG is turned on.

The pin DIAG-EN can be used to signal the fault condition to a μC and to shut down the three-phase bridge simply by connecting the pin to an external R-C (see R_{EN} , C_{EN}).

Figure 10. Overcurrent protection simplified schematic

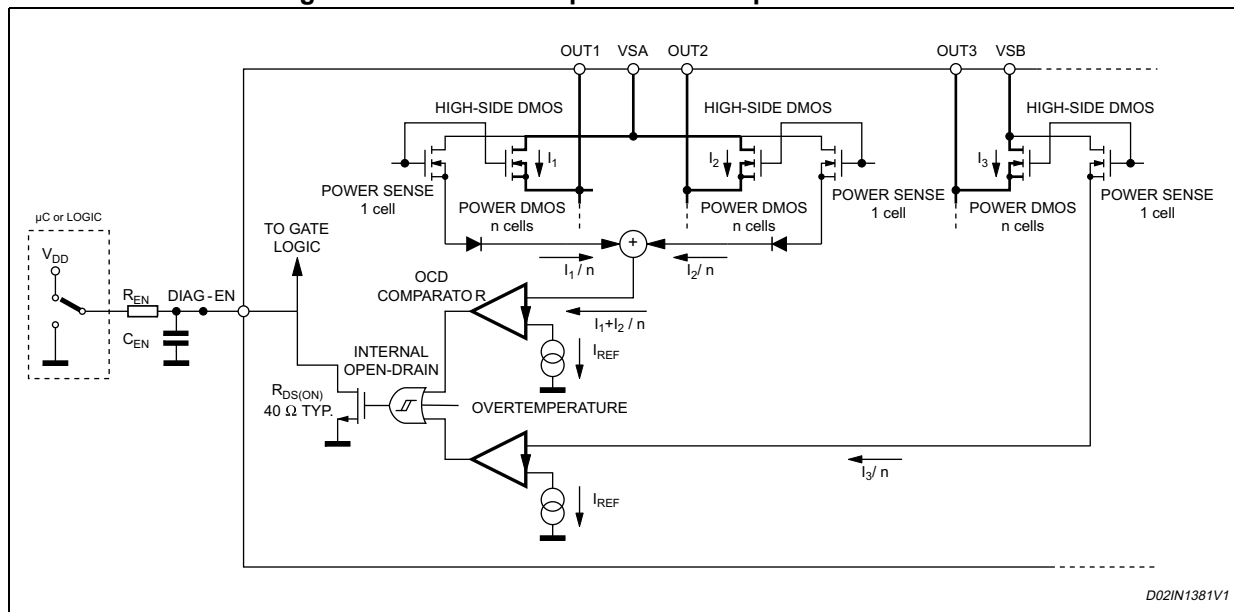

Figure 11 shows the overcurrent detection operation. The disable time $t_{DISABLE}$ before recovering the normal operation can be easily programmed by means of the accurate thresholds of the logic inputs. It is affected whether by C_{EN} and R_{EN} values and its magnitude is reported in *Figure 12*. The delay time t_{DELAY} before turning off the bridge when an overcurrent has been detected depends only by the C_{EN} value. Its magnitude is reported in *Figure 13*.

The C_{EN} is also used for providing immunity to the pin DIAG-EN against fast transient noises. Therefore the value of the C_{EN} should be chosen as big as possible according to the maximum tolerable delay time and the R_{EN} value should be chosen according to the desired disable time.

The resistor R_{EN} should be chosen in the range from 2.2 k Ω to 180 k Ω . Recommended values for the R_{EN} and C_{EN} are respectively 100 k Ω and 5.6 nF that allow obtaining 200 μs disable time.

Figure 11. Overcurrent protection waveforms

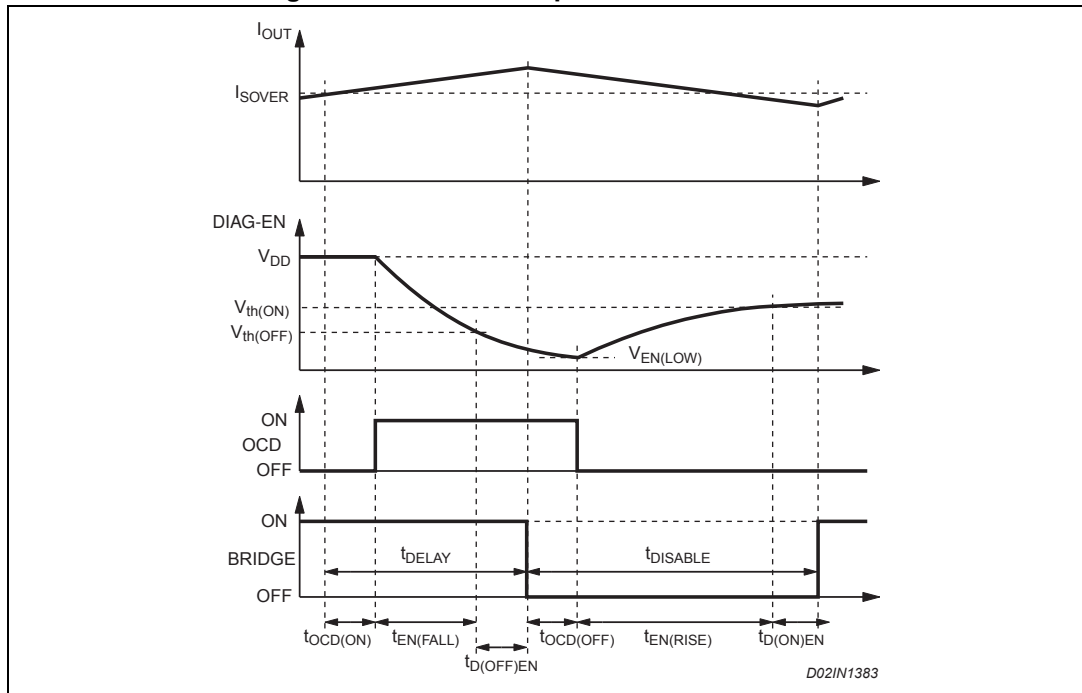

Figure 12. $t_{DISABLE}$ versus C_{EN} and R_{EN}

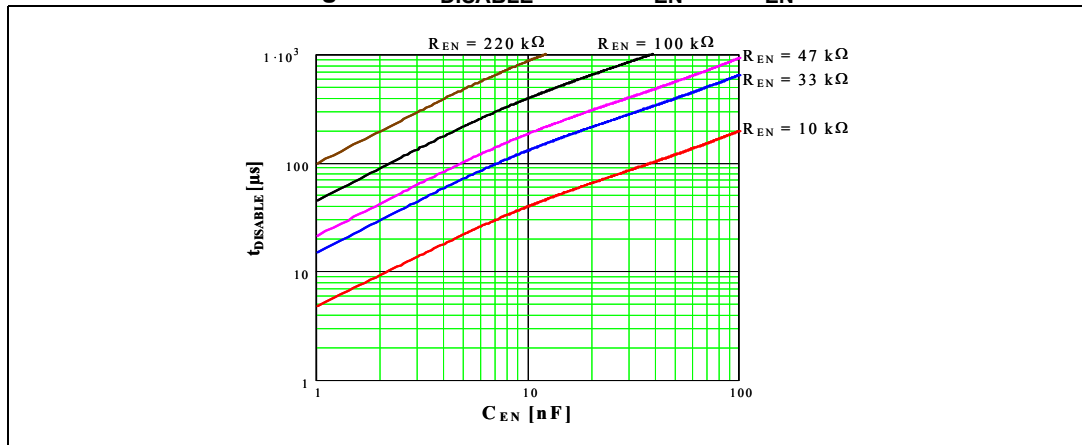
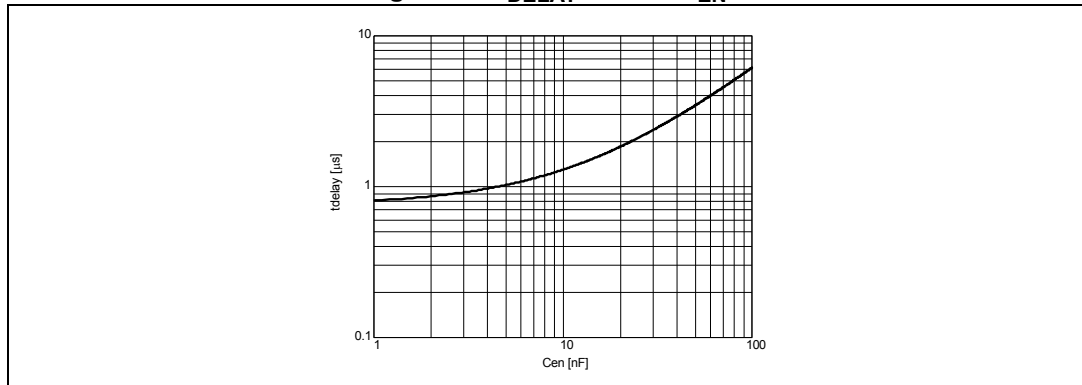

Figure 13. t_{DELAY} versus C_{EN}



6 Application information

Some typical applications using the L6230 device are shown in this section. A high quality ceramic capacitor (C_2) in the range of 100 nF to 200 nF should be placed between the power pins VS_A and VS_B and ground near the L6230 to improve the high frequency filtering on the power supply and reduce high frequency transients generated by the switching. The capacitor (C_{EN}) connected from the DIAG-EN input to ground sets the shutdown time when an overcurrent is detected (see [Section 5.3: Non-dissipative overcurrent detection and protection](#)). The current sensing inputs (SENSEX) should be connected to the sensing resistors R_{SENSE} with a trace length as short as possible in the layout. The sense resistors should be non-inductive resistors to minimize the di/dt transients across the resistors. To increase noise immunity, unused logic pins are best connected to 5 V (high logic level) or GND (low logic level) (see pin description in [Table 5 on page 10](#)). It is recommended to keep power ground and signal ground separated on the PCB.

Table 8. Component values for typical application

Component	Value
C_1	100 μ F
C_2	100 nF
C_{BOOT}	220 nF
C_{EN}	5.6 nF
C_P	10 nF
D_1	1N4148
D_2	1N4148
R_{EN}	100 k Ω

The examples reported describe some typical application to drive a 3-phase BLDC motor using the L6230 device.

In the first example is shown a field oriented control (FOC) system, with this method it is possible to provide smooth and precise motor control of BLDC motors.

A six-step driving method with current control is reported in the second example, the inputs sequence is generated by an external controller and the L6230 comparator is used to obtain the information for the peak current control.

Finally, the third example shows how to implement a sensorless motor control system, the information on the rotor position is achieved by BEMF zero-crossing detection.

6.1 Field oriented control driving method

In this configuration (see [Figure 14](#)) three sensing resistors are required, one for each channel. The sensing signals coming from the output power stage are conditioned by external operational amplifiers which provide the proper feedback signals to the AtoD converter and the system controller. According to the feedback signals the six input lines are generated by the controller.

Note that some filtering and level shifting RC networks should be added between the sense resistor and the correspondent op-amp input.

The uncommitted internal comparator with open-drain output is available.

Figure 14. F.O.C. typical application

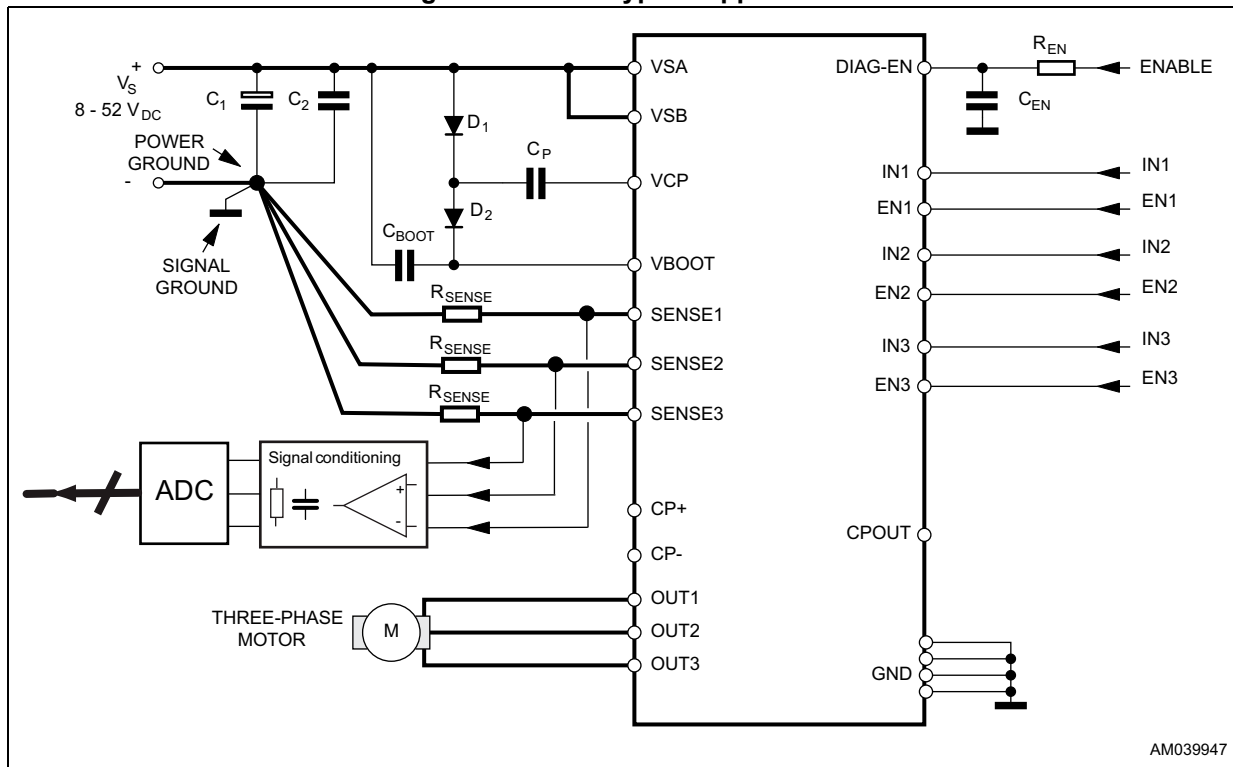

6.2 Six-step driving method with current control

In this configuration only one sense resistor is needed, the three OUT pins are connected together to the R_{SENSE} (see [Figure 15](#)).

The inverting input comparator CP- monitors the voltage drop across the external sense resistor connected between the source of the three lower power MOS transistors and ground.

As the current in the motor increases the voltage across the R_{SENSE} increases proportionally. When the voltage drop across the sense resistor becomes greater than the reference voltage applied at non-inverting input CP+ the internal open-drain is switched on pulling down the CPOUT pin.

This signal could be managed by the controller to generate the proper input sequence for the six-step driving method with current control and select what current decay method to implement.

When the sense voltage decreases below the CP+ voltage, the internal open-drain is switched off and the voltage at the CPOUT pin starts to increase charging the capacitor C_{CPOUT} .

The reference voltage at the pin CP+ will be set according to the sense resistor value and the desired regulated current ($V_{CP+} \approx R_{SENSE} \times I_{TARGET}$). A very simple way to obtain variable voltage is the low-pass filtering of the PWM signal coming from a controller.

Figure 15. Six-step with current control typical application

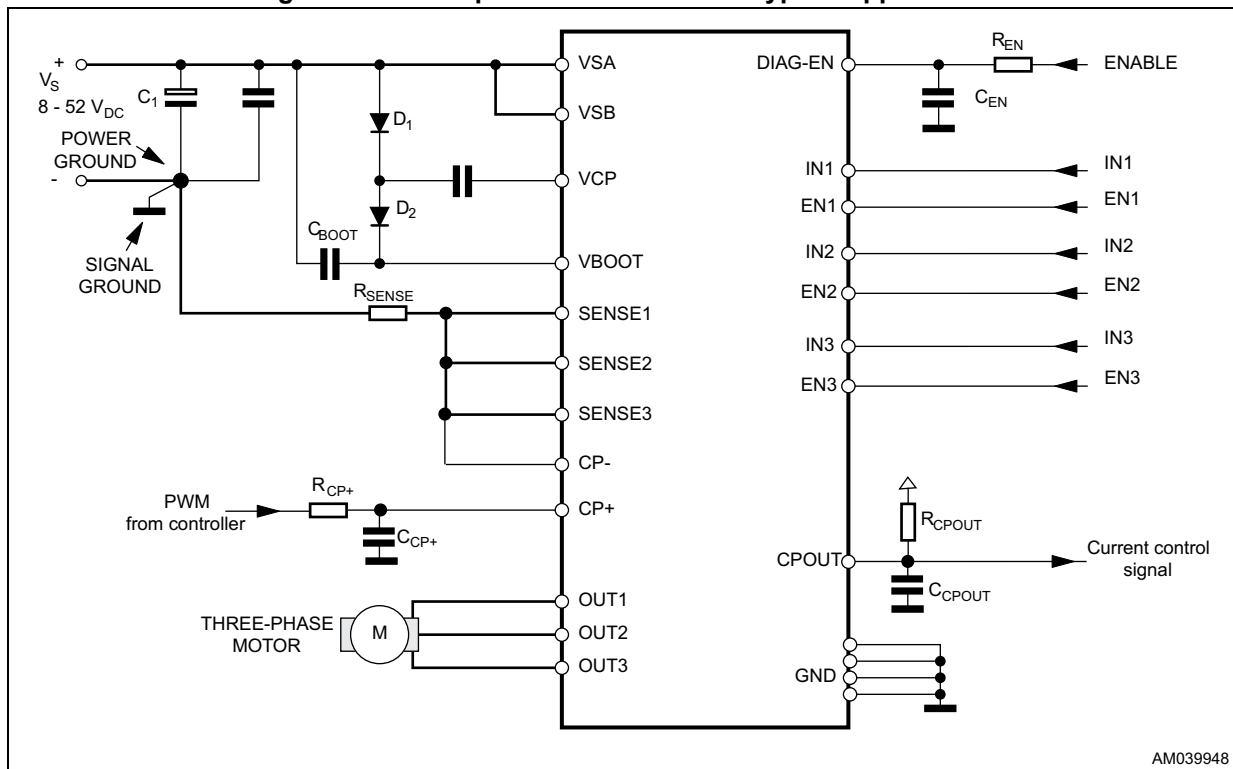

AM039948

6.4 Thermal management

In most applications the power dissipation in the IC is the main factor that sets the maximum current that can be delivered by the device in a safe operating condition. Therefore, it has to be taken into account very carefully. Besides the available space on the PCB, the right package should be chosen considering the power dissipation. Heat-sinking can be achieved using copper on the PCB with a proper area and thickness.

For instance, using a VFQFPN32L 5 x 5 package the typical $R_{th(JA)}$ is about 42 °C/W when mounted on a double-layer FR4 PCB with a dissipating copper area of 0.5 cm² on the top side plus the 6 cm² ground layer connected through 18 via holes (9 below the IC).

Otherwise, using a PowerSO package with a copper slug soldered on a 1.5 mm copper thickness FR4 board with a 6 cm² dissipating footprint (copper thickness of 35 μm), the $R_{th(JA)}$ is about 35°C/W.

Using a multi-layer board with vias to a ground plane, thermal impedance can be reduced down to 15°C/W.

7 Package information

In order to meet environmental requirements, ST offers these devices in different grades of ECOPACK® packages, depending on their level of environmental compliance. ECOPACK® specifications, grade definitions and product status are available at: www.st.com. ECOPACK® is an ST trademark.

7.1 VFQFPN32 package information

Figure 17. VFQFPN 5 x 5 x 1.0, 32 lead, pitch 0.50 package outline

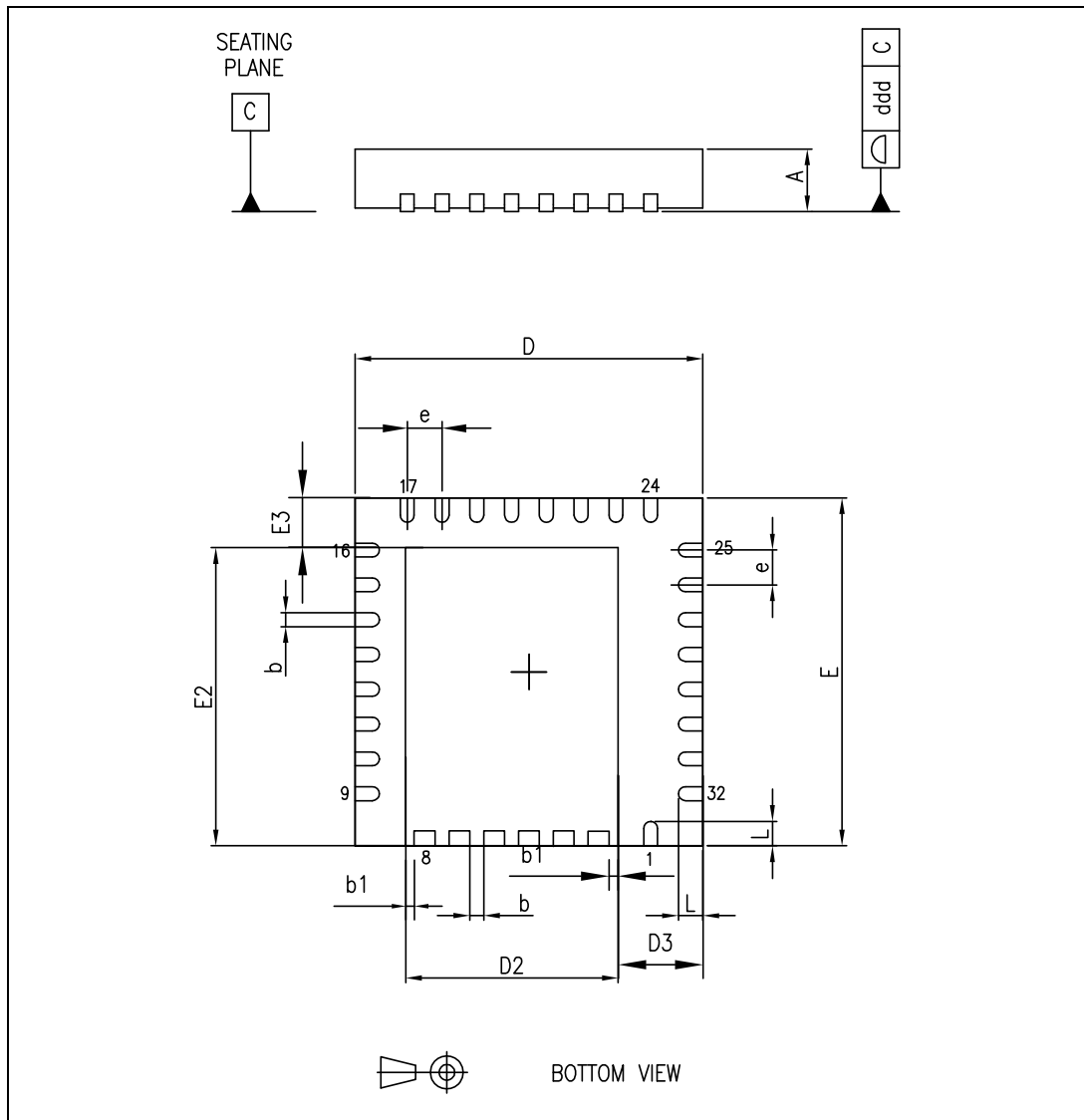

Table 9. VFQFPN 5 x 5 x 1.0, 32 lead, pitch 0.50 package mechanical data

Symbol	Dimensions (mm)		
	Min.	Typ.	Max.
A	0.80	0.85	0.95
b	0.18	0.25	0.30
b1	0.165	0.175	0.185
D	4.85	5.00	5.15
D2	3.00	3.10	3.20
D3	1.10	1.20	1.30
E	4.85	5.00	5.15
E2	4.20	4.30	4.40
E3	0.60	0.70	0.80
e		0.50	
L	0.30	0.40	0.50
ddd			0.08

Note: "VFQFPN" stands for the thermally enhanced very thin profile fine pitch quad flat package no lead. Very thin profile: $0.80 < A < 1.00$ mm.

Details of the terminal 1 are optional but must be located on the top surface of the package by using either a mold or marked features.

7.2 PowerSO36 package information

Figure 18. PowerSO36 package outline

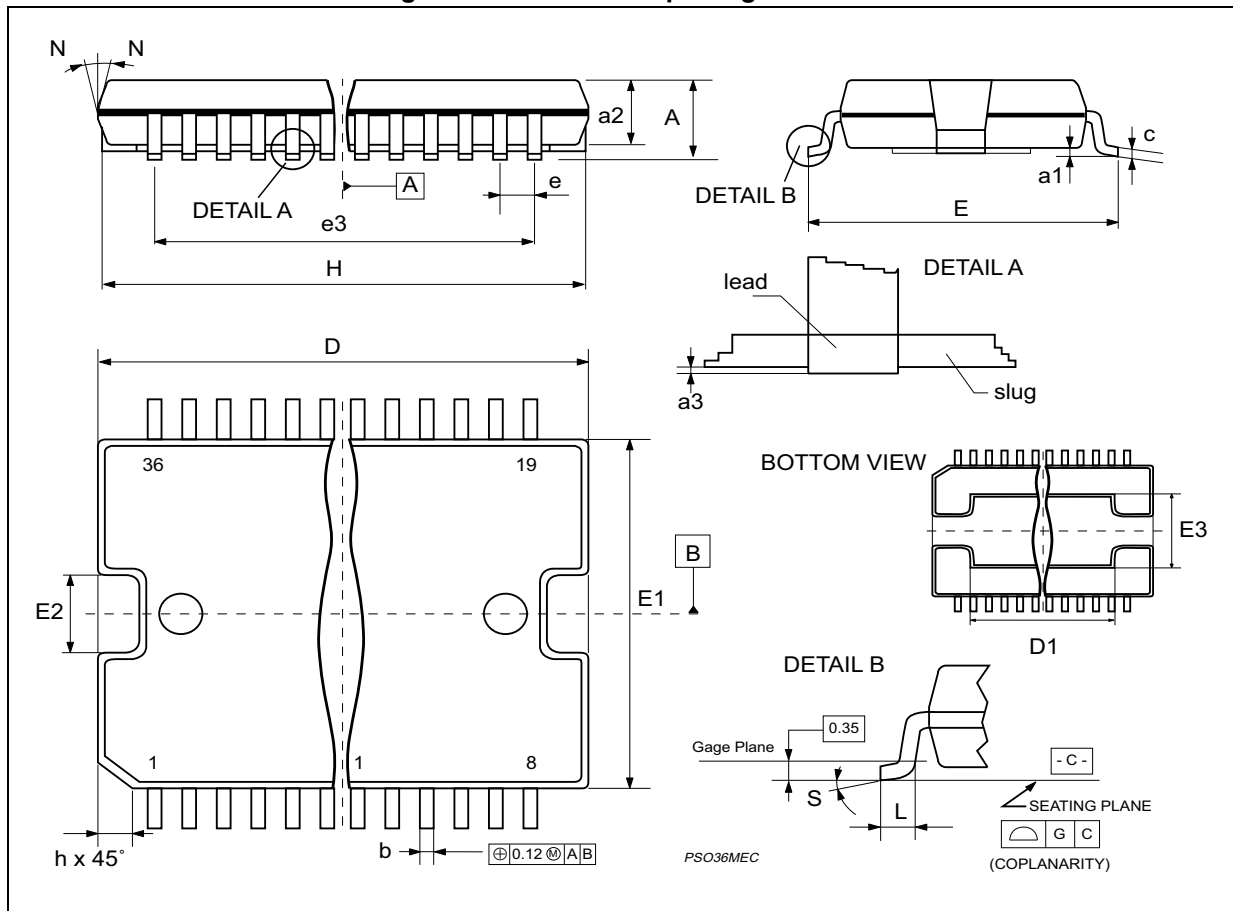

Table 10. PowerSO36 package mechanical data

Symbol	Dimensions (mm)		
	Min.	Typ.	Max.
A			3.6
a1	0.1		0.3
a2			3.3
a3	0		0.1
b	0.22		0.38
c	0.23		0.32
D ⁽¹⁾	15.8		16
D1	9.4		9.8
E	13.9		14.5
e		0.65	
e3		11.05	
E1 ⁽¹⁾	10.9		11.1
E2			2.9
E3	5.8		6.2
E4	2.9		3.2
G	0		0.1
H	15.5		15.9
h			1.1
L	0.8		1.1
N	10°(max.)		
S	8 °(max.)		

1. "D" and "E1" do not include mold flash or protrusions:
 - Mold flash or protrusions shall not exceed 0.15 mm
 - Critical dimensions are "a3", "E" and "G".

8 Revision history

Table 11. Document revision history

Date	Revision	Changes
14-Oct-2010	1	First release
07-Jun-2011	2	Updated maturity status from preliminary data to final datasheet.
01-Aug-2016	3	<p>Updated Figure 1 on page 3 (replaced by new figure).</p> <p>Updated Table 2 on page 4 and Table 3 on page 4 (corrected SENSE pin labels).</p> <p>Updated Figure 2 on page 6, Figure 3 on page 6, Figure 10 on page 13, Section 5.3 on page 13, and Figure 14 on page 16 to Figure 16 on page 18 (replaced "DIAG/EN" by "DIAG-EN").</p> <p>Added cross-reference to Table 5 on page 7 in Section 6 on page 15, to Section 5.3 on page 13 in Section 5.2 on page 12 and in Section 6 on page 15.</p> <p>Updated Section 6.2 on page 17 (several updates).</p> <p>Replaced "DIAG/EN" by "DIAG-EN" in whole document.</p> <p>Minor modifications throughout document.</p>

IMPORTANT NOTICE – PLEASE READ CAREFULLY

STMicroelectronics NV and its subsidiaries (“ST”) reserve the right to make changes, corrections, enhancements, modifications, and improvements to ST products and/or to this document at any time without notice. Purchasers should obtain the latest relevant information on ST products before placing orders. ST products are sold pursuant to ST’s terms and conditions of sale in place at the time of order acknowledgement.

Purchasers are solely responsible for the choice, selection, and use of ST products and ST assumes no liability for application assistance or the design of Purchasers’ products.

No license, express or implied, to any intellectual property right is granted by ST herein.

Resale of ST products with provisions different from the information set forth herein shall void any warranty granted by ST for such product.

ST and the ST logo are trademarks of ST. All other product or service names are the property of their respective owners.

Information in this document supersedes and replaces information previously supplied in any prior versions of this document.

© 2016 STMicroelectronics – All rights reserved