



Chipsmall Limited consists of a professional team with an average of over 10 year of expertise in the distribution of electronic components. Based in Hongkong, we have already established firm and mutual-benefit business relationships with customers from,Europe,America and south Asia,supplying obsolete and hard-to-find components to meet their specific needs.

With the principle of “Quality Parts,Customers Priority,Honest Operation,and Considerate Service”,our business mainly focus on the distribution of electronic components. Line cards we deal with include Microchip,ALPS,ROHM,Xilinx,Pulse,ON,Everlight and Freescale. Main products comprise IC,Modules,Potentiometer,IC Socket,Relay,Connector.Our parts cover such applications as commercial,industrial, and automotives areas.

We are looking forward to setting up business relationship with you and hope to provide you with the best service and solution. Let us make a better world for our industry!



Contact us

Tel: +86-755-8981 8866 Fax: +86-755-8427 6832

Email & Skype: info@chipsmall.com Web: www.chipsmall.com

Address: A1208, Overseas Decoration Building, #122 Zhenhua RD., Futian, Shenzhen, China



0.5 A high side driver intelligent power switch

Features

- 0.5 A output current
- 8 V to 35 V supply voltage range
- Internal current limiting
- Thermal shutdown
- Open ground protection
- Internal negative voltage clamping for fast demagnetization
- Differential inputs with large common mode range and threshold hysteresis
- Undervoltage lockout with hysteresis
- Open load detection
- Two diagnostic outputs
- Output status LED driver
- Non-dissipative short-circuit protection
- Immunity against burst transient (IEC 61000-4-4)
- ESD protection (human body model ± 2 kV)

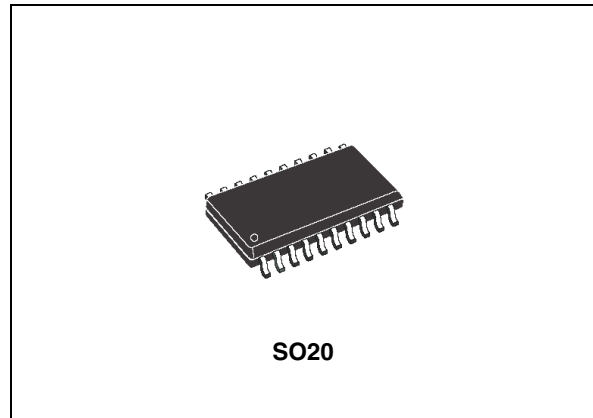

Description

The L6375D is a monolithic intelligent power switch in BCDmultipower technology, for driving inductive or resistive loads with controlled output voltage slew rate and short-circuit protection.

An internal clamping diode enables the fast demagnetization of inductive loads. Diagnostics for CPU feedback and extensive use of electrical protection make this device extremely rugged and specially suitable for industrial automation applications.

Table 1. Device summary

Order codes	Op. temp. range	Package	Packaging
L6375D	-25 to +125 °C	SO20	Tube
L6375DTR			Tape and reel

Contents

1	Block diagram and pin description	3
1.1	Pin description	4
2	Electrical specifications	5
2.1	Absolute maximum ratings	5
2.2	Thermal data	5
2.3	Electrical characteristics	6
2.4	Switching waveform	8
2.5	Input section	8
2.6	Overtemperature protection (OVT)	8
2.7	Undervoltage protection (UV)	8
2.8	Overcurrent operation	9
2.9	Diagnostic logic	10
2.10	Demagnetization of inductive loads	10
2.11	Diagnostic truth table	10
3	Application circuits	11
4	Package mechanical data	13
5	Revision history	15

1 Block diagram and pin description

Figure 1. Block diagram

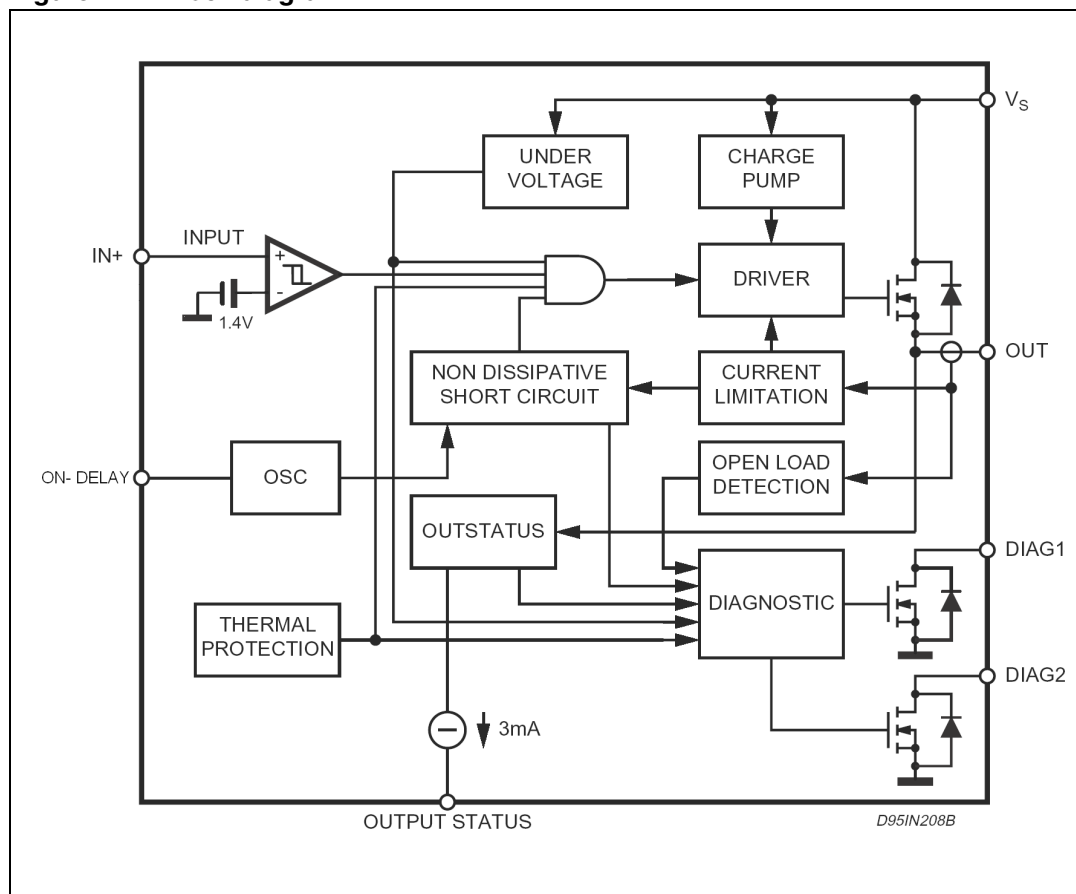
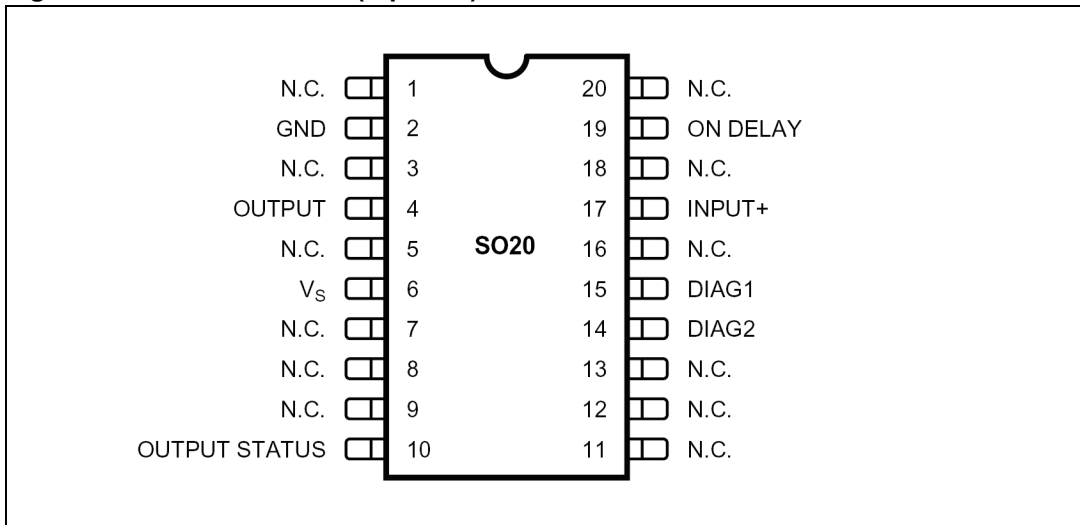

Figure 2. Pin connection (top view)



1.1 Pin description

Table 2. Pin description

Pin n°	Pin name	Function
2	GND	Ground
4	OUT	High side output with built-in current limitation
6	V _S	Supply voltage input; the value of the supply voltage is monitored to detect undervoltage condition
10	Output status	This current source output is capable of driving an LED to signal the status of the output pin. The pin is active (source current) when the output pin is considered high (see Figure 4)
15	DIAG1	DIAGNOSTIC 1 output. This open drain reports the IC working conditions (see Table 6: Diagnostic truth table)
14	DIAG2	DIAGNOSTIC 2 output. This open drain reports the IC working conditions (see Table 6: Diagnostic truth table)
17	IN+	Comparator inverting input
19	ON-DELAY	Programmable ON time interval duration during short-circuit operation
1, 3, 5, 7, 8, 9, 11, 12, 13, 16, 18, 20	N.C.	Not connected

2 Electrical specifications

2.1 Absolute maximum ratings

Table 3. Absolute maximum ratings

Symbol	Parameter	Value	Unit
V_S	Supply voltage (tw < 10 ms)	50	V
V_S	Supply voltage (DC)	40	V
$V_S - V_{out}$	Supply to output differential voltage	Internally limited	V
V_{od}	Externally forced voltage	-0.3 to 7	V
I_{od}	Externally forced current	± 1	mA
I_{out}	Output current (see also I_{sc})	Internally limited	A
V_{out}	Output voltage	Internally limited	V
P_{TOT}	Power dissipation	Internally limited	W
V_{diag}	External voltage	-0.3 to 40	V
I_{diag}	Externally forced current	-10 to 10	mA
I_i	Input current	20	mA
V_i	Input voltage	-10 to $V_S + 0.3$	V
T_{op}	Ambient temperature, operating range	-25 to 85	°C
T_J	Junction temperature, operating range (see Section 2.6)	-25 to 125	°C
T_{STG}	Storage temperature	-55 to 150	°C
E_I	Energy inductive load $T_J = 85$ °C	200	mJ

2.2 Thermal data

Table 4. Thermal data

Symbol	Parameter	Value	Unit
R_{thJA}	Thermal resistance junction-ambient max. ⁽¹⁾	65	°C/W
R_{thJP}	Thermal resistance junction-pins max.	15	°C/W

1. When mounted on an FR4 printed circuit board with 0.5 cm² of Cu (at least 35 mm thick).

2.3 Electrical characteristics

$V_S = 24\text{ V}$; $T_J = -25\text{ to }+125\text{ }^\circ\text{C}$, unless otherwise specified.

Table 5. Electrical characteristics

Symbol	Parameter	Test condition	Min.	Typ.	Max.	Unit
V_{smin}	Supply voltage for valid diagnostic	$I_{diag} = > 0.5\text{ mA}$; $V_{diag} = 1.5\text{ V}$;	4		35	V
V_S	Operative supply voltage		8	24	35	V
V_{sth1}	Undervoltage threshold 1		7	7.5	8	V
V_{sth2}	Undervoltage threshold 2		6.5	7	7.5	V
V_{shys}	Undervoltage hysteresis		300	500	700	mV
I_q	Quiescent current	Output open		800		μA
I_{qo}	Quiescent current	Output ON		1.6		mA
V_{ith}	Input threshold voltage		0.8	1.3	2	V
V_{iths}	Input threshold hysteresis		50		400	mV
V_{il}	Input low level voltage		-7		0.8	V
V_{ih}	Input high level voltage	$V_S < 18\text{ V}$	2		$V_S - 3$	V
V_{ih}	Input high level voltage	$V_S > 18\text{ V}$	2		15	V
I_{ib}	Input bias current	$V_i = -7\text{ to }15\text{ V}$	-250		250	μA
I_{dch}	Delay capacitor charging current	ON DELAY pin shorted to ground		2.5		μA
V_{don}	Output voltage drop	$I_{out} = 500\text{ mA } T_J = 25\text{ }^\circ\text{C}$ $T_J = 125\text{ }^\circ\text{C}$ $I_{out} = 625\text{ mA } T_J = 25\text{ }^\circ\text{C}$ $T_J = 125\text{ }^\circ\text{C}$		200 320 250 400	280 440 350 550	mV mV mV mV
I_{olk}	Output leakage current	$V_i = \text{LOW}; V_{out} = 0$			100	μA
V_{ol}	Output low state voltage	$V_i = \text{HIGH}; \text{pin floating}$		0.8	1.5	V
V_{cl}	Internal voltage clamp ($V_S - V_{out}$)	$I_o = 200\text{ mA}$ single pulsed = 300 ms	48	53	58	V
I_{sc}	Short-circuit output current	$V_S = 8\text{ to }35\text{ V}; R_l = 2\text{ }\Omega$;	0.75	1.1	1.5	A
I_{old}	Open load detection current	$V_i = V_{ih}; T_A = 0\text{ to }+85\text{ }^\circ\text{C}$	1	3	6	mA
V_{oth1}	Output status threshold 1 voltage		4.5	5	5.5	V
V_{oth2}	Output status threshold 2 voltage		4	4.5	5	V
V_{ohys}	Output status threshold hysteresis		300	500	700	mV
I_{osd}	Output status source current	$V_{out} > V_{oth1}; V_{os} = 2.5\text{ V}$	2		4	mA

Table 5. Electrical characteristics (continued)

Symbol	Parameter	Test condition	Min.	Typ.	Max.	Unit
V_{osd}	Active output status driver drop voltage	$V_S - V_{OS}$; $I_{OS} = 2 \text{ mA}$ $T_A = 0 \text{ to } +85 \text{ }^\circ\text{C}$		1.5	3	V
I_{oslk}	Output status driver leakage current	$V_{out} < V_{oth2}$; $V_{os} = 0 \text{ V}$ $V_S = 18 \text{ to } 35 \text{ V}$			25	mA
V_{dgl}	Diagnostic drop voltage	D1 / D2 = L; $I_{diag} = 0.5 \text{ mA}$ D1 / D2 = L; $I_{diag} = 3 \text{ mA}$		40 250		mV mV
I_{dglk}	Diagnostic leakage current	D1 / D2 = H; $0 < V_{dg} < V_S$ $V_S = 15.6 \text{ to } 35 \text{ V}$			5	μA
T_{max}	Overtemperature upper threshold			150		$^\circ\text{C}$
T_{hys}	Overtemperature hysteresis			20		$^\circ\text{C}$
AC operation (pin numbering referred to Minidip package)						
$t_r - t_f$	Rise or fall time	$V_S = 24 \text{ V}$; $R_I = 70 \text{ } \Omega$ R_I to ground		20		μs
t_d	Delay time	$V_S = 24 \text{ V}$; $R_I = 70 \text{ } \Omega$ R_I to ground		5		μs
dV/dt	Slew-rate (rise and fall edge)		0.7	1	1.5	V/ μs
t_{ON}	ON time during short-circuit condition	$50 \text{ pF} < C_{DON} < 2 \text{ nF}$		1.28		$\mu\text{s/pF}$
t_{OFF}	OFF time during short-circuit condition			64		t_{ON}
f_{max}	Maximum operating frequency			25		KHz
Source drain NDMOS diode						
V_f	Forward ON voltage	@ $I_{fsd} = 625 \text{ mA}$		1	1.5	V
I_{fD}	Forward peak voltage	$t = 10 \text{ ms}$; $d = 20\%$			2	A
t_{rr}	Reverse recovery time	$I_f = 625 \text{ mA}$ $di/dt = 25 \text{ A/ms}$		200		ns
t_{fr}	Forward recovery time			50		ns

2.4 Switching waveform

Figure 3. Switching waveform

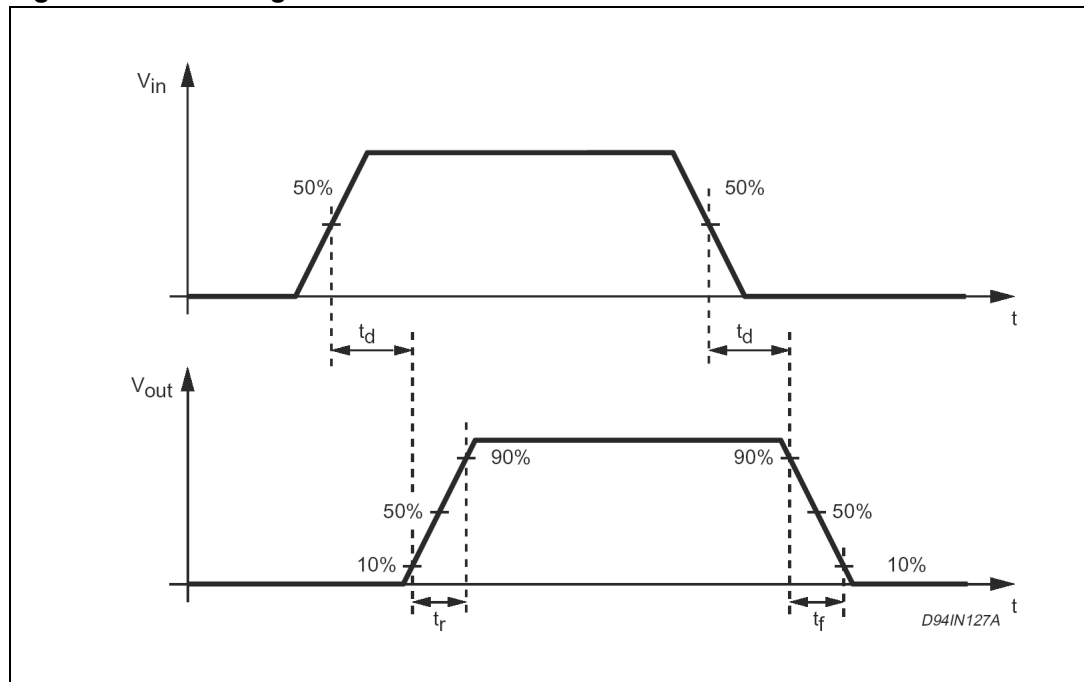

2.5 Input section

A single ended input TTL/CMOS compatible with a wide voltage range and high noise immunity (thanks to a built-in hysteresis) is available.

2.6 Overtemperature protection (OVT)

An on-chip overtemperature protection provides excellent protection of the device in extreme conditions. Whenever the temperature, measured on a central portion of the chip, exceeds $T_{max} = 150\text{ °C}$ (typical value), the device is shut off, and the DIAG2 output goes LOW. Normal operation is resumed as the chip temperature (normally after a few seconds) falls below $T_{max} - T_{hys} = 130\text{ °C}$ (typical value). The hysteresis avoids that an intermittent behavior takes place.

2.7 Undervoltage protection (UV)

The supply voltage is expected to range from 8 to 35 V. In this range the device operates correctly. To avoid any malfunctioning the supply voltage is continuously monitored to provide an undervoltage protection. As V_S falls below $V_{sth} - V_{shys}$ (typically 7.5 V, see [Figure 1](#)) the output Power MOSFET is switched off and DIAG1 and DIAG2 (see [Section 2.11](#)). Normal operation is resumed as soon as V_S exceeds V_{sth} . The hysteretic behavior prevents intermittent operation at low supply voltage.

2.8 Overcurrent operation

In order to implement a short-circuit protection the output Power MOSFET is driven in linear mode to limit the output current to the I_{sc} (1.1 A typical value). This condition (current limited to the I_{sc} value) lasts for a T_{on} time interval, that can be set by means of a capacitor (C_{don}) connected to the ON DELAY pin according to the following formula:

$$T_{on} = 1.28 \mu\text{sec} / \text{pF}$$

for

$$50 \text{ pF} < C_{don} < 2 \text{ nF}$$

After the T_{on} interval has expired the output Power MOSFET is switched off for the T_{off} time interval with:

$$T_{off} = 64 \cdot T_{on}$$

When also the T_{off} interval has expired, the output Power MOSFET is switched ON. At this point in time two conditions may occur

- The overload is still present, and then the output Power MOSFET is again driven in linear mode (limiting the output current to I_{sc}) for another T_{on} , starting a new cycle, or
- the overload condition is removed, and the output Power MOSFET is no longer driven in linear mode. All these occurrences are presented on the DIAG2 pin (see [Figure 2](#)).

This unique feature is called non-dissipative short-circuit protection and it ensures a very safe operation even in permanent overload conditions. Note that choosing the most appropriate value for the T_{on} interval (i.e. the value of the C_{don} capacitor) a delay (the T_{on} itself) prevents that misleading short-circuit information is presented on the DIAG2 output, when driving capacitive loads (that acts as a short-circuit in the very beginning) or incandescent lamp (a cold filament has a very low resistive value). The non-dissipative short-circuit protection can be disabled (keeping $T_{on} = 0$ but with the output current still limited to I_{sc} , and diagnostic disabled) simply shorting to ground the ON DELAY pin.

Figure 4. Non-dissipative short-circuit protection operation

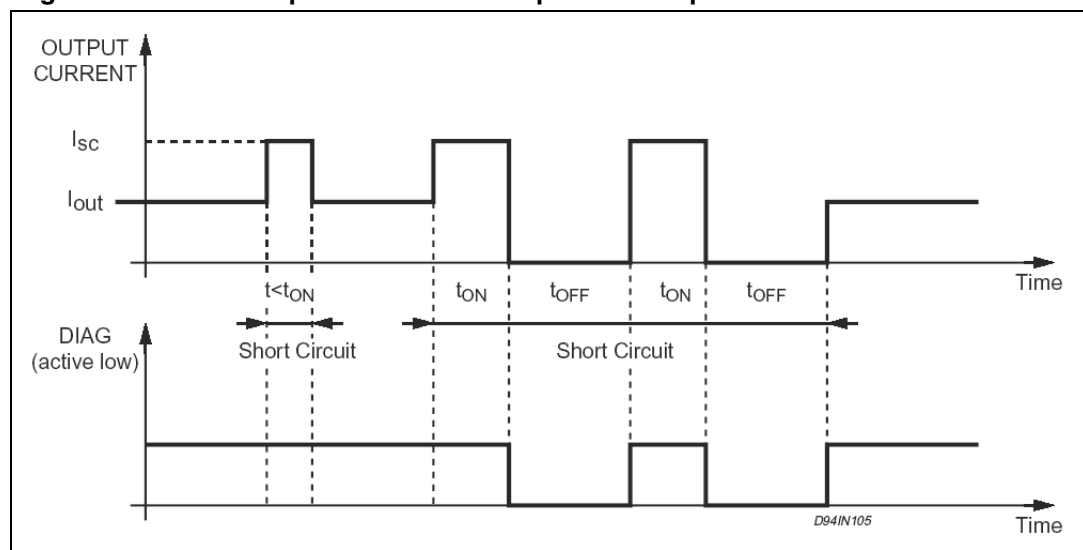

2.9 Diagnostic logic

The operating conditions of the device are permanently monitored and the following occurrences are signalled via the DIAG1/DIAG2 open drain output pins, see [Table 6: Diagnostic truth table](#).

- Short-circuit vs. ground
- Short-circuit vs. VS
- Undervoltage (UV)
- Overtemperature (OVT)
- Open load, if the output current is less than 3 mA (typical value).

2.10 Demagnetization of inductive loads

An internal Zener diode, limiting the voltage across the Power MOSFET to between 50 and 60 V (V_{cl}), provides safe and fast demagnetization of inductive loads without external clamping devices. The maximum energy that can be absorbed from an inductive load is specified as 200 mJ (at $T_J = 85\text{ °C}$).

2.11 Diagnostic truth table

Table 6. Diagnostic truth table

Diagnostic conditions	Input	Output	Diag1	Diag2
Normal operation	L	L	H	H
	H	H	H	H
Open load condition ($I_o < I_{old}$)	L	L	H	H
	H	H	L	H
Short to V_S	L	H	L	H
	H	H	L	H
Short-circuit to ground ($I_O = I_{sc}$) ⁽¹⁾ (pin ON-DELAY grounded)	H	X	H	H
	L	L	H	H
Output DMOS open	L	L	H	H
	H	L	L	H
Overtemperature	L	L	H	L
	H	L	H	L
Supply undervoltage ($V_S < V_{sth2}$)	L	L	L	L
	H	L	L	L

1. A cold lamp filament, or a capacitive load may activate the current limiting circuit of the IPS, when the IPS is initially turned on.

3 Application circuits

Figure 5. Inductive load equivalent circuit

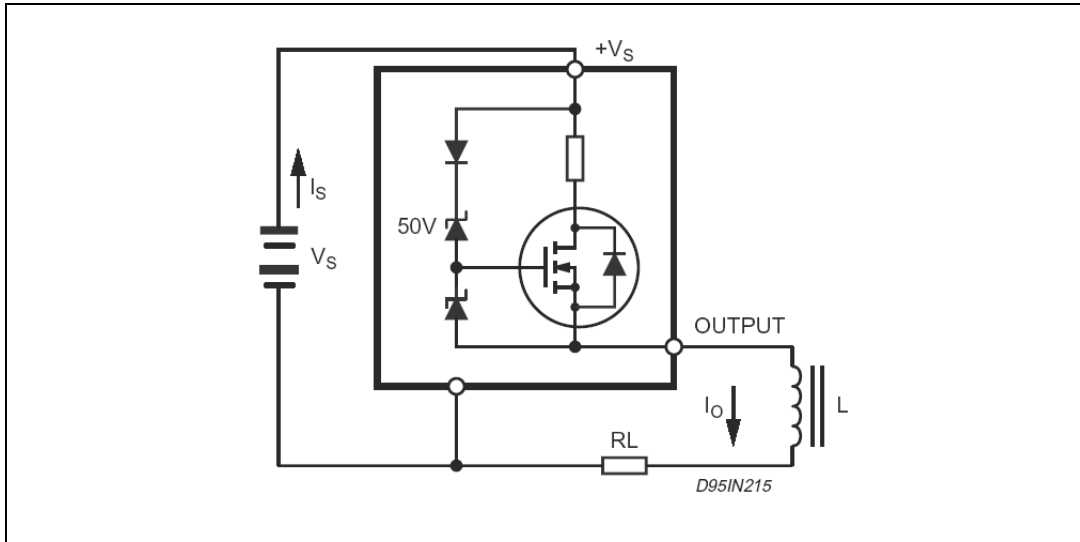

Figure 6. External demagnetization circuit (vs. ground)

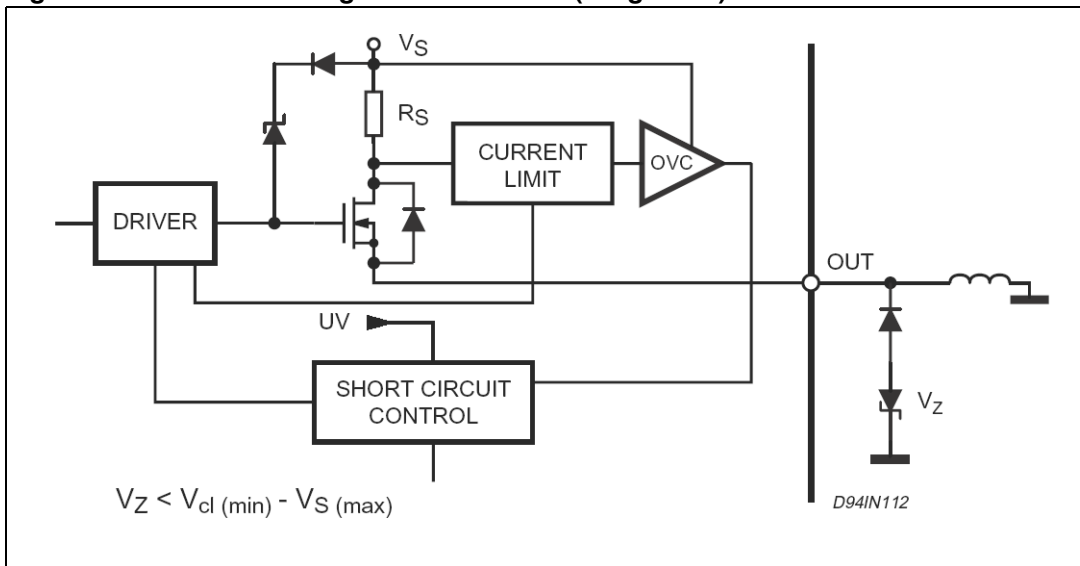

Figure 7. External demagnetization circuit (vs. VS)

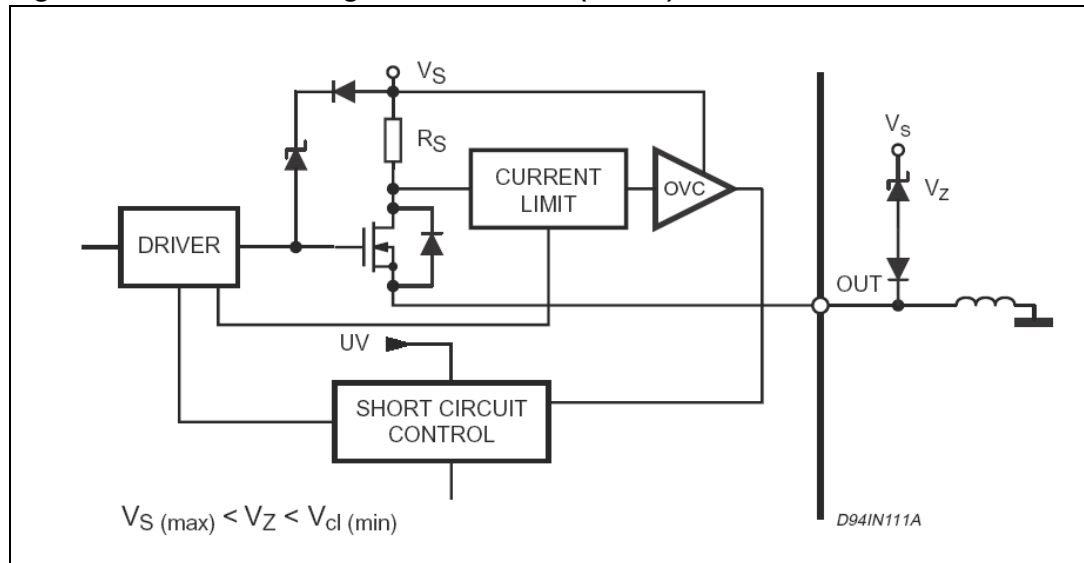
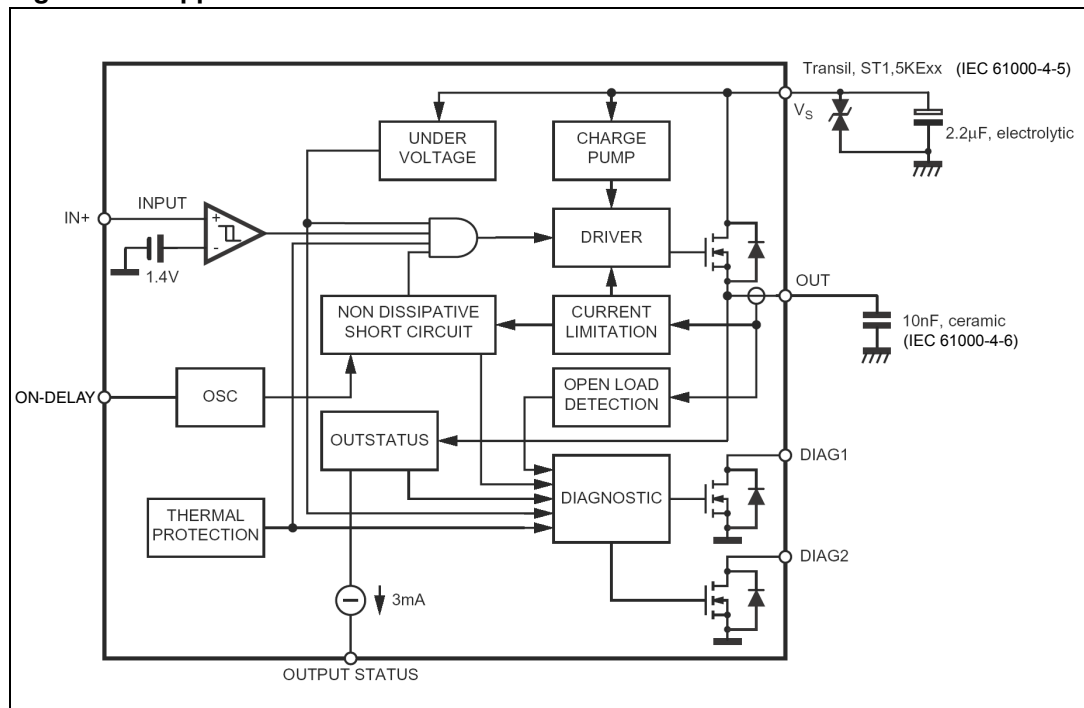

Figure 8. Application schematic



4 Package mechanical data

In order to meet environmental requirements, ST offers these devices in different grades of ECOPACK® packages, depending on their level of environmental compliance. ECOPACK specifications, grade definitions and product status are available at: www.st.com. ECOPACK is an ST trademark.

Table 7. SO20 mechanical data

Dim.	mm			inch		
	Min.	Typ.	Max.	Min.	Typ.	Max.
A	2.35		2.65	0.093		0.104
A1	0.1		0.3	0.004		0.012
B	0.33		0.51	0.013		0.020
C	0.23		0.32	0.009		0.013
D	12.6		13	0.496		0.512
E	7.4		7.6	0.291		0.299
e		1.27			0.050	
H	10		10.65	0.394		0.419
h	0.25		0.75	0.010		0.030
L	0.4		1.27	0.016		0.050
K	0° (min.)8° (max.)					

Figure 9. Package dimensions

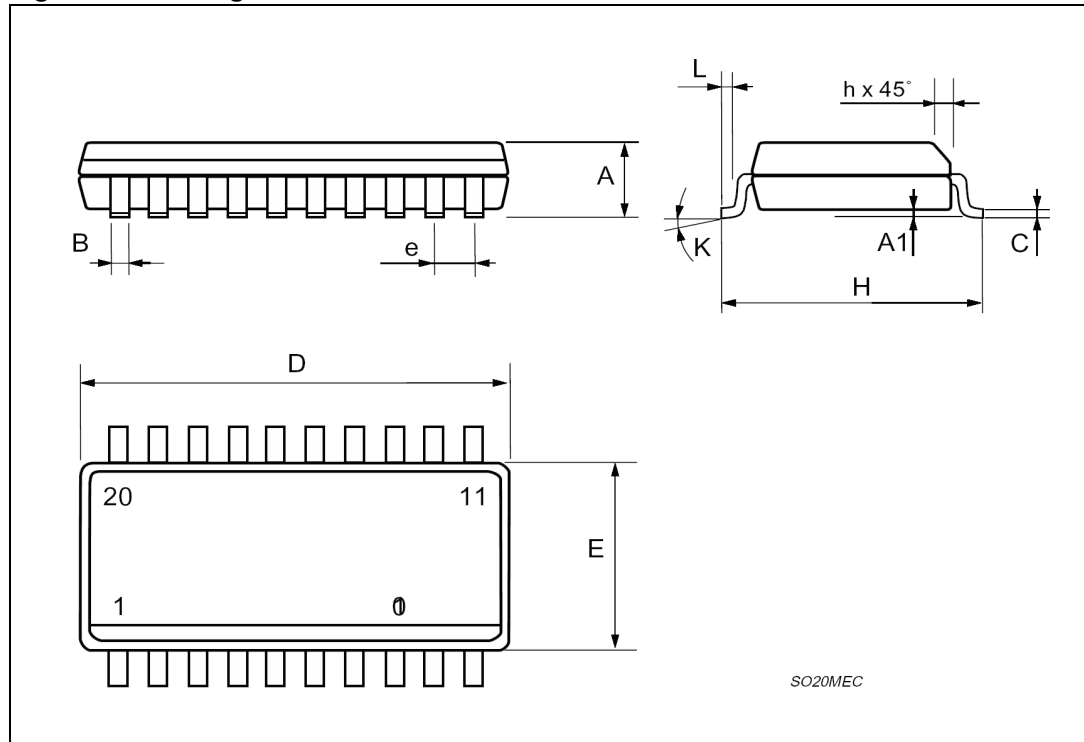

5 Revision history

Table 8. Document revision history

Date	Revision	Changes
24-Jul-2007	1	Initial release
29-Jun-2009	2	Updated Table 5 on page 7
21-Dec-2011	3	Updated Table 5 on page 7

Please Read Carefully:

Information in this document is provided solely in connection with ST products. STMicroelectronics NV and its subsidiaries ("ST") reserve the right to make changes, corrections, modifications or improvements, to this document, and the products and services described herein at any time, without notice.

All ST products are sold pursuant to ST's terms and conditions of sale.

Purchasers are solely responsible for the choice, selection and use of the ST products and services described herein, and ST assumes no liability whatsoever relating to the choice, selection or use of the ST products and services described herein.

No license, express or implied, by estoppel or otherwise, to any intellectual property rights is granted under this document. If any part of this document refers to any third party products or services it shall not be deemed a license grant by ST for the use of such third party products or services, or any intellectual property contained therein or considered as a warranty covering the use in any manner whatsoever of such third party products or services or any intellectual property contained therein.

UNLESS OTHERWISE SET FORTH IN ST'S TERMS AND CONDITIONS OF SALE ST DISCLAIMS ANY EXPRESS OR IMPLIED WARRANTY WITH RESPECT TO THE USE AND/OR SALE OF ST PRODUCTS INCLUDING WITHOUT LIMITATION IMPLIED WARRANTIES OF MERCHANTABILITY, FITNESS FOR A PARTICULAR PURPOSE (AND THEIR EQUIVALENTS UNDER THE LAWS OF ANY JURISDICTION), OR INFRINGEMENT OF ANY PATENT, COPYRIGHT OR OTHER INTELLECTUAL PROPERTY RIGHT.

UNLESS EXPRESSLY APPROVED IN WRITING BY TWO AUTHORIZED ST REPRESENTATIVES, ST PRODUCTS ARE NOT RECOMMENDED, AUTHORIZED OR WARRANTED FOR USE IN MILITARY, AIR CRAFT, SPACE, LIFE SAVING, OR LIFE SUSTAINING APPLICATIONS, NOR IN PRODUCTS OR SYSTEMS WHERE FAILURE OR MALFUNCTION MAY RESULT IN PERSONAL INJURY, DEATH, OR SEVERE PROPERTY OR ENVIRONMENTAL DAMAGE. ST PRODUCTS WHICH ARE NOT SPECIFIED AS "AUTOMOTIVE GRADE" MAY ONLY BE USED IN AUTOMOTIVE APPLICATIONS AT USER'S OWN RISK.

Resale of ST products with provisions different from the statements and/or technical features set forth in this document shall immediately void any warranty granted by ST for the ST product or service described herein and shall not create or extend in any manner whatsoever, any liability of ST.

ST and the ST logo are trademarks or registered trademarks of ST in various countries.

Information in this document supersedes and replaces all information previously supplied.

The ST logo is a registered trademark of STMicroelectronics. All other names are the property of their respective owners.

© 2011 STMicroelectronics - All rights reserved

STMicroelectronics group of companies

Australia - Belgium - Brazil - Canada - China - Czech Republic - Finland - France - Germany - Hong Kong - India - Israel - Italy - Japan - Malaysia - Malta - Morocco - Philippines - Singapore - Spain - Sweden - Switzerland - United Kingdom - United States of America

www.st.com