



Chipsmall Limited consists of a professional team with an average of over 10 year of expertise in the distribution of electronic components. Based in Hongkong, we have already established firm and mutual-benefit business relationships with customers from,Europe,America and south Asia,supplying obsolete and hard-to-find components to meet their specific needs.

With the principle of "Quality Parts,Customers Priority,Honest Operation,and Considerate Service",our business mainly focus on the distribution of electronic components. Line cards we deal with include Microchip,ALPS,ROHM,Xilinx,Pulse,ON,Everlight and Freescale. Main products comprise IC,Modules,Potentiometer,IC Socket,Relay,Connector.Our parts cover such applications as commercial,industrial, and automotives areas.

We are looking forward to setting up business relationship with you and hope to provide you with the best service and solution. Let us make a better world for our industry!



## Contact us

Tel: +86-755-8981 8866 Fax: +86-755-8427 6832

Email & Skype: info@chipsmall.com Web: www.chipsmall.com

Address: A1208, Overseas Decoration Building, #122 Zhenhua RD., Futian, Shenzhen, China





# L6725 L6725A

## Voltage mode PWM controller with bootstrap anti-discharging system

### Features

- Input voltage range from 1.8V to 18V
- Supply voltage range from 4.5V to 18V
- Adjustable output voltage down to 0.6V with  $\pm 0.8\%$  accuracy over line voltage and temperature ( $0^{\circ}\text{C} \sim 125^{\circ}\text{C}$ )
- Fixed frequency voltage mode control
- 0% to 100% duty cycle
- External input voltage reference
- Soft-start and inhibit
- Bootstrap anti-discharging system
- High current embedded drivers
- Predictive anti-cross conduction control
- Programmable high-side and low-side  $R_{\text{DS(on)}}$  sense over-current-protection
- Sink current capability
- Selectable switching frequency 250KHz/500KHz
- Power good and synch available with L6725A
- Pre-bias start up capability
- Over voltage protection
- Thermal shut-down
- Package: SO16N

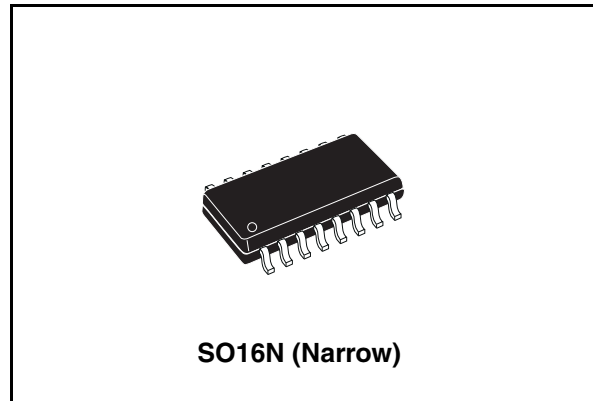

### Applications

- Low voltage distributed DC-DC
- Graphic cards

Table 1. Device summary

| Order codes | Package | Packing     |
|-------------|---------|-------------|
| L6725       | SO16N   | Tube        |
| L6725TR     | SO16N   | Tape & Reel |
| L6725A      | SO16N   | Tube        |
| L6725ATR    | SO16N   | Tape & Reel |

# Contents

|          |  |           |
|----------|--|-----------|
| <b>1</b> | <b>Summary description</b> .....                               | <b>4</b>  |
| 1.1      | Functional description .....                                   | 4         |
| <b>2</b> | <b>Electrical data</b> .....                                   | <b>5</b>  |
| 2.1      | Maximum rating .....   | 5         |
| 2.2      | Thermal data .....   | 5         |
| <b>3</b> | <b>Pin connections and functions</b> .....                     | <b>6</b>  |
| <b>4</b> | <b>Electrical characteristics</b> .....                        | <b>8</b>  |
| <b>5</b> | <b>Device description</b> .....                                | <b>10</b> |
| 5.1      | Oscillator .....   | 10        |
| 5.2      | Internal LDO .....   | 10        |
| 5.3      | Bypassing the LDO to avoid the voltage drop with low Vcc ..... | 11        |
| 5.4      | Internal and external references .....                         | 11        |
| 5.5      | Error amplifier .....  | 12        |
| 5.6      | Soft start .....   | 12        |
| 5.7      | Driver section .....   | 14        |
| 5.8      | Monitoring and protections .....                               | 14        |
| 5.9      | Hiccup mode .....  | 15        |
| 5.10     | Thermal shutdown .....   | 15        |

---

|          |   |           |
|----------|---|-----------|
| 5.11     | Synchronization .....                   | 16        |
| 5.12     | Bootstrap anti-discharging system ..... | 17        |
| 5.12.1   | Fan's power supply .....                | 17        |
| <b>6</b> | <b>Application details .....</b>        | <b>18</b> |
| 6.1      | Inductor design .....                   | 18        |
| 6.2      | Output capacitors .....                 | 19        |
| 6.3      | Input capacitors .....                  | 19        |
| 6.4      | Compensation network .....              | 20        |
| <b>7</b> | <b>L6725 demoboard .....</b>            | <b>22</b> |
| 7.1      | 20A board description .....             | 22        |
| 7.2      | 5A board description .....              | 26        |
| <b>8</b> | <b>Package mechanical data .....</b>    | <b>29</b> |
| <b>9</b> | <b>Revision history .....</b>           | <b>31</b> |

# 1 Summary description

The device is a flexible high performance PWM buck controller dedicated for low voltage distributed DC-DC. The input voltage can range from 1.8V to 18V, while the supply voltage can range from 4.5V to 18V. The output voltage is adjustable down to 0.6V.

High peak current gate drivers provide for fast switching to the external power section, and the output current can be in excess of 20A. The device is capable to manage minimum on-times ( $T_{ON}$ ) shorter than 100ns making possible conversions with very low duty cycle and very high switching frequency. In order to guarantee a real overcurrent protection, also with very narrow  $T_{ON}$ , the current sense is realized both on the high-side and low-side MOSFETs. When necessary, two different current limit protections can be externally set through an external resistor. The device can sink current after the soft-start phase while, during the soft-start, the sink mode capability is disabled in order to allow a proper start-up also in pre-biased output voltage conditions. Other features are over-voltage-protection and thermal shutdown.

## 1.1 Functional description

Figure 1. Block diagram

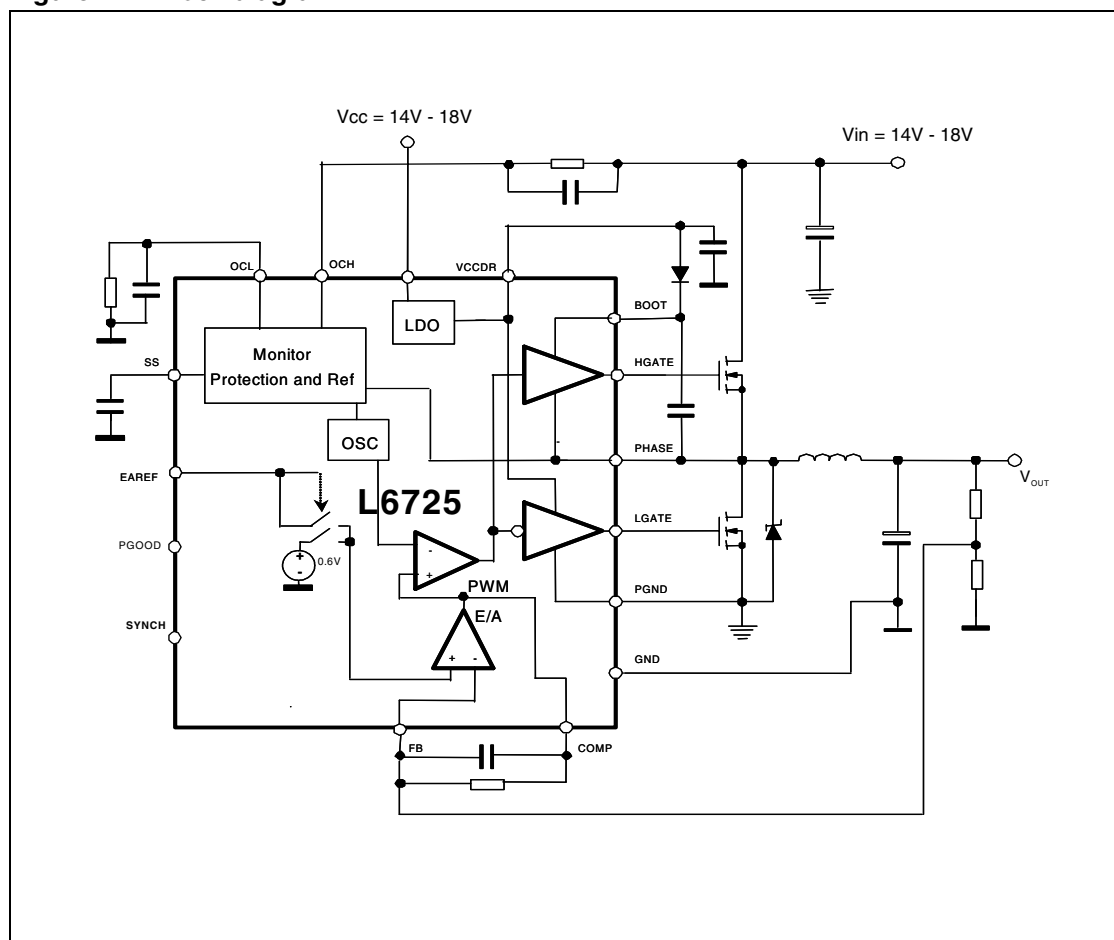

## 2 Electrical data

### 2.1 Maximum rating

Table 2. Absolute maximum ratings

| Symbol                  | Parameter  | Value                       | Unit |
|-------------------------|--|-----------------------------|------|
| $V_{CC}$                | $V_{CC}$ to GND and PGND, OCH  | -0.3 to 20                  | V    |
| $V_{BOOT} - V_{PHASE}$  | Boot voltage   | 0 to 6                      | \    |
| $V_{HGATE} - V_{PHASE}$ |  | 0 to $V_{BOOT} - V_{PHASE}$ | V    |
| $V_{BOOT}$              | BOOT   | -0.3 to 26                  | V    |
| $V_{PHASE}$             | PHASE  | -1 to 20                    | V    |
|                         | PHASE Spike, transient < 50ns ( $F_{SW} = 500\text{KHz}$ )                                       | -3                          |      |
|                         |  | +24                         |      |
|                         | SS, FB, EAREF, OCL, LGATE, COMP, $V_{CCDR}$  | -0.3 to 6                   | V    |
| OCH Pin                 | Maximum withstanding voltage range   | $\pm 1500$                  | V    |
| OTHER PINS              | Test Condition: CDF-AEC-Q100-002 "Human Body Model"<br>Acceptance Criteria: "Normal Performance" | $\pm 2000$                  |      |

### 2.2 Thermal data

Table 3. Thermal data

| Symbol           | Description                                 | Value      | Unit                        |
|------------------|---|------------|-----------------------------|
| $R_{thJA}^{(1)}$ | Max. thermal resistance junction to ambient | 50         | $^{\circ}\text{C}/\text{W}$ |
| $T_{STG}$        | Storage temperature range                   | -40 to 150 | $^{\circ}\text{C}$          |
| $T_J$            | Junction operating temperature range        | -40 to 125 | $^{\circ}\text{C}$          |
| $T_A$            | Ambient operating temperature range         | -40 to +85 | $^{\circ}\text{C}$          |

1. Package mounted on demoboard

### 3 Pin connections and functions

Figure 2. Pins connection (top view)

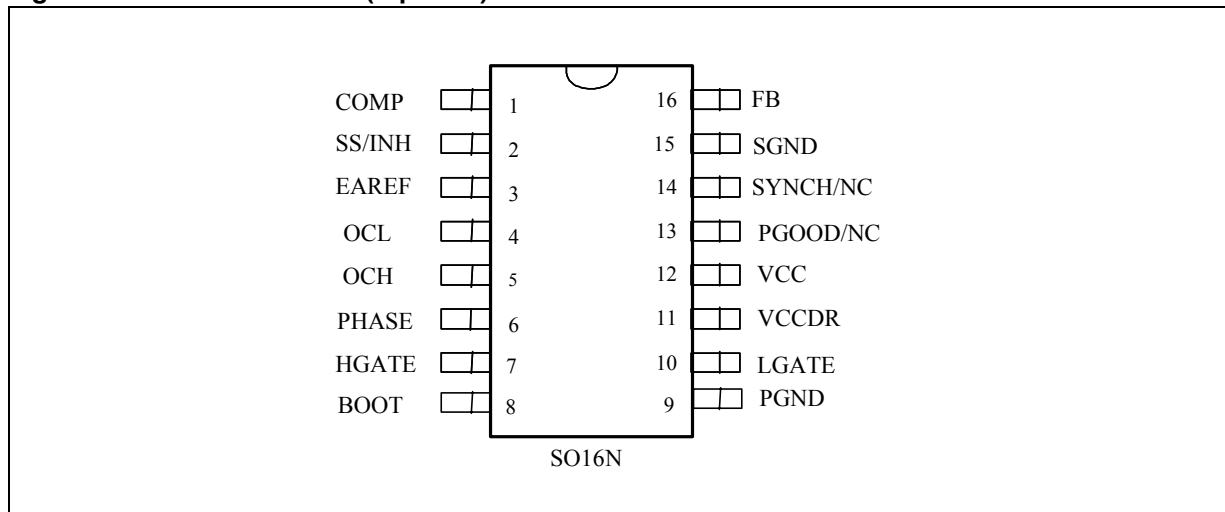

Table 4. Pin functions

| Pin n° | Name   | Function  |
|--------|--------|---|
| 1      | COMP   | This pin is connected to the error amplifier output and is used to compensate the voltage control feedback loop.  |
| 2      | SS/INH | The soft-start time is programmed connecting an external capacitor from this pin to GND. The internal current generator forces a current of 10µA through the capacitor. When the voltage at this pin is lower than 0.5V the device is disabled.   |
| 3      | EAREF  | By setting the voltage at this pin is possible to select the internal/external reference and the switching frequency:<br>$V_{EAREF} = 0-80\% \text{ of } V_{CCDR} \rightarrow \text{External Reference}/F_{SW} = 250\text{KHz}$<br>$V_{EAREF} = 80\% - 95\% \text{ of } V_{CCDR} \rightarrow V_{REF} = 0.6V/F_{SW} = 500\text{KHz}$<br>$V_{EAREF} = 95\% - 100\% \text{ of } V_{CCDR} \rightarrow V_{REF} = 0.6V/F_{SW} = 250\text{KHz}$<br>An internal clamp limits the maximum $V_{EAREF}$ at 2.5V (typ.). The device captures the analog value present at this pin at the start-up when $V_{CC}$ meets the UVLO threshold. |
| 4      | OCL    | A resistor connected from this pin to ground sets the valley- current-limit. The valley current is sensed through the low-side MOSFET(s). The internal current generator sources a current of 100µA ( $I_{OCL}$ ) from this pin to ground through the external resistor ( $R_{OCL}$ ). The over-current threshold is given by the following equation:<br>$I_{VALLEY} = \frac{I_{OCL} \cdot R_{OCL}}{2 \cdot R_{DSonLS}}$  |

Table 4. Pin functions

| Pin n° | Name                                 | Function   |
|--------|--------------------------------------|--|
| 5      | OCH                                  | <p>A resistor connected from this pin and the high-side MOSFET(s) drain sets the peak-current-limit. The peak current is sensed through the high-side MOSFET(s). The internal 100µA current generator (<math>I_{OCH}</math>) sinks a current from the drain through the external resistor (<math>R_{OCH}</math>). The over-current threshold is given by the following equation:</p> $I_{PEAK} = \frac{I_{OCH} \cdot R_{OCH}}{R_{DSonHS}}$ |
| 6      | PHASE                                | This pin is connected to the source of the high-side MOSFET(s) and provides the return path for the high-side driver. This pin monitors the drop across both the upper and lower MOSFET(s) for the current limit together with OCH and OCL.  |
| 7      | HGATE                                | This pin is connected to the high-side MOSFET(s) gate.   |
| 8      | BOOT                                 | Through this pin is supplied the high-side driver. Connect a capacitor from this pin to the PHASE pin and a diode from $V_{CCDR}$ to this pin (cathode versus BOOT).   |
| 9      | PGND                                 | This pin has to be connected closely to the low-side MOSFET(s) source in order to reduce the noise injection into the device.  |
| 10     | LGATE                                | This pin is connected to the low-side MOSFET(s) gate.  |
| 11     | $V_{CCDR}$                           | 5V internally regulated voltage. It is used to supply the internal drivers. Filter it to ground with a 1µF ceramic cap.  |
| 12     | $V_{CC}$                             | Supply voltage pin. The operative supply voltage range is from 4.5V to 14V.  |
| 13     | PGOOD<br>(L6725A)<br>N.C.<br>(L6725) | In L6725 this pin is N.C. With L6725A this pin is an open collector output and it is pulled low if the output voltage is not within the specified thresholds (90%-110%). If not used it may be left floating. Pull-up this pin to $V_{CCDR}$ with a 10K resistor to obtain a logical signal.   |
| 14     | SYNCH<br>(L6725A)<br>N.C.<br>(L6725) | In L6725 this pin is N.C. With L6725A it is a Master-Slave pin. Two or more devices can be synchronized by simply connecting the SYNCH pins together. The device operating with the highest FSW will be the Master. The Slave devices will operate with 180° phase shift from the Master. The best way to synchronize devices together is to set their FSW at the same value. If it is not used the SYNCH pin can be left floating.        |
| 15     | SGND                                 | All the internal references are referred to this pin.  |
| 16     | FB                                   | This pin is connected to the error amplifier inverting input. Connect it to $V_{OUT}$ through the compensation network. This pin is also used to sense the output voltage in order to manage the over voltage protection.  |

## 4 Electrical characteristics

$V_{CC} = 12V$ ,  $T_A = 25^\circ C$  unless otherwise specified.

**Table 5. Electrical characteristics**

| Symbol                               | Parameter                           | Test condition   | Min   | Typ  | Max   | Unit |
|--------------------------------------|-------------------------------------|--|-------|------|-------|------|
| <b>V<sub>CC</sub> supply current</b> |                                     |  |       |      |       |      |
| I <sub>CC</sub>                      | V <sub>CC</sub> Stand by current    | SS to GND  |       | 7    | 9     | mA   |
|                                      | V <sub>CC</sub> quiescent current   | HG = open, LG = open, PH=open                                  |       | 8.5  | 10    |      |
| <b>Power-ON</b>                      |                                     |  |       |      |       |      |
| V <sub>CC</sub>                      | Turn-ON V <sub>CC</sub> threshold   | V <sub>OCH</sub> = 1.7V  | 4.0   | 4.2  | 4.4   | V    |
|                                      | Turn-OFF V <sub>CC</sub> threshold  | V <sub>OCH</sub> = 1.7V  | 3.6   | 3.8  | 4.0   | V    |
| V <sub>IN OK</sub>                   | Turn-ON V <sub>OCH</sub> threshold  |  | 1.1   | 1.25 | 1.47  | V    |
|                                      | Turn-OFF V <sub>OCH</sub> threshold |  | 0.9   | 1.05 | 1.27  | V    |
| <b>V<sub>CCDR</sub> Regulation</b>   |                                     |  |       |      |       |      |
|                                      | V <sub>CCDR</sub> voltage           | V <sub>CC</sub> =5.5V to 18V<br>I <sub>DR</sub> = 1mA to 100mA | 4.5   | 5    | 5.5   | V    |
| <b>Soft Start and Inhibit</b>        |                                     |  |       |      |       |      |
| I <sub>SS</sub>                      | Soft Start Current                  | SS = 2V  | 7     | 10   | 13    | μA   |
|                                      |                                     | SS = 0 to 0.5V   | 20    | 30   | 45    |      |
| <b>Oscillator</b>                    |                                     |  |       |      |       |      |
| f <sub>OSC</sub>                     | Accuracy                            |  | 237   | 250  | 263   | KHz  |
|                                      |                                     |  | 450   | 500  | 550   | KHz  |
| ΔV <sub>OSC</sub>                    | Ramp Amplitude                      |  |       | 2.1  |       | V    |
| <b>Output Voltage</b>                |                                     |  |       |      |       |      |
| V <sub>FB</sub>                      | Output Voltage                      |  | 0.597 | 0.6  | 0.603 | V    |

Table 5. Electrical characteristics

| Symbol                 | Parameter                                     | Test condition                         | Min. | Typ.  | Max. | Unit       |
|------------------------|---|--|------|-------|------|------------|
| <b>Error Amplifier</b> |   |  |      |       |      |            |
| $R_{EAREF}$            | EAREF Input Resistance                        | Vs. GND                                | 70   | 100   | 150  | k $\Omega$ |
| $I_{FB}$               | I.I. bias current                             | $V_{FB} = 0V$                          |      | 0.290 | 0.5  | $\mu A$    |
| Ext Ref Clamp          |   |  | 2.3  |       |      | V          |
| $V_{OFFSET}$           | Error amplifier offset                        | $V_{ref} = 0.6V$                       | -5   |       | +5   | mV         |
| $G_V$                  | Open Loop Voltage Gain                        | Guaranteed by design                   |      | 100   |      | dB         |
| GBWP                   | Gain-Bandwidth Product                        | Guaranteed by design                   |      | 10    |      | MHz        |
| SR                     | Slew-Rate                                     | COMP = 10pF<br>Guaranteed by design    |      | 5     |      | V/ $\mu s$ |
| <b>Gate drivers</b>    |   |  |      |       |      |            |
| $R_{HGATE\_ON}$        | High Side Source Resistance                   | $V_{BOOT} - V_{PHASE} = 5V$            |      | 1.7   |      | $\Omega$   |
| $R_{HGATE\_OFF}$       | High Side Sink Resistance                     | $V_{BOOT} - V_{PHASE} = 5V$            |      | 1.12  |      | $\Omega$   |
| $R_{LGATE\_ON}$        | Low Side Source Resistance                    | $V_{CCDR} = 5V$                        |      | 1.15  |      | $\Omega$   |
| $R_{LGATE\_OFF}$       | Low Side Sink Resistance                      | $V_{CCDR} = 5V$                        |      | 0.6   |      | $\Omega$   |
| <b>Protections</b>     |   |  |      |       |      |            |
| $I_{OCH}$              | OCH Current Source                            | $V_{OCH} = 1.7V$                       | 90   | 100   | 110  | $\mu A$    |
| $I_{OCL}$              | OCL Current Source                            |  | 90   | 100   | 110  | $\mu A$    |
| OVP                    | Over Voltage Trip<br>( $V_{FB} / V_{EAREF}$ ) | $V_{FB}$ Rising<br>$V_{EAREF} = 0.6V$  |      | 120   |      | %          |
|                        |   | $V_{FB}$ Falling<br>$V_{EAREF} = 0.6V$ |      | 117   |      | %          |

## 5 Device description

The controller provides complete control logic and protection for flexible and cost-effective DC-DC converters. It is designed to drive N-Channel MOSFETs in a synchronous rectified buck topology. The output voltage of the converter can be precisely regulated down to 600mV with a maximum tolerance of  $\pm 0.8\%$ , when the internal reference is used. The device allows also using an external reference (0V to 2.5V) for the regulation. The device provides voltage-mode control. The switching frequency can be set at two different values: 250KHz or 500KHz. The error amplifier features a 10MHz gain-bandwidth-product and 5V/ $\mu$ s slew-rate that permits to realize high converter bandwidth for fast transient response. The PWM duty cycle can range from 0% to 100%. The device protects against over current conditions providing a constant-current-protection during the soft-start phase and entering in HICCUP mode in all the other conditions. The device monitors the current by using the  $R_{DS(ON)}$  of both the high-side and low-side MOSFET(s), eliminating the need for a current sensing resistor and guaranteeing an effective over-current-protection in all the application conditions. Other features are over-voltage-protection and thermal shutdown. The device is available in SO16N package.

### 5.1 Oscillator

The switching frequency can be fixed to two values: 250KHz or 500KHz by setting the proper voltage at the EAREF pin (see [Table 4](#). Pins function and section 4.3 Internal and external reference).

### 5.2 Internal LDO

An internal LDO supplies the internal circuitry of the device. The input of this stage is the  $V_{CC}$  pin and the output (5V) is the  $V_{CCDR}$  pin. The LDO can be by-passed, providing directly a 5V voltage to  $V_{CCDR}$ . In this case  $V_{CC}$  and  $V_{CCDR}$  pins must be shorted together as shown in [Figure 3](#).  $V_{CCDR}$  pin must be filtered with a 1uF capacitor to sustain the internal LDO during the recharge of the bootstrap capacitor.

### 5.3 Bypassing the LDO to avoid the voltage drop with low Vcc

If  $V_{CC} \approx 5V$  the internal LDO works in dropout with an output resistance of about  $1\Omega$ . The maximum LDO output current is about 100mA and so the output voltage drop is 100mV, to avoid this the LDO can be bypassed.

Figure 3. Bypassing the LDO

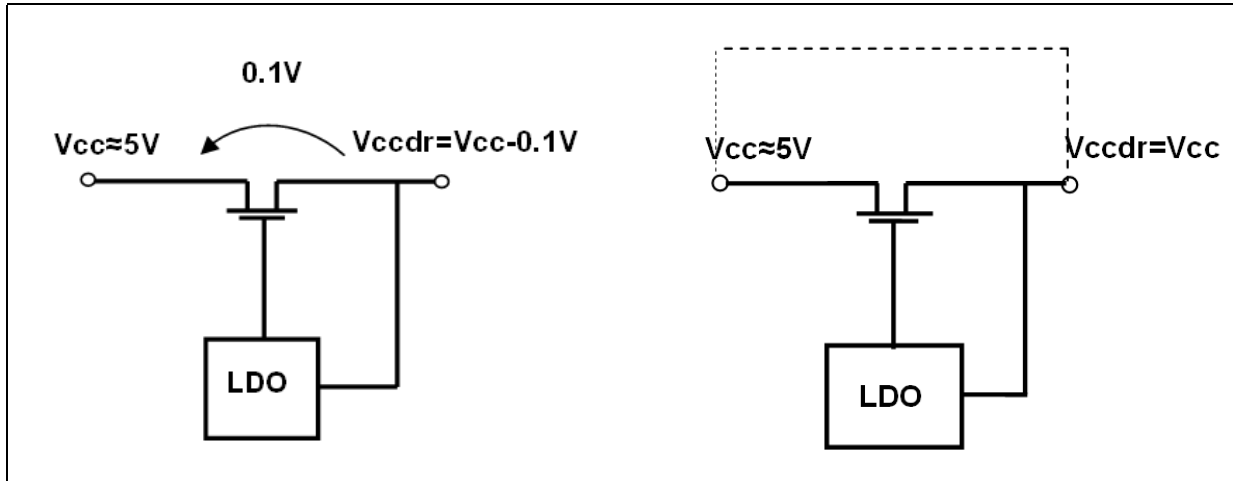

### 5.4 Internal and external references

It is possible to set the internal/external reference and the switching frequency by setting the proper voltage at the EAREF pin. The maximum value of the external reference depends on the  $V_{CC}$ : with  $V_{CC} = 4V$  the clamp operates at about 2V (typ.), while with  $V_{CC}$  greater than 5V the maximum external reference is 2.5V (typ.).

- $V_{EAREF}$  from 0% to 80% of  $V_{CCDR}$  -> External reference/Fsw = 250KHz
- $V_{EAREF}$  from 80% to 95% of  $V_{CCDR}$  ->  $V_{REF} = 0.6V/Fsw = 500KHz$
- $V_{EAREF}$  from 95% to 100% of  $V_{CCDR}$  ->  $V_{REF} = 0.6V/Fsw = 250KHz$

Providing an external reference from 0V to 450mV the output voltage will be regulated but some restrictions must be considered:

- The minimum OVP threshold is set at 300mV;
- The under-voltage-protection doesn't work;

To set the resistor divider it must be considered that a 100K pull-down resistor is integrated into the device (see [Figure 4.](#)). Finally it must be taken into account that the voltage at the EAREF pin is captured by the device at the start-up when  $V_{CC}$  is about 4V.

### 5.5 Error amplifier

Figure 4. Error amplifier reference

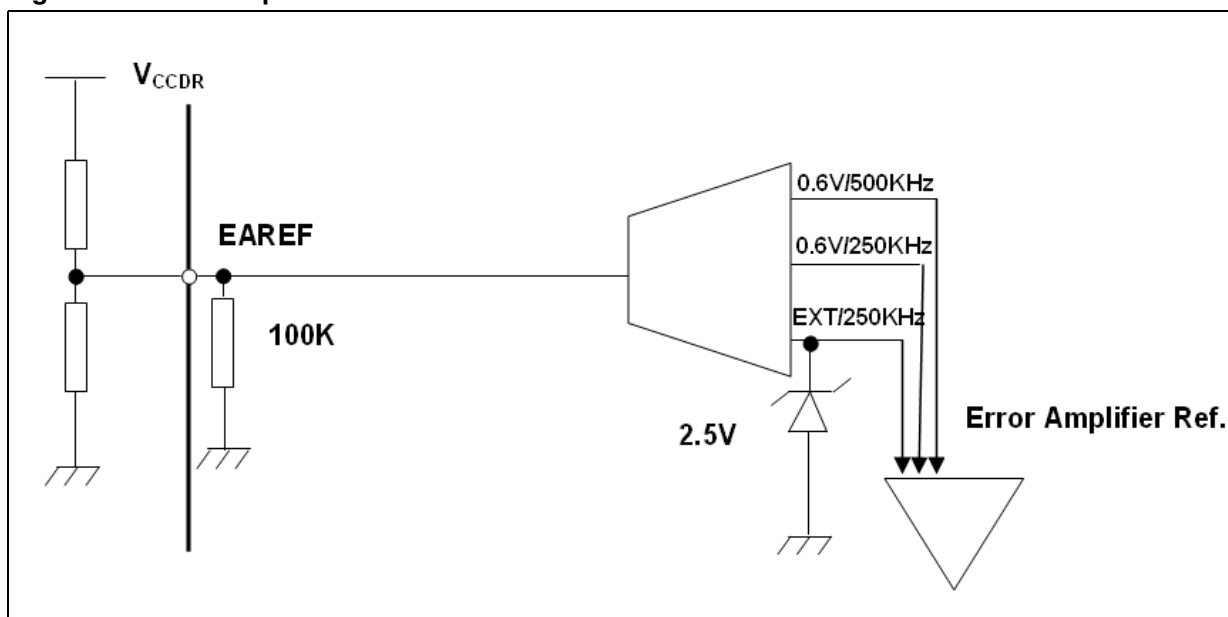

### 5.6 Soft start

When both  $V_{CC}$  and  $V_{IN}$  are above their turn-ON thresholds ( $V_{IN}$  is monitored by the OCH pin) the start-up phase takes place. Otherwise the SS pin is internally shorted to GND. At start-up, a ramp is generated charging the external capacitor  $C_{SS}$  with an internal current generator. The initial value for this current is  $35\mu A$  and charges the capacitor up to  $0.5V$ . After that it becomes  $10\mu A$  until the final charge value of approximately  $4V$  (see [Figure 5](#)).

Figure 5. Soft-Start phase.

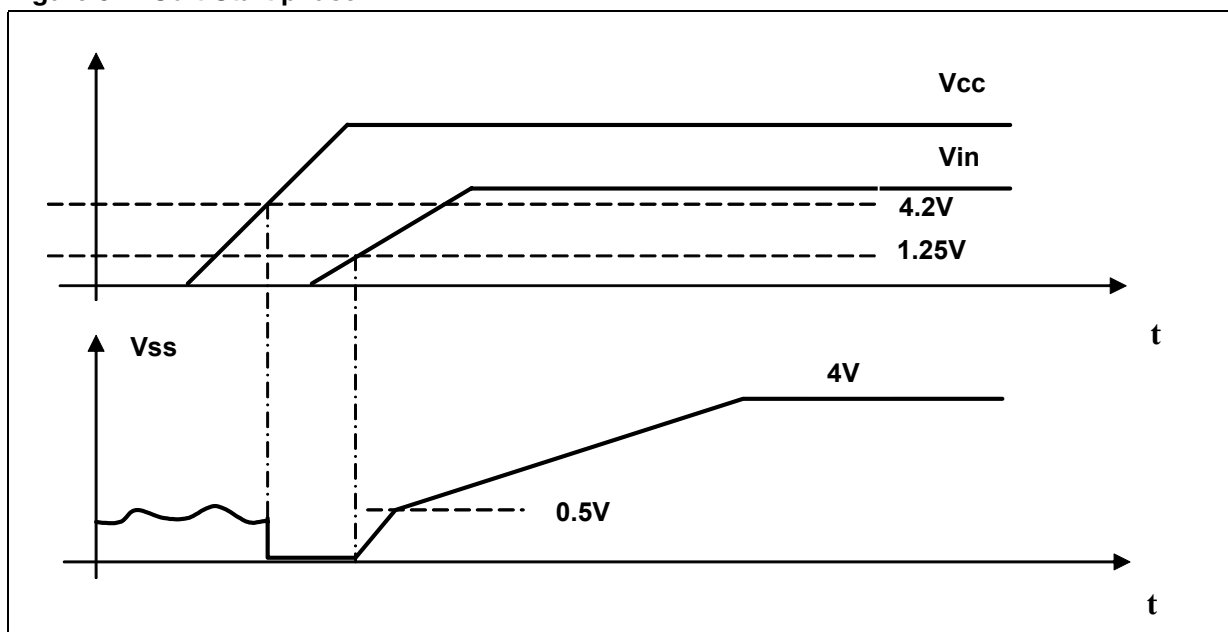

L6725: The output of the error amplifier is clamped with this voltage ( $V_{SS}$ ) until it reaches the programmed value.

L6725A: The reference of the error amplifier is clamped with this voltage ( $V_{SS}$ ) until it reaches the programmed value. No switching activity is observable if  $V_{SS}$  is lower than 0.5V and both MOSFETs are OFF. When  $V_{SS}$  is between 0.5V and 1.1V the low-side MOSFET is turned ON. As  $V_{SS}$  reaches 1.1V (i.e. the oscillator triangular wave inferior limit) even the high-side MOSFET begins to switch and the output voltage starts to increase. During the soft-start phase the current can't be reversed in order to allow pre-biased start-up (see [Figure 6](#). and [Figure 7](#)).

Figure 6. Start-up without pre-bias

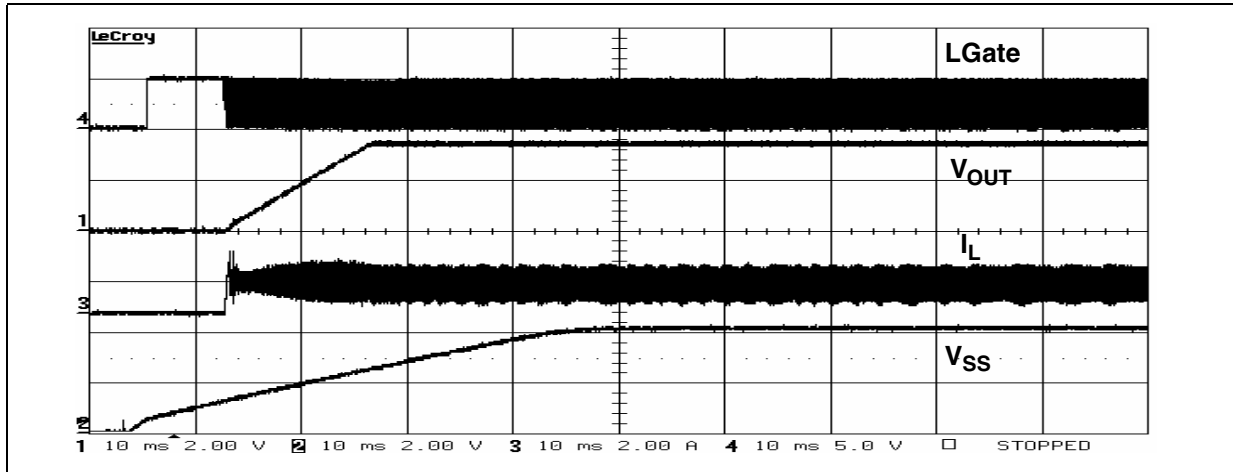
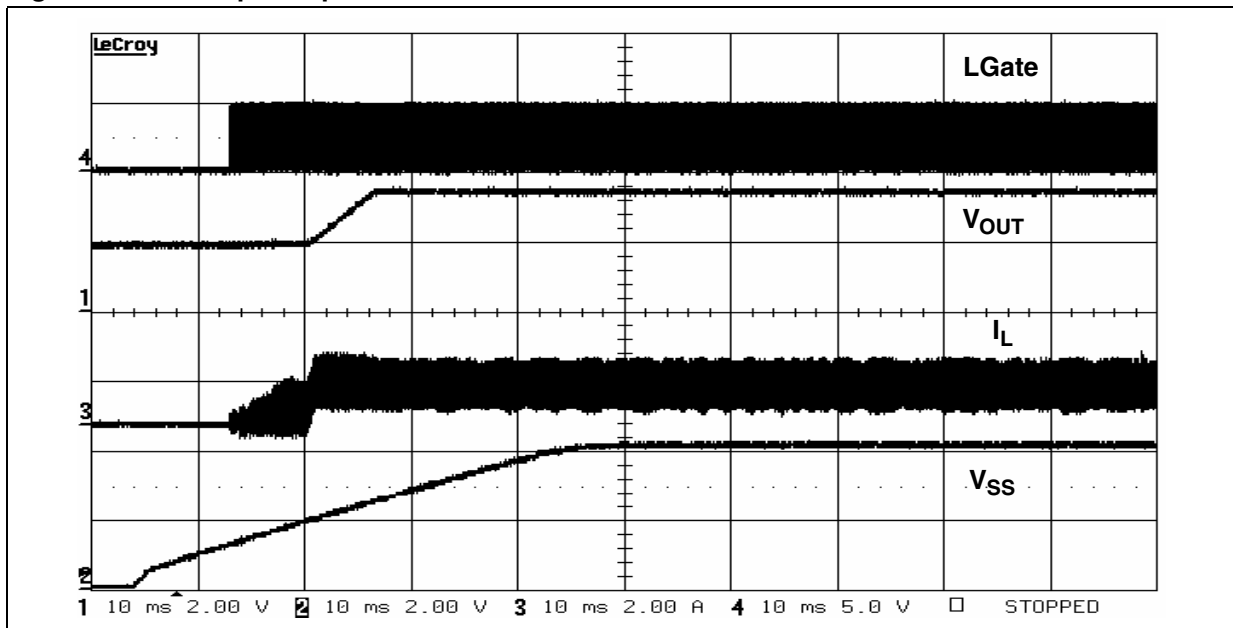

Figure 7. Start-up with pre-bias



If an over current is detected during the soft-start phase, the device provides a constant-current-protection. In this way, in case of short soft-start time and/or small inductor value and/or high output capacitors value, the converter can start in any case, limiting the current ([Chapter 5.8: Monitoring and protections on page 14](#)). The soft-start phase ends when  $V_{SS}$  reaches 3.5V. After that the over-current-protection triggers the HICCUP mode.

## 5.7 Driver section

The high-side and low-side drivers allow using different types of power MOSFETs (also multiple MOSFETs to reduce the  $R_{DS(ON)}$ ), maintaining fast switching transitions. The low-side driver is supplied by  $V_{CCDR}$  while the high-side driver is supplied by the BOOT pin. A predictive dead time control avoids MOSFETs cross-conduction maintaining very short dead time duration in the range of 20ns. The control monitors the phase node in order to sense the low-side body diode recirculation. If the phase node voltage is less than a certain threshold (-350mV typ.) during the dead time, it will be reduced in the next PWM cycle. The predictive dead time control doesn't work when the high-side body diode is conducting because the phase node doesn't go negative. This situation happens when the converter is sinking current for example and, in this case, an adaptive dead time control operates.

## 5.8 Monitoring and protections

The output voltage is monitored by means of pin FB. The device provides over-voltage-protection: when the voltage sensed on FB pin reaches a value 20% (typ.) greater than the reference the low-side driver is turned on as long as the over voltage is detected (see [Figure 8](#)).

Figure 8. OVP

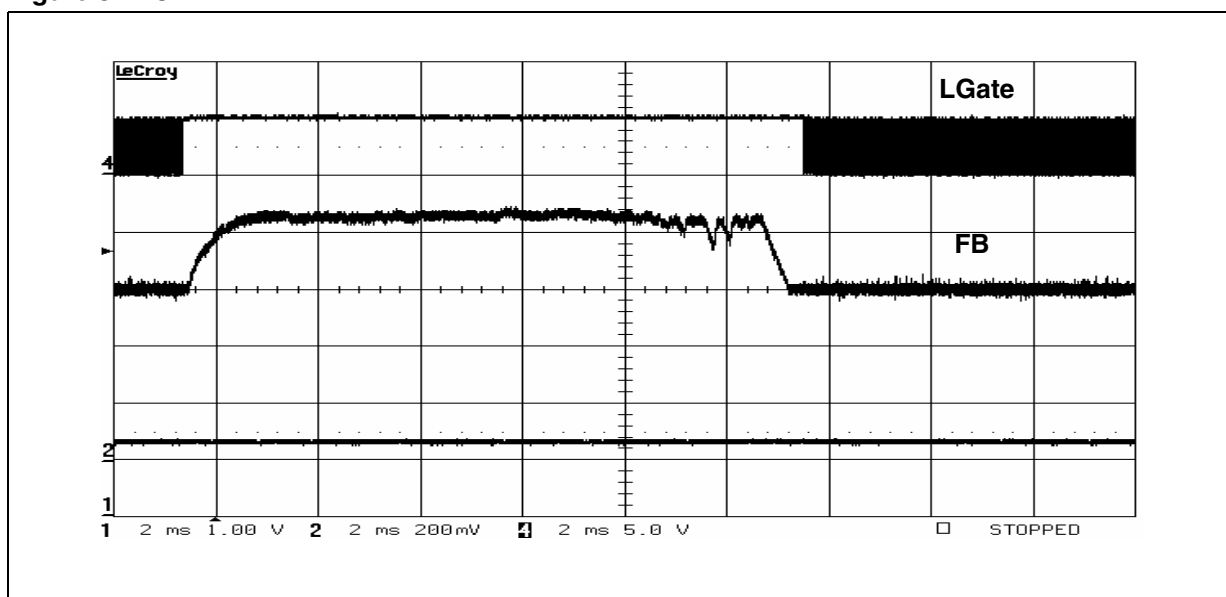

The device realizes the over-current-protection (OCP) sensing the current both on the high-side MOSFET(s) and the low-side MOSFET(s) and so 2 current limit thresholds can be set (see OCH pin and OCL pin in [Table 4: Pin functions](#)):

- Peak Current Limit
- Valley Current Limit

The Peak Current Protection is active when the high-side MOSFET(s) is turned on, after a masking time of 100ns. The valley-current-protection is enabled when the low-side MOSFET(s) is turned on after a masking time of 500ns. If, when the soft-start phase is completed, an over current event occurs during the on time (peak-current-protection) or during the off time (valley-current-protection) the device enters in HICCUP mode: the high-side and low-side MOSFET(s) are turned off, the soft-start capacitor is discharged with a constant current of 10 $\mu$ A and when the voltage at the SS pin reaches 0.5V the soft-start phase restarts (see [Figure 9](#)).

## 5.9 Hiccup mode

Figure 9. Constant current and Hiccup Mode during an OCP.

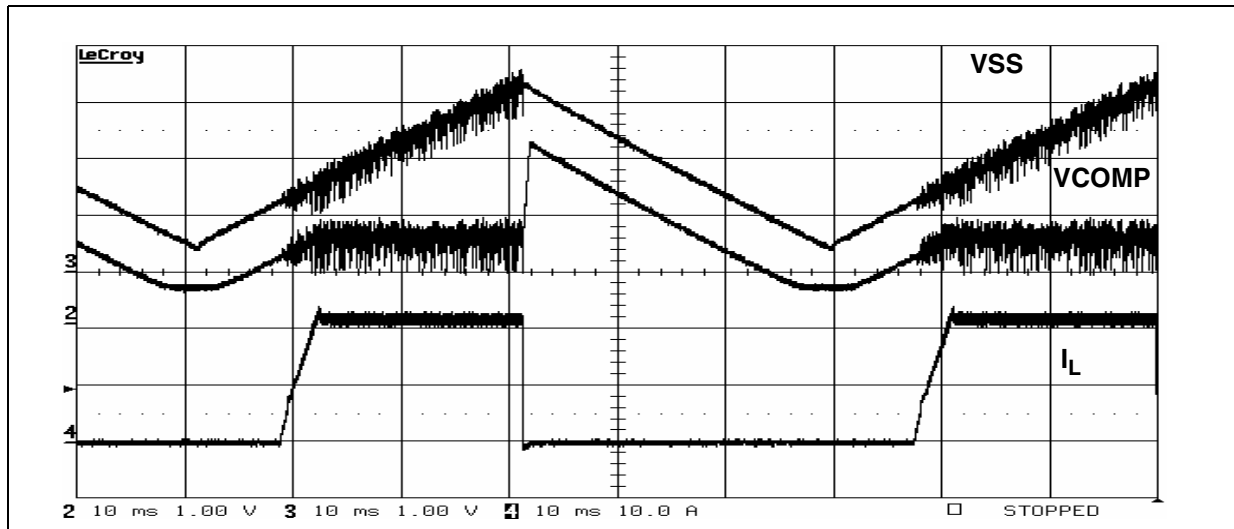

During the soft-start phase the OCP provides a constant-current-protection. If during the  $T_{ON}$  the OCH comparator triggers an over current the high-side MOSFET(s) is immediately turned OFF (after the masking time and the internal delay) and returned on at the next pwm cycle. The limit of this protection is that the  $T_{ON}$  cannot be less than masking time plus propagation delay, because during the masking time the peak-current-protection is disabled. In case of very hard short circuit, even with this short  $T_{ON}$ , the current could escalate. The valley-current-protection is very helpful in this case to limit the current. If during the off-time the OCL comparator triggers an over current, the high-side MOSFET(s) is not turned on until the current is over the valley-current-limit. This implies that, if it is necessary, some pulses of the high-side MOSFET(s) will be skipped, guaranteeing a maximum current due to the following formula:

$$I_{MAX} = I_{VALLEY} + \frac{V_{in} - V_{out}}{L} \cdot T_{ON,MIN} \quad (1)$$

## 5.10 Thermal shutdown

When the junction temperature reaches  $150^{\circ}\text{C} \pm 10^{\circ}\text{C}$  the device enters in thermal shutdown. Both MOSFETs are turned OFF and the soft-start capacitor is rapidly discharged with an internal switch. The device does not restart until the junction temperature goes down to  $120^{\circ}\text{C}$  and, in any case, until the voltage at the soft-start pin reaches 500mV.

## 5.11 Synchronization

The presence of many converters on the same board can generate beating frequency noise. To avoid this it is important to make them operate at the same switching frequency. Moreover, a phase shift between different modules helps to minimize the RMS current on the common input capacitors. [Figure 10.](#) and [Figure 11.](#) shows the results of two modules in synchronization. Two or more devices can be synchronized simply connecting together the SYNCH pins. The device with the higher switching frequency will be the Master while the other one will be the Slave. The Slave controller will increase its switching frequency reducing the ramp amplitude proportionally and then the modulator gain will be increased.

**Figure 10. Synchronization: PWM Signal**

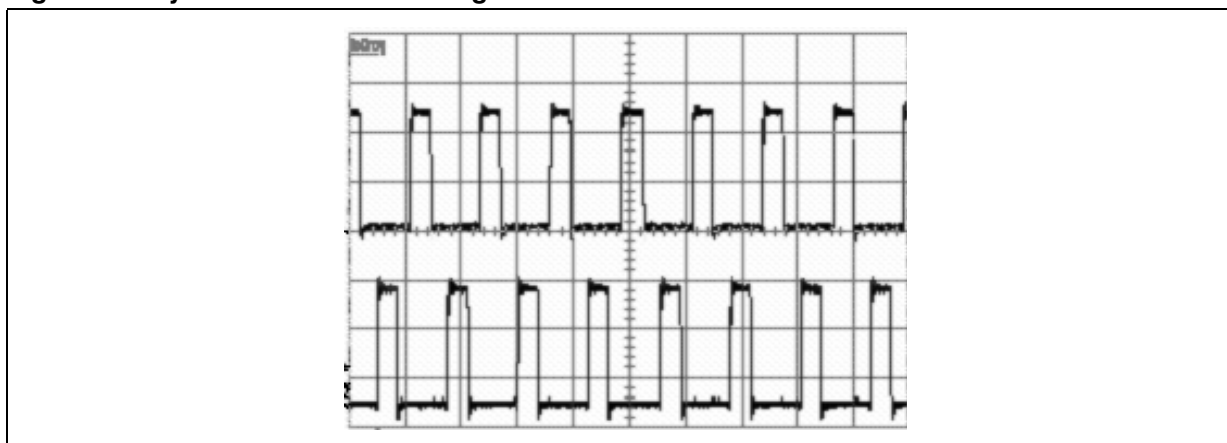

**Figure 11. Synchronization: Inductor Currents**

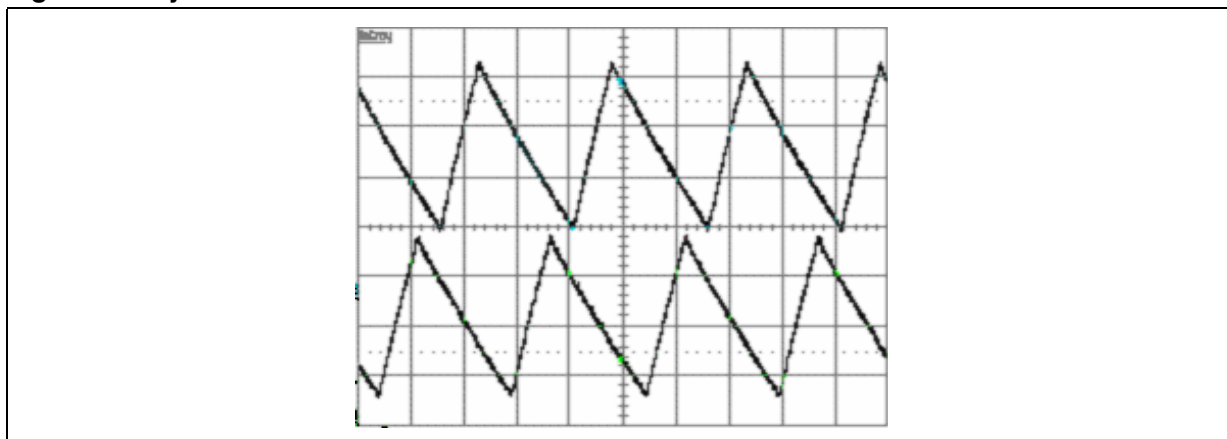

To avoid a huge variation of the modulator gain, the best way to synchronize two or more devices is to make them work at the same switching frequency and, in any case, the switching frequencies can differ for a maximum of 50% of the lowest one. If, during synchronization between two (or more) L6725A, it's important to know in advance which the master is, it's timely to set its switching frequency at least 15% higher than the slave. Using an external clock signal ( $f_{EXT}$ ) to synchronize one or more devices that are working at a different switching frequency ( $f_{SW}$ ) it is recommended to follow the below formula:

$$f_{SW} \leq f_{EXT} \leq 1,3 \cdot f_{SW}$$

The phase shift between master and slaves is approximately 180°.

## 5.12 Bootstrap anti-discharging system

This built-in system avoids that the voltage across the bootstrap capacitor becomes less than 3.3V. An internal comparator senses the voltage across the external bootstrap capacitor keeping it charged, eventually turning-on the low-side MOSFET for approximately 200ns. If the bootstrap capacitor is not enough charged the high-side MOSFET cannot be effectively turned-on and it will present a higher  $R_{DS(ON)}$ . In some cases the OCP can be also triggered. The bootstrap capacitor can be discharged during the soft-start in case of very long soft-start time and light loads. It's also possible to mention one application condition during which the bootstrap capacitor can be discharged:

### 5.12.1 Fan's power supply

In many applications the FAN is a DC MOTOR driven by a voltage-mode DC/DC converter. Often only the speed of the MOTOR is controlled by varying the voltage applied to the input terminal and there's no control on the torque because the current is not directly controlled. In order to vary the MOTOR speed the output voltage of the converter must be varied. The L6725 has a dedicated pin called EAREF (see the related section) that allows providing an external reference to the non-inverting input of the error-amplifier.

In these applications the duty cycle depends on the MOTOR's speed and sometimes 100% has to be set in order to go at the maximum speed. Unfortunately in these conditions the bootstrap capacitor can not be recharged and the system cannot work properly. Some PWM controller limits the maximum duty-cycle to 80-90% in order to keep the bootstrap cap charged but this make worse the performance during the load transient. Thanks to the "bootstrap anti-discharging system" the L6732 can work at 100% without any problem. The following picture shows the device behaviour when input voltage is 5V and 100% is set by the external reference.

Figure 12. 100% duty cycle operation

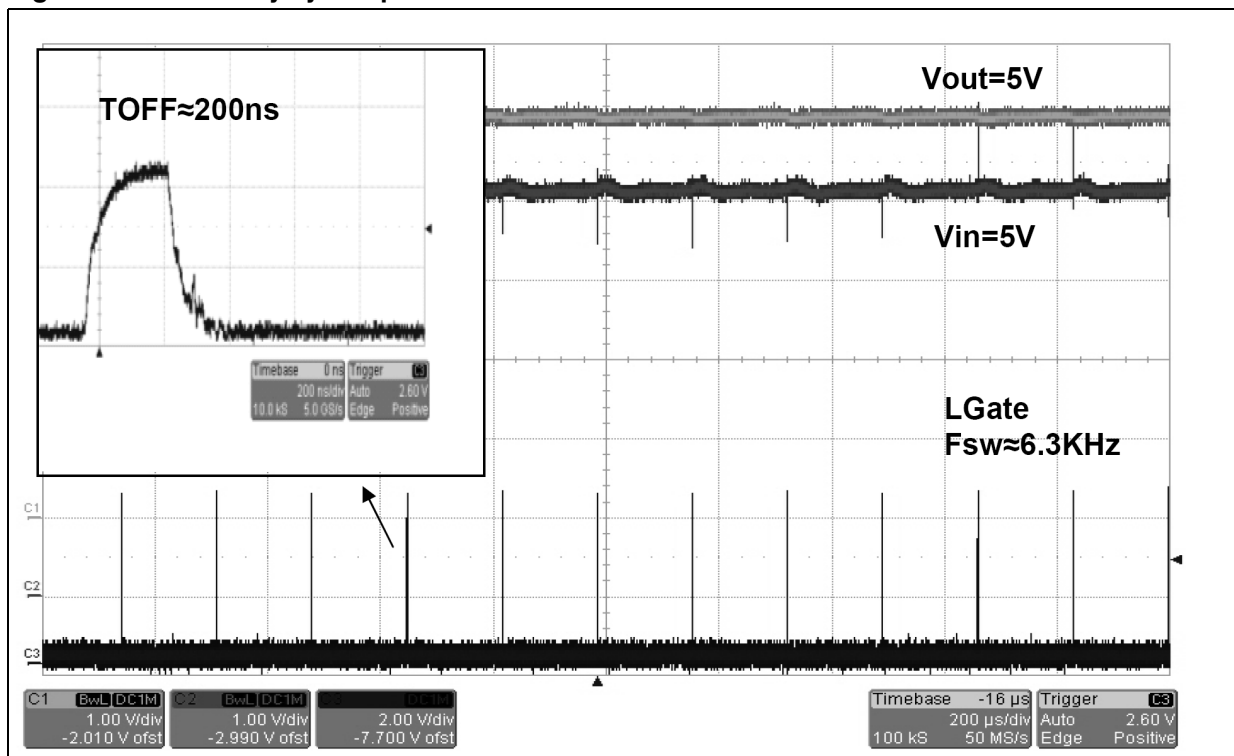

## 6 Application details

### 6.1 Inductor design

The inductance value is defined by a compromise between the transient response time, the efficiency, the cost and the size. The inductor has to be calculated to sustain the output and the input voltage variation to maintain the ripple current ( $\Delta I_L$ ) between 20% and 30% of the maximum output current. The inductance value can be calculated with the following relationship:

$$L \cong \frac{V_{in} - V_{out}}{F_{sw} \cdot \Delta I_L} \cdot \frac{V_{out}}{V_{in}} \quad (2)$$

Where  $F_{SW}$  is the switching frequency,  $V_{IN}$  is the input voltage and  $V_{OUT}$  is the output voltage. [Figure 13](#) shows the ripple current vs. the output voltage for different values of the inductor, with  $V_{IN} = 5V$  and  $V_{IN} = 12V$  at a switching frequency of 500KHz.

**Figure 13. Inductor current ripple.**

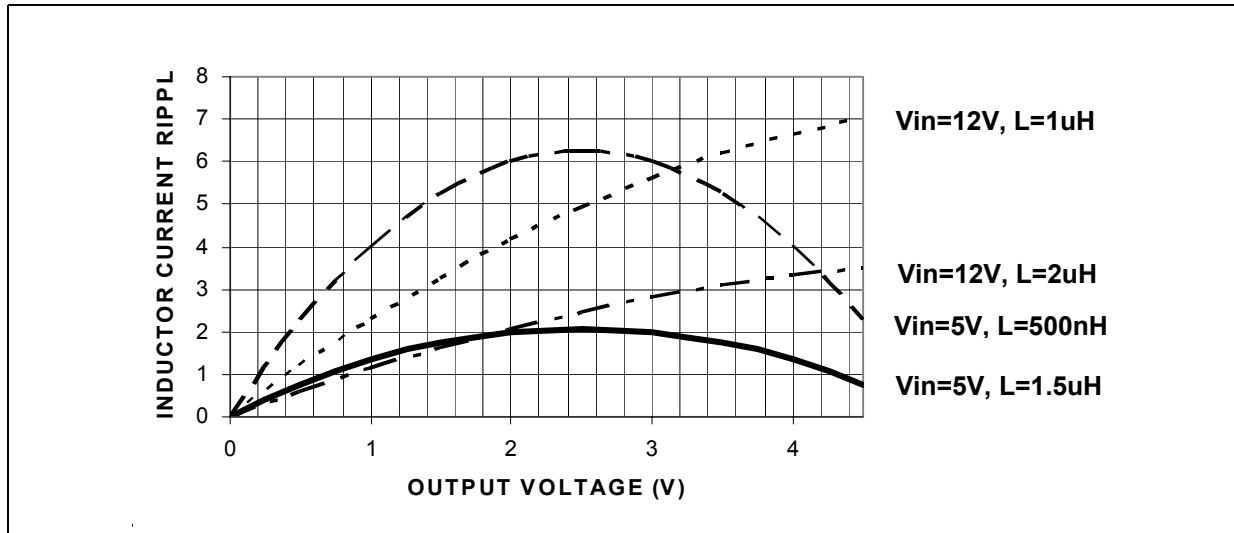

Increasing the value of the inductance reduces the ripple current but, at the same time, increases the converter response time to a load transient. If the compensation network is well designed, during a load transient the device is able to set the duty cycle to 100% or to 0%. When one of these conditions is reached, the response time is limited by the time required to change the inductor current. During this time the output current is supplied by the output capacitors. Minimizing the response time can minimize the output capacitor size.

## 6.2 Output capacitors

The output capacitors are basic components for the fast transient response of the power supply. For example, during a positive load transient, they supply the current to the load until the converter reacts. The controller recognizes immediately the load transient and sets the duty cycle at 100%, but the current slope is limited by the inductor value. The output voltage has a first drop due to the current variation inside the capacitor (neglecting the effect of the ESL):

$$\Delta V_{out_{ESR}} = \Delta I_{out} \cdot ESR \quad (3)$$

Moreover, there is an additional drop due to the effective capacitor discharge that is given by:

$$\Delta V_{out_{COUT}} = \frac{\Delta I_{out}^2 \cdot L}{2 \cdot C_{out} \cdot (V_{in, \min} \cdot D_{\max} - V_{out})} \quad (4)$$

Where  $D_{MAX}$  is the maximum duty cycle value that in the L6725 is 100%. Usually the voltage drop due to the ESR is the biggest one while the drop due to the capacitor discharge is almost negligible. Moreover the ESR value also affects the voltage static ripple, that is:

$$\Delta V_{out} = ESR \cdot \Delta I_L \quad (5)$$

## 6.3 Input capacitors

The input capacitors have to sustain the RMS current flowing through them, that is:

$$I_{rms} = I_{out} \cdot \sqrt{D \cdot (1 - D)} \quad (6)$$

Where D is the duty cycle. The equation reaches its maximum value,  $I_{OUT} / 2$  with  $D = 0.5$ . The losses in worst case are:

$$P = ESR \cdot (0.5 \cdot I_{out})^2 \quad (7)$$

## 6.4 Compensation network

The loop is based on a voltage mode control (*Figure 14*). The output voltage is regulated to the internal/external reference voltage and scaled by the external resistor divider. The error amplifier output  $V_{COMP}$  is then compared with the oscillator triangular waveform to provide a pulse-width modulated (PWM) with an amplitude of  $V_{IN}$  at the PHASE node. This waveform is filtered by the output filter. The modulator transfer function is the small signal transfer function of  $V_{OUT}/V_{COMP}$ . This function has a double pole at frequency  $F_{LC}$  depending on the  $L-C_{OUT}$  resonance and a zero at  $F_{ESR}$  depending on the output capacitor's ESR. The DC Gain of the modulator is simply the input voltage  $V_{IN}$  divided by the peak-to-peak oscillator voltage:  $V_{OSC}$ .

**Figure 14. Compensation Network**

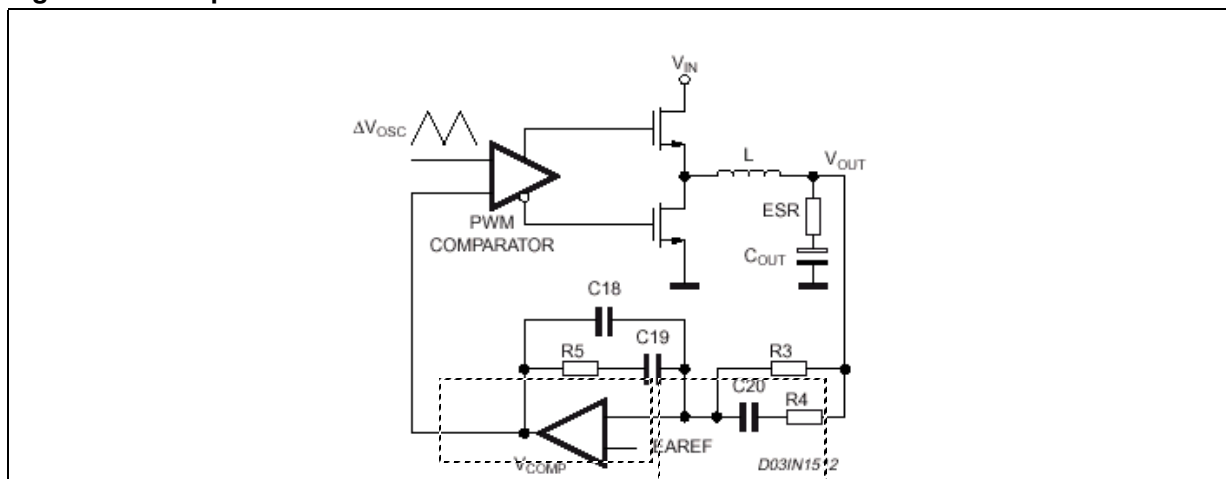

The compensation network consists in the internal error amplifier, the impedance networks  $Z_{IN}$  (R3, R4 and C20) and  $Z_{FB}$  (R5, C18 and C19). The compensation network has to provide a closed loop transfer function with the highest 0dB crossing frequency to have fastest transient response (but always lower than  $f_{SW}/10$ ) and the highest gain in DC conditions to minimize the load regulation error. A stable control loop has a gain crossing the 0dB axis with -20dB/decade slope and a phase margin greater than 45°. To locate poles and zeroes of the compensation networks, the following suggestions may be used:

- Modulator singularity frequencies:

$$\omega_{LC} = \frac{1}{\sqrt{L \cdot C_{out}}} \quad (8)$$

$$\omega_{ESR} = \frac{1}{ESR \cdot C_{out}} \quad (9)$$

- Compensation network singularity frequencies:

$$\omega_{P1} = \frac{1}{R_5 \cdot \left( \frac{C_{18} \cdot C_{19}}{C_{18} + C_{19}} \right)} \quad (10)$$

$$\omega_{P2} = \frac{1}{R_4 \cdot C_{20}} \quad (11)$$

$$\omega_{Z1} = \frac{1}{R_5 \cdot C_{19}} \quad (12)$$

$$\omega_{Z2} = \frac{1}{C_{20} \cdot (R_3 + R_4)} \quad (13)$$

- Compensation network design:

- Put the gain  $R_5/R_3$  in order to obtain the desired converter bandwidth:

$$\omega_c = \frac{R_5}{R_3} \cdot \frac{V_{in}}{\Delta V_{osc}} \cdot \omega_{LC} \quad (14)$$

- Place  $\omega_{Z1}$  before the output filter resonance  $\omega_{LC}$ ;
- Place  $\omega_{Z2}$  at the output filter resonance  $\omega_{LC}$ ;
- Place  $\omega_{P1}$  at the output capacitor ESR zero  $\omega_{ESR}$ ;
- Place  $\omega_{P2}$  at one half of the switching frequency;
- Check the loop gain considering the error amplifier open loop gain.

Figure 15. Asymptotic Bode plot of Converter's open loop gain

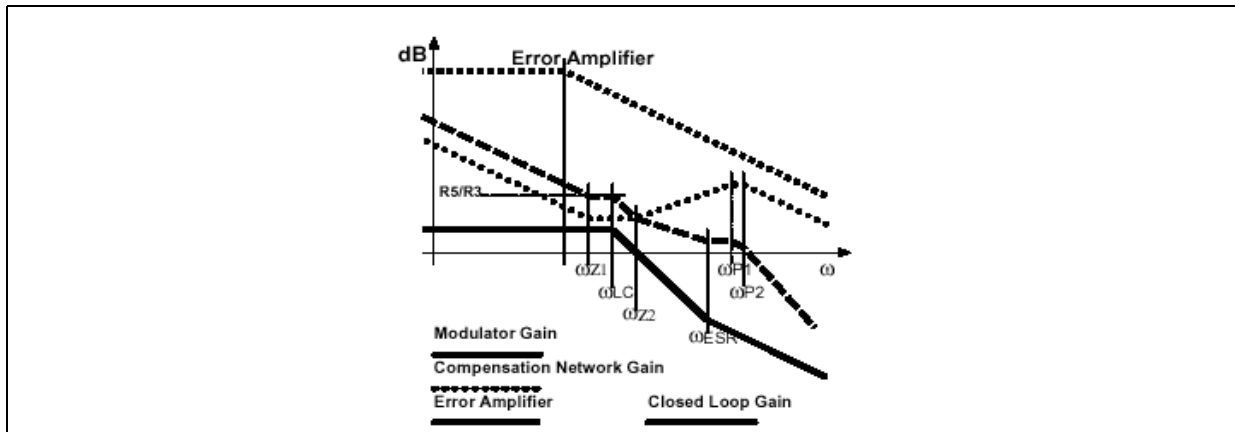

# 7 Demoboard

## 7.1 20A board description

L6725 demoboard realizes in a four layer PCB a step-down DC/DC converter and shows the operation of the device in a general purpose application. The input voltage can range from 4.5V to 14V and the output voltage is at 3.3V. The module can deliver an output current in excess of 20A. The switching frequency is set at 250kHz (controller free-running FBSWB) but it can be set to 500kHz acting on the EAREF pin.

Figure 16. Demoboard schematic

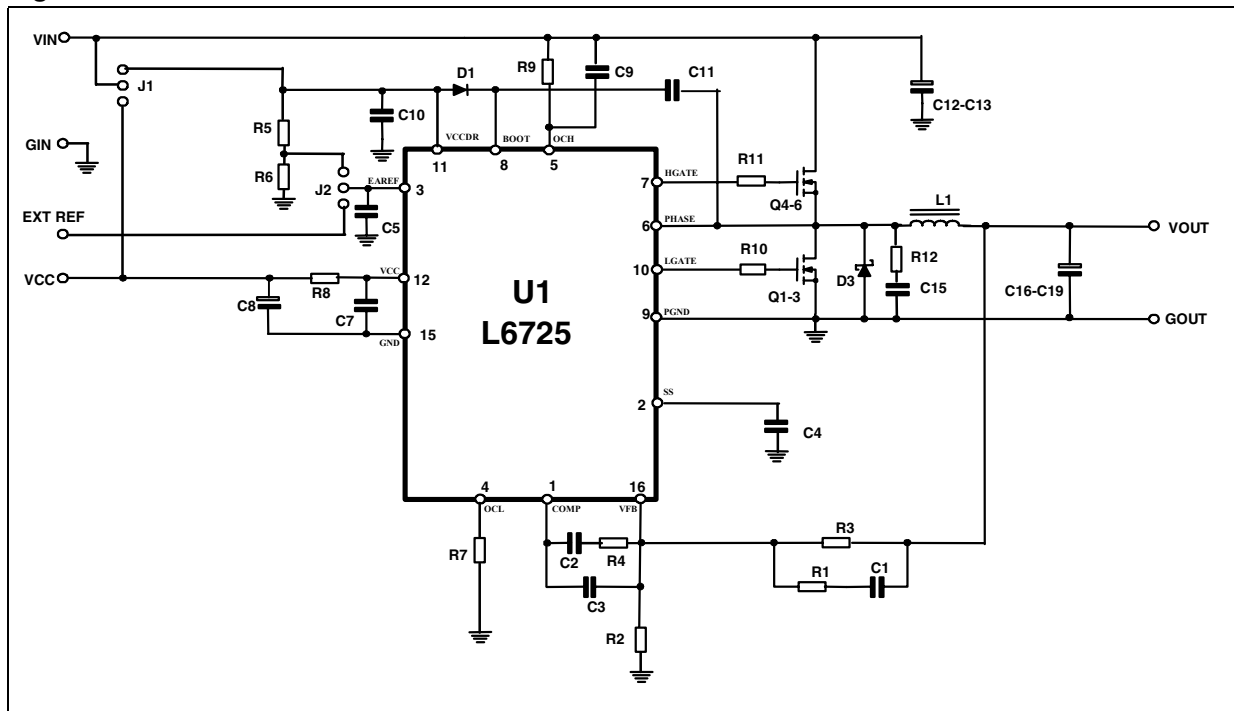

Table 6. Demoboard part list

| Reference | Value           | Manufacturer | Package  | Supplier    |
|-----------|-----------------|--------------|----------|-------------|
| R1        | 1k $\Omega$     | Neohm        | SMD 0603 | IFARCAD     |
| R2        | 1k $\Omega$     | Neohm        | SMD 0603 | IFARCAD     |
| R3        | 4K7             |              |          |             |
| R4        | 2k7             | Neohm        | SMD 0603 | IFARCAD     |
| R5        | 0 $\Omega$      | Neohm        | SMD 0603 | IFARCAD     |
| R6        | N.C.            | Neohm        | SMD 0603 | IFARCAD     |
| R7        | 2K $\Omega$     | Neohm        | SMD 0603 | IFARCAD     |
| R8        | 10 $\Omega$     | Neohm        | SMD 0603 | IFARCAD     |
| R9        | 1K $\Omega$     | Neohm        | SMD 0603 | IFARCAD     |
| R10       | 2.2 $\Omega$    | Neohm        | SMD 0603 | IFARCAD     |
| R11       | 2.2 $\Omega$    | Neohm        | SMD 0603 | IFARCAD     |
| R12       | N.C.            | Neohm        | SMD 0603 | IFARCAD     |
| C1        | 4.7nF           | Kemet        | SMD 0603 | IFARCAD     |
| C2        | 47nF            | Kemet        | SMD 0603 | IFARCAD     |
| C3        | 1nF             | Kemet        | SMD 0603 | IFARCAD     |
| C4        | 100nF           | Kemet        | SMD 0603 | IFARCAD     |
| C5        | 100nF           | Kemet        | SMD 0603 | IFARCAD     |
| C6        | N.C.            | /            | /        | /           |
| C7        | 100nF           | Kemet        | SMD 0603 | IFARCAD     |
| C8        | 4.7 $\mu$ F 20V | AVX          | SMA6032  | IFARCAD     |
| C9        | 1nF             | Kemet        | SMD 0603 | IFARCAD     |
| C10       | 1 $\mu$ F       | Kemet        | SMD 0603 | IFARCAD     |
| C11       | 220nF           | Kemet        | SMD 0603 | IFARCAD     |
| C12-13    | 3X 15 $\mu$ F   | /            | /        | ST (TDK)    |
| C15       | N.C.            | /            | /        | /           |
| C16-19    | 2X 330 $\mu$ F  | /            | /        | ST (poscap) |
| L1        | 1.8 $\mu$ H     | Panasonic    | SMD      | ST          |
| D1        | STPS1L30M       | ST           | DO216AA  | ST          |
| D3        | N.C.            | /            | /        | /           |
| Q1-Q2     | STS12NH3LL      | ST           | SO8      | ST          |
| Q4-Q5     | STS25NH3LL      | ST           | SO8      | ST          |
| U1        | L6725           | ST           | SO16N    | ST          |

**Table 7. Other inductor manufacturer**

| Manufacturer     | Series            | Inductor Value ( $\mu\text{H}$ ) | Saturation Current (A) |
|------------------|-------------------|----------------------------------|------------------------|
| WURTH ELEKTRONIC | 744318180         | 1.8                              | 20                     |
| SUMIDA           | CDEP134-2R7MC-H   | 2.7                              | 15                     |
| EPCOS            | HPI_13 T640       | 1.4                              | 22                     |
| TDK              | SPM12550T-1R0M220 | 1                                | 22                     |
| TOKO             | FDA1254           | 2.2                              | 14                     |
| COILTRONICS      | HCF1305-1R0       | 1.15                             | 22                     |
|                  | HC5-1R0           | 1.3                              | 27                     |

**Table 8. Other capacitor manufacturer**

| Manufacturer     | Series         | Capacitor value( $\mu\text{F}$ ) | Rated voltage (V) |
|------------------|----------------|----------------------------------|-------------------|
| TDK              | C4532X5R1E156M | 15                               | 25                |
|                  | C3225X5R0J107M | 100                              | 6.3               |
| NIPPON CHEMI-CON | 25PS100MJ12    | 100                              | 25                |
| PANASONIC        | ECJ4YB0J107M   | 100                              | 6.3               |

**Figure 17. Demoboard efficiency**

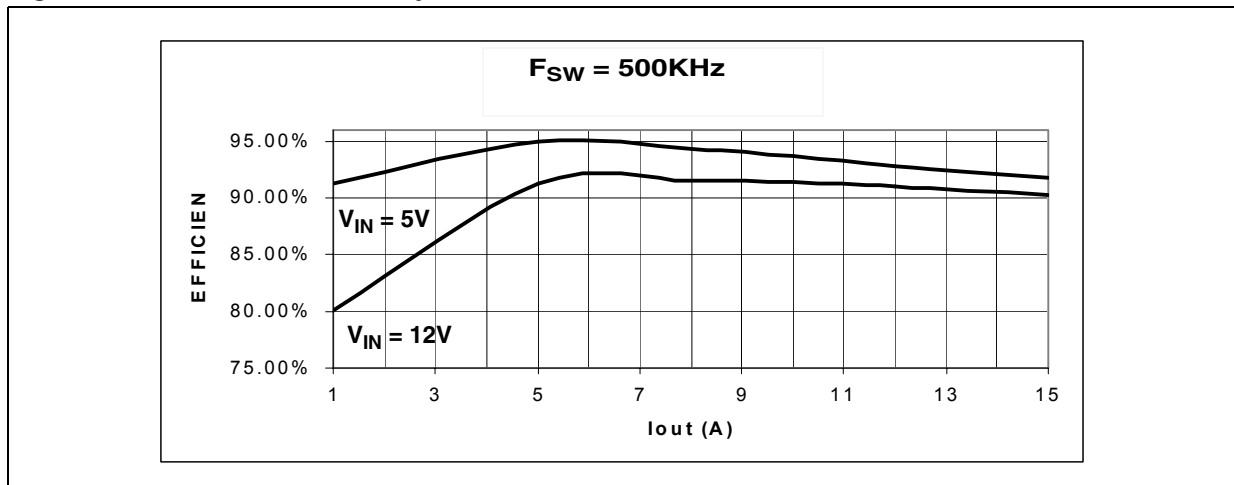

Figure 18. PCB Layout: top layer

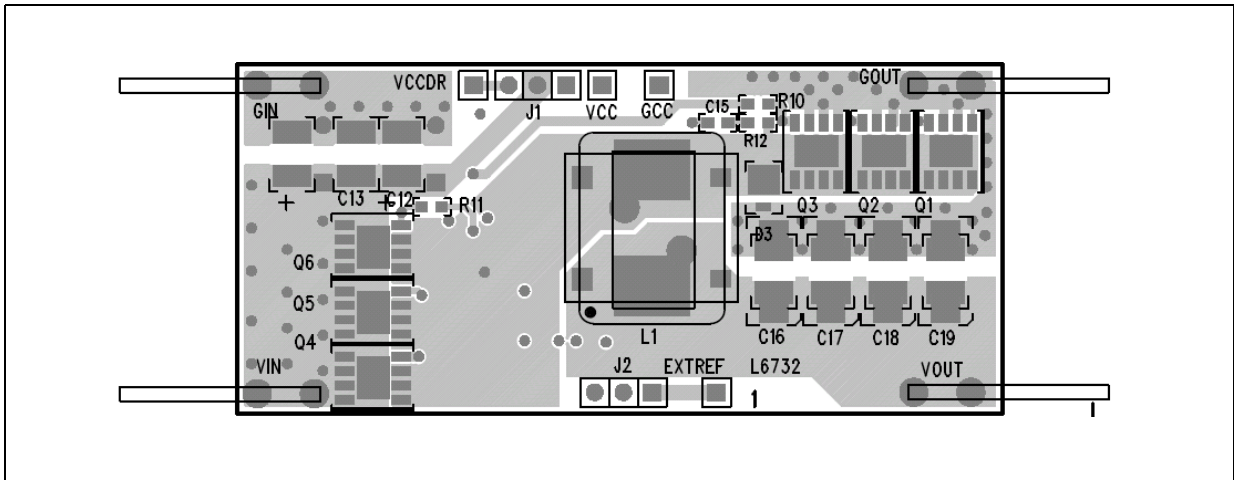

Figure 19. PCB Layout: power ground layer

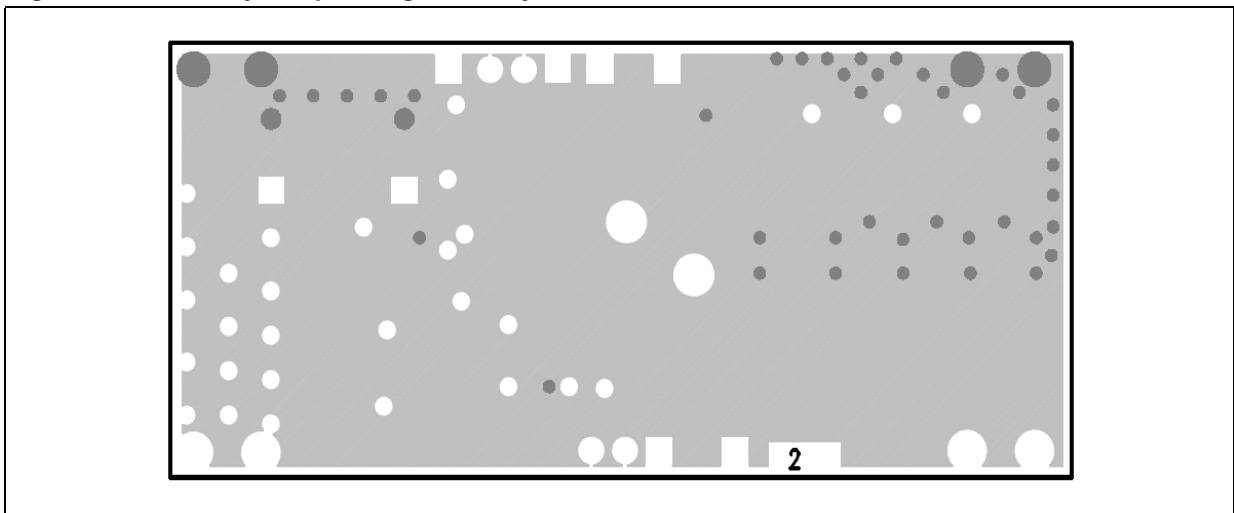

Figure 20. PCB Layout: signal-ground layer

