



Chipsmall Limited consists of a professional team with an average of over 10 year of expertise in the distribution of electronic components. Based in Hongkong, we have already established firm and mutual-benefit business relationships with customers from,Europe,America and south Asia,supplying obsolete and hard-to-find components to meet their specific needs.

With the principle of “Quality Parts,Customers Priority,Honest Operation,and Considerate Service”,our business mainly focus on the distribution of electronic components. Line cards we deal with include Microchip,ALPS,ROHM,Xilinx,Pulse,ON,Everlight and Freescale. Main products comprise IC,Modules,Potentiometer,IC Socket,Relay,Connector.Our parts cover such applications as commercial,industrial, and automotives areas.

We are looking forward to setting up business relationship with you and hope to provide you with the best service and solution. Let us make a better world for our industry!



Contact us

Tel: +86-755-8981 8866 Fax: +86-755-8427 6832

Email & Skype: info@chipsmall.com Web: www.chipsmall.com

Address: A1208, Overseas Decoration Building, #122 Zhenhua RD., Futian, Shenzhen, China



3 A step-down switching regulator

Datasheet - production data

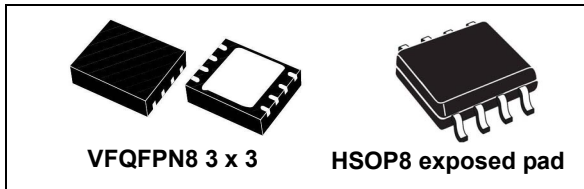

- Industrial:
 - PLD, PLA, FPGA, chargers
- Networking: XDSL, modems, DC-DC modules
- Computer:
 - Optical storage, hard disk drive, printers, audio/graphic cards
- Suitable for LED driving

Features

- 3 A DC output current
- 4.5 V to 28 V input voltage
- Output voltage adjustable from 0.6 V
- 250 kHz switching frequency, programmable up to 1 MHz
- Internal soft-start and enable
- Low dropout operation: 100% duty cycle
- Voltage feed-forward
- Zero load current operation
- Overcurrent and thermal protection
- VFQFPN 3 x 3 - 8L and HSOP8 package

Description

The L7981 device is a step-down switching regulator with a 3.7 A (minimum) current limited embedded Power MOSFET, so it is able to deliver up to 3 A current to the load depending on the application conditions.

The input voltage can range from 4.5 V to 28 V, while the output voltage can be set starting from 0.6 V to V_{IN} .

Requiring a minimum set of external components, the device includes an internal 250 kHz switching frequency oscillator that can be externally adjusted up to 1 MHz.

The QFN and the HSOP packages with exposed pad allow reducing the R_{thJA} down to 60°C/W and 40°C/W respectively.

Applications

- Consumer:
 - STB, DVD, DVD recorder, car audio, LCD TV and monitors

Figure 1. Application circuit

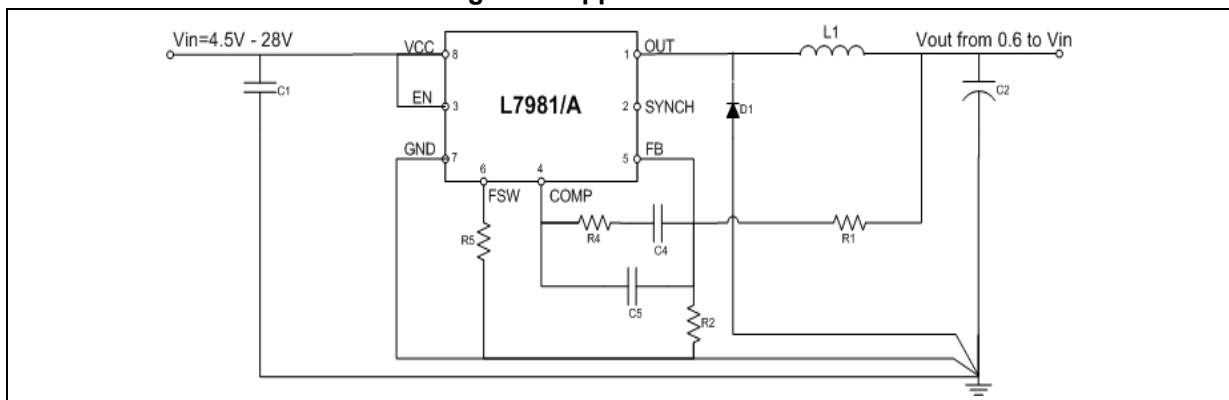

Contents

1	Pin settings	4
1.1	Pin connection	4
1.2	Pin description	4
2	Maximum ratings	5
3	Thermal data	5
4	Electrical characteristics	6
5	Functional description	8
5.1	Oscillator and synchronization	9
5.2	Soft-start	11
5.3	Error amplifier and compensation	12
5.4	Overcurrent protection	13
5.5	Enable function	14
5.6	Hysteretic thermal shutdown	14
6	Application informations	15
6.1	Input capacitor selection	15
6.2	Inductor selection	16
6.3	Output capacitor selection	17
6.4	Compensation network	18
6.4.1	Type III compensation network	20
6.4.2	Type II compensation network	24
6.5	Thermal considerations	27
6.6	Layout considerations	28
6.7	Application circuit	30
7	Application ideas	34
7.1	Positive buck-boost	34
7.2	Inverting buck-boost	36

8	Package information	38
9	Order codes	41
10	Revision history	41

1 Pin settings

1.1 Pin connection

Figure 2. Pin connection (top view)

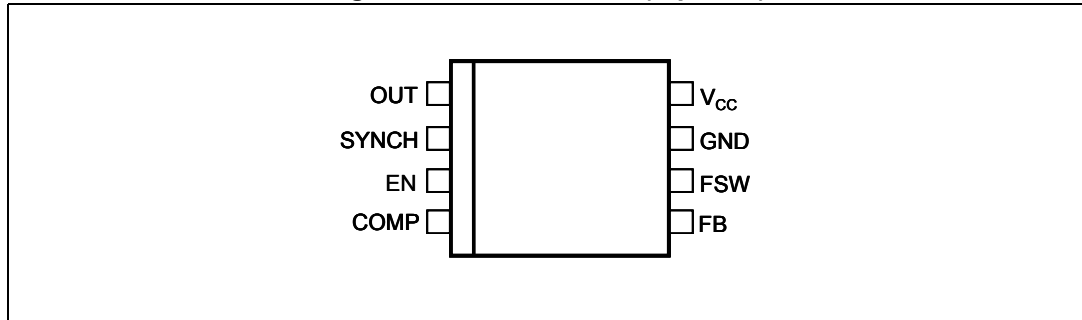

1.2 Pin description

Table 1. Pin description

No.	Type	Description
1	OUT	Regulator output
2	SYNCH	Master/slave synchronization. When it is left floating, a signal with a phase shift of half a period respect to the power turn on is present at the pin. When connected to an external signal at a frequency higher than the internal one, then the device is synchronized by the external signal, with zero phase shift. Connecting together the SYNCH pin of two devices, the one with higher frequency works as master and the other one as slave; so the two powers turn on have a phase shift of half a period.
3	EN	A logical signal (active high) enable the device. With EN higher than 1.2 V the device is ON and with EN is lower than 0.3 V the device is OFF.
4	COMP	Error amplifier output to be used for loop frequency compensation
5	FB	Feedback input. Connecting the output voltage directly to this pin the output voltage is regulated at 0.6 V. To have higher regulated voltages an external resistor divider is required from Vout to the FB pin.
6	F _{SW}	The switching frequency can be increased connecting an external resistor from the FSW pin and ground. If this pin is left floating the device works at its free-running frequency of 250 kHz.
7	GND	Ground
8	V _{CC}	Unregulated DC input voltage

2 Maximum ratings

Table 2. Absolute maximum ratings

Symbol	Parameter		Value	Unit
V _{CC}	Input voltage		30	V
OUT	Output DC voltage		-0.3 to V _{CC}	
F _{SW} , COMP, SYNCH	Analog pin		-0.3 to 4	
EN	Enable pin		-0.3 to V _{CC}	
FB	Feedback voltage		-0.3 to 1.5	
P _{TOT}	Power dissipation at T _A < 60 °C	VFQFPN	1.5.	W
		HSOP	2	
T _J	Junction temperature range		-40 to 150	°C
T _{stg}	Storage temperature range		-55 to 150	°C

3 Thermal data

Table 3. Thermal data

Symbol	Parameter		Value	Unit
R _{thJA}	Maximum thermal resistance junction ambient ⁽¹⁾	VFQFPN	60	°C/W
		HSOP	40	

1. Package mounted on demonstration board.

4 Electrical characteristics

$T_J = 25\text{ }^\circ\text{C}$, $V_{CC} = 12\text{ V}$, unless otherwise specified.

Table 4. Electrical characteristics

Symbol	Parameter	Test condition	Values			Unit
			Min.	Typ.	Max.	
V_{CC}	Operating input voltage range	(1)	4.5		28	V
V_{CCON}	Turn on V_{CC} threshold	(1)			4.4	
V_{CCHYS}	V_{CC} UVLO hysteresis	(1)	0.12		0.35	
R_{DSON}	Mosfet on resistance			160	180	m Ω
		(1)		160	250	
I_{LIM}	Maximum limiting current		3.7	4.2	4.7	A
Oscillator						
F_{SW}	Switching frequency		225	250	275	KHz
		(1)	220		275	
V_{FSW}	FSW pin voltage			1.254		V
D	Duty cycle		0		100	%
F_{ADJ}	Adjustable switching frequency	$R_{FSW} = 33\text{ k}\Omega$		1000		KHz
Dynamic characteristics						
V_{FB}	Feedback voltage	$4.5\text{ V} < V_{CC} < 28\text{ V}^{(1)}$	0.593	0.6	0.607	V
DC characteristics						
I_Q	Quiescent current	Duty cycle = 0, $V_{FB} = 0.8\text{ V}$			2.4	mA
I_{QST-BY}	Total standby quiescent current			20	30	μA
Enable						
	EN threshold voltage	Device OFF level			0.3	V
		Device ON level	1.2			
	EN current	$EN = V_{CC}$		7.5	10	μA
Soft-start						
T_{SS}	Soft-start duration	FSW pin floating	7.4	8.2	9.1	ms
		$F_{SW} = 1\text{ MHz}$, $R_{FSW} = 33\text{ k}\Omega$		2		
Error amplifier						
V_{CH}	High level output voltage	$V_{FB} < 0.6\text{ V}$	3			V
V_{CL}	Low level output voltage	$V_{FB} > 0.6\text{ V}$			0.1	
$I_{O\text{ SOURCE}}$	Source COMP pin	$V_{FB} = 0.5\text{ V}$, $V_{COMP} = 1\text{ V}$		17		mA

Table 4. Electrical characteristics (continued)

Symbol	Parameter	Test condition	Values			Unit
			Min.	Typ.	Max.	
$I_{O\ SINK}$	Sink COMP pin	$V_{FB} = 0.7\ V, V_{COMP} = 1\ V$		25		mA
G_V	Open loop voltage gain	(2)		100		dB
Synchronization function						
	High input voltage		2		3.3	V
	Low input voltage				1	
	Slave sink current	$V_{SYNCH} = 2.9\ V$		0.7	0.9	mA
	Master output amplitude	$I_{SOURCE} = 4.5\ mA$	2.0			V
	Output pulse width	SYNCH floating		110		ns
	Input pulse width		70			
Protection						
T_{SHDN}	Thermal shutdown			150		°C
	Hysteresis			30		

1. Specification referred to T_J from -40 to +125 °C. Specification in the -40 to +125 °C temperature range are assured by design, characterization and statistical correlation.
2. Guaranteed by design.

5 Functional description

The L7981 device is based on a “voltage mode”, constant frequency control. The output voltage V_{OUT} is sensed by the feedback pin (FB) compared to an internal reference (0.6 V) providing an error signal that, compared to a fixed frequency sawtooth, controls the on and off time of the power switch.

The main internal blocks are shown in the block diagram in *Figure 3*. They are:

- A fully integrated oscillator that provides sawtooth to modulate the duty cycle and the synchronization signal. Its switching frequency can be adjusted by an external resistor. The voltage and frequency feed forward are implemented.
- The soft-start circuitry to limit inrush current during the start-up phase.
- The voltage mode error amplifier
- The pulse width modulator and the relative logic circuitry necessary to drive the internal power switch.
- The high-side driver for embedded P-channel Power MOSFET switch.
- The peak current limit sensing block, to handle overload and short-circuit conditions.
- A voltage regulator and internal reference. It supplies internal circuitry and provides a fixed internal reference.
- A voltage monitor circuitry (UVLO) that checks the input and internal voltages.
- A thermal shutdown block, to prevent thermal runaway.

Figure 3. Block diagram

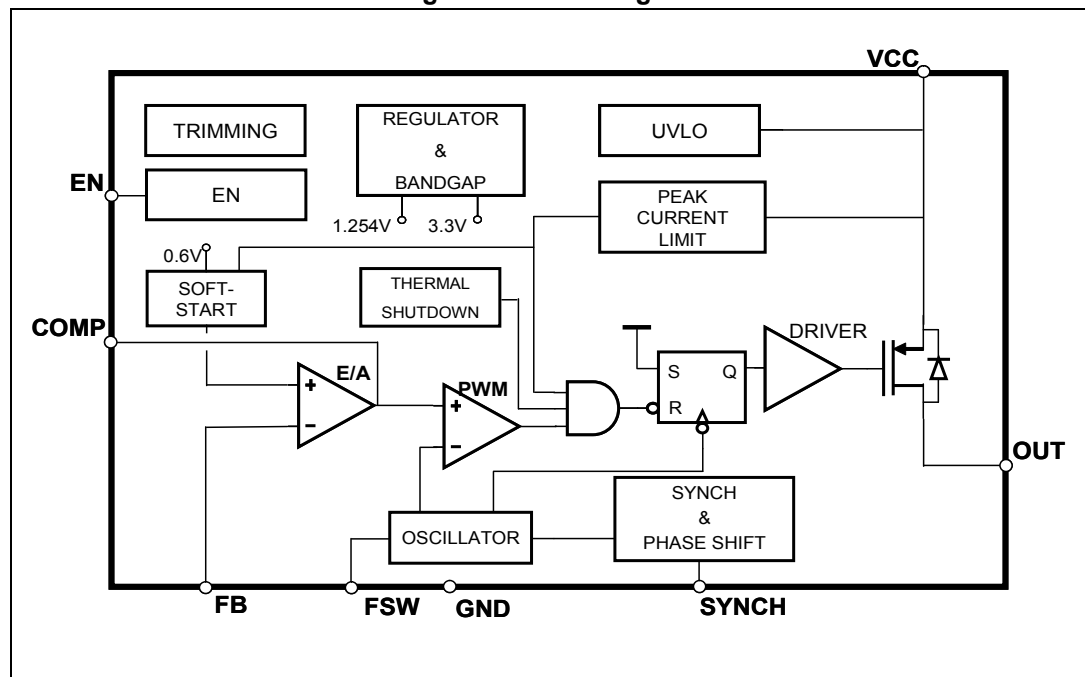

5.1 Oscillator and synchronization

Figure 4 shows the block diagram of the oscillator circuit. The internal oscillator provides a constant frequency clock. Its frequency depends on the resistor externally connected to the FSW pin. In case the FSW pin is left floating the frequency is 250 kHz; it can be increased as shown in *Figure 6* by external resistor connected to ground.

To improve the line transient performance, keeping the PWM gain constant versus the input voltage, the voltage feed forward is implemented by changing the slope of the sawtooth according to the input voltage change (see *Figure 5.a*).

The slope of the sawtooth also changes if the oscillator frequency is increased by the external resistor. In this way a frequency feed forward is implemented (*Figure 5.b*) in order to keep the PWM gain constant versus the switching frequency (see *Section 6.4 on page 18* for PWM gain expression).

On the SYNCH pin the synchronization signal is generated. This signal has a phase shift of 180° with respect to the clock. This delay is useful when two devices are synchronized connecting the SYNCH pin together. When SYNCH pins are connected, the device with higher oscillator frequency works as the master, so the slave device switches at the frequency of the master but with a delay of half a period. This minimizes the RMS current flowing through the input capacitor (see the L5988D datasheet).

Figure 4. Oscillator circuit block diagram

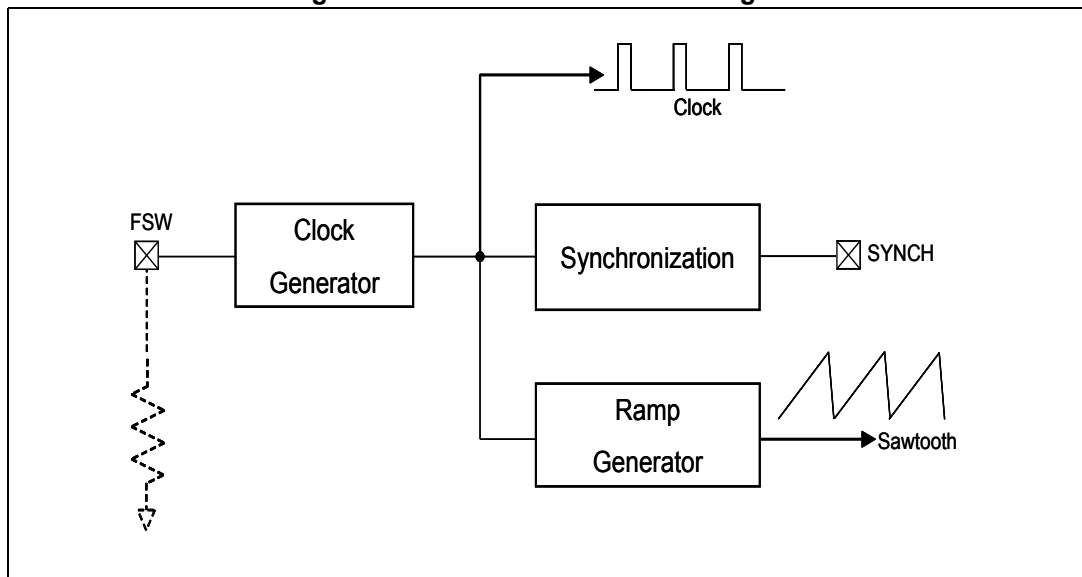

The device can be synchronized to work at higher frequency feeding an external clock signal. The synchronization changes the sawtooth amplitude, changing the PWM gain (*Figure 5.c*). This changing has to be taken into account when the loop stability is studied. To minimize the change of the PWM gain, the free running frequency should be set (with a resistor on the FSW pin) only slightly lower than the external clock frequency. This pre-adjusting of the frequency will change the sawtooth slope in order to get negligible the truncation of sawtooth, due to the external synchronization.

Figure 5. Sawtooth: voltage and frequency feed forward; external synchronization

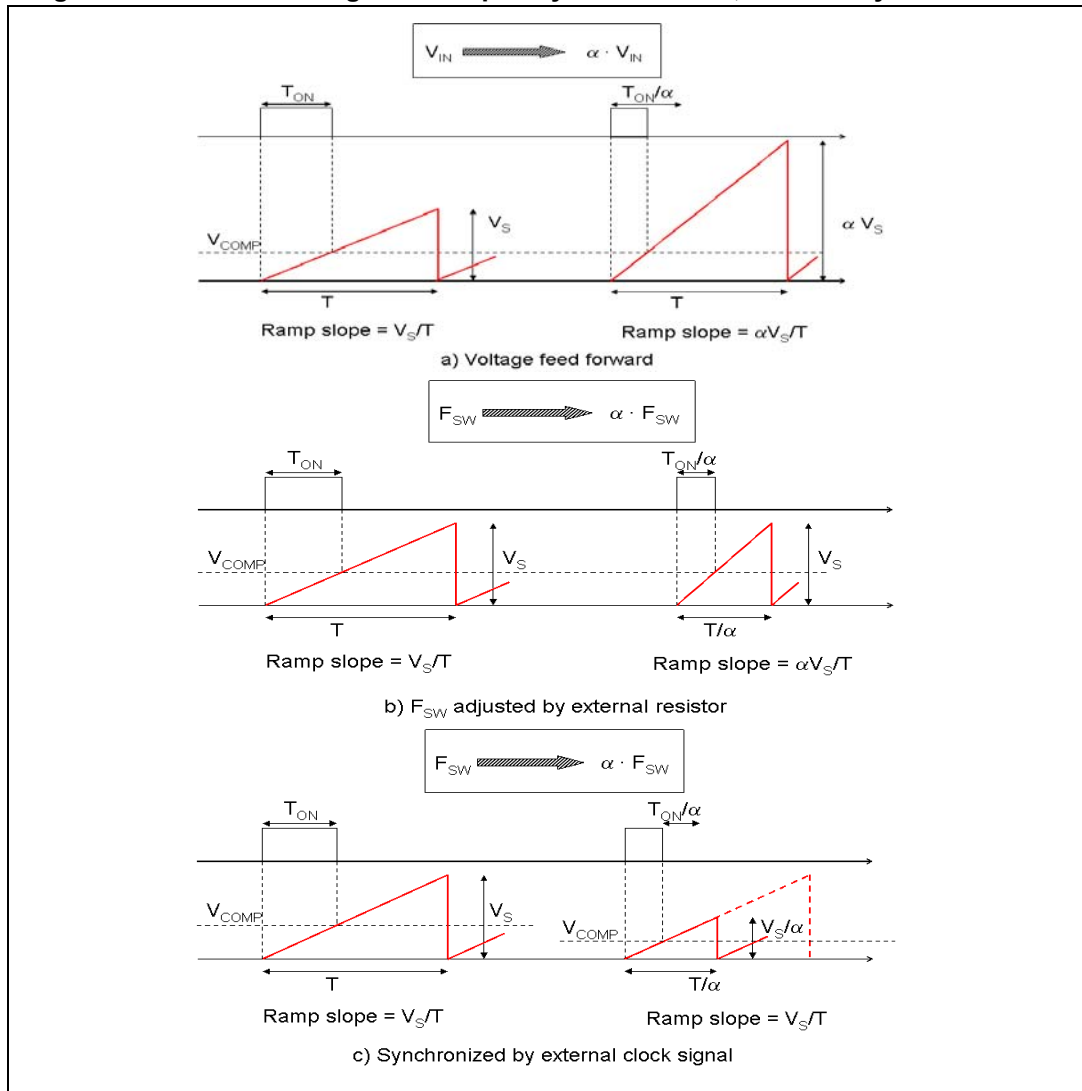
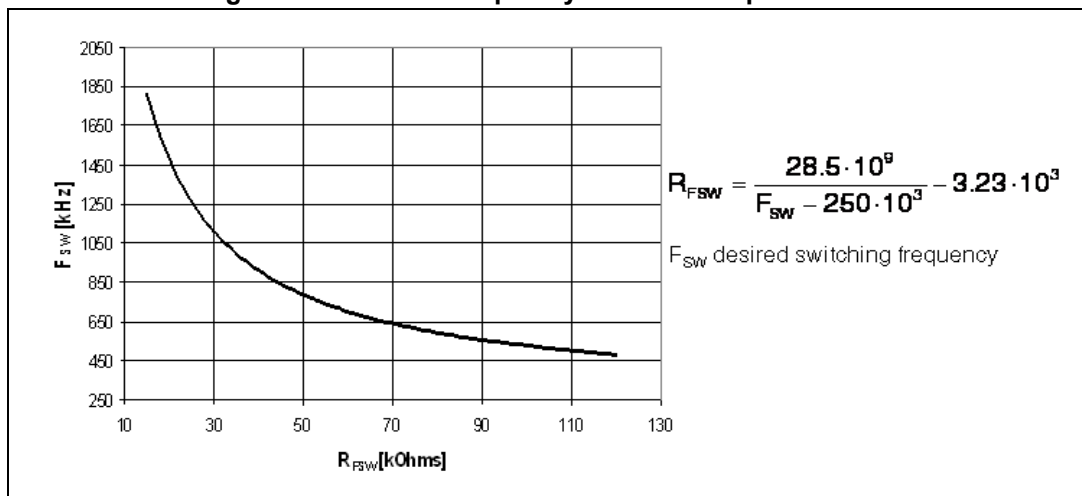

Figure 6. Oscillator frequency versus FSW pin resistor



5.2 Soft-start

The soft-start is essential to assure a correct and safe startup of the step-down converter. It avoids inrush current surge and makes the output voltage increases monotonically.

The soft-start is performed by a staircase ramp on the non inverting input (V_{REF}) of the error amplifier. So the output voltage slew rate is:

Equation 1

$$SR_{OUT} = SR_{VREF} \cdot \left(1 + \frac{R1}{R2}\right)$$

where SR_{VREF} is the slew rate of the non inverting input, while $R1$ and $R2$ is the resistor divider to regulate the output voltage (see [Figure 7](#)). The soft-start stair case consists of 64 steps of 9.5 mV each one, from 0 V to 0.6 V. The time base of one step is of 32 clock cycles. So the soft-start time and then the output voltage slew rate depend on the switching frequency.

Figure 7. Soft-start scheme

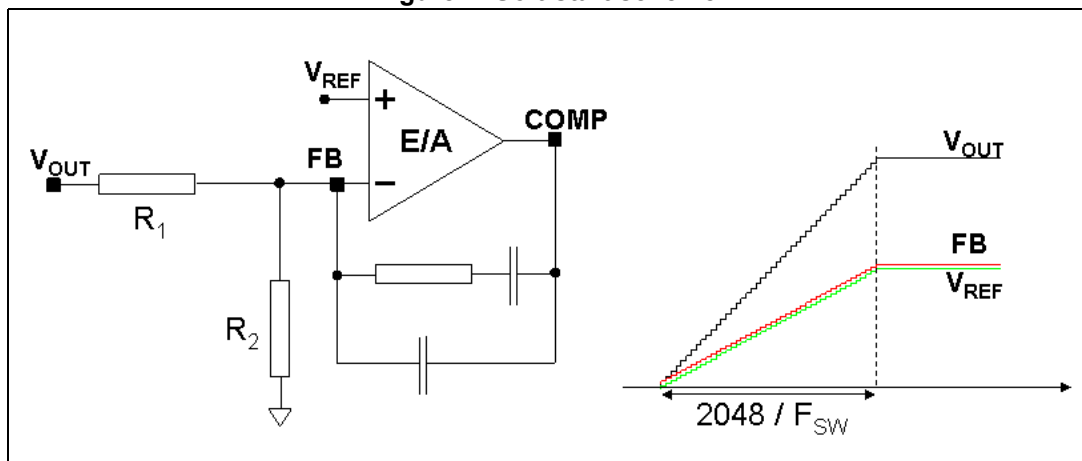

Soft-start time results:

Equation 2

$$SS_{TIME} = \frac{32 \cdot 64}{F_{SW}}$$

For example with a switching frequency of 250 kHz the SS_{TIME} is 8 ms.

5.3 Error amplifier and compensation

The error amplifier (E/A) provides the error signal to be compared with the sawtooth to perform the pulse width modulation. Its non inverting input is internally connected to a 0.6 V voltage reference, while its inverting input (FB) and output (COMP) are externally available for feedback and frequency compensation. In this device the error amplifier is a voltage mode operational amplifier so with high DC gain and low output impedance.

The uncompensated error amplifier characteristics are the following:

Table 5. Uncompensated error amplifier characteristics

Parameter	Value
Low frequency gain	100 dB
GBWP	4.5 MHz
Slew rate	7 V/ μ s
Output voltage swing	0 to 3.3 V
Maximum source/sink current	17 mA/25 mA

In continuous conduction mode (CCM), the transfer function of the power section has two poles due to the LC filter and one zero due to the ESR of the output capacitor. Different kinds of compensation networks can be used depending on the ESR value of the output capacitor. In case the zero introduced by the output capacitor helps to compensate the double pole of the LC filter a type II compensation network can be used. Otherwise, a type III compensation network has to be used (see [Section 6.4 on page 18](#) for details about the compensation network selection).

Anyway the methodology to compensate the loop is to introduce zeros to obtain a safe phase margin.

5.4 Overcurrent protection

The L7981 implements the overcurrent protection sensing current flowing through the Power MOSFET. Due to the noise created by the switching activity of the Power MOSFET, the current sensing is disabled during the initial phase of the conduction time. This avoids an erroneous detection of a fault condition. This interval is generally known as “masking time” or “blanking time”. The masking time is about 200 ns.

When the overcurrent is detected, two different behaviors are possible depending on the operating condition.

1. **Output voltage in regulation.** When the overcurrent is sensed, the Power MOSFET is switched off and the internal reference (V_{REF}), that biases the non inverting input of the error amplifier, is set to zero and kept in this condition for a soft-start time (T_{SS} , 2048 clock cycles). After this time, a new soft-start phase takes place and the internal reference begins ramping (see [Figure 8.a](#)).
2. **Soft-start phase.** If the overcurrent limit is reached the Power MOSFET is turned off implementing the pulse by pulse overcurrent protection. During the soft-start phase, under overcurrent condition, the device can skip pulses in order to keep the output current constant and equal to the current limit. If at the end of the “masking time” the current is higher than the overcurrent threshold, the Power MOSFET is turned off and it will skip one pulse. If, at the next switching on at the end of the “masking time” the current is still higher than the threshold, the device will skip two pulses. This mechanism is repeated and the device can skip up to seven pulses. While, if at the end of the “masking time” the current is lower than the overcurrent threshold, the number of skipped cycles is decreased of one unit. At the end of soft-start phase the output voltage is in regulation and if the overcurrent persists the behavior explained above takes place (see [Figure 8.b](#)).

So the overcurrent protection can be summarized as an “hiccup” intervention when the output is in regulation and a constant current during the soft-start phase. If the output is shorted to ground when the output voltage is on regulation, the overcurrent is triggered and the device starts cycling with a period of 2048 clock cycles between “hiccup” (Power MOSFET off and no current to the load) and “constant current” with very short on-time and with reduced switching frequency (up to one eighth of normal switching frequency). See [Figure 32 on page 33](#) for short-circuit behavior.

Figure 8. Overcurrent protection strategy

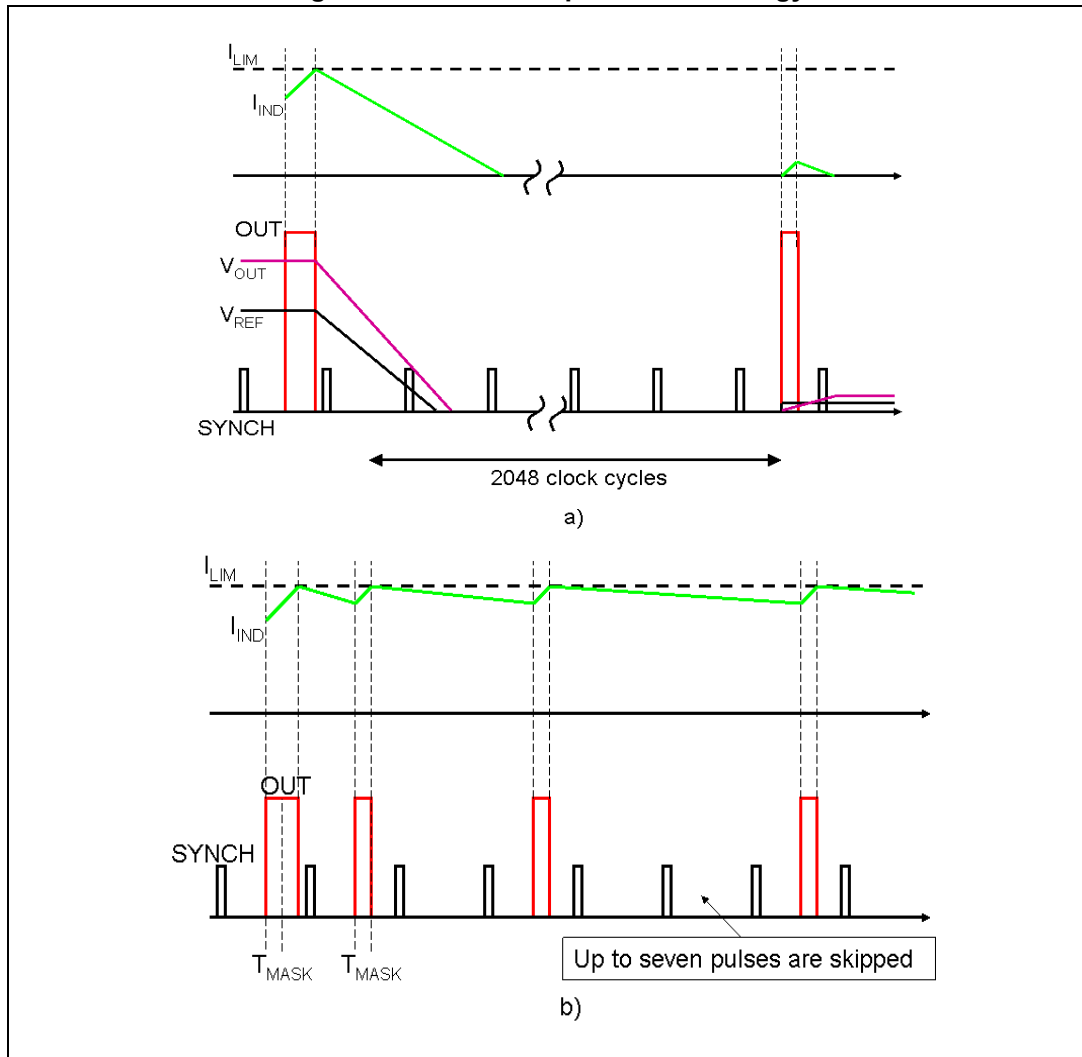

5.5 Enable function

The enable feature allows to put in standby mode the device. With the EN pin lower than 0.3 V the device is disabled and the power consumption is reduced to less than 30 μ A. With the EN pin lower than 1.2 V, the device is enabled. If the EN pin is left floating, an internal pull down ensures that the voltage at the pin reaches the inhibit threshold and the device is disabled. The pin is also V_{CC} compatible.

5.6 Hysteretic thermal shutdown

The thermal shutdown block generates a signal that turns off the power stage if the junction temperature goes above 150 $^{\circ}$ C. Once the junction temperature goes back to about 130 $^{\circ}$ C, the device restarts in normal operation. The sensing element is very close to the PDMOS area, so ensuring an accurate and fast temperature detection.

6 Application informations

6.1 Input capacitor selection

The capacitor connected to the input has to be capable to support the maximum input operating voltage and the maximum RMS input current required by the device. The input capacitor is subject to a pulsed current, the RMS value of which is dissipated over its ESR, affecting the overall system efficiency.

So the input capacitor must have an RMS current rating higher than the maximum RMS input current and an ESR value compliant with the expected efficiency.

The maximum RMS input current flowing through the capacitor can be calculated as:

Equation 3

$$I_{\text{RMS}} = I_{\text{O}} \cdot \sqrt{D - \frac{2 \cdot D^2}{\eta} + \frac{D^2}{\eta^2}}$$

Where I_{O} is the maximum DC output current, D is the duty cycle, η is the efficiency. Considering $\eta = 1$, this function has a maximum at $D = 0.5$ and it is equal to $I_{\text{O}}/2$.

In a specific application the range of possible duty cycles has to be considered in order to find out the maximum RMS input current. The maximum and minimum duty cycles can be calculated as:

Equation 4

$$D_{\text{MAX}} = \frac{V_{\text{OUT}} + V_{\text{F}}}{V_{\text{INMIN}} - V_{\text{SW}}}$$

and

Equation 5

$$D_{\text{MIN}} = \frac{V_{\text{OUT}} + V_{\text{F}}}{V_{\text{INMAX}} - V_{\text{SW}}}$$

Where V_{F} is the forward voltage on the freewheeling diode and V_{SW} is voltage drop across the internal PDMOS.

The peak to peak voltage across the input capacitor can be calculated as:

Equation 6

$$V_{\text{PP}} = \frac{I_{\text{O}}}{C_{\text{IN}} \cdot F_{\text{SW}}} \cdot \left[\left(1 - \frac{D}{\eta}\right) \cdot D + \frac{D}{\eta} \cdot (1 - D) \right] + \text{ESR} \cdot I_{\text{O}}$$

where ESR is the equivalent series resistance of the capacitor.

Given the physical dimension, ceramic capacitors can meet well the requirements of the input filter sustaining a higher input RMS current than electrolytic / tantalum types.

In this case the equation of C_{IN} as a function of the target V_{PP} can be written as follows:

Equation 7

$$C_{IN} = \frac{I_O}{V_{PP} \cdot F_{SW}} \cdot \left[\left(1 - \frac{D}{\eta}\right) \cdot D + \frac{D}{\eta} \cdot (1 - D) \right]$$

neglecting the small ESR of ceramic capacitors.

Considering $\eta = 1$, this function has its maximum in $D = 0.5$, thus, given the maximum peak to peak input voltage (V_{PP_MAX}), the minimum input capacitor (C_{IN_MIN}) value is:

Equation 8

$$C_{IN_MIN} = \frac{I_O}{2 \cdot V_{PP_MAX} \cdot F_{SW}}$$

Typically C_{IN} is dimensioned to keep the maximum peak-peak voltage in the order of 1% of V_{INMAX}

In [Table 6](#) some multi layer ceramic capacitors suitable for this device are reported.

Table 6. Input MLCC capacitors

Manufacture	Series	Cap value (μ F)	Rated voltage (V)
Taiyo Yuden	UMK325BJ106MM-T	10	50
	GMK325BJ106MN-T	10	35
Murata	GRM32ER71H475K	4.7	50

A ceramic bypass capacitor, as close to the VCC and GND pins as possible, so that additional parasitic ESR and ESL are minimized, is suggested in order to prevent instability on the output voltage due to noise. The value of the bypass capacitor can go from 100 nF to 1 μ F.

6.2 Inductor selection

The inductance value fixes the current ripple flowing through the output capacitor. So the minimum inductance value in order to have the expected current ripple has to be selected. The rule to fix the current ripple value is to have a ripple at 20% - 40% of the output current.

In the continuous current mode (CCM), the inductance value can be calculated by [Equation 9](#):

Equation 9

$$\Delta I_L = \frac{V_{IN} - V_{OUT}}{L} \cdot T_{ON} = \frac{V_{OUT} + V_F}{L} \cdot T_{OFF}$$

Where T_{ON} is the conduction time of the internal high-side switch and T_{OFF} is the conduction time of the external diode [in CCM, $F_{SW} = 1 / (T_{ON} + T_{OFF})$]. The maximum current ripple, at fixed V_{OUT} , is obtained at maximum T_{OFF} that is at minimum duty cycle (see [Section 6.1](#) to calculate minimum duty).

So fixing $\Delta I_L = 20\%$ to 30% of the maximum output current, the minimum inductance value can be calculated:

Equation 10

$$L_{\text{MIN}} = \frac{V_{\text{OUT}} + V_F}{\Delta I_{\text{MAX}}} \cdot \frac{1 - D_{\text{MIN}}}{F_{\text{SW}}}$$

where F_{SW} is the switching frequency, $1 / (T_{\text{ON}} + T_{\text{OFF}})$.

For example for $V_{\text{OUT}} = 5 \text{ V}$, $V_{\text{IN}} = 24 \text{ V}$, $I_{\text{O}} = 3 \text{ A}$ and $F_{\text{SW}} = 250 \text{ kHz}$ the minimum inductance value to have $\Delta I_L = 30\%$ of I_{O} is about $18 \mu\text{H}$.

The peak current through the inductor is given by:

Equation 11

$$I_{\text{L, PK}} = I_{\text{O}} + \frac{\Delta I_L}{2}$$

So if the inductor value decreases, the peak current (that has to be lower than the current limit of the device) increases. The higher is the inductor value, the higher is the average output current that can be delivered, without reaching the current limit.

In [Table 7](#) some inductor part numbers are listed.

Table 7. Inductors

Manufacturer	Series	Inductor value (μH)	Saturation current (A)
Coilcraft	MSS1038	3.8 to 10	3.9 to 6.5
	MSS1048	12 to 22	3.84 to 5.34
Würth	PD Type L	8.2 to 15	3.75 to 6.25
	PD Type M	2.2 to 4.7	4 to 6
SUMIDA	CDRH6D226/HP	1.5 to 3.3	3.6 to 5.2
	CDR10D48MN	6.6 to 12	4.1 to 5.7

6.3 Output capacitor selection

The current in the capacitor has a triangular waveform which generates a voltage ripple across it. This ripple is due to the capacitive component (charge or discharge of the output capacitor) and the resistive component (due to the voltage drop across its ESR). So the output capacitor has to be selected in order to have a voltage ripple compliant with the application requirements.

The amount of the voltage ripple can be calculated starting from the current ripple obtained by the inductor selection.

Equation 12

$$\Delta V_{\text{OUT}} = \text{ESR} \cdot \Delta I_{\text{MAX}} + \frac{\Delta I_{\text{MAX}}}{8 \cdot C_{\text{OUT}} \cdot f_{\text{SW}}}$$

Usually the resistive component of the ripple is much higher than the capacitive one, if the output capacitor adopted is not a multi layer ceramic capacitor (MLCC) with very low ESR value.

The output capacitor is important also for loop stability: it fixes the double LC filter pole and the zero due to its ESR. In [Section 6.4](#) it will be illustrated how to consider its effect in the system stability.

For example with $V_{OUT} = 5\text{ V}$, $V_{IN} = 24\text{ V}$, $\Delta I_L = 0.9\text{ A}$ (resulting by the inductor value), in order to have a $\Delta V_{OUT} = 0.01 \cdot V_{OUT}$, if the multi layer ceramic capacitor are adopted, $10\ \mu\text{F}$ are needed and the ESR effect on the output voltage ripple can be neglected. In case of not negligible ESR (electrolytic or tantalum capacitors), the capacitor is chosen taking into account its ESR value. So in case of $330\ \mu\text{F}$ with $\text{ESR} = 30\ \text{m}\Omega$, the resistive component of the drop dominates and the voltage ripple is $28\ \text{mV}$.

The output capacitor is also important to sustain the output voltage when a load transient with high slew rate is required by the load. When the load transient slew rate exceeds the system bandwidth the output capacitor provides the current to the load. So if the high slew rate load transient is required by the application the output capacitor and system bandwidth have to be chosen in order to sustain the load transient.

In [Table 8](#) some capacitor series are listed.

Table 8. Output capacitors

Manufacturer	Series	Cap value (μF)	Rated voltage (V)	ESR ($\text{m}\Omega$)
MURATA	GRM32	22 to 100	6.3 to 25	< 5
	GRM31	10 to 47	6.3 to 25	< 5
PANASONIC	ECJ	10 to 22	6.3	< 5
	EEFCD	10 to 68	6.3	15 to 55
SANYO	TPA/B/C	100 to 470	4 to 16	40 to 80
TDK	C3225	22 to 100	6.3	< 5

6.4 Compensation network

The compensation network has to assure stability and good dynamic performance. The loop of the L7981 is based on the voltage mode control. The error amplifier is a voltage operational amplifier with high bandwidth. So selecting the compensation network the E/A will be considered as ideal, that is, its bandwidth is much larger than the system one.

The transfer functions of PWM modulator and the output LC filter are studied (see [Figure 10](#)). The transfer function of the PWM modulator, from the error amplifier output (COMP pin) to the OUT pin, results:

Equation 13

$$G_{PWO} = \frac{V_{IN}}{V_S}$$

where V_S is the sawtooth amplitude.

Equation 18

$$Q = \frac{\sqrt{R_{OUT} \cdot L \cdot C_{OUT} \cdot (R_{OUT} + ESR)}}{L + C_{OUT} \cdot R_{OUT} \cdot ESR}, \quad R_{OUT} = \frac{V_{OUT}}{I_{OUT}}$$

As seen in [Section 5.3 on page 12](#) two different kind of network can compensate the loop. In the two following paragraph the guidelines to select the Type II and Type III compensation network are illustrated.

6.4.1 Type III compensation network

The methodology to stabilize the loop consists of placing two zeros to compensate the effect of the LC double pole, so increasing phase margin; then to place one pole in the origin to minimize the dc error on regulated output voltage; finally to place other poles far away the zero dB frequency.

If the equivalent series resistance (ESR) of the output capacitor introduces a zero with a frequency higher than the desired bandwidth (that is: $2\pi \cdot ESR \cdot C_{OUT} < 1 / BW$), the type III compensation network is needed. Multi layer ceramic capacitors (MLCC) have very low ESR ($< 1 \text{ m}\Omega$), with very high frequency zero, so type III network is adopted to compensate the loop.

In [Figure 10](#) the type III compensation network is shown. This network introduces two zeros (f_{Z1}, f_{Z2}) and three poles (f_{P0}, f_{P1}, f_{P2}). They are expressed as:

Equation 19

$$f_{Z1} = \frac{1}{2\pi \cdot C_3 \cdot (R_1 + R_3)}, \quad f_{Z2} = \frac{1}{2\pi \cdot R_4 \cdot C_4}$$

Equation 20

$$f_{P0} = 0, \quad f_{P1} = \frac{1}{2\pi \cdot R_3 \cdot C_3}, \quad f_{P2} = \frac{1}{2\pi \cdot R_4 \cdot \frac{C_4 \cdot C_5}{C_4 + C_5}}$$

Figure 10. Type III compensation network

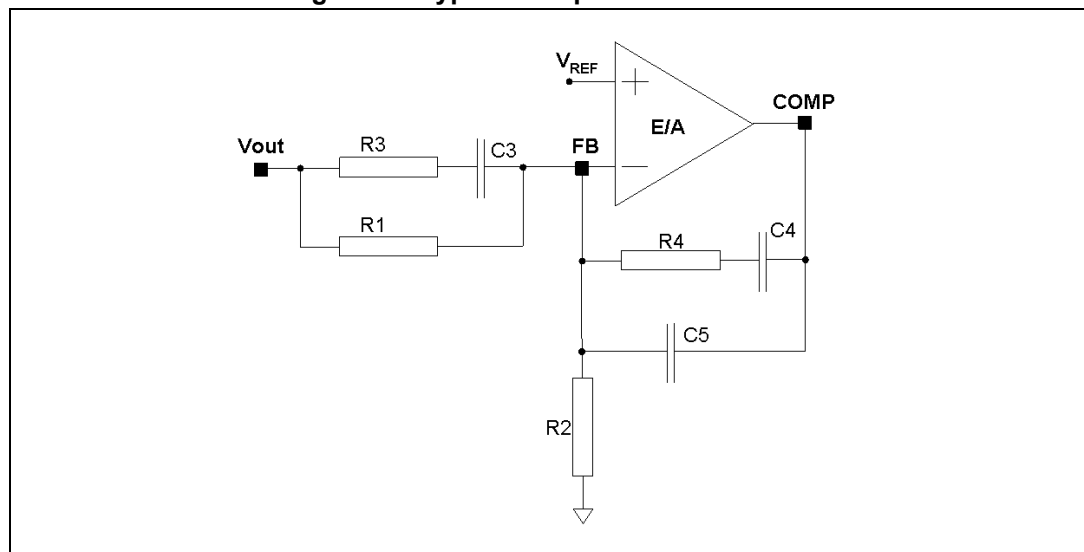

In [Figure 11](#) the Bode diagram of the PWM and LC filter transfer function [$G_{\text{PWM}} \cdot G_{\text{LC}}(f)$] and the open loop gain [$G_{\text{LOOP}}(f) = G_{\text{PWM}} \cdot G_{\text{LC}}(f) \cdot G_{\text{TypeIII}}(f)$] are drawn.

Figure 11. Open loop gain: module Bode diagram

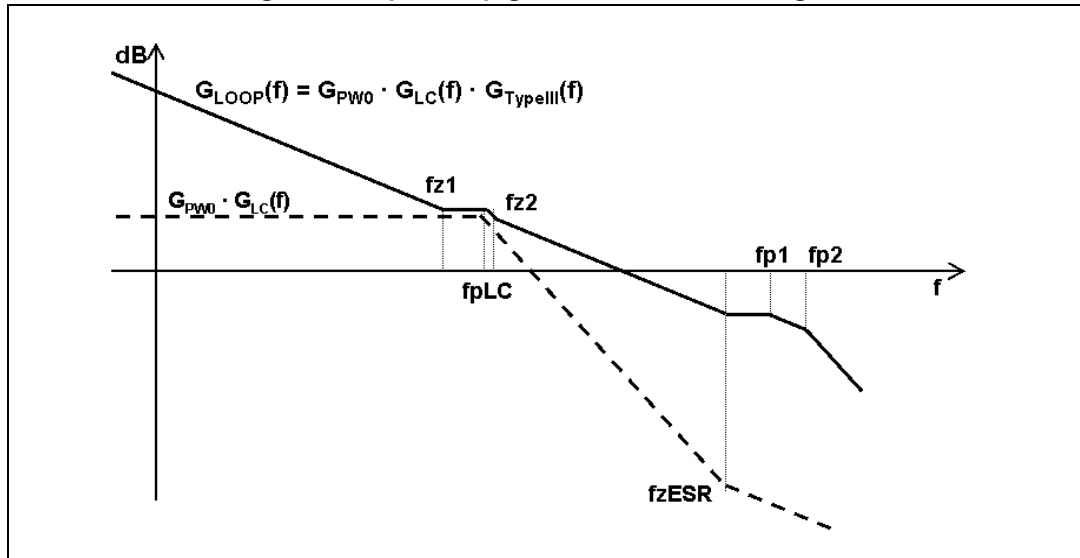

The guidelines for positioning the poles and the zeroes and for calculating the component values can be summarized as follow:

1. Choose a value for R_1 , usually between 1 k Ω and 5 k Ω .
2. Choose a gain (R_4 / R_1) in order to have the required bandwidth (BW), that means:

Equation 21

$$R_4 = \frac{BW}{f_{LC}} \cdot K \cdot R_1$$

where K is the feed forward constant and $1 / K$ is equals to 13.

3. Calculate C_4 by placing the zero at 50% of the output filter double pole frequency (f_{LC}):

Equation 22

$$C_4 = \frac{1}{\pi \cdot R_4 \cdot f_{LC}}$$

4. Calculate C_5 by placing the second pole at four times the system bandwidth (BW):

Equation 23

$$C_5 = \frac{C_4}{2\pi \cdot R_4 \cdot C_4 \cdot 4 \cdot BW - 1}$$

5. Set also the first pole at four times the system bandwidth and also the second zero at the output filter double pole:

Equation 24

$$R_3 = \frac{R_1}{\frac{4 \cdot BW}{f_{LC}} - 1}, \quad C_3 = \frac{1}{2\pi \cdot R_3 \cdot 4 \cdot BW}$$

The suggested maximum system bandwidth is equals to the switching frequency divided by 3.5 ($F_{SW} / 3.5$), anyway lower than 100 kHz if the F_{SW} is set higher than 500 kHz.

For example with $V_{OUT} = 5\text{ V}$, $V_{IN} = 24\text{ V}$, $I_O = 3\text{ A}$, $L = 18\text{ }\mu\text{H}$, $C_{OUT} = 22\text{ }\mu\text{F}$, $\text{ESR} < 1\text{ m}\Omega$, the type III compensation network is:

Equation 25

$$R_1 = 4.99\text{k}\Omega, \quad R_2 = 680\Omega, \quad R_3 = 200\Omega, \quad R_4 = 3.3\text{k}\Omega, \quad C_3 = 3.3\text{nF}, \quad C_4 = 22\text{nF}, \quad C_5 = 220\text{pF}$$

In [Figure 12](#) is shown the module and phase of the open loop gain. The bandwidth is about 58 kHz and the phase margin is 50°.

Figure 12. Open loop gain bode diagram with ceramic output capacitor

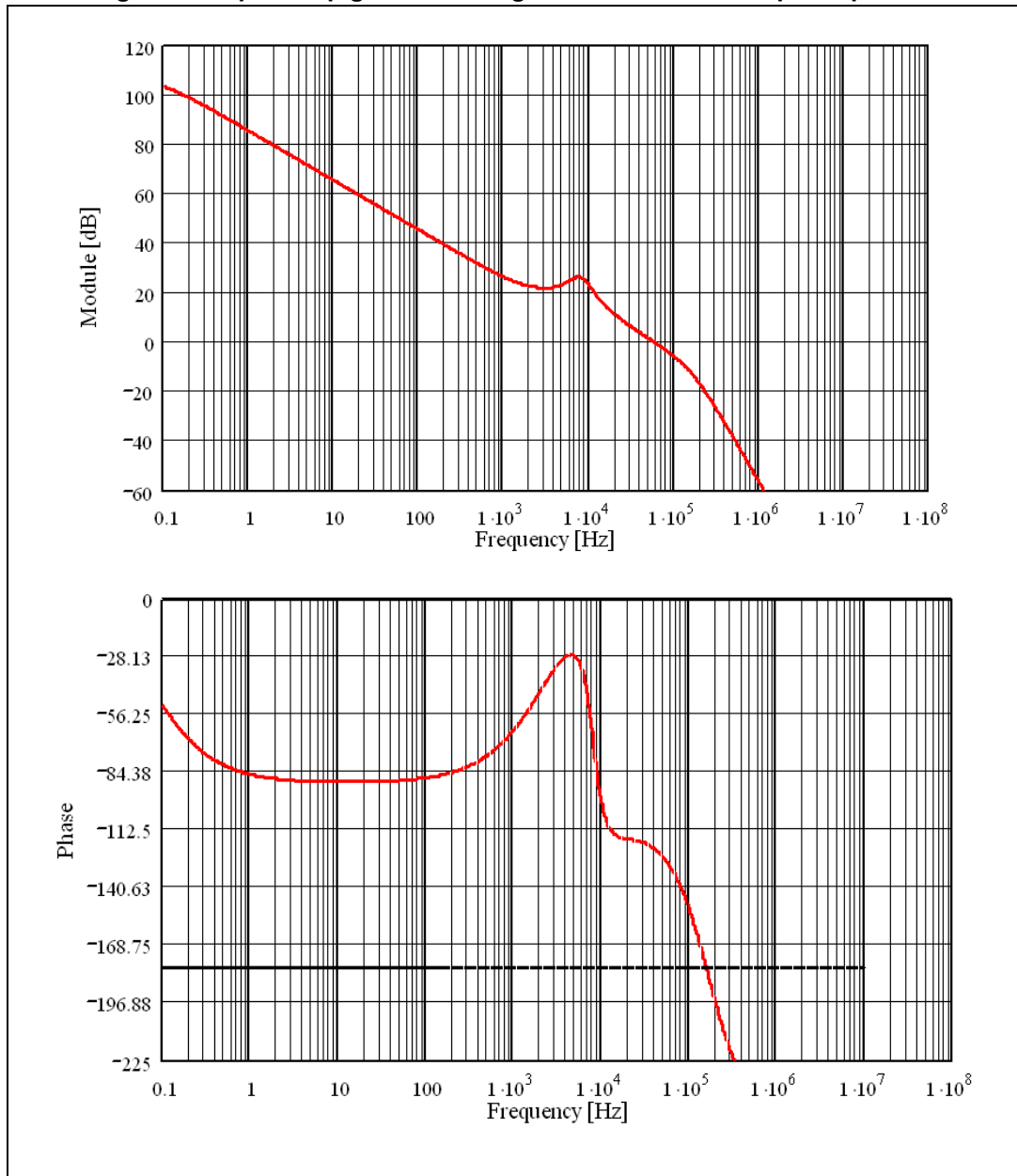

6.4.2 Type II compensation network

If the equivalent series resistance (ESR) of the output capacitor introduces a zero with a frequency lower than the desired bandwidth (that is: $2\pi \cdot \text{ESR} \cdot C_{\text{OUT}} > 1 / \text{BW}$), this zero helps stabilize the loop. Electrolytic capacitors show not negligible ESR ($> 30 \text{ m}\Omega$), so with this kind of output capacitor the type II network combined with the zero of the ESR allows stabilizing the loop.

In [Figure 13](#) the type II network is shown.

Figure 13. Type II compensation network

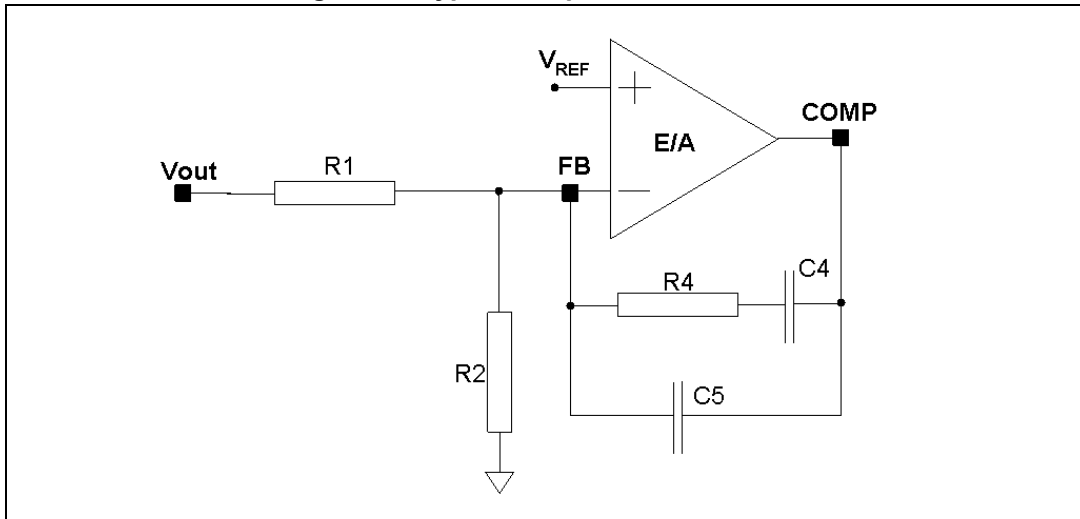

The singularities of the network are:

Equation 26

$$f_{z1} = \frac{1}{2\pi \cdot R_4 \cdot C_4}, \quad f_{p0} = 0, \quad f_{p1} = \frac{1}{2\pi \cdot R_4 \cdot \frac{C_4 \cdot C_5}{C_4 + C_5}}$$

In [Figure 14](#) the Bode diagram of the PWM and LC filter transfer function [$G_{\text{PW0}} \cdot G_{\text{LC}}(f)$] and the open loop gain [$G_{\text{LOOP}}(f) = G_{\text{PW0}} \cdot G_{\text{LC}}(f) \cdot G_{\text{TYPEII}}(f)$] are drawn.

Figure 14. Open loop gain: module bode diagram

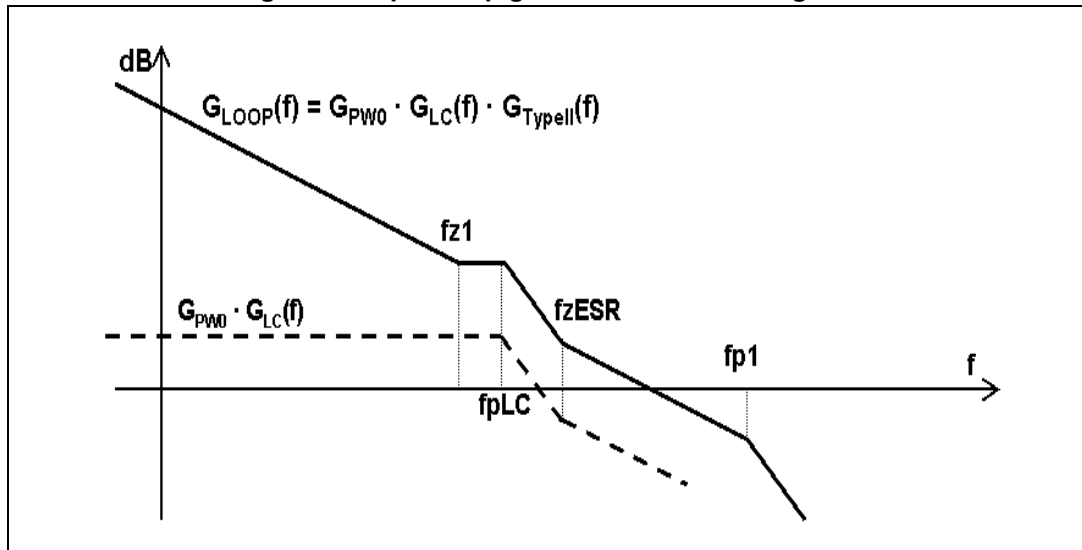

The guidelines for positioning the poles and the zeroes and for calculating the component values can be summarized as follow:

1. Choose a value for R_1 , usually between 1 k Ω and 5 k Ω , in order to have values of C_4 and C_5 not comparable with parasitic capacitance of the board.
2. Choose a gain (R_4 / R_1) in order to have the required bandwidth (BW), that means:

Equation 27

$$R_4 = \left(\frac{f_{ESR}}{f_{LC}} \right)^2 \cdot \frac{BW}{f_{ESR}} \cdot \frac{V_S}{V_{IN}} \cdot R_1$$

Where f_{ESR} is the ESR zero:

Equation 28

$$f_{ESR} = \frac{1}{2\pi \cdot ESR \cdot C_{OUT}}$$

and V_S is the saw-tooth amplitude. The voltage feed forward keeps the ratio V_S/V_{IN} constant.

3. Calculate C_4 by placing the zero one decade below the output filter double pole:

Equation 29

$$C_4 = \frac{10}{2\pi \cdot R_4 \cdot f_{LC}}$$

4. Then calculate C_3 in order to place the second pole at four times the system bandwidth (BW):

Equation 30

$$C_5 = \frac{C_4}{2\pi \cdot R_4 \cdot C_4 \cdot 4 \cdot BW - 1}$$