



Chipsmall Limited consists of a professional team with an average of over 10 year of expertise in the distribution of electronic components. Based in Hongkong, we have already established firm and mutual-benefit business relationships with customers from,Europe,America and south Asia,supplying obsolete and hard-to-find components to meet their specific needs.

With the principle of “Quality Parts,Customers Priority,Honest Operation,and Considerate Service”,our business mainly focus on the distribution of electronic components. Line cards we deal with include Microchip,ALPS,ROHM,Xilinx,Pulse,ON,Everlight and Freescale. Main products comprise IC,Modules,Potentiometer,IC Socket,Relay,Connector.Our parts cover such applications as commercial,industrial, and automotives areas.

We are looking forward to setting up business relationship with you and hope to provide you with the best service and solution. Let us make a better world for our industry!



Contact us

Tel: +86-755-8981 8866 Fax: +86-755-8427 6832

Email & Skype: info@chipsmall.com Web: www.chipsmall.com

Address: A1208, Overseas Decoration Building, #122 Zhenhua RD., Futian, Shenzhen, China



Current Transducer LA 150-P

For the electronic measurement of currents: DC, AC, pulsed..., with galvanic separation between the primary circuit and the secondary circuit.



$$I_{PN} = 150 \text{ A}$$



Electrical data

I_{PN}	Primary nominal rms current	150	A		
I_{PM}	Primary current, measuring range	0 .. ± 212	A		
R_M	Measuring resistance @ 85 °C	$R_{M \min}$	$R_{M \max}$		
		with $\pm 12 \text{ V}$	@ $\pm 150 \text{ A}_{\max}$	0	40
		@ $\pm 212 \text{ A}_{\max}$	0	3	Ω
	with $\pm 15 \text{ V}$	@ $\pm 150 \text{ A}_{\max}$	0	78	Ω
	@ $\pm 212 \text{ A}_{\max}$	0	30	Ω	
I_{SN}	Secondary nominal rms current	75	mA		
K_N	Conversion ratio	1 : 2000			
U_C	Supply voltage ($\pm 5 \%$)	$\pm 12 \dots 15$	V		
I_C	Current consumption	10 (@ $\pm 15 \text{ V}$) + I_S	mA		

Accuracy - Dynamic performance data

X	Accuracy @ I_{PN} , $T_A = 25 \text{ °C}$	<0.5	%	
ϵ_L	Linearity error	<0.1	%	
I_{OE}	Electrical offset current @ $I_P = 0$, $T_A = 25 \text{ °C}$	Typ	Max	
			± 0.10	mA
I_{OM}	Magnetic offset current @ $I_P = 0$ and specified R_M , after an overload of $3 \times I_{PN}$		± 0.25	mA
			± 0.30	mA
I_{OT}	Temperature variation of I_O -40 °C .. +85 °C	± 0.15	mA	
t_{ra}	Reaction time	<300	ns	
t_r	Step response time ¹⁾ to 90 % of I_{PN}	<500	ns	
di/dt	di/dt accurately followed	>100	A/ μs	
BW	Frequency bandwidth (-1 dB)	DC .. 150	kHz	

General data

T_A	Ambient operating temperature	-40 .. +85	°C
T_S	Ambient storage temperature	-40 .. +90	°C
R_S	Resistance of secondary winding @ $T_A = 25 \text{ °C}$	64 \pm 2	Ω
m	Mass	<25	g
	Standards	EN 50178: 1997 UL 508: 2010	

Features

- Closed loop (compensated) current transducer using the Hall effect
- Insulating plastic case recognized according to UL 94-V0.

Advantages

- Excellent accuracy
- Very good linearity
- Low temperature drift
- Optimized response time
- Wide frequency bandwidth
- No insertion losses
- High immunity to external interference
- Current overload capability.

Applications

- AC variable speed drives and servo motor drives
- Static converters for DC motor drives
- Battery supplied applications
- Uninterruptible Power Supplies (UPS)
- Switched Mode Power Supplies (SMPS)
- Power supplies for welding applications.

Application domain

- Industrial.

Note: ¹⁾ With a di/dt of 100 A/ μs .

UL 508:Ratings and assumptions of certification LA 150-P

File # E189713 Volume: 2 Section: 1

Standards

- CSA C22.2 NO. 14 - 10 INDUSTRIAL CONTROL EQUIPMENT - Edition 11 - Revision Date 2011/08/01
- UL 508 STANDARD FOR INDUSTRIAL CONTROL EQUIPMENT - Edition 17 - Revision Date 2010/04/15.

Parameter	Symbol	Unit	Value
Primary potential involved		V AC/DC	600
Max surrounding air temperature	T_A	°C	85
Primary current	I_P	A	0 to 150
Secondary supply voltage	U_C	V DC	±12 .. 15
Output signal	I_{SN}	mA	75

Conditions of acceptability

When installed in the end-use equipment, consideration shall be given to the following:

- 1 - *These devices must be mounted in a suitable end-use enclosure.*
- 2 - *The terminals have not been evaluated for field wiring.*
- 3 - *The LA 150 series are intended to be mounted on the printed wiring board of the end-use equipment (with a minimum CTI of 100).*
- 4 - *Low voltage circuits are intended to be powered by a circuit derived from an isolating source (such as a transformer, optical isolator, limiting impedance or electro-mechanical relay) and having no direct connection back to the primary circuit (other than through the grounding means).*
- 5 - *Base on results of temperature tests, in the end use application, a maximum of 100 °C cannot be exceeded at soldering point between primary coil pin and soldering point of on the primary bus bar (corrected to the appropriate evaluated max. surrounding air).*

Marking

Only those products bearing the UL or UR Mark should be considered to be Listed or Recognized and covered under UL's Follow-Up Service. Always look for the Mark on the product.

Current Transducer LA 150-P

Insulation coordination

U_d	Rms voltage for AC insulation test, 50 Hz/1 min	4.3	kV
\hat{U}_W	Impulse withstand voltage 1.2/50 μ s	8	kV
U_e	Partial discharge extinction rms voltage @ 10 pC	1.3	kV
		Min	
d_{Cp}	Creepage distance	8	mm
d_{Cl}	Clearance	8	mm
CTI	Comparative tracking index (group I)	600	

Applications examples

According to EN 50178 and IEC 61010-1 standards and following conditions:

- Over voltage category OV 3
- Pollution degree PD2
- Non-uniform field

	EN 50178	IEC 61010-1
$d_{Cp}, d_{Cl}, \hat{U}_W$	Rated insulation voltage	Nominal voltage
Basic insulation	1000 V	1000 V
Reinforced insulation	600 V	400 V

Safety

This transducer must be used in limited-energy secondary circuits according to IEC 61010-1.



This transducer must be used in electric/electronic equipment with respect to applicable standards and safety requirements in accordance with the manufacturer's operating instructions.



Caution, risk of electrical shock

When operating the transducer, certain parts of the module can carry hazardous voltage (eg. primary busbar, power supply).

Ignoring this warning can lead to injury and/or cause serious damage.

This transducer is a build-in device, whose conducting parts must be inaccessible after installation.

A protective housing or additional shield could be used.

Main supply must be able to be disconnected.

Dimensions LA 150-P (in mm)

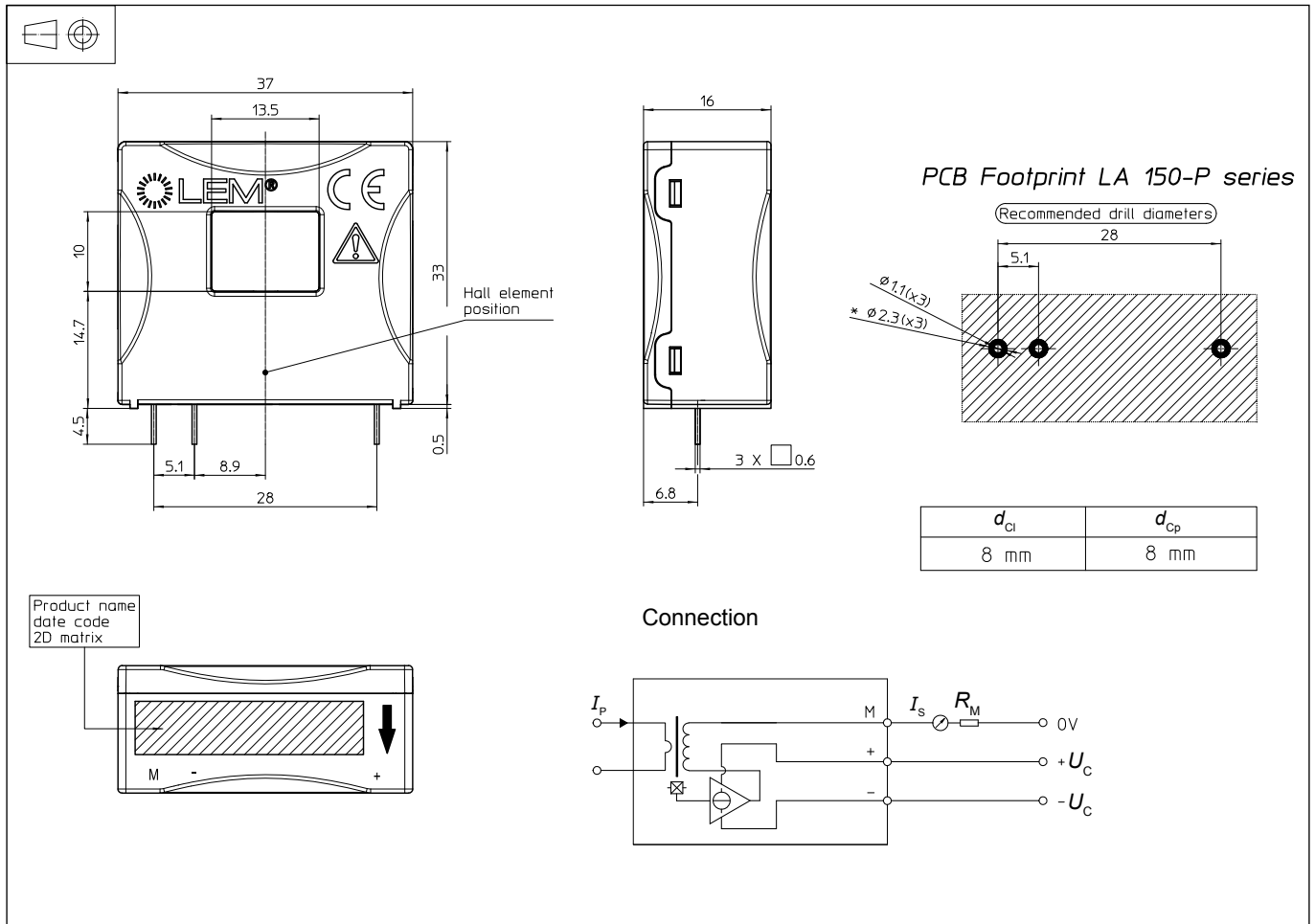

Mechanical characteristics

- General tolerance ± 0.5 mm
- Primary through-hole 13.5×10 mm
- Fastening & connection of secondary 3 pins 0.6×0.6 mm
Recommended PCB hole $\varnothing 1.1$ mm

Remarks

- I_s is positive when I_p flows in the direction of the arrow.
- Temperature of the primary conductor should not exceed 100°C .
- Installation of the transducer must be done unless otherwise specified on the datasheet, according to LEM Transducer Generic Mounting Rules. Please refer to LEM document N°ANE120504 available on our Web site: [Products/Product Documentation](#).
- Dynamic performances (di/dt and response time) are best with a single bar completely filling the primary hole.
- This is a standard model. For different versions (supply voltages, turns ratios, unidirectional measurements...), please contact us.