



Chipsmall Limited consists of a professional team with an average of over 10 year of expertise in the distribution of electronic components. Based in Hongkong, we have already established firm and mutual-benefit business relationships with customers from,Europe,America and south Asia,supplying obsolete and hard-to-find components to meet their specific needs.

With the principle of "Quality Parts,Customers Priority,Honest Operation,and Considerate Service",our business mainly focus on the distribution of electronic components. Line cards we deal with include Microchip,ALPS,ROHM,Xilinx,Pulse,ON,Everlight and Freescale. Main products comprise IC,Modules,Potentiometer,IC Socket,Relay,Connector.Our parts cover such applications as commercial,industrial, and automotives areas.

We are looking forward to setting up business relationship with you and hope to provide you with the best service and solution. Let us make a better world for our industry!



Contact us

Tel: +86-755-8981 8866 Fax: +86-755-8427 6832

Email & Skype: info@chipsmall.com Web: www.chipsmall.com

Address: A1208, Overseas Decoration Building, #122 Zhenhua RD., Futian, Shenzhen, China



LA0151CS

Ambient Light Sensor, Linear Current Output, with 2-Stage Gain Switching



ON Semiconductor[®]
www.onsemi.com

Overview

The LA0151CS is a photo IC for ultra-small package ambient light sensor. It enables to be mounted on a very small limited space such as on the mobile phones which is becoming small and thinner and on other mobile applications.

Features

- Linear current output
- Low gain mode function [low gain : -35dB]

Typical Applications

- Mobile phones and tablets
- Digital still cameras
- Security camera

SPECIFICATION

ABSOLUTE MAXIMUM RATINGS at Ta = 25°C (Note 1)

Parameter	Symbol	Conditions	Ratings	Unit
Maximum supply voltage	V _{CC}		6	V
Operating temperature	T _{opr}		-30 to +85	°C
Storage temperature	T _{stg}		-40 to +100	°C

1. Stresses exceeding those listed in the Absolute Maximum Rating table may damage the device. If any of these limits are exceeded, device functionality should not be assumed, damage may occur and reliability may be affected.

RECOMMENDED OPERATING CONDITIONS AND

OPERATING VOLTAGE RANGE at Ta = 25°C (Note 2)

Parameter	Symbol	Conditions	Ratings			Unit
			min	typ	max	
Recommended supply voltage	V _{CC}		2.2	3.3	5.5	V
SW pin low voltage	V _l	Normal gain mode	0		0.4	V
SW pin high voltage	V _h	Low gain mode	2.1			V

2. Functional operation above the stresses listed in the Recommended Operating Ranges is not implied. Extended exposure to stresses beyond the Recommended Operating Ranges limits may affect device reliability.

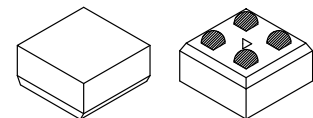

ODCSP4 1.01 mm x 1.01 mm

ORDERING INFORMATION

Ordering Code:
LA0151CS-TLM-E

Package
ODCSP4
(Pb-Free / Halogen Free)

Shipping (Qty / packing)
5000 / Tape & Reel

† For information on tape and reel specifications, including part orientation and tape sizes, please refer to our Tape and Reel Packaging Specifications Brochure, BRD8011/D.
http://www.onsemi.com/pub_link/Collateral/BRD8011-D.PDF

LA0151CS

ELECTRICAL AND OPTICAL CHARACTERISTICS at $T_a = 25^\circ\text{C}$, $V_{CC} = 3.3\text{V}$ (Note 3)

Parameter	Symbol	Conditions	Ratings			Unit
			min	typ	max	
Current dissipation (1) (Note 5, 7)	I_{CC}	$E_v = 1000 \text{ lx}$, $R_L = 5\text{k}\Omega$, N mode	90	150	210	μA
Current dissipation (2) (Note 5, 7)	I_{CC}	$E_v = 1000 \text{ lx}$, $R_L = 5\text{k}\Omega$, L mode	42	70	98	μA
Output current (1) (Note 5, 7)	I_{O1}	$E_v = 100 \text{ lx}$, N mode	6	8	10	μA
Output current (2) (Note 5, 7)	I_{O2}	$E_v = 1000 \text{ lx}$, N mode	60	80	100	μA
Output current (3) (Note 5, 7)	I_{O3}	$E_v = 100 \text{ lx}$, L mode	0.12	0.16	0.2	μA
Output current (4) (Note 5, 7)	I_{O4}	$E_v = 1000 \text{ lx}$, L mode	1.2	1.6	2.0	μA
Dark current	I_{leak}	$E_v = 0 \text{ lx}$, N mode, L mode			0.1	μA
Temperature coefficient (Note 6)	I_{tc}	$E_v = 100 \text{ lx}$, N mode, L mode, $T_a = -20 \text{ to } 60^\circ\text{C}$		0.34		$\%/\text{C}$
Rise time (1) (Note 8)	T_{r1}	$E_v = 1000 \text{ lx}$, $R_L = 5\text{k}\Omega$, N mode		15	40	μs
Rise time (2) (Note 8)	T_{r2}	$E_v = 1000 \text{ lx}$, $R_L = 500\text{k}\Omega$, L mode		20	50	μs
Fall time (1) (Note 8)	T_{f1}	$E_v = 1000 \text{ lx}$, $R_L = 5\text{k}\Omega$, N mode		150	500	μs
Fall time (2) (Note 8)	T_{f2}	$E_v = 1000 \text{ lx}$, $R_L = 500\text{k}\Omega$, L mode		150	500	μs
Peak sensitivity wave length (Note 6)	λ_p			550		nm
Saturation output voltage (Note 9)	V_O	$E_v = 1000 \text{ lx}$, $R_L = 150\text{k}\Omega$, N mode	3.0	3.2		V

3. Product parametric performance is indicated in the Electrical Characteristics for the listed test conditions, unless otherwise noted. Product performance may not be indicated by the Electrical Characteristics if operated under different conditions.

4. N mode and L mode stand for the normal gain mode and the low gain mode, respectively.

5. Measured with the standard light source A. White LED is used instead in the mass production line.

6. Design guaranteed item

7. Test circuit for measuring current dissipation and output current

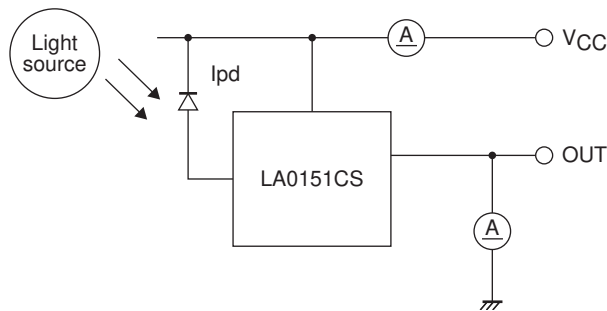

8. Measuring method of rise time (T_r) and fall time (T_f)

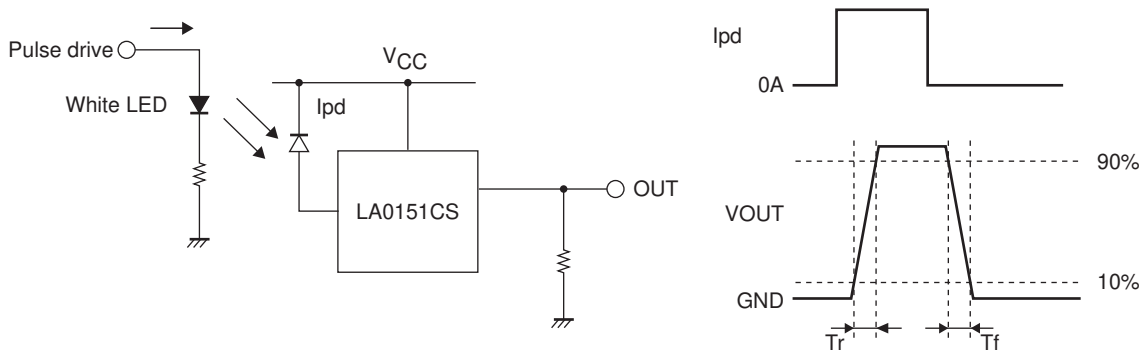

9. Reference value : min = 2.6V and typ = 2.8V when $V_{CC} = 2.9\text{V}$

LA0151CS

PAD LAYOUT

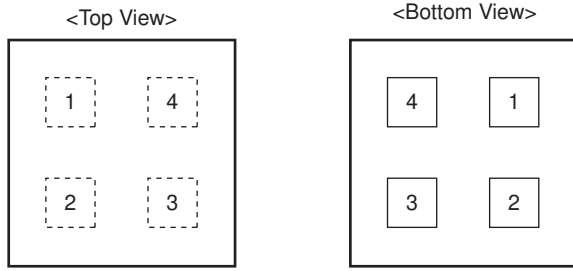

Pin No.	Pin Name	Function
1	VCC	Power supply
2	SW	Switch
3	GND	Ground
4	OUT	Output

Ball pitch : 0.5mm, Ball size : 0.18mm □

PAD LAYOUT (Photos)

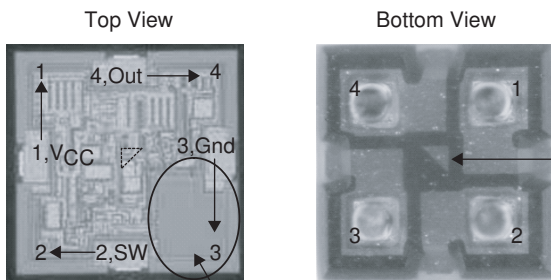

Pin 1 mark
It is located at the center of the bottom of the package.

Photo diode. Only this part looks dark on the product.

* The photo diode is located in pin 3. Be careful not to mistake the pin 1 mark for the photo diode.

INTRNAL BLOCK DIAGRAM

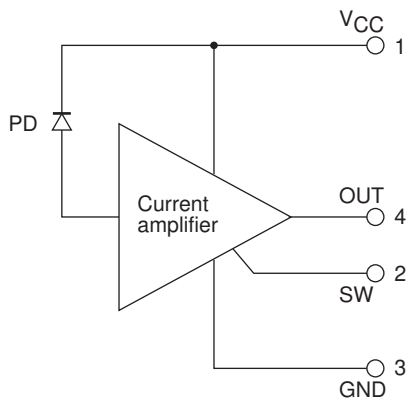

LA0151CS

CHIP PATTERN AND PHOTO-RECEIVING PATTERN DIAGRAMS

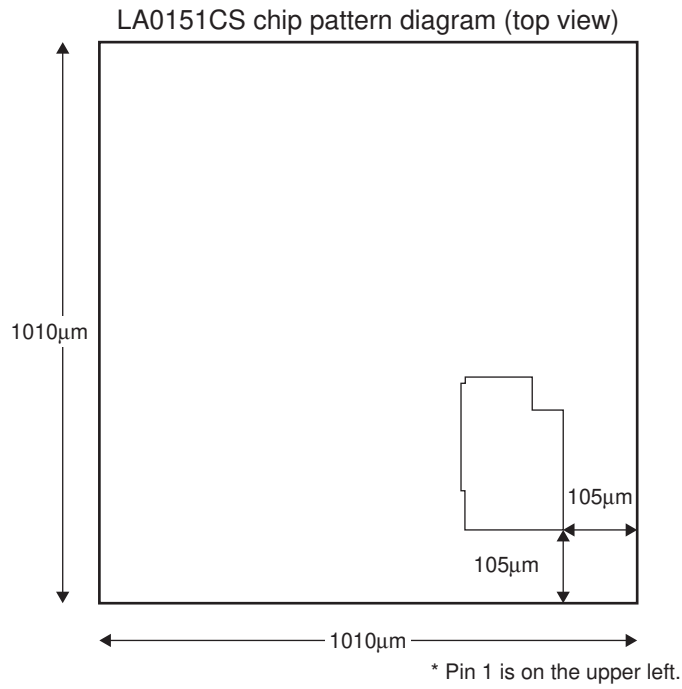

LA0151CS photo-receiving pattern enlarged diagram (effective area)

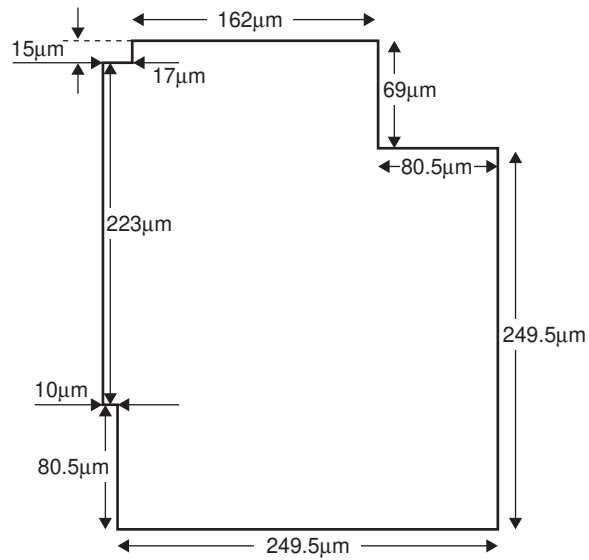

LA0151CS

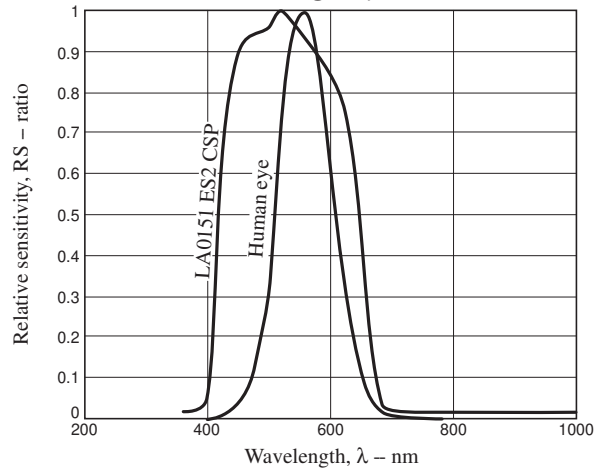
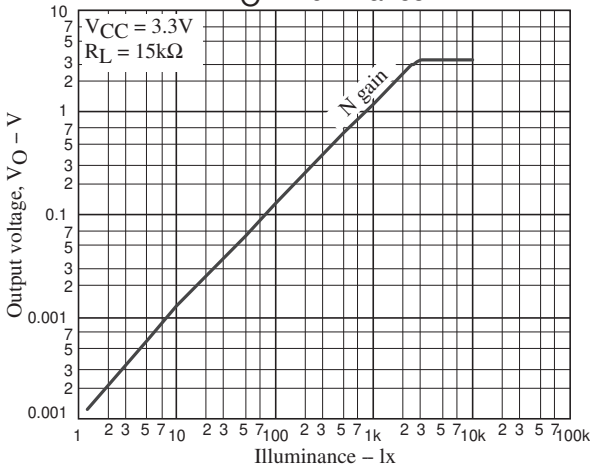
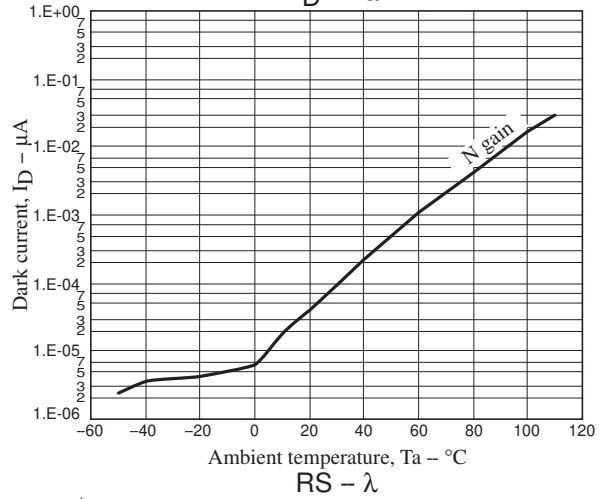
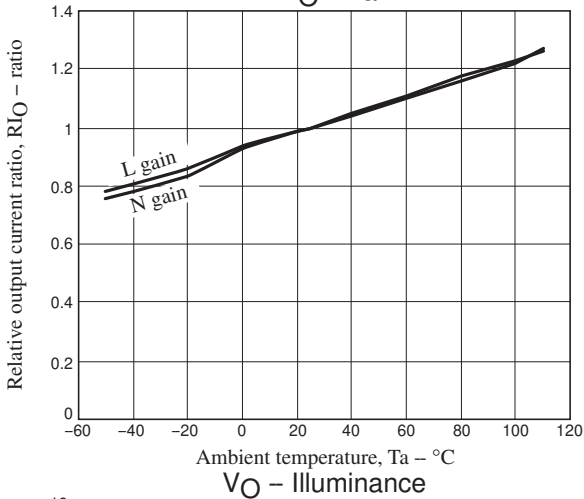
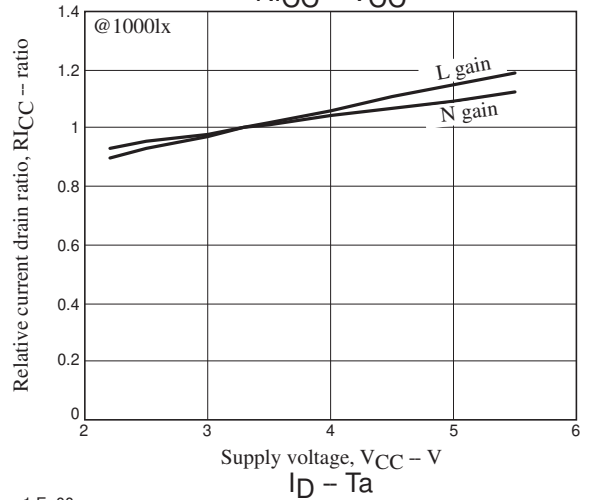
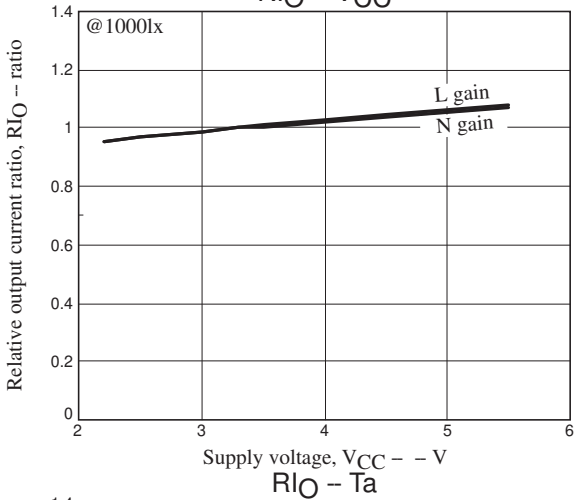
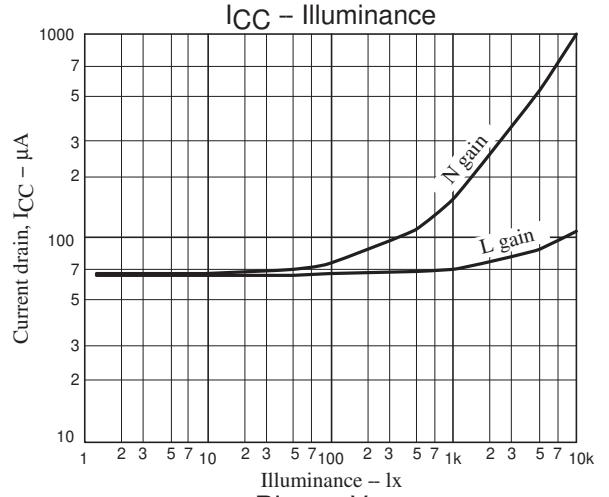
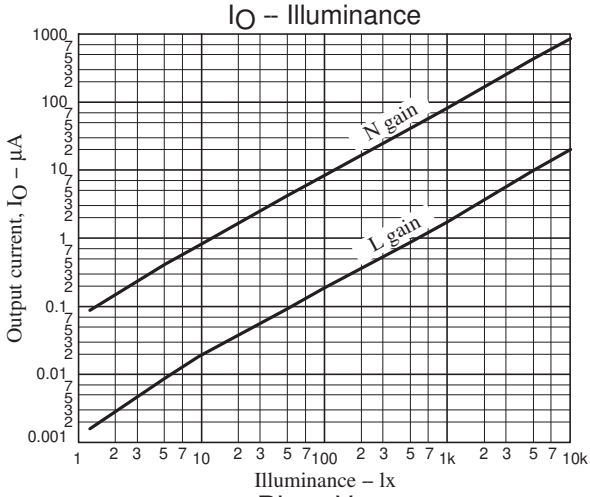

LA0151CS

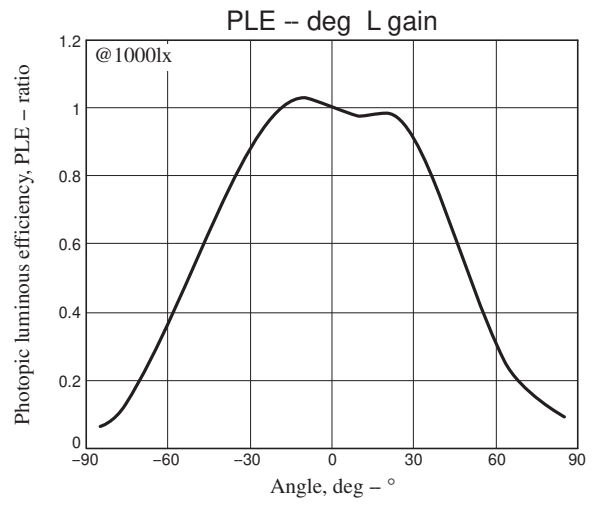
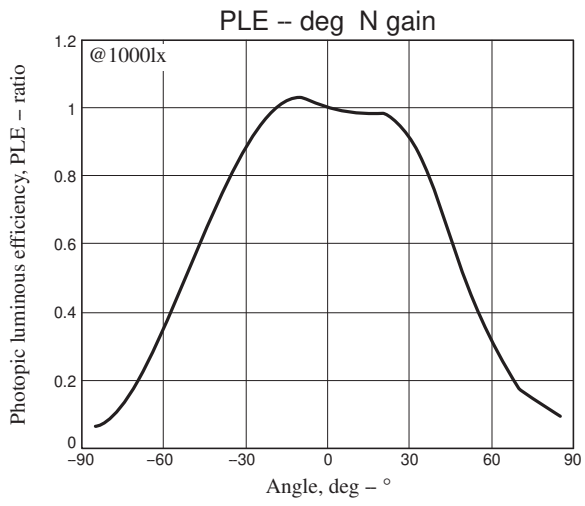

LA0151CS

PACKAGE DIMENSIONS

unit : mm

ODCSP4 1.01x1.01

CASE 570AC

ISSUE O

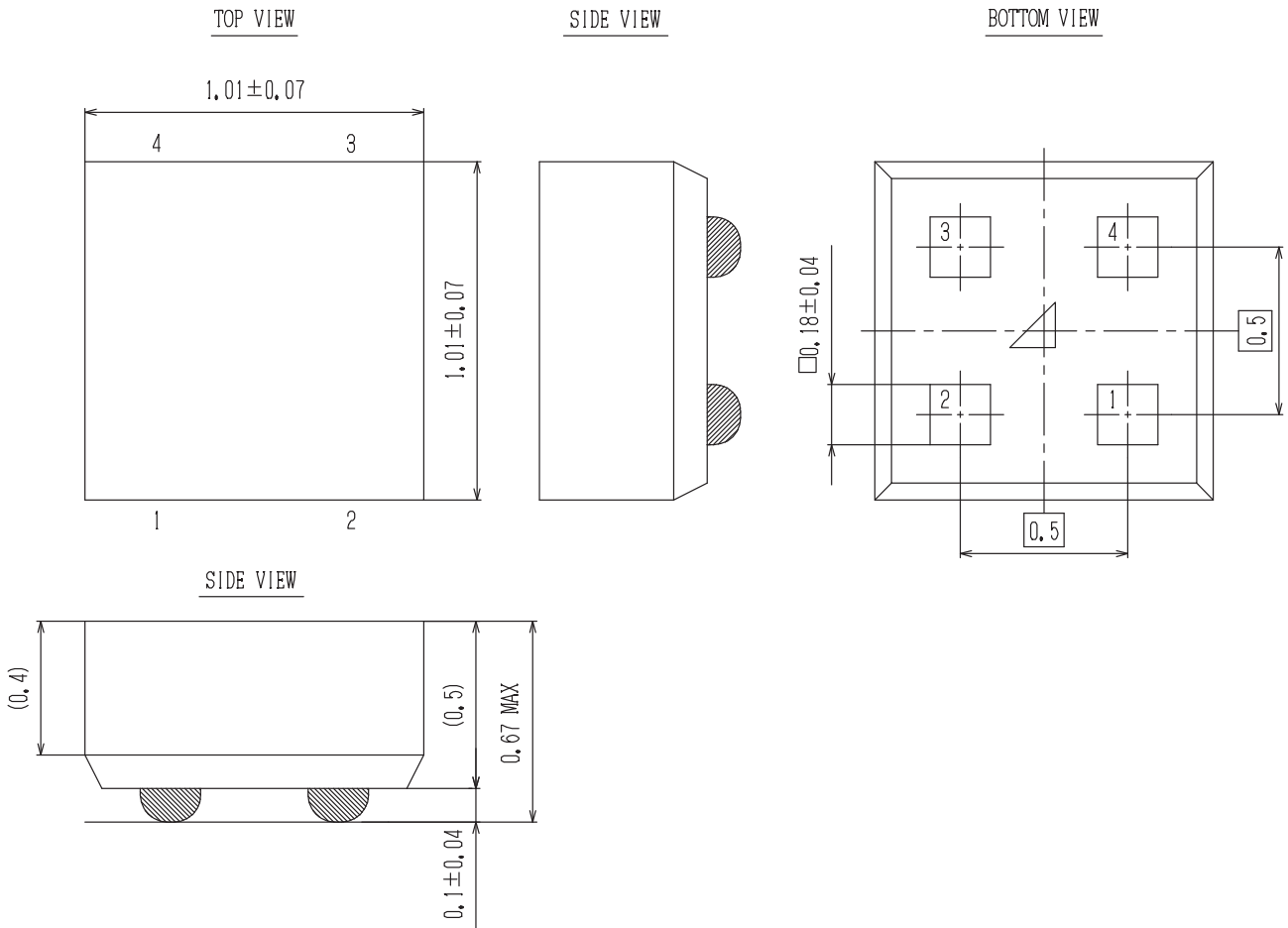

ON Semiconductor and the ON logo are registered trademarks of Semiconductor Components Industries, LLC (SCILLC) or its subsidiaries in the United States and/or other countries. SCILLC owns the rights to a number of patents, trademarks, copyrights, trade secrets, and other intellectual property. A listing of SCILLC's product/patent coverage may be accessed at www.onsemi.com/site/pdf/Patent-Marking.pdf. SCILLC reserves the right to make changes without further notice to any products herein. SCILLC makes no warranty, representation or guarantee regarding the suitability of its products for any particular purpose, nor does SCILLC assume any liability arising out of the application or use of any product or circuit, and specifically disclaims any and all liability, including without limitation special, consequential or incidental damages. "Typical" parameters which may be provided in SCILLC data sheets and/or specifications can and do vary in different applications and actual performance may vary over time. All operating parameters, including "Typicals" must be validated for each customer application by customer's technical experts. SCILLC does not convey any license under its patent rights nor the rights of others. SCILLC products are not designed, intended, or authorized for use as components in systems intended for surgical implant into the body, or other applications intended to support or sustain life, or for any other application in which the failure of the SCILLC product could create a situation where personal injury or death may occur. Should Buyer purchase or use SCILLC products for any such unintended or unauthorized application, Buyer shall indemnify and hold SCILLC and its officers, employees, subsidiaries, affiliates, and distributors harmless against all claims, costs, damages, and expenses, and reasonable attorney fees arising out of, directly or indirectly, any claim of personal injury or death associated with such unintended or unauthorized use, even if such claim alleges that SCILLC was negligent regarding the design or manufacture of the part. SCILLC is an Equal Opportunity/Affirmative Action Employer. This literature is subject to all applicable copyright laws and is not for resale in any manner.