



Chipsmall Limited consists of a professional team with an average of over 10 year of expertise in the distribution of electronic components. Based in Hongkong, we have already established firm and mutual-benefit business relationships with customers from,Europe,America and south Asia,supplying obsolete and hard-to-find components to meet their specific needs.

With the principle of “Quality Parts,Customers Priority,Honest Operation,and Considerate Service”,our business mainly focus on the distribution of electronic components. Line cards we deal with include Microchip,ALPS,ROHM,Xilinx,Pulse,ON,Everlight and Freescale. Main products comprise IC,Modules,Potentiometer,IC Socket,Relay,Connector.Our parts cover such applications as commercial,industrial, and automotives areas.

We are looking forward to setting up business relationship with you and hope to provide you with the best service and solution. Let us make a better world for our industry!



## Contact us

Tel: +86-755-8981 8866 Fax: +86-755-8427 6832

Email & Skype: info@chipsmall.com Web: www.chipsmall.com

Address: A1208, Overseas Decoration Building, #122 Zhenhua RD., Futian, Shenzhen, China





SANYO Semiconductors

## DATA SHEET

# LA4537M

Monolithic Linear IC  
Power Amplifier For 1.5V Headphone Stereos

## Features

- Low current drain
- 16Ω load drive capability
- Excellent reduced voltage characteristics
- Excellent power supply ripple rejection
- Minimum number of external parts required (no input capacitor, feedback capacitor required)
- Less harmonic interference in radio band
- On-chip power switch function, muting function

## Specifications

### Absolute Maximum Ratings at Ta = 25°C

Parameter	Symbol	Conditions	Ratings	Unit
Maximum supply voltage	V <sub>CC</sub> max	Quiescent	4.5	V
Allowable power dissipation	P <sub>d</sub> max		300	mW
Operating temperature	T <sub>opr</sub>		-20 to +75	°C
Storage temperature	T <sub>stg</sub>		-40 to +125	°C

### Operating Conditions at Ta = 25°C

Parameter	Symbol	Conditions	Ratings	Unit
Recommended supply voltage	V <sub>CC</sub>		1.5	V
Operating voltage range	V <sub>CC op</sub>		0.9 to 4.0	V
Recommended load resistance	R <sub>L</sub>		16 to 32	Ω

■ Any and all SANYO Semiconductor Co.,Ltd. products described or contained herein are, with regard to "standard application", intended for the use as general electronics equipment (home appliances, AV equipment, communication device, office equipment, industrial equipment etc.). The products mentioned herein shall not be intended for use for any "special application" (medical equipment whose purpose is to sustain life, aerospace instrument, nuclear control device, burning appliances, transportation machine, traffic signal system, safety equipment etc.) that shall require extremely high level of reliability and can directly threaten human lives in case of failure or malfunction of the product or may cause harm to human bodies, nor shall they grant any guarantee thereof. If you should intend to use our products for applications outside the standard applications of our customer who is considering such use and/or outside the scope of our intended standard applications, please consult with us prior to the intended use. If there is no consultation or inquiry before the intended use, our customer shall be solely responsible for the use.

■ Specifications of any and all SANYO Semiconductor Co.,Ltd. products described or contained herein stipulate the performance, characteristics, and functions of the described products in the independent state, and are not guarantees of the performance, characteristics, and functions of the described products as mounted in the customer's products or equipment. To verify symptoms and states that cannot be evaluated in an independent device, the customer should always evaluate and test devices mounted in the customer's products or equipment.

**SANYO Semiconductor Co., Ltd.**

TOKYO OFFICE Tokyo Bldg., 1-10, 1 Chome, Ueno, Taito-ku, TOKYO, 110-8534 JAPAN

# LA4537M

**Electrical Characteristics** at  $T_a = 25^\circ\text{C}$ ,  $R_L = 16\Omega$ ,  $R_g = 600\Omega$ , See specified Test Circuit.

Parameter	Symbol	Conditions	Ratings			Unit
			min	typ	max	
Quiescent current	$I_{CCO1}$	$V_{CC} = 1.2\text{V}$ , quiescent		3.5	6.0	mA
	$I_{CCO2}$	$V_{CC} = 2.5\text{V}$ , pin 10 $\rightarrow$ GND		1.4	2.5	mA
	$I_{CCO3}$	$V_{CC} = 2.5\text{V}$ , pin 1 $\rightarrow$ GND			1.0	$\mu\text{A}$
Voltage gain	VG	$V_{CC} = 1.2\text{V}$ , $f = 1\text{kHz}$ , $V_O = -20\text{dBm}$	28.5	30.0	31.5	dB
Voltage gain difference	$\Delta\text{VG}$	$V_{CC} = 1.2\text{V}$ , $f = 1\text{kHz}$ , $V_O = -20\text{dBm}$			1.0	dB
Total harmonic distortion	THD	$V_{CC} = 1.2\text{V}$ , $f = 1\text{kHz}$ , $P_O = 0.5\text{mW}$		0.5	1.5	%
Output power	$P_O$	$V_{CC} = 1.5\text{V}$ , $f = 1\text{kHz}$ , THD = 10%	5	8		mW
Crosstalk	CT	$V_{CC} = 1.2\text{V}$ , $f = 100\text{Hz}$ , $R_g = 1\text{k}\Omega$ , $V_O = -20\text{dB}$	40	45		dB
Ripple rejection	SVRR	$V_{CC} = 1.0\text{V}$ , $f = 100\text{Hz}$ , $R_g = 1\text{k}\Omega$ , $V_R = -30\text{dBm}$ , BPF = 100Hz	40	46		dB
Output noise voltage	$V_{NO}$	$V_{CC} = 2.5\text{V}$ , $R_g = 1\text{k}\Omega$ , BPF = 20Hz to 20kHz		55	80	$\mu\text{V}$
Power on current sensitivity	$I_1$ (on)	$V_{CC} = 0.85\text{V}$ , $V_5 \geq 0.5\text{V}$		0.1	1.0	$\mu\text{A}$
Power off voltage sensitivity	$V_1$ (off)	$V_{CC} = 0.85\text{V}$ , $V_5 \leq 0.1\text{V}$	0.5	0.6		V
Muting off current sensitivity	$I_{10}$ (off)	$V_{CC} = 0.85\text{V}$ , $V_5 \geq 0.5\text{V}$		0.1	1.0	$\mu\text{A}$
Muting on voltage sensitivity	$V_{10}$ (on)	$V_{CC} = 0.85\text{V}$ , $V_5 \leq 0.1\text{V}$	0.5	0.6		V

Note) The quiescent current is represented by the current flowing into pin 6. The respective maximum currents flowing into pin 1 and pin 10 are calculated by (pin voltage - 0.5) / 16 [V/k $\Omega$ ] and the total current increases by these current values.

## Package Dimensions

unit : mm (typ)

3086B

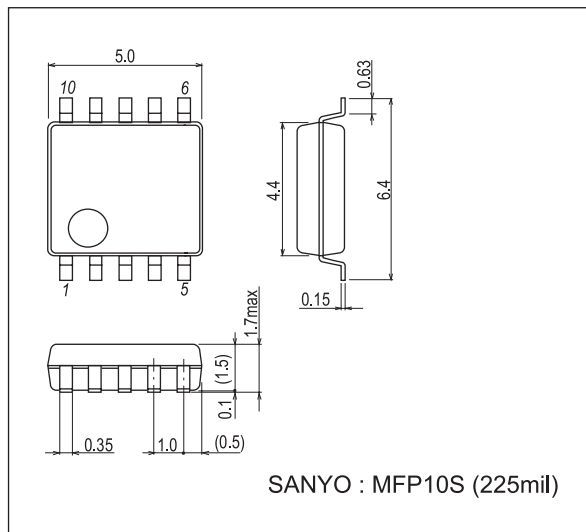

# LA4537M

## Block Diagram

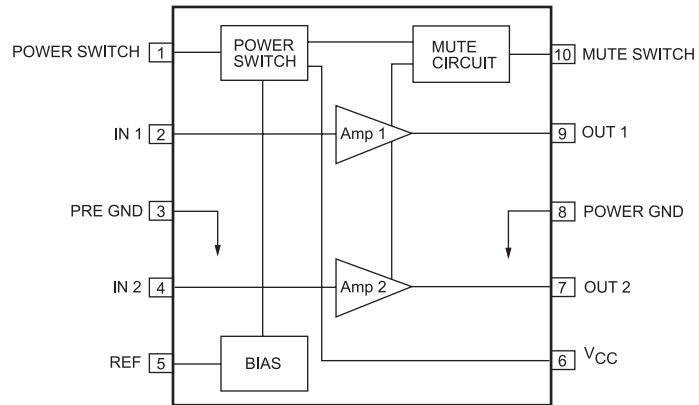

## Test Circuit

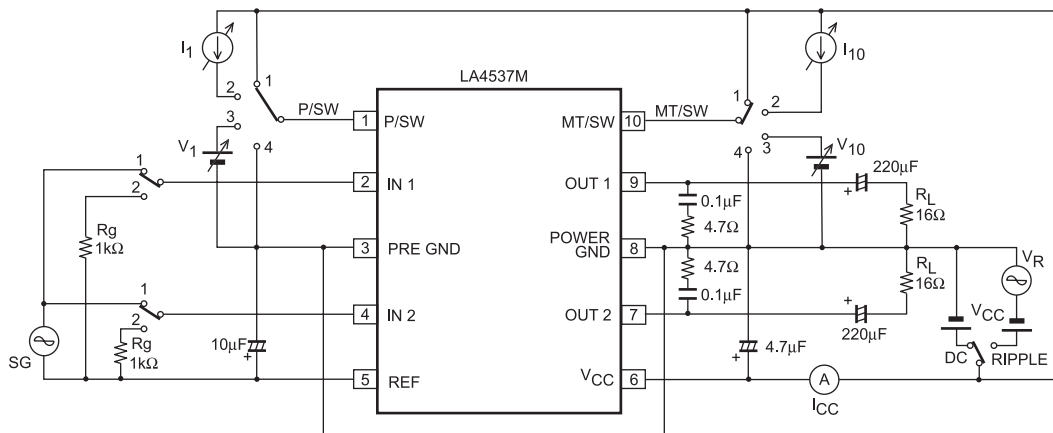



## Sample Application Circuit 1

(Standard)

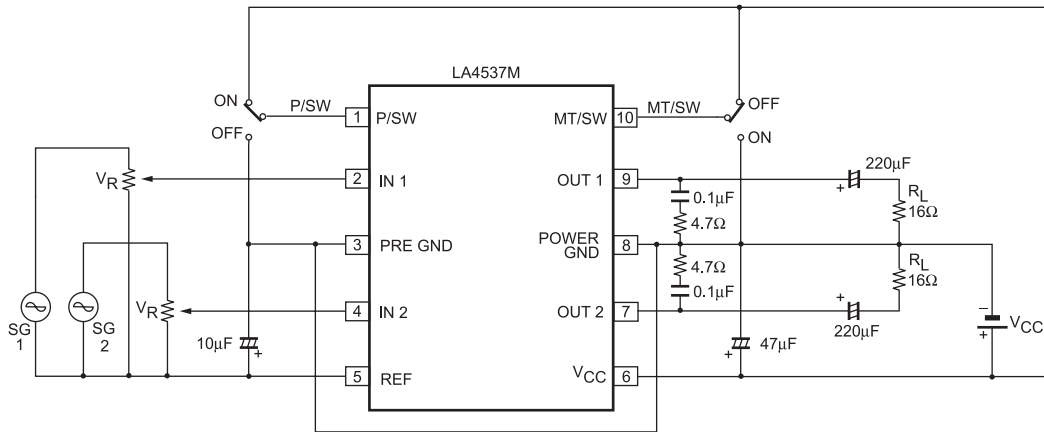

## Sample Application Circuit 2

(Output capacitor shared)

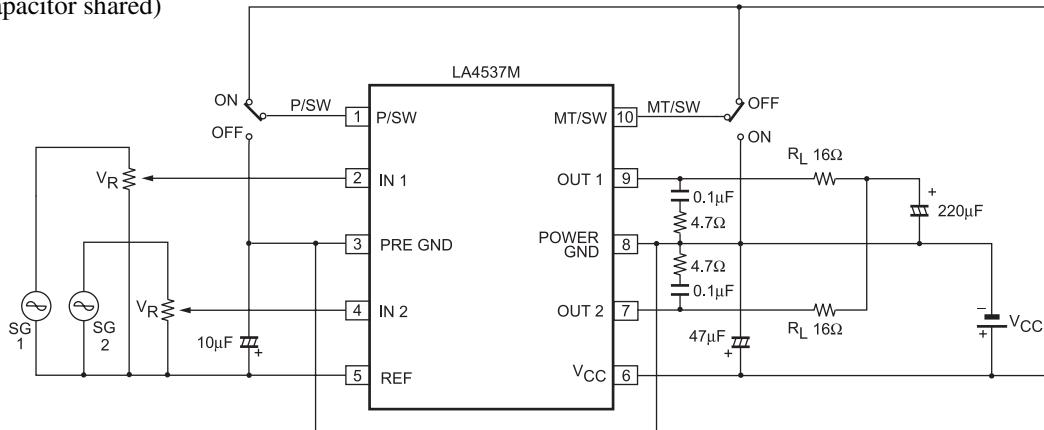

- SANYO Semiconductor Co.,Ltd. assumes no responsibility for equipment failures that result from using products at values that exceed, even momentarily, rated values (such as maximum ratings, operating condition ranges, or other parameters) listed in products specifications of any and all SANYO Semiconductor Co.,Ltd. products described or contained herein.
- SANYO Semiconductor Co.,Ltd. strives to supply high-quality high-reliability products, however, any and all semiconductor products fail or malfunction with some probability. It is possible that these probabilistic failures or malfunction could give rise to accidents or events that could endanger human lives, trouble that could give rise to smoke or fire, or accidents that could cause damage to other property. When designing equipment, adopt safety measures so that these kinds of accidents or events cannot occur. Such measures include but are not limited to protective circuits and error prevention circuits for safe design, redundant design, and structural design.
- In the event that any or all SANYO Semiconductor Co.,Ltd. products described or contained herein are controlled under any of applicable local export control laws and regulations, such products may require the export license from the authorities concerned in accordance with the above law.
- No part of this publication may be reproduced or transmitted in any form or by any means, electronic or mechanical, including photocopying and recording, or any information storage or retrieval system, or otherwise, without the prior written consent of SANYO Semiconductor Co.,Ltd.
- Any and all information described or contained herein are subject to change without notice due to product/technology improvement, etc. When designing equipment, refer to the "Delivery Specification" for the SANYO Semiconductor Co.,Ltd. product that you intend to use.
- Information (including circuit diagrams and circuit parameters) herein is for example only; it is not guaranteed for volume production.
- Upon using the technical information or products described herein, neither warranty nor license shall be granted with regard to intellectual property rights or any other rights of SANYO Semiconductor Co.,Ltd. or any third party. SANYO Semiconductor Co.,Ltd. shall not be liable for any claim or suits with regard to a third party's intellectual property rights which has resulted from the use of the technical information and products mentioned above.

This catalog provides information as of April, 2008. Specifications and information herein are subject to change without notice.