



Chipsmall Limited consists of a professional team with an average of over 10 year of expertise in the distribution of electronic components. Based in Hongkong, we have already established firm and mutual-benefit business relationships with customers from,Europe,America and south Asia,supplying obsolete and hard-to-find components to meet their specific needs.

With the principle of “Quality Parts,Customers Priority,Honest Operation,and Considerate Service”,our business mainly focus on the distribution of electronic components. Line cards we deal with include Microchip,ALPS,ROHM,Xilinx,Pulse,ON,Everlight and Freescale. Main products comprise IC,Modules,Potentiometer,IC Socket,Relay,Connector.Our parts cover such applications as commercial,industrial, and automotives areas.

We are looking forward to setting up business relationship with you and hope to provide you with the best service and solution. Let us make a better world for our industry!



Contact us

Tel: +86-755-8981 8866 Fax: +86-755-8427 6832

Email & Skype: info@chipsmall.com Web: www.chipsmall.com

Address: A1208, Overseas Decoration Building, #122 Zhenhua RD., Futian, Shenzhen, China





ON Semiconductor®

<http://onsemi.com>

LA5724MC

Monolithic Linear IC

Separately-Excited Step-Down Switching Regulator (Variable Type)

Overview

The LA5724MC is a separately-excited step-down switching regulator (variable type).

Functions

- Time-base generator (160kHz) incorporated.
- Current limiter incorporated.
- Thermal shutdown circuit incorporated.

Specifications

Absolute Maximum Ratings at $T_a = 25^\circ\text{C}$

Parameter	Symbol	Conditions	Ratings	Unit
Input voltage	V_{IN}		30	V
SW pin application reverse voltage	V_{SW}		-1	V
VOS pin application voltage	V_{VOS}		-0.2 to 7	V
Allowable power dissipation	$P_d \text{ max}$	Mounted on a circuit board.*	0.8	W
Operating temperature	T_{opr}		-30 to +125	$^\circ\text{C}$
Storage temperature	T_{stg}		-40 to +150	$^\circ\text{C}$
Junction temperature	$T_j \text{ max}$		150	$^\circ\text{C}$

* Specified circuit board : 114.3×76.1×1.6mm³, glass epoxy board.

Caution 1) Absolute maximum ratings represent the value which cannot be exceeded for any length of time.

Caution 2) Even when the device is used within the range of absolute maximum ratings, as a result of continuous usage under high temperature, high current, high voltage, or drastic temperature change, the reliability of the IC may be degraded. Please contact us for the further details.

Stresses exceeding Maximum Ratings may damage the device. Maximum Ratings are stress ratings only. Functional operation above the Recommended Operating Conditions is not implied. Extended exposure to stresses above the Recommended Operating Conditions may affect device reliability.

Recommended Operating Conditions at $T_a = 25^\circ\text{C}$

Parameter	Symbol	Conditions	Ratings	Unit
Input voltage range	V_{IN}		4.5 to 28	V

LA5724MC

Electrical Characteristics at $T_a = 25^\circ\text{C}$, $V_{IN} = 15\text{V}$

Parameter	Symbol	Conditions	Ratings			Unit
			min	typ	max	
Reference voltage	V_{OS}	$I_O = 0.3\text{A}$	1.20	1.23	1.26	V
Reference pin bias current	I_{FB}			1	2	μA
Switching frequency	fosc		128	160	192	kHz
Efficiency	η	$V_{OUT} = 5\text{V}$, $I_O = 0.3\text{A}$		82		%
Short-circuit protection circuit operating switching frequency	fscp			30		kHz
Saturation voltage	Vsat	$I_{OUT} = 0.3\text{A}$, $V_{OS} = 0\text{V}$		1.2		V
Maximum on duty	D max	$V_{OS} = 0\text{V}$		100		%
Minimum on duty	D min	$V_{OS} = 5\text{V}$		0		%
Output leakage current	I _{lk}	$SW_{OUT} = -1\text{V}$			200	μA
Supply current	I _{in}	$V_{OS} = 2\text{V}$		5	10	mA
Current limiter operating current	I _S		0.7			A
Thermal shutdown operating temperature	TSD	Designed target value. *		165		$^\circ\text{C}$
Thermal shutdown Hysteresis width	ΔTSD	Designed target value. *		15		$^\circ\text{C}$

* Design target value : No measurement made.

Package Dimensions

unit : mm (typ)

3424

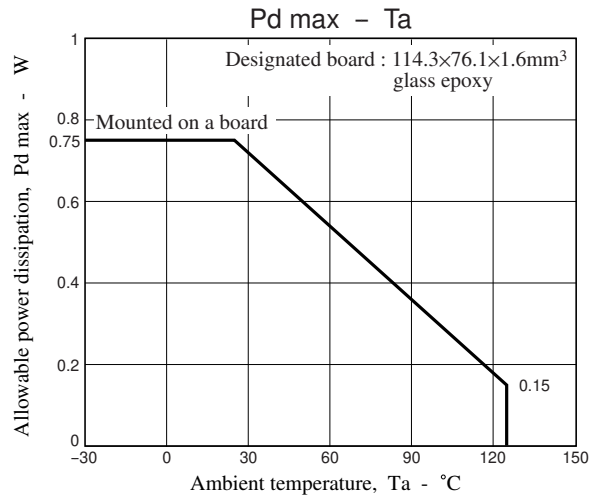
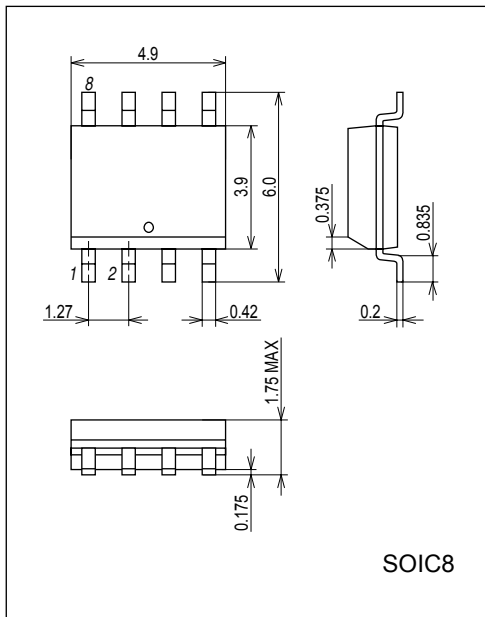

LA5724MC

Pin Assignment

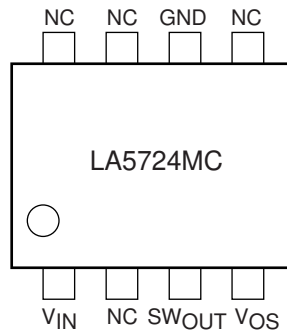

Block Diagram

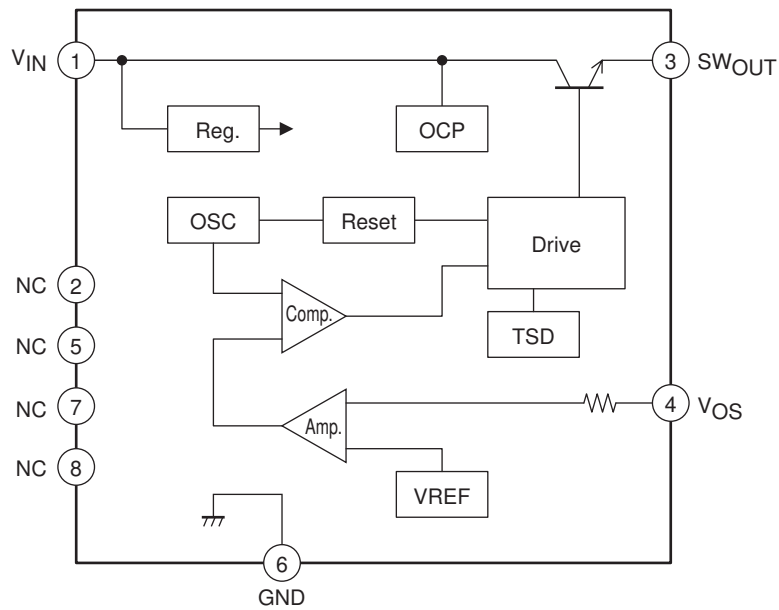

Note : Since the NC pins are not connected within the IC package, they can be used as connection points.

Application Circuit Example

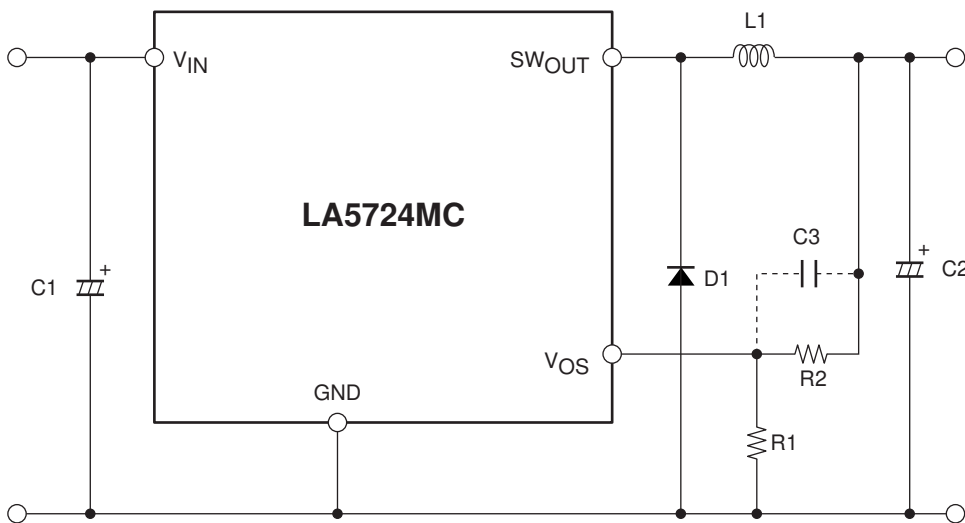

Note : In some cases, the output may not turn on if power is applied when a load is connected. If this is a problem, increase the value of the inductor.

Protection Circuit Functional Descriptions

Overcurrent protection function

The overcurrent protection function detects, on a pulse-by-pulse basis, the output transistor current and turns off that output transistor current if it exceeds 0.7A in a pulse-by-pulse manner.

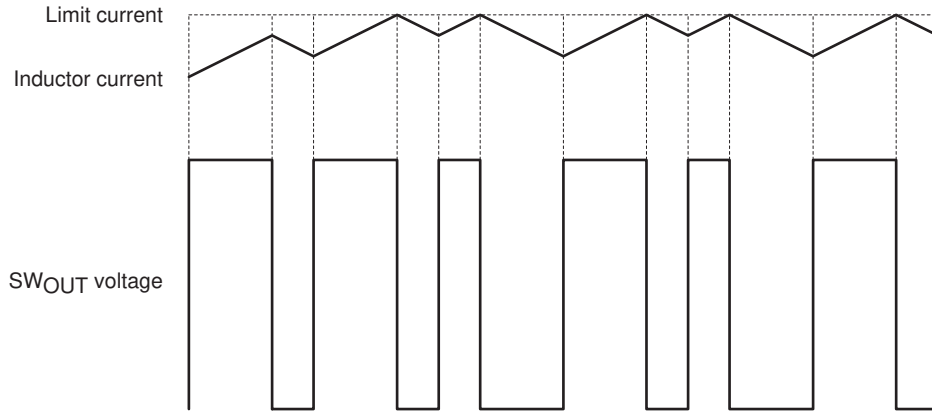

Short circuit protection function

This IC prevents the current from increasing when the outputs are shorted by setting the switching frequency to 30kHz if the V_{OS} pin voltage falls below 0.8V.

Note : At startup, since the switching frequency will be 30kHz while the V_{OS} pin voltage is 0.8V or lower, the current capacity is reduced. If the load is applied at startup and the applications has trouble starting, increase the value of the inductor to resolve this problem.

Timing Chart

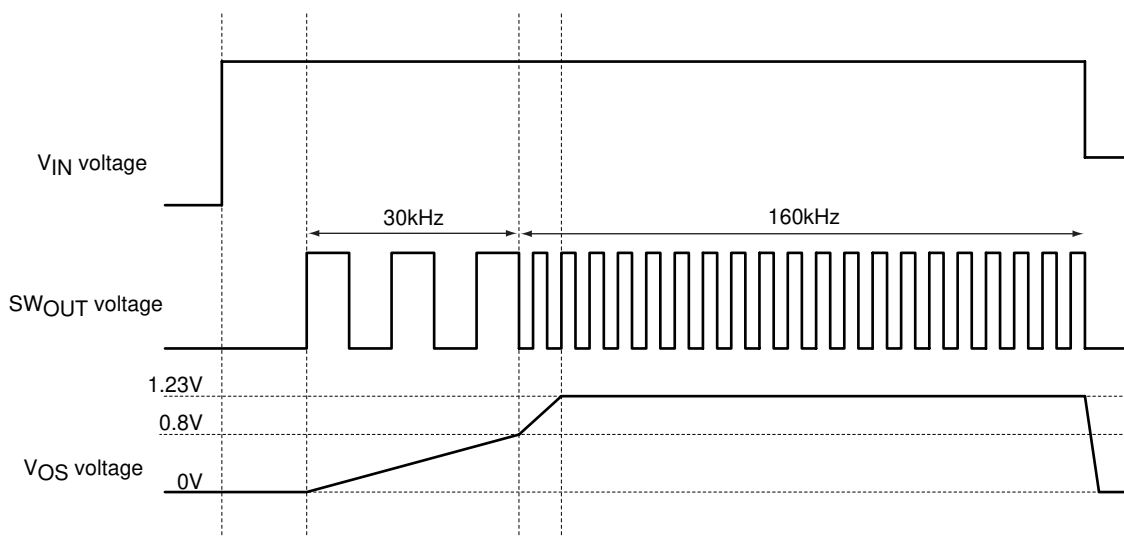

Part selection and set

1. Resistors R1 and R2

R1 and R2 are resistors to set the output voltage. When the large resistance value is set, the error of set voltage increases due to the VOS pin current. The output voltage may also increase due to the leak current of switching transistor at light load. In consequence, it is essential to set R1 and R2 currents to around 500µA.

$$R1 = \frac{1.23V}{500\mu A} \approx 2.4k\Omega \quad 2.0k\Omega \text{ to } 2.4k\Omega \text{ recommended}$$

$$R2 = \left(\frac{V_{OUT}}{1.23V} - 1\right) \times R1$$

The calculation equation gives the output voltage set by R1 and R2.

$$V_{OUT} = \left(1 + \frac{R2}{R1}\right) \times 1.23V(\text{typ})$$

2. Capacitor C1, C2 and C3

The large ripple current flows through C1 and C2, so that the high-frequency low-impedance product for switching power supply must be used. Do not use, for C2, a capacitor with extremely small equivalent series resistance (ESR), such as ceramic capacitor, tantalum capacitor. Otherwise, the output waveform may develop abnormal oscillation. The C2 capacitance and ESR value stabilization conditions are as follows:

$$\frac{1}{2 \times \pi \times C2 \times ESR} \leq 20kHz$$

C3 is a capacitor for phase compensation of the feedback loop. Abnormal oscillation may occur when the C2 capacitance value is small or the equivalent series resistance is small. In this case, addition of the capacitance of C3 enables phase compensation, contributing to stabilization of power supply.

3. Input capacitor: Effective-value current

The AC ripple current flowing in the input capacitor is larger than that in the output capacitor. The equation expressing the effective-value current is as follows. Use the capacitor within the rated current range.

$$I_{C1} = \sqrt{\frac{V_{out}}{V_{in}} \left(I_{out}^2 \left(1 - \frac{V_{out}}{V_{in}} \right) + \frac{1}{12} \times \Delta I_R^2 \right)} \quad [\text{Arms}]$$

4. Output capacitor: Effective-value current

The AC ripple current flowing in the capacitor is the triangular wave. Therefore, its effective value is obtained from the following equation. Select the output capacitor so that it does not exceed the allowable ripple current value.

$$I_{C2} = \frac{1}{\sqrt{3}} \times \frac{V_{OUT}(V_{IN}-V_{OUT})}{L \times f_{SW} \times V_{IN}} \quad [\text{Arms}]$$

f_{SW} = switching frequency ... 160kHz

5. Choke coil

Note that choke coil heating due to overload or load shorting may be a problem. The inductance value can be determined from the following equation once the input voltage, output voltage, and current ripple conditions are known. ΔI_R indicates the ripple current value.

Reference example: $V_{IN} = 12V$, $V_{OUT} = 5V$, $\Delta I_R = 150mA$

$$L = \frac{V_{IN} - V_{OUT} - V_{sat}}{\Delta I_R} \times T_{on}$$

$$= \frac{12 - 5.0 - 0.4}{0.15} \times 2.8 \times 10^{-6}$$

$$\approx 120\mu H$$

$$\left\{ \begin{array}{l} T_{on} = \frac{T}{(V_{IN} - V_{OUT} - V_{sat}) / (V_{OUT} + V_F) + 1} \\ T_{off} = T - T_{on} \\ T: \text{Switching repetition period} \quad \dots \quad 6.25\mu s \text{ is assumed for the calculation} \\ V_F: \text{Schottky diode forward voltage} \quad \dots \quad 0.4V \text{ is assumed for the calculation} \end{array} \right.$$

6. Inductance current: peak value

The ripple current peak value must be held within the rated current values for the inductor used. Here, IRP is the ripple current. IRP can be determined from the following equation.

$$\begin{aligned} \text{IRP} &= I_{\text{OUT}} + \frac{V_{\text{IN}} - V_{\text{OUT}} - V_{\text{sat}}}{2L} \times T_{\text{on}} \\ &= 0.5 + \frac{12 - 5.0 - 0.4}{2 \times 120 \times 10^{-6}} \times 2.8 \times 10^{-6} \\ &\approx 0.57\text{A} \end{aligned}$$

7. Inductance current: ripple current value

Here ΔI_R is the ripple current. ΔI_R can be determined from the following equation. If the load current becomes less than one half the ripple current, the inductor current will become discontinuous.

$$\begin{aligned} \Delta I_R &= \frac{V_{\text{IN}} - V_{\text{OUT}} - V_{\text{sat}}}{L} \times T_{\text{on}} \\ &= \frac{12 - 5.0 - 0.4}{120 \times 10^{-6}} \times 2.8 \times 10^{-6} \\ &\approx 0.15\text{A} \end{aligned}$$

8. Diode D1

A Schottky barrier diode must be used for the diode. If a fast recovery diode is used, it is possible that the IC could be destroyed by the applied reverse voltage due to the recovery and the on-state voltage.

9. Diode current: peak current

Applications must be designed so that the peak value of the diode current remains within the rated current of the diode. The peak value of the diode current will be the same current as the peak value of the inductor current.

10. Repetitive peak reverse voltage

Application must be designed so that the repetitive peak reverse voltage remains within the voltage rating of the diode. Here, VRRM is the repetitive peak reverse voltage. VRRM can be determined from the following equation.

$$V_{\text{RRM}} \geq V_{\text{CC}}$$

Since noise voltage and other terms will be added in actual in actual operation, the voltage handling capability of the device should be about 1.5 times that given by the above calculation.

ON Semiconductor and the ON logo are registered trademarks of Semiconductor Components Industries, LLC (SCILLC). SCILLC owns the rights to a number of patents, trademarks, copyrights, trade secrets, and other intellectual property. A listing of SCILLC's product/patent coverage may be accessed at www.onsemi.com/site/pdf/Patent-Marking.pdf. SCILLC reserves the right to make changes without further notice to any products herein. SCILLC makes no warranty, representation or guarantee regarding the suitability of its products for any particular purpose, nor does SCILLC assume any liability arising out of the application or use of any product or circuit, and specifically disclaims any and all liability, including without limitation special, consequential or incidental damages. "Typical" parameters which may be provided in SCILLC data sheets and/or specifications can and do vary in different applications and actual performance may vary over time. All operating parameters, including "Typicals" must be validated for each customer application by customer's technical experts. SCILLC does not convey any license under its patent rights nor the rights of others. SCILLC products are not designed, intended, or authorized for use as components in systems intended for surgical implant into the body, or other applications intended to support or sustain life, or for any other application in which the failure of the SCILLC product could create a situation where personal injury or death may occur. Should Buyer purchase or use SCILLC products for any such unintended or unauthorized application, Buyer shall indemnify and hold SCILLC and its officers, employees, subsidiaries, affiliates, and distributors harmless against all claims, costs, damages, and expenses, and reasonable attorney fees arising out of, directly or indirectly, any claim of personal injury or death associated with such unintended or unauthorized use, even if such claim alleges that SCILLC was negligent regarding the design or manufacture of the part. SCILLC is an Equal Opportunity/Affirmative Action Employer. This literature is subject to all applicable copyright laws and is not for resale in any manner.