



Chipsmall Limited consists of a professional team with an average of over 10 year of expertise in the distribution of electronic components. Based in Hongkong, we have already established firm and mutual-benefit business relationships with customers from,Europe,America and south Asia,supplying obsolete and hard-to-find components to meet their specific needs.

With the principle of “Quality Parts,Customers Priority,Honest Operation,and Considerate Service”,our business mainly focus on the distribution of electronic components. Line cards we deal with include Microchip,ALPS,ROHM,Xilinx,Pulse,ON,Everlight and Freescale. Main products comprise IC,Modules,Potentiometer,IC Socket,Relay,Connector.Our parts cover such applications as commercial,industrial, and automotives areas.

We are looking forward to setting up business relationship with you and hope to provide you with the best service and solution. Let us make a better world for our industry!



## Contact us

Tel: +86-755-8981 8866 Fax: +86-755-8427 6832

Email & Skype: info@chipsmall.com Web: www.chipsmall.com

Address: A1208, Overseas Decoration Building, #122 Zhenhua RD., Futian, Shenzhen, China



## LAN8740A/LAN8740Ai



# Small Footprint MII/RMII 10/100 Energy Efficient Ethernet Transceiver with HP Auto-MDIX and flexPWR<sup>®</sup> Technology

## PRODUCT FEATURES

Datasheet

### Highlights

- Single-Chip Ethernet Physical Layer Transceiver (PHY)
- Compliant with Energy Efficient Ethernet 802.3az
- Cable diagnostic support
- Wake on LAN (WoL) support
- Comprehensive flexPWR<sup>®</sup> technology
  - Flexible power management architecture
  - LVCMOS Variable I/O voltage range: +1.8 V to +3.3 V
  - Integrated 1.2 V regulator with disable feature
- HP Auto-MDIX support
- Small footprint 32-pin SQFN lead-free RoHS compliant package (5 x 5 x 0.9 mm height)
- Deterministic 100 Mb internal loopback latency (MII Mode)

### Target Applications

- Set-Top Boxes
- Networked Printers and Servers
- Test Instrumentation
- LAN on Motherboard
- Embedded Telecom Applications
- Video Record/Playback Systems
- Cable Modems/Routers
- DSL Modems/Routers
- Digital Video Recorders
- IP and Video Phones
- Wireless Access Points
- Digital Televisions
- Digital Media Adaptors/Servers
- Gaming Consoles
- POE Applications (Refer to SMSC Application Note 17.18)

### Key Benefits

- High-performance 10/100 Ethernet transceiver
  - Compliant with IEEE802.3/802.3u (Fast Ethernet)
  - Compliant with ISO 802-3/IEEE 802.3 (10BASE-T)
  - Compliant with Energy Efficient Ethernet IEEE 802.3az
  - Loop-back modes
  - Auto-negotiation
  - Automatic polarity detection and correction
  - Link status change wake-up detection
  - Vendor specific register functions
  - Supports both MII and the reduced pin count RMII interfaces
- Power and I/Os
  - Various low power modes
  - Integrated power-on reset circuit
  - Two status LED outputs
  - May be used with a single 3.3 V supply
- Additional Features
  - Ability to use a low cost 25 MHz crystal for reduced BOM
- Packaging
  - 32-pin SQFN (5 x 5 mm) lead-free RoHS compliant package with MII and RMII
- Environmental
  - Commercial temperature range (0°C to +70°C)
  - Industrial temperature range (-40°C to +85°C)

Datasheet

**ORDER NUMBER(S):**

**LAN8740A-EN (Tray) for 32-pin, SQFN lead-free RoHS compliant package (0°C to +70°C temp)**  
**LAN8740Ai-EN (Tray) for 32-pin, SQFN lead-free RoHS compliant package (-40°C to +85°C temp)**  
**LAN8740A-EN-TR (Tape & Reel) for 32-pin, SQFN lead-free RoHS compliant package (0°C to +70°C temp)**  
**LAN8740Ai-EN-TR (Tape & Reel) for 32-pin, SQFN lead-free RoHS compliant package (-40 to +85°C temp)**

**This product meets the halogen maximum concentration values per IEC61249-2-21**  
**For RoHS compliance and environmental information, please visit [www.smsc.com/rohs](http://www.smsc.com/rohs)**

*Please contact your SMSC sales representative for additional documentation related to this product such as application notes, anomaly sheets, and design guidelines.*

Copyright © 2013 SMSC or its subsidiaries. All rights reserved.

Circuit diagrams and other information relating to SMSC products are included as a means of illustrating typical applications. Consequently, complete information sufficient for construction purposes is not necessarily given. Although the information has been checked and is believed to be accurate, no responsibility is assumed for inaccuracies. SMSC reserves the right to make changes to specifications and product descriptions at any time without notice. Contact your local SMSC sales office to obtain the latest specifications before placing your product order. The provision of this information does not convey to the purchaser of the described semiconductor devices any licenses under any patent rights or other intellectual property rights of SMSC or others. All sales are expressly conditional on your agreement to the terms and conditions of the most recently dated version of SMSC's standard Terms of Sale Agreement dated before the date of your order (the "Terms of Sale Agreement"). The product may contain design defects or errors known as anomalies which may cause the product's functions to deviate from published specifications. Anomaly sheets are available upon request. SMSC products are not designed, intended, authorized or warranted for use in any life support or other application where product failure could cause or contribute to personal injury or severe property damage. Any and all such uses without prior written approval of an Officer of SMSC and further testing and/or modification will be fully at the risk of the customer. Copies of this document or other SMSC literature, as well as the Terms of Sale Agreement, may be obtained by visiting SMSC's website at <http://www.smsc.com>. SMSC is a registered trademark of Standard Microsystems Corporation ("SMSC"). Product names and company names are the trademarks of their respective holders.

The Microchip name and logo, and the Microchip logo are registered trademarks of Microchip Technology Incorporated in the U.S.A. and other countries.

**SMSC DISCLAIMS AND EXCLUDES ANY AND ALL WARRANTIES, INCLUDING WITHOUT LIMITATION ANY AND ALL IMPLIED WARRANTIES OF MERCHANTABILITY, FITNESS FOR A PARTICULAR PURPOSE, TITLE, AND AGAINST INFRINGEMENT AND THE LIKE, AND ANY AND ALL WARRANTIES ARISING FROM ANY COURSE OF DEALING OR USAGE OF TRADE. IN NO EVENT SHALL SMSC BE LIABLE FOR ANY DIRECT, INCIDENTAL, INDIRECT, SPECIAL, PUNITIVE, OR CONSEQUENTIAL DAMAGES; OR FOR LOST DATA, PROFITS, SAVINGS OR REVENUES OF ANY KIND; REGARDLESS OF THE FORM OF ACTION, WHETHER BASED ON CONTRACT; TORT; NEGLIGENCE OF SMSC OR OTHERS; STRICT LIABILITY; BREACH OF WARRANTY; OR OTHERWISE; WHETHER OR NOT ANY REMEDY OF BUYER IS HELD TO HAVE FAILED OF ITS ESSENTIAL PURPOSE, AND WHETHER OR NOT SMSC HAS BEEN ADVISED OF THE POSSIBILITY OF SUCH DAMAGES.**



## Table of Contents

<b>Chapter 1 Introduction</b>	<b>8</b>
1.1 General Terms and Conventions	8
1.2 General Description	8
<b>Chapter 2 Pin Description and Configuration</b>	<b>10</b>
2.1 Pin Assignments	19
2.2 Buffer Types	20
<b>Chapter 3 Functional Description</b>	<b>21</b>
3.1 Transceiver	21
3.1.1 100BASE-TX Transmit	21
3.1.2 100BASE-TX Receive	24
3.1.3 10BASE-T Transmit	27
3.1.4 10BASE-T Receive	27
3.2 Auto-Negotiation	28
3.2.1 Parallel Detection	30
3.2.2 Restarting Auto-Negotiation	30
3.2.3 Disabling Auto-Negotiation	30
3.2.4 Half vs. Full Duplex	30
3.3 HP Auto-MDIX Support	31
3.4 MAC Interface	31
3.4.1 MII	32
3.4.2 RMII	32
3.4.3 MII vs. RMII Configuration	34
3.5 Serial Management Interface (SMI)	35
3.6 Interrupt Management	36
3.6.1 Primary Interrupt System	37
3.6.2 Alternate Interrupt System	38
3.7 Configuration Straps	39
3.7.1 PHYAD[2:0]: PHY Address Configuration	39
3.7.2 MODE[2:0]: Mode Configuration	40
3.7.3 RMIISEL: MII/RMII Mode Configuration	41
3.7.4 REGOFF: Internal +1.2 V Regulator Configuration	41
3.7.5 nINTSEL: nINT/TXER/TXD4 Configuration	42
3.8 Miscellaneous Functions	43
3.8.1 LEDs	43
3.8.2 Variable Voltage I/O	47
3.8.3 Power-Down Modes	47
3.8.4 Wake on LAN (WoL)	48
3.8.5 Energy Efficient Ethernet	54
3.8.6 Isolate Mode	54
3.8.7 Resets	54
3.8.8 Carrier Sense	55
3.8.9 Collision Detect	55
3.8.10 Link Integrity Test	55
3.8.11 Cable Diagnostics	56
3.8.12 Loopback Operation	61
3.9 Application Diagrams	63

**Datasheet**

3.9.1	Simplified System Level Application Diagram	63
3.9.2	Power Supply Diagram (1.2 V Supplied by Internal Regulator)	64
3.9.3	Power Supply Diagram (1.2 V Supplied by External Source)	65
3.9.4	Twisted-Pair Interface Diagram (Single Power Supply)	66
3.9.5	Twisted-Pair Interface Diagram (Dual Power Supplies)	67
<hr/>		
<b>Chapter 4</b>	<b>Register Descriptions</b>	<b>68</b>
4.1	Register Nomenclature	68
4.2	Control and Status Registers	69
4.2.1	Basic Control Register	70
4.2.2	Basic Status Register	71
4.2.3	PHY Identifier 1 Register	73
4.2.4	PHY Identifier 2 Register	74
4.2.5	Auto Negotiation Advertisement Register	75
4.2.6	Auto Negotiation Link Partner Ability Register	76
4.2.7	Auto Negotiation Expansion Register	77
4.2.8	Auto Negotiation Next Page TX Register	78
4.2.9	Auto Negotiation Next Page RX Register	79
4.2.10	MMD Access Control Register	80
4.2.11	MMD Access Address/Data Register	81
4.2.12	EDPD NLP / Crossover Time / EEE Configuration Register	82
4.2.13	Mode Control/Status Register	83
4.2.14	Special Modes Register	84
4.2.15	TDR Patterns/Delay Control Register	85
4.2.16	TDR Control/Status Register	86
4.2.17	Symbol Error Counter Register	87
4.2.18	Special Control/Status Indications Register	88
4.2.19	Cable Length Register	89
4.2.20	Interrupt Source Flag Register	90
4.2.21	Interrupt Mask Register	91
4.2.22	PHY Special Control/Status Register	92
4.3	MDIO Manageable Device (MMD) Registers	93
4.3.1	PCS Control 1 Register	95
4.3.2	PCS Status 1 Register	96
4.3.3	PCS MMD Devices Present 1 Register	97
4.3.4	PCS MMD Devices Present 2 Register	98
4.3.5	EEE Capability Register	99
4.3.6	EEE Wake Error Register	100
4.3.7	Wakeup Control and Status Register (WUCSR)	101
4.3.8	Wakeup Filter Configuration Register A (WUF_CFGA)	103
4.3.9	Wakeup Filter Configuration Register B (WUF_CFGB)	104
4.3.10	Wakeup Filter Byte Mask Registers (WUF_MASK)	105
4.3.11	MAC Receive Address A Register (RX_ADDRA)	107
4.3.12	MAC Receive Address B Register (RX_ADDRB)	108
4.3.13	MAC Receive Address C Register (RX_ADDR_C)	109
4.3.14	Miscellaneous Configuration Register (MCFGR)	110
4.3.15	Auto-Negotiation MMD Devices Present 1 Register	111
4.3.16	Auto-Negotiation MMD Devices Present 2 Register	112
4.3.17	EEE Advertisement Register	113
4.3.18	EEE Link Partner Advertisement Register	114
4.3.19	Vendor Specific MMD 1 Device ID 1 Register	115
4.3.20	Vendor Specific MMD 1 Device ID 2 Register	116

4.3.21	Vendor Specific 1 MMD Devices Present 1 Register	117
4.3.22	Vendor Specific 1 MMD Devices Present 2 Register	118
4.3.23	Vendor Specific MMD 1 Status Register	119
4.3.24	TDR Match Threshold Register	120
4.3.25	TDR Short/Open Threshold Register	121
4.3.26	Vendor Specific MMD 1 package ID 1 Register	122
4.3.27	Vendor Specific MMD 1 package ID 2 Register	123
<hr/>		
<b>Chapter 5</b>	<b>Operational Characteristics</b>	<b>124</b>
5.1	Absolute Maximum Ratings*	124
5.2	Operating Conditions**	125
5.3	Package Thermal Specifications	125
5.4	Power Consumption	126
5.4.1	Regulator Disabled	126
5.4.2	Regulator Enabled	126
5.5	DC Specifications	127
5.6	AC Specifications	129
5.6.1	Equivalent Test Load	129
5.6.2	Power-On nRST & Configuration Strap Timing	130
5.6.3	MII Interface Timing	131
5.6.4	RMII Interface Timing	134
5.6.5	SMI Timing	136
5.7	Clock Circuit	137
<hr/>		
<b>Chapter 6</b>	<b>Package Outline</b>	<b>138</b>
<hr/>		
<b>Chapter 7</b>	<b>Revision History</b>	<b>141</b>

Datasheet

## List of Figures

Figure 1.1	System Block Diagram	9
Figure 1.2	Architectural Overview	9
Figure 2.1	32-SQFN Pin Assignments (TOP VIEW)	10
Figure 3.1	100BASE-TX Transmit Data Path	21
Figure 3.2	100BASE-TX Receive Data Path	24
Figure 3.3	Relationship Between Received Data and Specific MII Signals	26
Figure 3.4	Direct Cable Connection vs. Cross-over Cable Connection	31
Figure 3.5	MDIO Timing and Frame Structure - READ Cycle	35
Figure 3.6	MDIO Timing and Frame Structure - WRITE Cycle	35
Figure 3.7	LED1/nINT/nPME/REGOFF with Internal Regulator Disabled	43
Figure 3.8	LED1/nINT/nPME/REGOFF with Internal Regulator Enabled	44
Figure 3.9	LED2/nINT/nPME with nINTSEL Enabled	45
Figure 3.10	LED2/nINT/nPME with nINTSEL Disabled	45
Figure 3.11	LED1/REGOFF Polarity Configuration	46
Figure 3.12	LED2/nINTSEL Polarity Configuration	47
Figure 3.13	TDR Usage Flow Diagram	57
Figure 3.14	Near-end Loopback Block Diagram	61
Figure 3.15	Far Loopback Block Diagram	61
Figure 3.16	Connector Loopback Block Diagram	62
Figure 3.17	Simplified System Level Application Diagram	63
Figure 3.18	Power Supply Diagram (1.2 V Supplied by Internal Regulator)	64
Figure 3.19	Power Supply Diagram (1.2 V Supplied by External Source)	65
Figure 3.20	Twisted-Pair Interface Diagram (Single Power Supply)	66
Figure 3.21	Twisted-Pair Interface Diagram (Dual Power Supplies)	67
Figure 5.1	Output Equivalent Test Load	129
Figure 5.2	Power-On nRST & Configuration Strap Timing	130
Figure 5.3	MII Receive Timing	131
Figure 5.4	MII Transmit Timing	132
Figure 5.5	100 Mbps Internal Loopback MII Timing	133
Figure 5.6	RMII Timing	134
Figure 5.7	SMI Timing	136
Figure 6.1	32-SQFN Package	138
Figure 6.2	Recommended PCB Land Pattern	139
Figure 6.3	Taping Dimensions and Part Orientation	139
Figure 6.4	Reel Dimensions	140
Figure 6.5	Tape Length and Part Quantity	140

## List of Tables

Table 2.1	MII/RMII Signals	11
Table 2.2	LED Pins	15
Table 2.3	Serial Management Interface (SMI) Pins	17
Table 2.4	Ethernet Pins	17
Table 2.5	Miscellaneous Pins	17
Table 2.6	Analog Reference Pins	18
Table 2.7	Power Pins	18
Table 2.8	32-SQFN Package Pin Assignments	19
Table 2.9	Buffer Types	20
Table 3.1	4B/5B Code Table	22
Table 3.2	MII/RMII Signal Mapping	34
Table 3.3	Interrupt Management Table	37
Table 3.4	Alternative Interrupt System Management Table	38
Table 3.5	Pin Names for Address Bits	39
Table 3.6	MODE[2:0] Bus	40
Table 3.7	Pin Names for Mode Bits	40
Table 3.8	Wakeup Generation Cases	52
Table 3.9	TDR Propagation Constants	58
Table 3.10	Typical Measurement Error for Open Cable (+/- Meters)	59
Table 3.11	Typical Measurement Error for Shorted Cable (+/- Meters)	59
Table 3.12	Match Case Estimated Cable Length (CBLN) Lookup Table	60
Table 4.1	Register Bit Types	68
Table 4.2	SMI Register Map	69
Table 4.3	MMD Registers	93
Table 5.1	Package Thermal Parameters	125
Table 5.2	Current Consumption and Power Dissipation (Reg. Disabled)	126
Table 5.3	Current Consumption and Power Dissipation (Reg. Enabled)	126
Table 5.4	Non-Variable I/O Buffer Characteristics	127
Table 5.5	Variable I/O Buffer Characteristics	128
Table 5.6	100BASE-TX Transceiver Characteristics	128
Table 5.7	10BASE-T Transceiver Characteristics	129
Table 5.8	Power-On nRST & Configuration Strap Timing Values	130
Table 5.9	MII Receive Timing Values	131
Table 5.10	MII Transmit Timing Values	132
Table 5.11	100 Mbps Internal Loopback MII Timing Values	133
Table 5.12	RMII Timing Values	135
Table 5.13	RMII CLKIN (REF_CLK) Timing Values	135
Table 5.14	SMI Timing Values	136
Table 5.15	Crystal Specifications	137
Table 6.1	32-SQFN Dimensions	138
Table 7.1	Customer Revision History	141



## Chapter 1 Introduction

### 1.1 General Terms and Conventions

The following is a list of the general terms used throughout this document:

<b>BYTE</b>	8 bits
<b>FIFO</b>	First In First Out buffer; often used for elasticity buffer
<b>MAC</b>	Media Access Controller
<b>MII</b>	Media Independent Interface
<b>RMII™</b>	Reduced Media Independent Interface
<b>N/A</b>	Not Applicable
<b>X</b>	Indicates that a logic state is “don’t care” or undefined.
<b>RESERVED</b>	Refers to a reserved bit field or address. Unless otherwise noted, reserved bits must always be zero for write operations. Unless otherwise noted, values are not guaranteed when reading reserved bits. Unless otherwise noted, do not read or write to reserved addresses.
<b>SMI</b>	Serial Management Interface

### 1.2 General Description

The LAN8740A/LAN8740Ai is a low-power 10BASE-T/100BASE-TX physical layer (PHY) transceiver with variable I/O voltage that is compliant with the IEEE 802.3, 802.3u, and 802.3az (Energy Efficient Ethernet) standards. Energy Efficient Ethernet (EEE) support results in significant power savings during low link utilizations.

The LAN8740A/LAN8740Ai supports communication with an Ethernet MAC via a standard MII (IEEE 802.3u)/RMII interface. It contains a full-duplex 10-BASE-T/100BASE-TX transceiver and supports 10 Mbps (10BASE-T) and 100 Mbps (100BASE-TX) operation. The LAN8740A/LAN8740Ai implements auto-negotiation to automatically determine the best possible speed and duplex mode of operation. HP Auto-MDIX support allows the use of direct connect or cross-over LAN cables. Integrated Wake on LAN (WoL) support provides a mechanism to trigger an interrupt upon reception of a perfect DA, broadcast, magic packet, or wakeup frame.

The LAN8740A/LAN8740Ai supports both IEEE 802.3-2005 compliant and vendor-specific register functions. However, no register access is required for operation. The initial configuration may be selected via the configuration pins as described in [Section 3.7, "Configuration Straps," on page 39](#). Register-selectable configuration options may be used to further define the functionality of the transceiver.

The LAN8740A/LAN8740Ai can be programmed to support wake-on-LAN at the physical layer, allowing detection of configurable Wake-up Frame and Magic packets. This feature allows filtering of packets at the PHY layer, without requiring MAC intervention. Additionally, the LAN8740A/LAN8740Ai supports cable diagnostics which allow the device to identify opens/shorts and their location on the cable via vendor-specific registers.

Per IEEE 802.3-2005 standards, all digital interface pins are tolerant to 3.6 V. The device can be configured to operate on a single 3.3 V supply utilizing an integrated 3.3 V to 1.2 V linear regulator.

The linear regulator may be optionally disabled, allowing usage of a high efficiency external regulator for lower system power dissipation.

The LAN8740A/LAN8740Ai is available in commercial (0°C to +70°C) and industrial (-40°C to +85°C) temperature range versions. A typical system application is shown in Figure 1.1. Figure 1.2 provides an internal block diagram of the device.

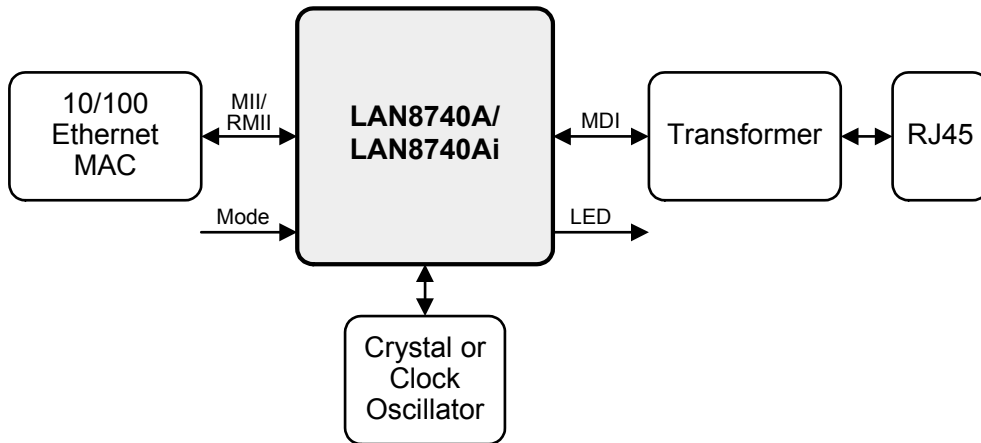

Figure 1.1 System Block Diagram

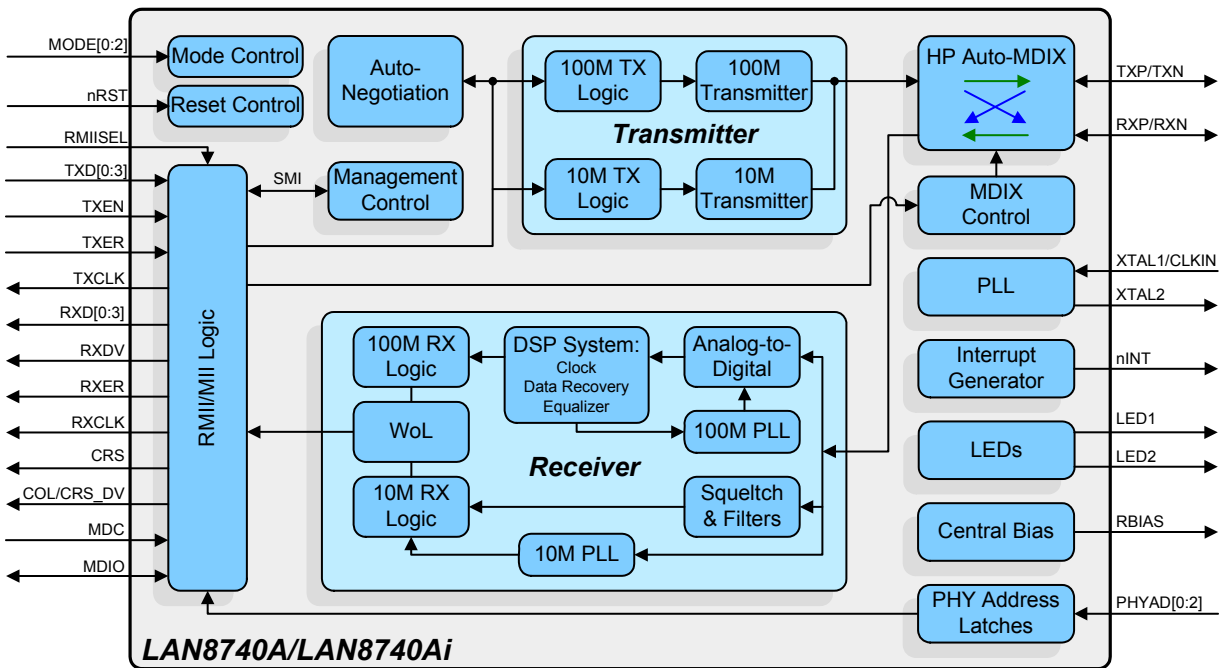
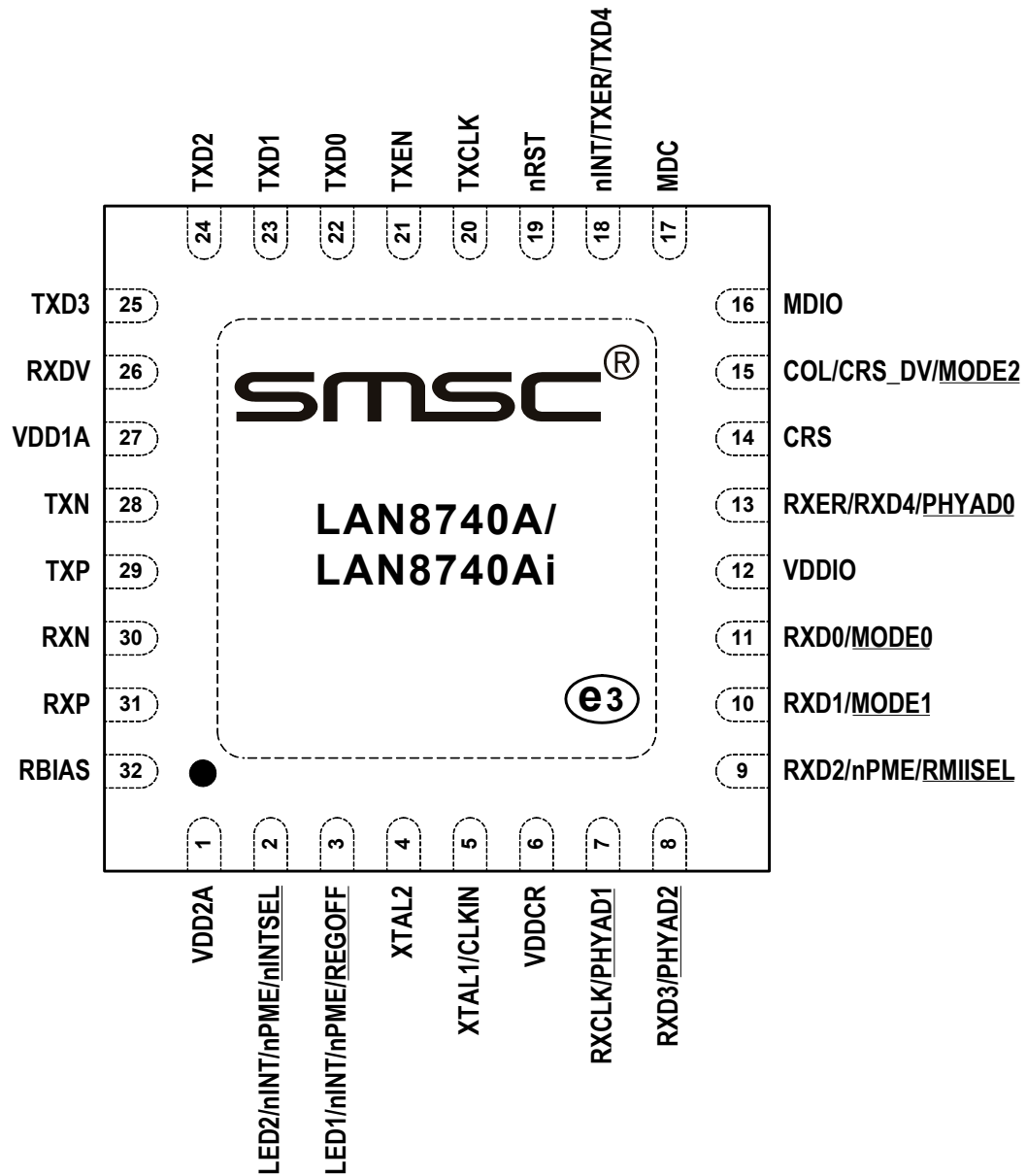

Figure 1.2 Architectural Overview

## Chapter 2 Pin Description and Configuration



**Note:** Exposed pad (VSS) on bottom of package must be connected to ground.

Figure 2.1 32-SQFN Pin Assignments (TOP VIEW)

**Note:** When a lower case “n” is used at the beginning of the signal name, it indicates that the signal is active low. For example, nRST indicates that the reset signal is active low.

**Note:** The buffer type for each signal is indicated in the BUFFER TYPE column. A description of the buffer types is provided in [Section 2.2](#).

Table 2.1 MII/RMII Signals

NUM PINS	NAME	SYMBOL	BUFFER TYPE	DESCRIPTION
1	Transmit Data 0	TXD0	VIS	The MAC transmits data to the transceiver using this signal in all modes.
1	Transmit Data 1	TXD1	VIS	The MAC transmits data to the transceiver using this signal in all modes.
1	Transmit Data 2 (MII Mode)	TXD2	VIS	The MAC transmits data to the transceiver using this signal in MII mode. <b>Note:</b> This signal must be grounded in RMII mode.
1	Transmit Data 3 (MII Mode)	TXD3	VIS	The MAC transmits data to the transceiver using this signal in MII mode. <b>Note:</b> This signal must be grounded in RMII mode.
1	Interrupt Output	nINT	VOD8 (PU)	Active low interrupt output. Place an external resistor pull-up to VDDIO. <b>Note:</b> The nINT signal can be optionally configured to output on the LED1 or LED2 pins. Refer to <a href="#">Section 3.6, "Interrupt Management,"</a> on page 36 for additional details on device interrupts. <b>Note:</b> Refer to <a href="#">Section 3.8.1.6, "nINTSEL and LED2 Polarity Selection,"</a> on page 47 for details on how the <u>nINTSEL</u> configuration strap is used to determine the function of this pin.
	Transmit Error (MII Mode)	TXER	VIS	When driven high, the 4B/5B encode process substitutes the Transmit Error code-group (/H/) for the encoded data word. This input is ignored in the 10BASE-T mode of operation. This signal is also used in EEE mode as TXER when TXEN = 1, and as LPI when TXEN = 0. <b>Note:</b> This signal is not used in RMII mode.
	Transmit Data 4 (MII Mode)	TXD4	VIS (PU)	In Symbol Interface (5B decoding) mode, this signal becomes the MII Transmit Data 4 line (the MSB of the 5-bit symbol code-group). <b>Note:</b> This signal is not used in RMII mode.
1	Transmit Enable	TXEN	VIS (PD)	Indicates that valid transmission data is present on TXD[3:0]. In RMII mode, only TXD[1:0] provide valid data.
1	Transmit Clock (MII Mode)	TXCLK	VO8	Used to latch data from the MAC into the transceiver. <ul style="list-style-type: none"> <li>■ MII (100BASE-TX): 25 MHz</li> <li>■ MII (10BASE-T): 2.5 MHz</li> </ul> <b>Note:</b> This signal is not used in RMII mode.

## Datasheet

Table 2.1 MII/RMII Signals (continued)

NUM PINS	NAME	SYMBOL	BUFFER TYPE	DESCRIPTION
1	Receive Data 0	RXD0	VO8	Bit 0 of the 4 (2 in RMII mode) data bits that are sent by the transceiver on the receive path.
	PHY Operating Mode 0 Configuration Strap	<u>MODE0</u>	VIS (PU)	Combined with MODE1 and MODE2, this configuration strap sets the default PHY mode.  See <a href="#">Note 2.1</a> for more information on configuration straps. <b>Note:</b> Refer to <a href="#">Section 3.7.2, "MODE[2:0]: Mode Configuration,"</a> on page 40 for additional details.
1	Receive Data 1	RXD1	VO8	Bit 1 of the 4 (2 in RMII mode) data bits that are sent by the transceiver on the receive path.
	PHY Operating Mode 1 Configuration Strap	<u>MODE1</u>	VIS (PU)	Combined with MODE0 and MODE2, this configuration strap sets the default PHY mode.  See <a href="#">Note 2.1</a> for more information on configuration straps. <b>Note:</b> Refer to <a href="#">Section 3.7.2, "MODE[2:0]: Mode Configuration,"</a> on page 40 for additional details.
1	Receive Data 2 (MII Mode)	RXD2	VO8	Bit 2 of the 4 (in MII mode) data bits that are sent by the transceiver on the receive path. <b>Note:</b> This signal is not used in RMII mode.
	Power Management Event Output	nPME	VO8	When in RMII mode, this pin may be used alternatively as an active low Power Management Event (PME) output. <b>Note:</b> The nPME signal can be optionally configured to output on the LED1, LED2, or RXD2/nPME/nINTSEL pins. Refer to <a href="#">Section 3.8.4, "Wake on LAN (WoL),"</a> on page 48 for additional nPME and WoL information.
	MI/RMII Mode Select Configuration Strap	<u>RMIISEL</u>	VIS (PD)	This configuration strap selects the MII or RMII mode of operation. When strapped low to VSS, MII mode is selected. When strapped high to VDDIO RMII mode is selected.  See <a href="#">Note 2.1</a> for more information on configuration straps. <b>Note:</b> Refer to <a href="#">Section 3.7.3, "RMIISEL: MII/RMII Mode Configuration,"</a> on page 41 for additional details.



Table 2.1 MII/RMII Signals (continued)

NUM PINS	NAME	SYMBOL	BUFFER TYPE	DESCRIPTION
1	Receive Data 3 (MII Mode)	RXD3	VO8	Bit 3 of the 4 (in MII mode) data bits that are sent by the transceiver on the receive path. <b>Note:</b> This signal is not used in RMII mode.
	PHY Address 2 Configuration Strap	<u>PHYAD2</u>	VIS (PD)	Combined with PHYAD0 and PHYAD1, this configuration strap sets the transceiver's SMI address.  See <a href="#">Note 2.1</a> for more information on configuration straps. <b>Note:</b> Refer to <a href="#">Section 3.7.1, "PHYAD[2:0]: PHY Address Configuration,"</a> on <a href="#">page 39</a> for additional information.
1	Receive Error	RXER	VO8	This signal is asserted to indicate that an error was detected somewhere in the frame presently being transferred from the transceiver. This signal is also used in EEE mode as RXER when RXDV = 1, and as LPI when RXDV = 0. <b>Note:</b> This signal is optional in RMII mode.
	Receive Data 4 (MII Mode)	RXD4	VO8	In Symbol Interface (5B decoding) mode, this signal is the MII Receive Data 4 signal, the MSB of the received 5-bit symbol code-group. <b>Note:</b> Unless configured to the Symbol Interface mode, this pin functions as RXER.
	PHY Address 0 Configuration Strap	<u>PHYAD0</u>	VIS (PD)	Combined with PHYAD1 and PHYAD2, this configuration strap sets the transceiver's SMI address.  See <a href="#">Note 2.1</a> for more information on configuration straps. <b>Note:</b> Refer to <a href="#">Section 3.7.1, "PHYAD[2:0]: PHY Address Configuration,"</a> on <a href="#">page 39</a> for additional information.
1	Receive Clock (MII Mode)	RXCLK	VO8	In MII mode, this pin is the receive clock output. <ul style="list-style-type: none"> <li>■ MII (100BASE-TX): 25 MHz</li> <li>■ MII (10BASE-T): 2.5 MHz</li> </ul>
	PHY Address 1 Configuration Strap	<u>PHYAD1</u>	VIS (PD)	Combined with PHYAD0 and PHYAD2, this configuration strap sets the transceiver's SMI address.  See <a href="#">Note 2.1</a> for more information on configuration straps. <b>Note:</b> Refer to <a href="#">Section 3.7.1, "PHYAD[2:0]: PHY Address Configuration,"</a> on <a href="#">page 39</a> for additional information.
1	Receive Data Valid	RXDV	VO8	Indicates that recovered and decoded data is available on the RXD pins.

## Datasheet

Table 2.1 MII/RMII Signals (continued)

NUM PINS	NAME	SYMBOL	BUFFER TYPE	DESCRIPTION
1	Collision Detect (MII Mode)	COL	VO8	This signal is asserted to indicate detection of a collision condition in MII mode.
	Carrier Sense / Receive Data Valid (RMII Mode)	CRS_DV	VO8	This signal is asserted to indicate the receive medium is non-idle in RMII mode. When a 10BASE-T packet is received, CRS_DV is asserted, but RXD[1:0] is held low until the SFD byte (10101011) is received. <b>Note:</b> Per the RMII standard, transmitted data is not looped back onto the receive data pins in 10BASE-T half-duplex mode.
	PHY Operating Mode 2 Configuration Strap	<u>MODE2</u>	VIS (PU)	Combined with MODE0 and MODE1, this configuration strap sets the default PHY mode. See <a href="#">Note 2.1</a> for more information on configuration straps. <b>Note:</b> Refer to <a href="#">Section 3.7.2, "MODE[2:0]: Mode Configuration,"</a> on page 40 for additional details.
1	Carrier Sense (MII Mode)	CRS	VO8 (PD)	This signal indicates detection of a carrier in MII mode.

**Note 2.1** Configuration strap values are latched on power-on reset and system reset. Configuration straps are identified by an underlined symbol name. Signals that function as configuration straps must be augmented with an external resistor when connected to a load. Refer to [Section 3.7, "Configuration Straps,"](#) on page 39 for additional information.

Table 2.2 LED Pins

NUM PINS	NAME	SYMBOL	BUFFER TYPE	DESCRIPTION
1	LED 1	LED1	O12	<p>This pin can be used to indicate link activity, link speed, nINT, or nPME as configured via the <a href="#">LED1 Function Select</a> field of the <a href="#">Wakeup Control and Status Register (WUCSR)</a>.</p> <p><b>Note:</b> Refer to <a href="#">Section 3.8.1, "LEDs,"</a> on <a href="#">page 43</a> and <a href="#">Section 3.8.4, "Wake on LAN (WoL),"</a> on <a href="#">page 48</a> for additional LED information.</p>
	Interrupt Output	nINT	O12	<p>Active low interrupt output.</p> <p><b>Note:</b> By default, the nINT signal is output on the nINT/TXER/TXD4 pin. The nINT signal can be optionally configured to output on the LED1 or LED2 pins. Refer to <a href="#">Section 3.6, "Interrupt Management,"</a> on <a href="#">page 36</a> for additional details on device interrupts.</p>
	Power Management Event Output	nPME	O12	<p>Active low Power Management Event (PME) output.</p> <p><b>Note:</b> The nPME signal can be optionally configured to output on the LED1, LED2, or RXD2/nPME/nINTSEL pins. Refer to <a href="#">Section 3.8.4, "Wake on LAN (WoL),"</a> on <a href="#">page 48</a> for additional nPME and WoL information.</p>
	Regulator Off Configuration Strap	<u>REGOFF</u>	IS (PD)	<p>This configuration strap is used to disable the internal 1.2 V regulator. When the regulator is disabled, external 1.2 V must be supplied to VDDCR.</p> <ul style="list-style-type: none"> <li>■ When <u>REGOFF</u> is pulled high to VDD2A with an external resistor, the internal regulator is disabled.</li> <li>■ When <u>REGOFF</u> is floating or pulled low, the internal regulator is enabled (default).</li> </ul> <p>See <a href="#">Note 2.2</a> for more information on configuration straps.</p> <p><b>Note:</b> Refer to <a href="#">Section 3.7.4, "REGOFF: Internal +1.2 V Regulator Configuration,"</a> on <a href="#">page 41</a> for additional details.</p>

## Datasheet

Table 2.2 LED Pins (continued)

NUM PINS	NAME	SYMBOL	BUFFER TYPE	DESCRIPTION
1	LED 2	LED2	O12	This pin can be used to indicate link activity, link speed, nINT, or nPME as configured via the LED2 Function Select field of the Wakeup Control and Status Register (WUCSR). <b>Note:</b> Refer to <a href="#">Section 3.8.1, "LEDs,"</a> on page 43 and <a href="#">Section 3.8.4, "Wake on LAN (WoL),"</a> on page 48 for additional LED information.
	Interrupt Output	nINT	O12	Active low interrupt output. <b>Note:</b> By default, the nINT signal is output on the nINT/TXER/TXD4 pin. The nINT signal can be optionally configured to output on the LED1 or LED2 pins. Refer to <a href="#">Section 3.6, "Interrupt Management,"</a> on page 36 for additional details on device interrupts.
	Power Management Event Output	nPME	O12	Active low Power Management Event (PME) output. <b>Note:</b> The nPME signal can be optionally configured to output on the LED1, LED2, or RXD2/nPME/nINTSEL pins. Refer to <a href="#">Section 3.8.4, "Wake on LAN (WoL),"</a> on page 48 for additional nPME and WoL information.
	nINT/TXER/TXD4 Function Select Configuration Strap	<u>nINTSEL</u>	IS (PU)	This configuration strap selects the mode of the nINT/TXER/TXD4 pin. <ul style="list-style-type: none"><li>■ When <u>nINTSEL</u> is floated or pulled to VDD2A, nINT is selected for operation on the nINT/TXER/TXD4 pin (default).</li><li>■ When <u>nINTSEL</u> is pulled low to VSS, TXER/TXD4 is selected for operation on the nINT/TXER/TXD4 pin.</li></ul> See <a href="#">Note 2.2</a> for more information on configuration straps. <b>Note:</b> Refer to See <a href="#">Section 3.8.1.6, "nINTSEL and LED2 Polarity Selection,"</a> on page 47 for additional information.

**Note 2.2** Configuration strap values are latched on power-on reset and system reset. Configuration straps are identified by an underlined symbol name. Signals that function as configuration straps must be augmented with an external resistor when connected to a load. Refer to [Section 3.7, "Configuration Straps,"](#) on page 39 for additional information.

Table 2.3 Serial Management Interface (SMI) Pins

NUM PINS	NAME	SYMBOL	BUFFER TYPE	DESCRIPTION
1	SMI Data Input/Output	MDIO	VIS/ VO8 (PU)	Serial Management Interface data input/output
1	SMI Clock	MDC	VIS	Serial Management Interface clock

Table 2.4 Ethernet Pins

NUM PINS	NAME	SYMBOL	BUFFER TYPE	DESCRIPTION
1	Ethernet TX/RX Positive Channel 1	TXP	AIO	Transmit/Receive Positive Channel 1
1	Ethernet TX/RX Negative Channel 1	TXN	AIO	Transmit/Receive Negative Channel 1
1	Ethernet TX/RX Positive Channel 2	RXP	AIO	Transmit/Receive Positive Channel 2
1	Ethernet TX/RX Negative Channel 2	RXN	AIO	Transmit/Receive Negative Channel 2

Table 2.5 Miscellaneous Pins

NUM PINS	NAME	SYMBOL	BUFFER TYPE	DESCRIPTION
1	External Crystal Input	XTAL1	ICLK	External crystal input
	External Clock Input	CLKIN	ICLK	Single-ended clock oscillator input. <b>Note:</b> When using a single ended clock oscillator, XTAL2 should be left unconnected.
1	External Crystal Output	XTAL2	OCLK	External crystal output
1	External Reset	nRST	VIS (PU)	System reset. This signal is active low.



## Datasheet

Table 2.6 Analog Reference Pins

NUM PINS	NAME	SYMBOL	BUFFER TYPE	DESCRIPTION
1	External 1% Bias Resistor Input	RBIAS	AI	<p>This pin requires connection of a 12.1 k<math>\Omega</math> (1%) resistor to ground.</p> <p>Refer to the LAN8740A/LAN8740Ai reference schematic for connection information.</p> <p><b>Note:</b> The nominal voltage is 1.2 V and the resistor will dissipate approximately 1 mW of power.</p>

Table 2.7 Power Pins

NUM PINS	NAME	SYMBOL	BUFFER TYPE	DESCRIPTION
1	+1.8 V to +3.3 V Variable I/O Power	VDDIO	P	<p>+1.8 V to +3.3 V variable I/O power.</p> <p>Refer to the LAN8740A/LAN8740Ai reference schematic for connection information.</p>
1	+1.2 V Digital Core Power Supply	VDDCR	P	<p>Supplied by the on-chip regulator unless configured for regulator off mode via the <u>REGOFF</u> configuration strap.</p> <p>Refer to the LAN8740A/LAN8740Ai reference schematic for connection information.</p> <p><b>Note:</b> 1 <math>\mu</math>F and 470 pF decoupling capacitors in parallel to ground should be used on this pin.</p>
1	+3.3 V Channel 1 Analog Port Power	VDD1A	P	<p>+3.3 V Analog Port Power to Channel 1.</p> <p>Refer to the LAN8740A/LAN8740Ai reference schematic for connection information.</p>
1	+3.3 V Channel 2 Analog Port Power	VDD2A	P	<p>+3.3 V Analog Port Power to Channel 2 and the internal regulator.</p> <p>Refer to the LAN8740A/LAN8740Ai reference schematic for connection information.</p>
1	Ground	VSS	P	<p>Common ground. This exposed pad must be connected to the ground plane with a via array.</p>

## 2.1 Pin Assignments

Table 2.8 32-SQFN Package Pin Assignments

PIN NUM	PIN NAME	PIN NUM	PIN NAME
1	VDD2A	17	MDC
2	LED2/nINT/nPME/nINTSEL	18	nINT/TXER/TXD4
3	LED1/nINT/nPME/REGOFF	19	nRST
4	XTAL2	20	TXCLK
5	XTAL1/CLKIN	21	TXEN
6	VDDCR	22	TXD0
7	RXCLK/PHYAD1	23	TXD1
8	RXD3/PHYAD2	24	TXD2
9	RXD2/nPME/RMIISEL	25	TXD3
10	RXD1/MODE1	26	RXDV
11	RXD0/MODE0	27	VDD1A
12	VDDIO	28	TXN
13	RXER/RXD4/PHYAD0	29	TXP
14	CRS	30	RXN
15	COL/CRS_DV/MODE2	31	RXP
16	MDIO	32	RBIAS

## Datasheet

## 2.2 Buffer Types

Table 2.9 Buffer Types

BUFFER TYPE	DESCRIPTION
IS	Schmitt-triggered input
O12	Output with 12 mA sink and 12 mA source
VIS	Variable voltage Schmitt-triggered input
VO8	Variable voltage output with 8 mA sink and 8 mA source
VOD8	Variable voltage open-drain output with 8 mA sink
PU	50 $\mu$ A (typical) internal pull-up. Unless otherwise noted in the pin description, internal pull-ups are always enabled. <b>Note:</b> Internal pull-up resistors prevent unconnected inputs from floating. Do not rely on internal resistors to drive signals external to the device. When connected to a load that must be pulled high, an external resistor must be added.
PD	50 $\mu$ A (typical) internal pull-down. Unless otherwise noted in the pin description, internal pull-downs are always enabled. <b>Note:</b> Internal pull-down resistors prevent unconnected inputs from floating. Do not rely on internal resistors to drive signals external to the device. When connected to a load that must be pulled low, an external resistor must be added.
AI	Analog input
AIO	Analog bi-directional
ICLK	Crystal oscillator input pin
OCLK	Crystal oscillator output pin
P	Power pin

**Note:** The digital signals are not 5 V tolerant. Refer to [Section 5.1, "Absolute Maximum Ratings\\*,"](#) on [page 124](#) for additional buffer information.

**Note:** Sink and source capabilities are dependant on the VDDIO voltage. Refer to [Section 5.1, "Absolute Maximum Ratings\\*,"](#) on [page 124](#) for additional information.

## Chapter 3 Functional Description

This chapter provides functional descriptions of the various device features. These features have been categorized into the following sections:

- Transceiver
- Auto-Negotiation
- HP Auto-MDIX Support
- MAC Interface
- Serial Management Interface (SMI)
- Interrupt Management
- Configuration Straps
- Miscellaneous Functions
- Application Diagrams

### 3.1 Transceiver

#### 3.1.1 100BASE-TX Transmit

The 100BASE-TX transmit data path is shown in [Figure 3.1](#). Each major block is explained in the following subsections.

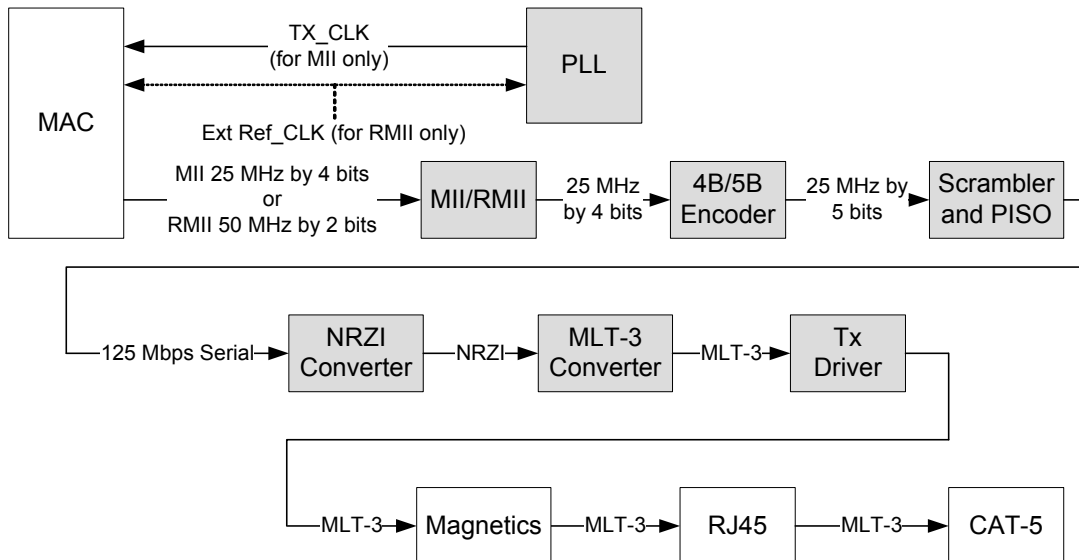

Figure 3.1 100BASE-TX Transmit Data Path

## Datasheet

**3.1.1.1 100BASE-TX Transmit Data Across the MII/RMII Interface**

For MII, the MAC controller drives the transmit data onto the TXD bus and asserts TXEN to indicate valid data. The data is latched by the transceiver's MII block on the rising edge of TXCLK. The data is in the form of 4-bit wide 25 MHz data.

For RMII, the MAC controller drives the transmit data onto the TXD bus and asserts TXEN to indicate valid data. The data is latched by the transceiver's RMII block on the rising edge of REF\_CLK. The data is in the form of 2-bit wide 50 MHz data.

**3.1.1.2 4B/5B Encoding**

The transmit data passes from the MII/RMII block to the 4B/5B encoder. This block encodes the data from 4-bit nibbles to 5-bit symbols (known as "code-groups") according to [Table 3.1](#). Each 4-bit data-nibble is mapped to 16 of the 32 possible code-groups. The remaining 16 code-groups are either used for control information or are not valid.

The first 16 code-groups are referred to by the hexadecimal values of their corresponding data nibbles, 0 through F. The remaining code-groups are given letter designations with slashes on either side. For example, an IDLE code-group is /I/, a transmit error code-group is /H/, etc.

**Table 3.1 4B/5B Code Table**

CODE GROUP	SYM	RECEIVER INTERPRETATION			TRANSMITTER INTERPRETATION		
11110	0	0	0000	DATA	0	0000	DATA
01001	1	1	0001		1	0001	
10100	2	2	0010		2	0010	
10101	3	3	0011		3	0011	
01010	4	4	0100		4	0100	
01011	5	5	0101		5	0101	
01110	6	6	0110		6	0110	
01111	7	7	0111		7	0111	
10010	8	8	1000		8	1000	
10011	9	9	1001		9	1001	
10110	A	A	1010		A	1010	
10111	B	B	1011		B	1011	
11010	C	C	1100		C	1100	
11011	D	D	1101		D	1101	
11100	E	E	1110		E	1110	
11101	F	F	1111		F	1111	
11111	I	IDLE			Sent after /T/R until TXEN		
11000	J	First nibble of SSD, translated to "0101" following IDLE, else RXER			Sent for rising TXEN		



Table 3.1 4B/5B Code Table (continued)

CODE GROUP	SYM	RECEIVER INTERPRETATION	TRANSMITTER INTERPRETATION
10001	K	Second nibble of SSD, translated to "0101" following J, else RXER	Sent for rising TXEN
01101	T	First nibble of ESD, causes de-assertion of CRS if followed by /R/, else assertion of RXER	Sent for falling TXEN
00111	R	Second nibble of ESD, causes deassertion of CRS if following /T/, else assertion of RXER	Sent for falling TXEN
00100	H	Transmit Error Symbol	Sent for rising TXER
00110	V	INVALID, RXER if during RXDV	INVALID
11001	V	INVALID, RXER if during RXDV	INVALID
00000	V	Indicates to receiver that the transmitter will be going to LPI	Sent due to LPI. Used to tell receiver before transmitter goes to LPI. Also used for refresh cycles during LPI.
00001	V	INVALID, RXER if during RXDV	INVALID
00010	V	INVALID, RXER if during RXDV	INVALID
00011	V	INVALID, RXER if during RXDV	INVALID
00101	V	INVALID, RXER if during RXDV	INVALID
01000	V	INVALID, RXER if during RXDV	INVALID
01100	V	INVALID, RXER if during RXDV	INVALID
10000	V	INVALID, RXER if during RXDV	INVALID

### 3.1.1.3 Scrambling

Repeated data patterns (especially the IDLE code-group) can have power spectral densities with large narrow-band peaks. Scrambling the data helps eliminate these peaks and spread the signal power more uniformly over the entire channel bandwidth. This uniform spectral density is required by FCC regulations to prevent excessive EMI from being radiated by the physical wiring.

The seed for the scrambler is generated from the transceiver address, [PHYAD](#), ensuring that in multiple-transceiver applications, such as repeaters or switches, each transceiver will have its own scrambler sequence.

The scrambler also performs the Parallel In Serial Out conversion (PISO) of the data.

### 3.1.1.4 NRZI and MLT-3 Encoding

The scrambler block passes the 5-bit wide parallel data to the NRZI converter where it becomes a serial 125 MHz NRZI data stream. The NRZI is encoded to MLT-3. MLT-3 is a tri-level code where a change in the logic level represents a code bit "1" and the logic output remaining at the same level represents a code bit "0".

## Datasheet

**3.1.1.5 100M Transmit Driver**

The MLT3 data is then passed to the analog transmitter, which drives the differential MLT-3 signal, on outputs TXP and TXN, to the twisted pair media across a 1:1 ratio isolation transformer. The 10BASE-T and 100BASE-TX signals pass through the same transformer so that common “magnetics” can be used for both. The transmitter drives into the 100  $\Omega$  impedance of the CAT-5 cable. Cable termination and impedance matching require external components.

**3.1.1.6 100M Phase Lock Loop (PLL)**

The 100M PLL locks onto reference clock and generates the 125 MHz clock used to drive the 125 MHz logic and the 100BASE-TX transmitter.

**3.1.2 100BASE-TX Receive**

The 100BASE-TX receive data path is shown in [Figure 3.2](#). Each major block is explained in the following subsections.

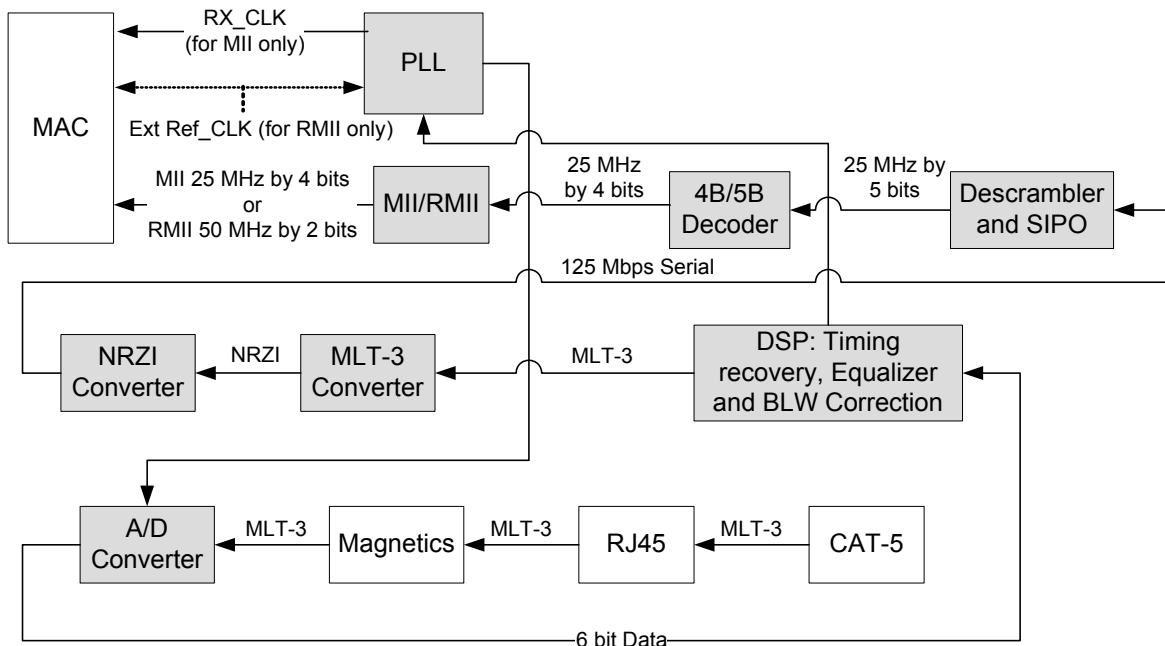

**Figure 3.2 100BASE-TX Receive Data Path**

**3.1.2.1 100M Receive Input**

The MLT-3 from the cable is fed into the transceiver (on inputs RXP and RXN) via a 1:1 ratio transformer. The ADC samples the incoming differential signal at a rate of 125M samples per second. Using a 64-level quantizer, it generates 6 digital bits to represent each sample. The DSP adjusts the gain of the ADC according to the observed signal levels such that the full dynamic range of the ADC can be used.

### 3.1.2.2 Equalizer, Baseline Wander Correction and Clock and Data Recovery

The 6 bits from the ADC are fed into the DSP block. The equalizer in the DSP section compensates for phase and amplitude distortion caused by the physical channel consisting of magnetics, connectors, and CAT-5 cable. The equalizer can restore the signal for any good-quality CAT-5 cable between 1 m and 100 m.

If the DC content of the signal is such that the low-frequency components fall below the low frequency pole of the isolation transformer, then the droop characteristics of the transformer will become significant and Baseline Wander (BLW) on the received signal will result. To prevent corruption of the received data, the transceiver corrects for BLW and can receive the ANSI X3.263-1995 FDDI TP-PMD defined "killer packet" with no bit errors.

The 100M PLL generates multiple phases of the 125 MHz clock. A multiplexer, controlled by the timing unit of the DSP, selects the optimum phase for sampling the data. This is used as the received recovered clock. This clock is used to extract the serial data from the received signal.

### 3.1.2.3 NRZI and MLT-3 Decoding

The DSP generates the MLT-3 recovered levels that are fed to the MLT-3 converter. The MLT-3 is then converted to an NRZI data stream.

### 3.1.2.4 Descrambling

The descrambler performs an inverse function to the scrambler in the transmitter and also performs the Serial In Parallel Out (SIPO) conversion of the data.

During reception of IDLE (/I/) symbols, the descrambler synchronizes its descrambler key to the incoming stream. Once synchronization is achieved, the descrambler locks on this key and is able to descramble incoming data.

Special logic in the descrambler ensures synchronization with the remote transceiver by searching for IDLE symbols within a window of 4000 bytes (40  $\mu$ s). This window ensures that a maximum packet size of 1514 bytes, allowed by the IEEE 802.3 standard, can be received with no interference. If no IDLE-symbols are detected within this time-period, receive operation is aborted and the descrambler re-starts the synchronization process.

### 3.1.2.5 Alignment

The de-scrambled signal is then aligned into 5-bit code-groups by recognizing the /J/K/ Start-of-Stream Delimiter (SSD) pair at the start of a packet. Once the code-word alignment is determined, it is stored and utilized until the next start of frame.

### 3.1.2.6 5B/4B Decoding

The 5-bit code-groups are translated into 4-bit data nibbles according to the 4B/5B table. The translated data is presented on the RXD[3:0] signal lines. The SSD, /J/K/, is translated to "0101 0101" as the first 2 nibbles of the MAC preamble. Reception of the SSD causes the transceiver to assert the receive data valid signal, indicating that valid data is available on the RXD bus. Successive valid code-groups are translated to data nibbles. Reception of either the End of Stream Delimiter (ESD) consisting of the /T/R/ symbols, or at least two /I/ symbols causes the transceiver to de-assert the carrier sense and receive data valid signals.

**Note:** These symbols are not translated into data.