



Chipsmall Limited consists of a professional team with an average of over 10 year of expertise in the distribution of electronic components. Based in Hongkong, we have already established firm and mutual-benefit business relationships with customers from,Europe,America and south Asia,supplying obsolete and hard-to-find components to meet their specific needs.

With the principle of “Quality Parts,Customers Priority,Honest Operation,and Considerate Service”,our business mainly focus on the distribution of electronic components. Line cards we deal with include Microchip,ALPS,ROHM,Xilinx,Pulse,ON,Everlight and Freescale. Main products comprise IC,Modules,Potentiometer,IC Socket,Relay,Connector.Our parts cover such applications as commercial,industrial, and automotives areas.

We are looking forward to setting up business relationship with you and hope to provide you with the best service and solution. Let us make a better world for our industry!



Contact us

Tel: +86-755-8981 8866 Fax: +86-755-8427 6832

Email & Skype: info@chipsmall.com Web: www.chipsmall.com

Address: A1208, Overseas Decoration Building, #122 Zhenhua RD., Futian, Shenzhen, China



10/100 Non-PCI Ethernet Single Chip MAC + PHY

Highlights

- Single Chip Ethernet Controller
- Dual Speed - 10/100 Mbps
- Fully Supports Full Duplex Switched Ethernet
- Supports Burst Data Transfer
- 8 Kbytes Internal Memory for Receive and Transmit FIFO Buffers
- Enhanced Power Management Features
- Optional Configuration via Serial EEPROM Interface
- Supports 8, 16 and 32 Bit CPU Accesses
- Internal 32 Bit Wide Data Path (Into Packet Buffer Memory)
- Built-in Transparent Arbitration for Slave Sequential Access Architecture
- Flat MMU Architecture with Symmetric Transmit and Receive Structures and Queues
- 3.3V Operation with 5V Tolerant IO Buffers (See Pin List Description for Additional Details)
- Single 25 MHz Reference Clock for Both PHY and MAC
- External 25Mhz-output pin for an external PHY supporting PHYs physical media.
- Low Power CMOS Design
- Supports Multiple Embedded Processor Host Interfaces
 - ARM
 - SH
 - Power PC
 - Coldfire
 - 680X0, 683XX
 - MIPS R3000
- 3.3V MII (Media Independent Interface) MAC-PHY Interface Running at Nibble Rate
- MII Management Serial Interface
- 128-Pin QFP RoHS compliant package
- 128-Pin TQFP 1.0 mm height RoHS compliant package
- Commercial Temperature Range from 0°C to 70°C (LAN91C111)
- Industrial Temperature Range from -40°C to 85°C (LAN91C111i)

Network Interface

- Fully Integrated IEEE 802.3/802.3u-100Base-TX/10Base-T Physical Layer
- Auto-Negotiation: 10/100, Full / Half Duplex
- On Chip Wave Shaping - No External Filters Required
- Adaptive Equalizer
- Baseline Wander Correction
- LED Outputs (User selectable – Up to 2 LED functions at one time)
 - Link
 - Activity
 - Full Duplex
 - 10/100
 - Transmit
 - Receive

TO OUR VALUED CUSTOMERS

It is our intention to provide our valued customers with the best documentation possible to ensure successful use of your Microchip products. To this end, we will continue to improve our publications to better suit your needs. Our publications will be refined and enhanced as new volumes and updates are introduced.

If you have any questions or comments regarding this publication, please contact the Marketing Communications Department via E-mail at docerrors@microchip.com. We welcome your feedback.

Most Current Data Sheet

To obtain the most up-to-date version of this data sheet, please register at our Worldwide Web site at:

<http://www.microchip.com>

You can determine the version of a data sheet by examining its literature number found on the bottom outside corner of any page. The last character of the literature number is the version number, (e.g., DS30000000A is version A of document DS30000000).

Errata

An errata sheet, describing minor operational differences from the data sheet and recommended workarounds, may exist for current devices. As device/documentation issues become known to us, we will publish an errata sheet. The errata will specify the revision of silicon and revision of document to which it applies.

To determine if an errata sheet exists for a particular device, please check with one of the following:

- Microchip's Worldwide Web site; <http://www.microchip.com>
- Your local Microchip sales office (see last page)

When contacting a sales office, please specify which device, revision of silicon and data sheet (include -literature number) you are using.

Customer Notification System

Register on our web site at www.microchip.com to receive the most current information on all of our products.

Table of Contents

1.0 General Description	4
2.0 Pin Configurations	5
3.0 Block Diagrams	7
4.0 Signal Descriptions	10
5.0 Description of Pin Functions	11
6.0 Signal Description Parameters	15
7.0 Functional Description	16
8.0 MAC Data Structures and Registers	38
9.0 PHY MII Registers	65
10.0 Software Driver and Hardware Sequence Flow	77
11.0 Board Setup Information	88
12.0 Application Considerations	90
13.0 Operational Description	97
14.0 Timing Diagrams	102
15.0 Package Outlines	118
Appendix A: Data Sheet Revision History	120
The Microchip Web Site	121
Customer Change Notification Service	121
Customer Support	121
Product Identification System	122

LAN91C111

1.0 GENERAL DESCRIPTION

The Microchip LAN91C111 is designed to facilitate the implementation of a third generation of Fast Ethernet connectivity solutions for embedded applications. For this third generation of products, flexibility and integration dominate the design requirements. The LAN91C111 is a mixed signal Analog/Digital device that implements the MAC and PHY portion of the CSMA/CD protocol at 10 and 100 Mbps. The design will also minimize data throughput constraints utilizing a 32-bit, 16-bit or 8-bit bus Host interface in embedded applications.

The total internal memory FIFO buffer size is 8 Kbytes, which is the total chip storage for transmit and receive operations.

The Microchip LAN91C111 is software compatible with the LAN9000 family of products.

Memory management is handled using a patented optimized MMU (Memory Management Unit) architecture and a 32-bit wide internal data path. This I/O mapped architecture can sustain back-to-back frame transmission and reception for superior data throughput and optimal performance. It also dynamically allocates buffer memory in an efficient buffer utilization scheme, reducing software tasks and relieving the host CPU from performing these housekeeping functions.

The Microchip LAN91C111 provides a flexible slave interface for easy connectivity with industry-standard buses. The Bus Interface Unit (BIU) can handle synchronous as well as asynchronous transfers, with different signals being used for each one. Asynchronous bus support for ISA is supported even though ISA cannot sustain 100 Mbps traffic. Fast Ethernet data rates are attainable for ISA-based nodes on the basis of the aggregate traffic benefits.

Two different interfaces are supported on the network side. The first Interface is a standard Magnetics transmit/receive pair interfacing to 10/100Base-T utilizing the internal physical layer block. The second interface follows the MII (Media Independent Interface) specification standard, consisting of 4 bit wide data transfers at the nibble rate. This interface is applicable to 10 Mbps standard Ethernet or 100 Mbps Ethernet networks. Three of the LAN91C111's pins are used to interface to the two-line MII serial management protocol.

The Microchip LAN91C111 integrates IEEE 802.3 Physical Layer for twisted pair Ethernet applications. The PHY can be configured for either 100 Mbps (100Base-TX) or 10 Mbps (10Base-T) Ethernet operation. The Analog PHY block consists of a 4B5B/Manchester encoder/decoder, scrambler/de-scrambler, transmitter with wave shaping and output driver, twisted pair receiver with on chip equalizer and baseline wander correction, clock and data recovery, Auto-Negotiation, controller interface (MII), and serial port (MI). Internal output wave shaping circuitry and on-chip filters eliminate the need for external filters normally required in 100Base-TX and 10Base-T applications.

The LAN91C111 can automatically configure itself for 100 or 10 Mbps and Full or Half Duplex operation with the on-chip Auto-Negotiation algorithm. The LAN91C111 is ideal for media interfaces for embedded application desiring Ethernet connectivity as well as 100Base-TX/10Base-T adapter cards, motherboards, repeaters, switching hubs. The LAN91C111 operates from a single 3.3V supply. The inputs and outputs of the host Interface are 5V tolerant and will directly interface to other 5V devices.

2.0 PIN CONFIGURATIONS

FIGURE 2-1: PIN CONFIGURATION - LAN91C111-FAEST 128-PIN TQFP

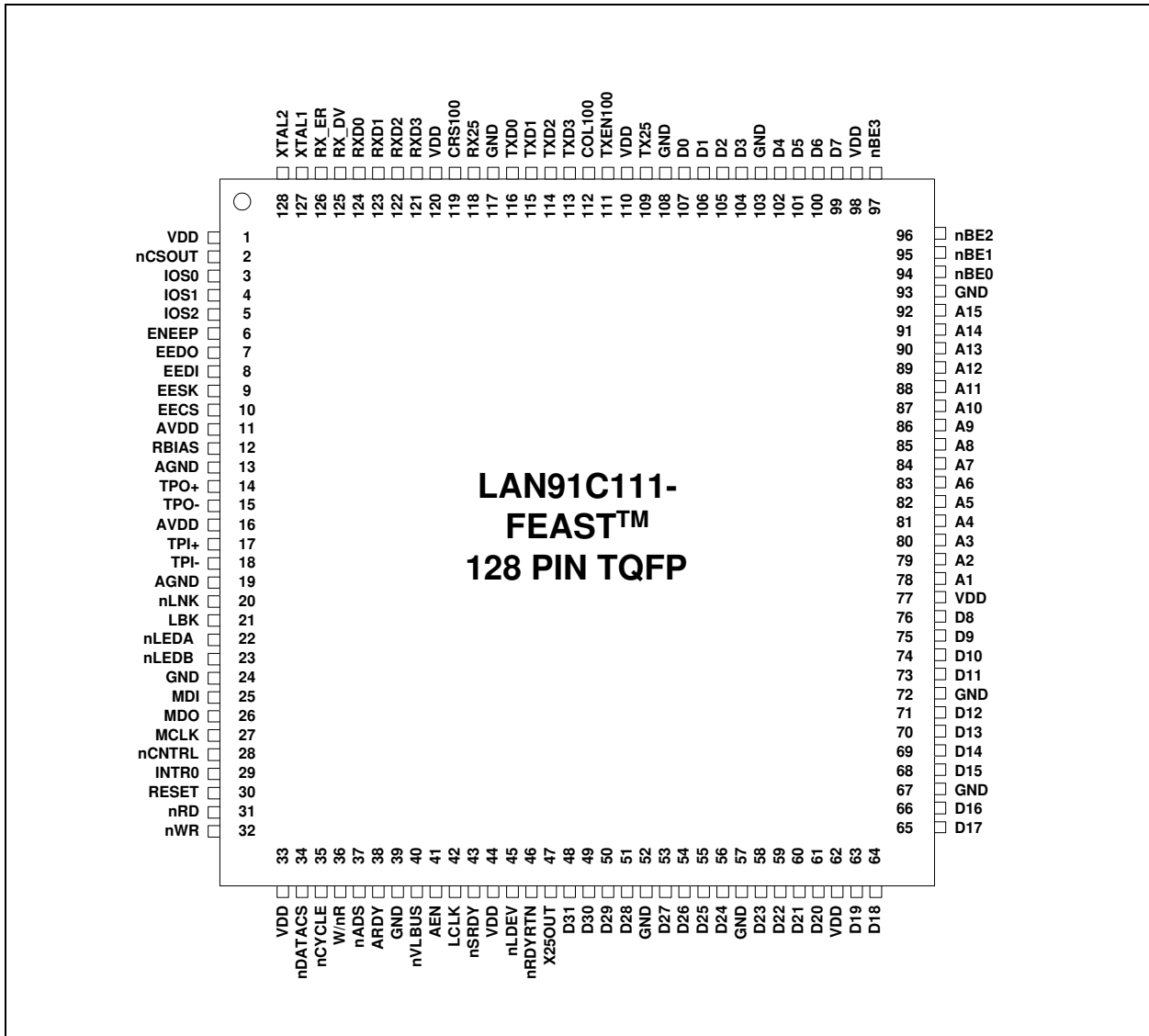

LAN91C111

FIGURE 2-2: PIN CONFIGURATION - LAN91C111-FEAST 128-PIN QFP

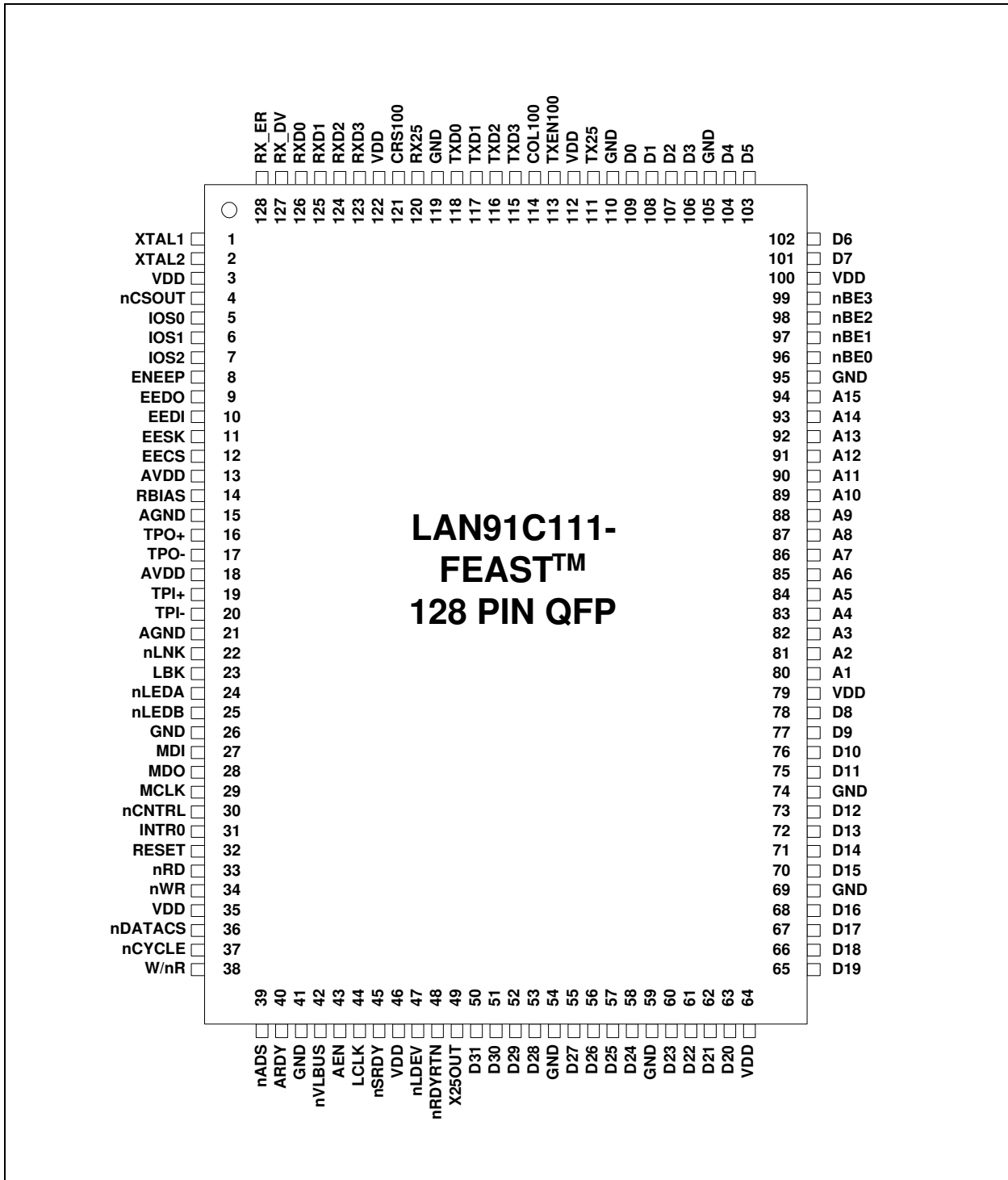

3.0 BLOCK DIAGRAMS

The diagram shown in [Figure 3-1, "Basic Functional Block Diagram"](#), describes the device basic functional blocks. The Microchip LAN91C111 is a single chip solution for embedded designs with minimal Host and external supporting devices required to implement 10/100 Ethernet connectivity solutions.

The optional Serial EEPROM is used to store information relating to default IO offset parameters as well as which of the Interrupt line are used by the host.

FIGURE 3-1: BASIC FUNCTIONAL BLOCK DIAGRAM

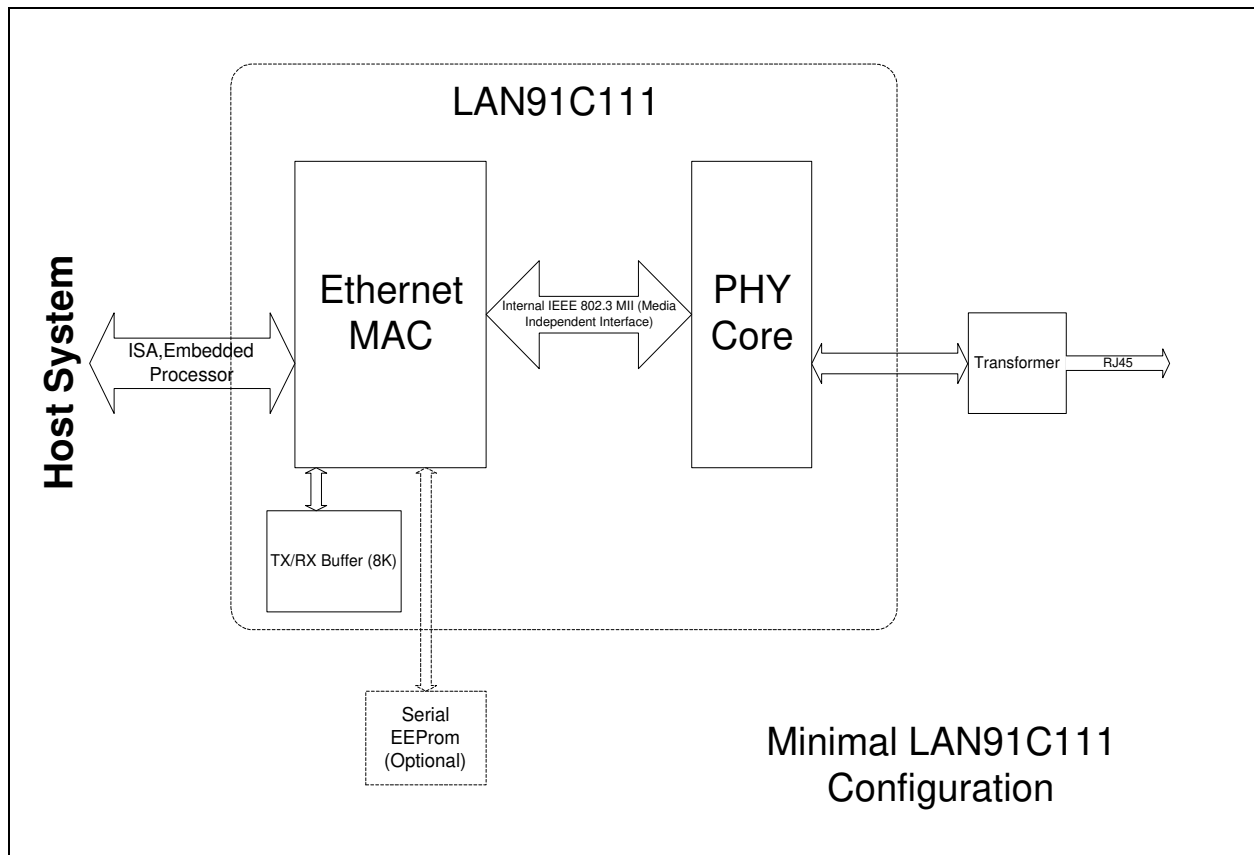

LAN91C111

FIGURE 3-2: BLOCK DIAGRAM

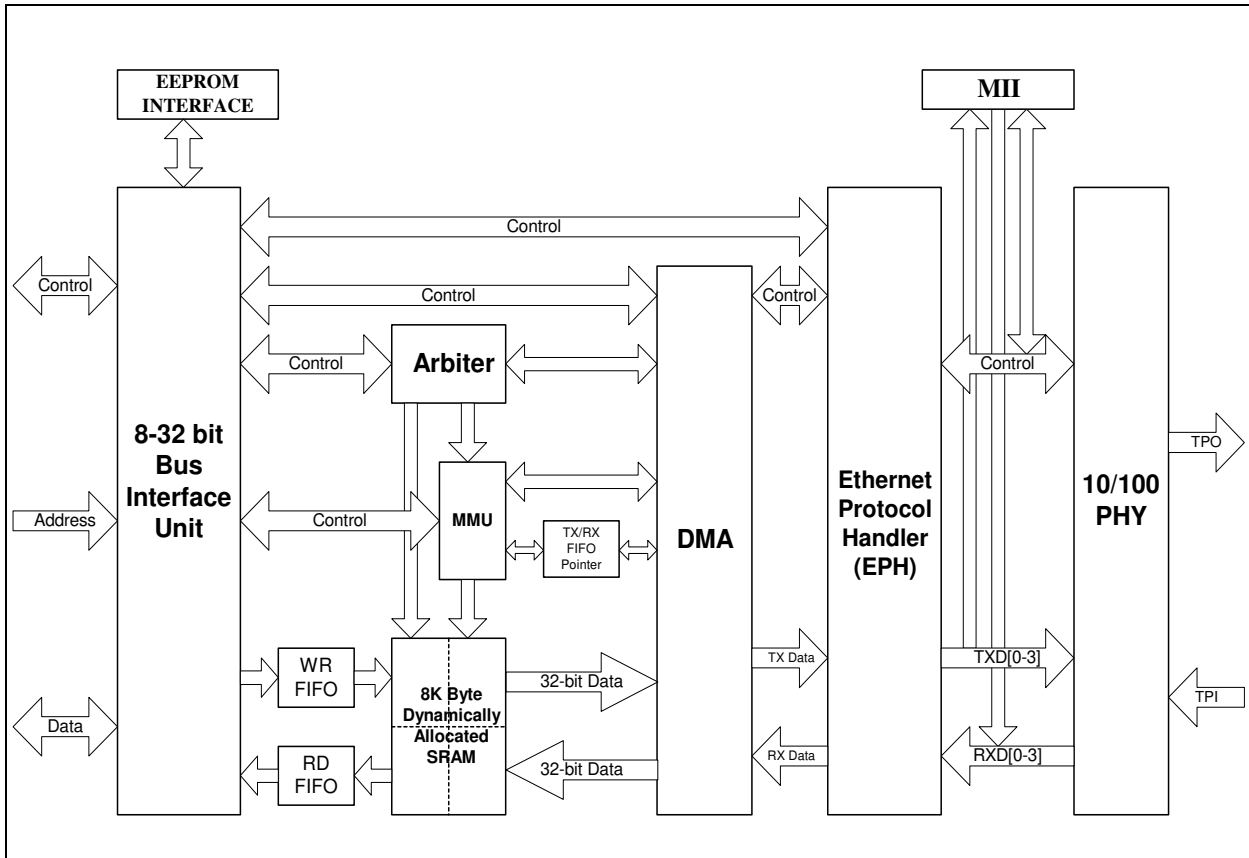

The diagram shown in Figure 3-2 describes the supported Host interfaces, which include ISA or Generic Embedded. The Host interface is an 8, 16 or 32 bit wide address / data bus with extensions for 32, 16 and 8 bit embedded RISC and ARM processors.

The figure shown next page describes the Microchip LAN91C111 functional blocks required to integrate a 10/100 Ethernet Physical layer framer to the internal MAC.

FIGURE 3-3: LAN91C111 PHYSICAL LAYER TO INTERNAL MAC BLOCK DIAGRAM

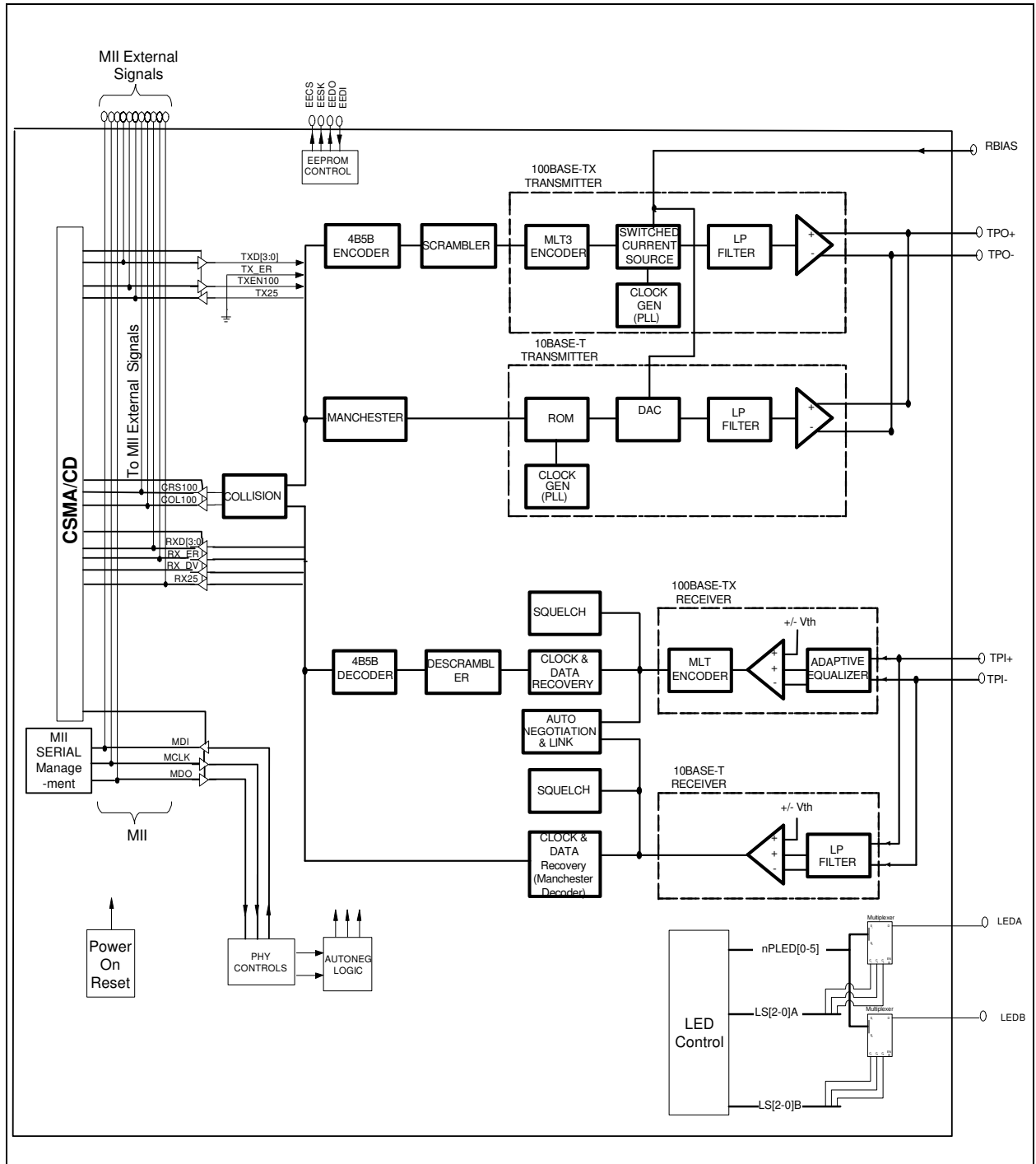

LAN91C111

4.0 SIGNAL DESCRIPTIONS

TABLE 4-1: LAN91C111 PIN REQUIREMENTS (128 PIN QFP AND 1.0MM TQFP PACKAGE)

Function	Pin Symbols	Number of Pins
System Address Bus	A1-A15, AEN, nBE0-nBE3	20
System Data Bus	D0-D31	32
System Control Bus	RESET, nADS, LCLK, ARDY, nRDYRTN, nSRDY, INTR0, nLDEV, nRD, nWR, nDATACS, nCYCLE, W/nR, nVLBUS	14
Serial EEPROM	EEDI, EEDO, EECS, EESK, ENEEP, IOS0-IOS2	8
LEDs	nLEDA, nLEDB	2
PHY	TPO+, TPO-, TPI+, TPI-, nLNK, LBK, nCNTRL, RBIAS	8
Crystal Oscillator	XTAL1, XTAL2	2
Power	VDD, AVDD	10
Ground	GND, AGND	12
Physical Interface (MII)	TXEN100, CRS100, COL100, RX_DV, RX_ER, TXD0-TXD3, RXD0-RXD3, MDI, MDO, MCLK, RX25, TX25	18
MISC	nCSOUT, X25OUT	2
TOTAL		128

5.0 DESCRIPTION OF PIN FUNCTIONS

Pin No.		Name	Symbol	Buffer Type	Description
TQFP	QFP				
81-92	83-94	Address	A4-A15	I**	Input. Decoded by LAN91C111 to determine access to its registers.
78-80	80-82	Address	A1-A3	I**	Input. Used by LAN91C111 for internal register selection.
41	43	Address Enable	AEN	I**	Input. Used as an address qualifier. Address decoding is only enabled when AEN is low.
94-97	96-99	nByte Enable	nBE0-nBE3	I**	Input. Used during LAN91C111 register accesses to determine the width of the access and the register(s) being accessed. nBE0-nBE3 are ignored when nDATACS is low (burst accesses) because 32 bit transfers are assumed.
107-104, 102-99, 76-73, 71-68, 66-63, 61-58, 56-53, 51-48	109-106, 104-101, 78-75, 73-70, 68-65, 63-60, 58-55, 53-50	Data Bus	D0-D31	I/O24**	Bidirectional. 32 bit data bus used to access the LAN91C111's internal registers. Data bus has weak internal pullups. Supports direct connection to the system bus without external buffering. For 16 bit systems, only D0-D15 are used.
30	32	Reset	RESET	IS**	Input. When this pin is asserted high, the controller performs an internal system (MAC & PHY) reset. It programs all the registers to their default value, the controller will read the EEPROM device through the EEPROM interface (Note 5-1). This input is not considered active unless it is active for at least 100ns to filter narrow glitches.
37	39	nAddress Strobe	nADS	IS**	Input. For systems that require address latching, the rising edge of nADS indicates the latching moment for A1-A15 and AEN. All LAN91C111 internal functions of A1-A15, AEN are latched except for nLDEV decoding.
35	37	nCycle	nCYCLE	I**	Input. This active low signal is used to control LAN91C111 EISA burst mode synchronous bus cycles.
36	38	Write/nRead	W/nR	IS**	Input. Defines the direction of synchronous cycles. Write cycles when high, read cycles when low.
40	42	nVL Bus Access	nVLBUS	I with pullup**	Input. When low, the LAN91C111 synchronous bus interface is configured for VL Bus accesses. Otherwise, the LAN91C111 is configured for EISA DMA burst accesses. Does not affect the asynchronous bus interface.
42	44	Local Bus Clock	LCLK	I**	Input. Used to interface synchronous buses. Maximum frequency is 50 MHz. Limited to 8.33 MHz for EISA DMA burst mode. This pin should be tied high if it is in asynchronous mode.

LAN91C111

Pin No.		Name	Symbol	Buffer Type	Description
TQFP	QFP				
38	40	Asynchronous Ready	ARDY	OD16	Open drain output. ARDY may be used when interfacing asynchronous buses to extend accesses. Its rising (access completion) edge is controlled by the XTAL1 clock and, therefore, asynchronous to the host CPU or bus clock. ARDY is negated during Asynchronous cycle when one of the following conditions occurs: No Wait Bit in the Configuration Register is cleared. Read FIFO contains less than 4 bytes when read. Write FIFO is full when write.
43	45	nSynchronous Ready	nSRDY	O16	Output. This output is used when interfacing synchronous buses and nVLBUS=0 to extend accesses. This signal remains normally inactive, and its falling edge indicates completion. This signal is synchronous to the bus clock LCLK.
46	48	nReady Return	nRDYRTN	I**	Input. This input is used to complete synchronous read cycles. In EISA burst mode it is sampled on falling LCLK edges, and synchronous cycles are delayed until it is sampled high.
29	31	Interrupt	INTR0	O24	Interrupt Output – Active High, it's used to interrupt the Host on a status event. Note: The selection bits used to be determined by the value of INT SEL 1-0 bits in the Configuration Register are no longer required and have been set to reserved in this revision of the FEAST family of devices.
45	47	nLocal Device	nLDEV	O16	Output. This active low output is asserted when AEN is low and A4-A15 decode to the LAN91C111 address programmed into the high byte of the Base Address Register. nLDEV is a combinatorial decode of unlatched address and AEN signals.
31	33	nRead Strobe	nRD	IS**	Input. Used in asynchronous bus interfaces.
32	34	nWrite Strobe	nWR	IS**	Input. Used in asynchronous bus interfaces.
34	36	nData Path Chip Select	nDATACS	I with pullup**	Input. When nDATACS is low, the Data Path can be accessed regardless of the values of AEN, A1-A15 and the content of the BANK SELECT Register. nDATACS provides an interface for bursting to and from the LAN91C111 32 bits at a time.
9	11	EEPROM Clock	EESK	O4	Output. 4 μ sec clock used to shift data in and out of the serial EEPROM.
10	12	EEPROM Select	EECS	O4	Output. Serial EEPROM chip select. Used for selection and command framing of the serial EEPROM.

LAN91C111

Pin No.		Name	Symbol	Buffer Type	Description
TQFP	QFP				
7	9	EEPROM Data Out	EEDO	O4	Output. Connected to the DI input of the serial EEPROM.
8	10	EEPROM Data In	EEDI	I with pulldown**	Input. Connected to the DO output of the serial EEPROM.
3-5	5-7	I/O Base	IOS0-IOS2	I with pullup**	Input. External switches can be connected to these lines to select between predefined EEPROM configurations.
6	8	Enable EEPROM	ENEPP	I with pullup**	Input. Enables (when high or open) LAN91C111 accesses to the serial EEPROM. Must be grounded if no EEPROM is connected to the LAN91C111.
127, 128	1, 2	Crystal 1 Crystal 2	XTAL1 XTAL2	Iclk**	An external 25 MHz crystal is connected across these pins. If a TTL clock is supplied instead, it should be connected to XTAL1 and XTAL2 should be left open. XTAL1 is the 5V tolerant input of the internal amplifier and XTAL2 is the output of the internal amplifier.
1, 33, 44, 62, 77, 98, 110, 120	3, 35, 46, 64, 79, 100, 112, 122	Power	VDD		+3.3V Power supply pins.
11, 16	13, 18	Analog Power	AVDD		+3.3V Analog power supply pins.
24, 39, 52, 57, 67, 72, 93, 103, 108, 117	26, 41, 54, 59, 69, 74, 95, 105, 110, 119	Ground	GND		Ground pins.
13, 19	15, 21	Analog Ground	AGND		Analog Ground pins
21	23	Loopback	LBK	O4	Output. Active when LOOP bit is set (TCR bit 1).
20	22	nLink Status	nLNK	I with pullup	Input. General-purpose input port used to convey LINK status (EPHSR bit 14).
28	30	nCNTRL	nCNTRL	O12	General Purpose Control Pin
47	49	X25out	X25out	O12	25Mhz Output to external PHY
111	113	Transmit Enable 100 Mbps	TXEN100	O12	Output to MII PHY. Envelope to 100 Mbps transmission.
119	121	Carrier Sense 100 Mbps	CRS100	I with pulldown	Input from MII PHY. Envelope of packet reception used for deferral and backoff purposes.
125	127	Receive Data Valid	RX_DV	I with pulldown	Input from MII PHY. Envelope of data valid reception. Used for receive data framing.
112	114	Collision Detect 100 Mbps	COL100	I with pulldown	Input from MII PHY. Collision detection input.

LAN91C111

Pin No.		Name	Symbol	Buffer Type	Description
TQFP	QFP				
113-116	115-118	Transmit Data	TXD3-TXD0	O12	Outputs. Transmit Data nibble to MII PHY.
109	111	Transmit Clock	TX25	I with pullup	Input. Transmit clock input from MII. Nibble rate clock (25MHz for 100Mbps & 2.5MHz for 10Mbps).
118	120	Receive Clock	RX25	I with pullup	Input. Receive clock input from MII PHY. Nibble rate clock. (25MHz for 100Mbps & 2.5MHz for 10Mbps).
121-124	123-126	Receive Data	RXD3-RXD0	I with pullup	Inputs. Received Data nibble from MII PHY.
25	27	Management Data Input	MDI	I with pulldown	MIl management data input.
26	28	Management Data Output	MDO	O4	MIl management data output.
27	29	Management Clock	MCLK	O4	MIl management clock.
126	128	Receive Error	RX_ER	I with pulldown	Input. Indicates a code error detected by PHY. Used by the LAN91C111 to discard the packet being received. The error indication reported for this event is the same as a bad CRC (Receive Status Word bit 13).
2	4	nChip Select Output	nCSOUT	O4	Output. Chip Select provided for mapping of PHY functions into LAN91C111 decoded space. Active on accesses to LAN91C111's eight lower addresses when the BANK SELECTED is 7.
12	14	External Resistor	RBIAS	NA	Transmit Current Set. An external resistor connected between this pin and GND will set the output current for the TP transmit outputs
14	16		TPO+	O/I	Twisted Pair Transmit Output, Positive.
15	17		TPO-	O/I	Twisted Pair Transmit Output, Negative
17	19		TPI+	I/O	Twisted Pair Receive Input, Positive
18	20		TPI-	I/O	Twisted Pair Receive Input, Negative.
22	24		nLEDA	OD24	PHY LED Output
23	25		nLEDB	OD24	PHY LED Output

Note 5-1 If the EEPROM is enabled.

6.0 SIGNAL DESCRIPTION PARAMETERS

This section provides a detailed description of each Microchip LAN91C111 signal. The signals are arranged in functional groups according to their associated function.

The 'n' symbol at the beginning of a signal name indicates that it is an active low signal. When 'n' is not present before the signal name, it indicates an active high signal.

The term "assert" or "assertion" indicates that a signal is active; independent of whether that level is represented by a high or low voltage. The term negates or negation indicates that a signal is inactive.

The term High-Z means tri-stated.

The term Undefined means the signal could be high, low, tri-stated, or in some in-between level.

6.1 Buffer Types

O4	Output buffer with 2mA source and 4mA sink
O12	Output buffer with 6mA source and 12mA sink
O16	Output buffer with 8mA source and 16mA sink
O24	Output buffer with 12mA source and 24mA sink
OD16	Open drain buffer with 16mA sink
OD24	Open drain buffer with 24mA sink
I/O4	Bidirectional buffer with 2mA source and 4mA sink
I/O24	Bidirectional buffer with 12mA source and 24mA sink
I/OD	Bidirectional Open drain buffer with 4mA sink
I	Input buffer
IS	Input buffer with Schmitt Trigger Hysteresis
Iclk	Clock input buffer
I/O	Differential Input
O/I	Differential Output
**	5V tolerant. Input pins are able to accept 5V signals

DC levels and conditions defined in the DC Electrical Characteristics section.

LAN91C111

7.0 FUNCTIONAL DESCRIPTION

7.1 Clock Generator Block

1. The XTAL1 and XTAL2 pins are to be connected to a 25 MHz crystal.
2. TX25 is an input clock. It will be the nibble rate of the particular PHY connected to the MII (2.5 MHz for a 10 Mbps PHY, and 25 MHz for a 100 Mbps PHY).
3. RX25 - This is the MII nibble rate receive clock used for sampling received data nibbles and running the receive state machine. (2.5 MHz for a 10 Mbps PHY, and 25 MHz for a 100 Mbps PHY).
4. LCLK - Bus clock - Used by the BIU for synchronous accesses. Maximum frequency is 50 MHz for VL BUS mode, and 8.33 MHz for EISA slave DMA.

7.2 CSMA/CD Block

This is a 16 bit oriented block, with fully- independent Transmit and Receive logic. The data path in and out of the block consists of two 16-bit wide uni-directional FIFOs interfacing the DMA block. The DMA port of the FIFO stores 32 bits to exploit the 32 bit data path into memory, but the FIFOs themselves are 16 bit wide. The Control Path consists of a set of registers interfaced to the CPU via the BIU.

7.2.1 DMA BLOCK

This block accesses packet memory on the CSMA/CD's behalf, fetching transmit data and storing received data. It interfaces the CSMA/CD Transmit and Receive FIFOs on one side and the Arbiter block on the other. To increase the bandwidth into memory, a 50 MHz clock is used by the DMA block, and the data path is 32 bits wide.

For example, during active reception at 100 Mbps, the CSMA/CD block will write a word into the Receive FIFO every 160ns. The DMA will read the FIFO and accumulate two words on the output port to request a memory cycle from the Arbiter every 320ns.

The DMA machine is able to support full duplex operation. Independent receive and transmit counters are used. Transmit and receive cycles are alternated when simultaneous receive and transmit accesses are needed.

7.2.2 ARBITER BLOCK

The Arbiter block sequences accesses to packet RAM requested by the BIU and by the DMA blocks. BIU requests represent pipelined CPU accesses to the Data Register, while DMA requests represent CSMA/CD data movement.

Internal SRAM read accesses are always 32 bit wide, and the Arbiter steers the appropriate byte(s) to the appropriate lanes as a function of the address.

The CPU Data Path consists of two uni-directional FIFOs mapped at the Data Register location. These FIFOs can be accessed in any combination of bytes, word, or doublewords. The Arbiter will indicate 'Not Ready' whenever a cycle is initiated that cannot be satisfied by the present state of the FIFO.

7.3 MMU Block

The Hardware Memory Management Unit allocates memory and transmit and receive packet queues. It also determines the value of the transmit and receive interrupts as a function of the queues. The page size is 2048 bytes, with a maximum memory size of 8kbytes. MIR values are interpreted in 2048 byte units.

7.4 BIU Block

The Bus Interface Unit can handle synchronous as well as asynchronous buses; different signals are used for each one. Transparent latches are added on the address path using rising nADS for latching.

When working with an asynchronous bus like ISA, the read and write operations are controlled by the edges of nRD and nWR. ARDY is used for notifying the system that it should extend the access cycle. The leading edge of ARDY is generated by the leading edge of nRD or nWR while the trailing edge of ARDY is controlled by the internal LAN91C111 clock and, therefore, asynchronous to the bus.

In the synchronous VL Bus type mode, nCYCLE and LCLK are used to for read and write operations. Completion of the cycle may be determined by using nSRDY. nSRDY is controlled by LCLK and synchronous to the bus.

Direct 32 bit access to the Data Path is supported by using the nDATACS input. By asserting nDATACS, external DMA type of devices will bypass the BIU address decoders and can sequentially access memory with no CPU intervention. nDATACS accesses can be used in the EISA DMA burst mode (nVLBUS=1) or in asynchronous cycles. These cycles MUST be 32 bit cycles. Please refer to the corresponding timing diagrams for details on these cycles.

The BIU is implemented using the following principles:

- a) Address decoding is based on the values of A15-A4 and AEN.
- b) Address latching is performed by using transparent latches that are transparent when nADS=0 and nRD=1, nWR=1 and latch on nADS rising edge.
- c) Byte, word and doubleword accesses to all registers and Data Path are supported except a doubleword write to offset Ch will only write the BANK SELECT REGISTER (offset 0x0Fh).
- d) No bus byte swapping is implemented (no eight bit mode).
- e) Word swapping as a function of A1 is implemented for 16 bit bus support.
- f) The asynchronous interface uses nRD and nWR strobes. If necessary, ARDY is negated on the leading edge of the strobe. The ARDY trailing edge is controlled by CLK.
- g) The VLBUS synchronous interface uses LCLK, nADS, and W/nR as defined in the VESA specification as well as nCYCLE to control read and write operations and generate nSRDY.
- h) EISA burst DMA cycles to and from the DATA REGISTER are supported as defined in the EISA Slave Mode "C" specification when nDATACS is driven by nDAK.
- i) Synchronous and asynchronous cycles can be mixed as long as they are not active simultaneously.
- j) Address and bank selection can be bypassed to generate 32 bit Data Path accesses by activating the nDATACS pin.

7.5 MAC-PHY Interface

The LAN91C111 integrates the IEEE 802.3 Physical Layer (PHY) and Media Access Control (MAC) into the same silicon. The data path connection between the MAC and the internal PHY is provided by the internal MII. The LAN91C111 also supports the EXT_PHY mode for the use of an external PHY, such as HPNA. This mode isolates the internal PHY to allow interface with an external PHY through the MII pins. To enter this mode, set EXT PHY bit to 1 in the Configuration Register.

7.5.1 MANAGEMENT DATA SOFTWARE IMPLEMENTATION

The MII interface contains of a pair of signals that physically transport the management information across the MII, a frame format and a protocol specification for exchanging management frames, and a register set that can be read and written using these frames. MII management refers to the ability of a management entity to communicate with PHY via the MII serial management interface (MI) for the purpose of displaying, selecting and/or controlling different PHY options. The host manipulates the MAC to drive the MII management serial interface. By manipulating the MAC's registers, MII management frames are generated on the management interface for reading or writing information from the PHY registers. Timing and framing for each management command is to be generated by the CPU (host).

The MAC and external PHY communicate via MDIO and MDC of the MII Management serial interface.

MDIO: Management Data input/output. Bi-directional between MAC and PHY that carries management data. All control and status information sent over this pin is driven and sampled synchronously to the rising edge of MDC signal.

MDC: Management Data Clock. Sourced by the MAC as a timing reference for transfer of information on the MDIO signal. MDC is a periodic signal with no maximum high or low times. The minimum high and low times should be 160ns each and the minimum period of the signal should be 400ns. These values are regardless of the nominal period of the TX and RX clocks.

7.5.2 MANAGEMENT DATA TIMING

A timing diagram for a MI serial port frame is shown in [Figure 7-1](#). The MI serial port is idle when at least 32 continuous 1's are detected on MDIO and remains idle as long as continuous 1's are detected. During idle, MDIO is in the high impedance state. When the MI serial port is in the idle state, a 01 pattern on the MDIO initiates a serial shift cycle. Data on MDIO is then shifted in on the next 14 rising edges of MDC (MDIO is high impedance). If the register access mode is not enabled, on the next 16 rising edges of MDC, data is either shifted in or out on MDIO, depending on whether a write or read cycle was selected with the bits READ and WRITE. After the 32 MDC cycles have been completed, one

LAN91C111

complete register has been read/written, the serial shift process is halted, data is latched into the device, and MDIO goes into high impedance state. Another serial shift cycle cannot be initiated until the idle condition (at least 32 continuous 1's) is detected.

7.5.3 MI SERIAL PORT FRAME STRUCTURE

The structure of the PHY serial port frame is shown in [Table 9-1](#) and timing diagram of a frame is shown in [Figure 7-1](#). Each serial port access cycle consists of 32 bits (or 192 bits if multiple register access is enabled and REGAD[4:0]=11111), exclusive of idle. The first 16 bits of the serial port cycle are always write bits and are used for addressing. The last 16/176 bits are from one/all of the 11 data registers.

The first 2 bit in [Table 9-1](#) and [Figure 7-1](#) are start bits and need to be written as a 01 for the serial port cycle to continue. The next 2 bits are a read and write bit which determine if the accessed data register bits will be read or write. The next 5 bits are device addresses. The next 5 bits are register address select bits, which select one of the five data registers for access. The next 1 bit is a turnaround bit which is not an actual register bit but extra time to switch MDIO from write to read if necessary, as shown in [Figure 7-1](#). The final 16 bits of the PHY MI serial port cycle (or 176 bits if multiple register access is enabled and REGAD[4:0]=11111) come from the specific data register designated by the register address bits REGAD[4:0].

FIGURE 7-1: MI SERIAL PORT FRAME TIMING DIAGRAM

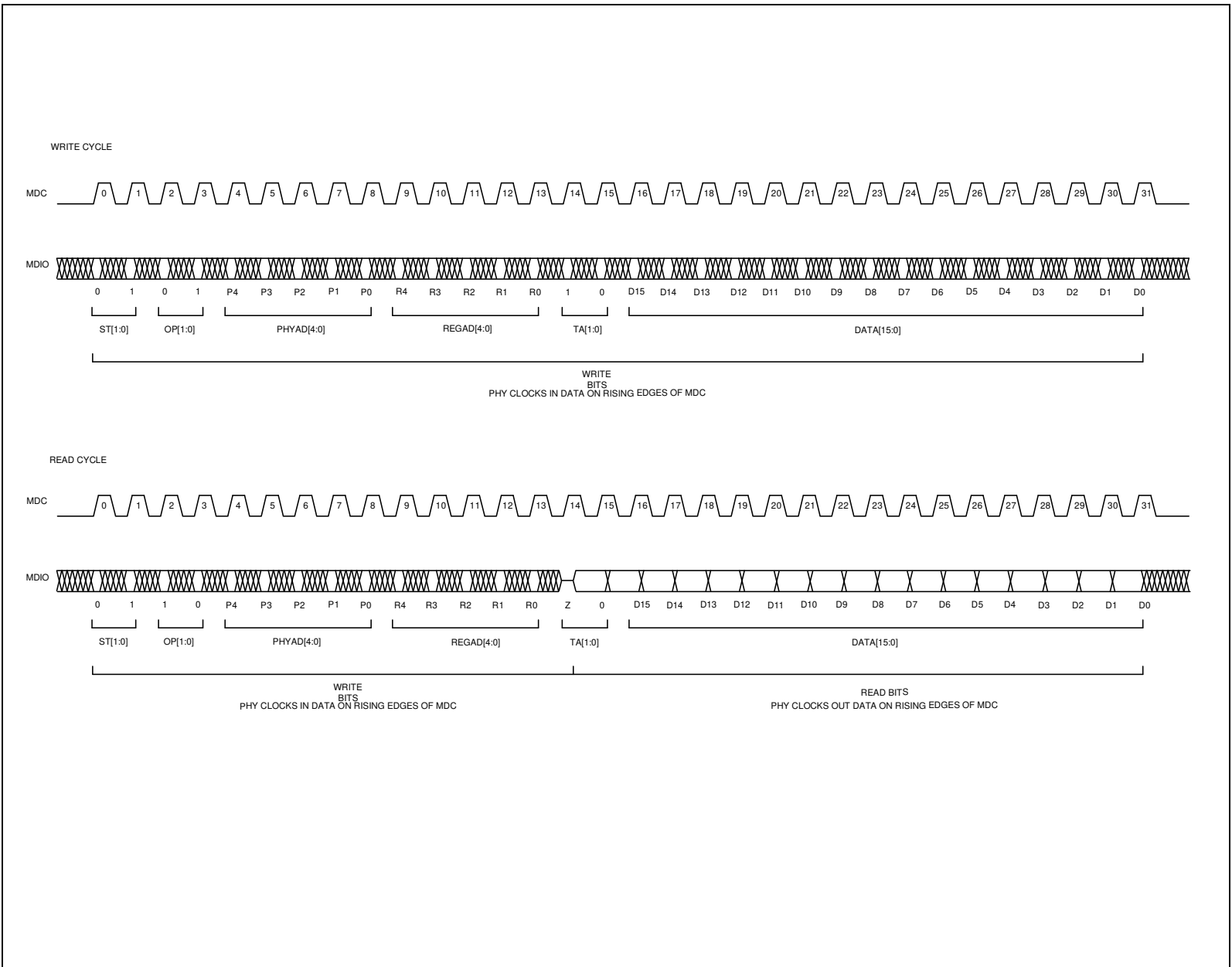

RXD0-RXD3 should always be aligned to packet nibbles, therefore, opening flag detection does not consider misaligned cases. Opening flag detection expects the 5Dh pattern and will not reject the packet on non-preamble patterns.

CRS100 is used as a frame envelope signal for the CSMA/CD MAC state machines (deferral and backoff functions), but it is not used for receive framing functions. CRS100 is an asynchronous signal and it will be active whenever there is activity on the cable, including LAN91C111 transmissions and collisions.

7.6 Serial EEPROM Interface

This block is responsible for reading the serial EEPROM upon hardware reset (or equivalent command) and defining defaults for some key registers. A write operation is also implemented by this block, that under CPU command will program specific locations in the EEPROM. This block is an autonomous state machine and controls the internal Data Bus of the LAN91C111 during active operation.

7.7 Internal Physical Layer

The LAN91C111 integrates the IEEE 802.3 physical layer (PHY) internally. The EXT PHY bit in the Configuration Register is 0 as the default configuration to set the internal PHY enabled. The internal PHY address is 00000, the driver must use this address to talk to the internal PHY. *The internal PHY is placed in isolation mode at power up and reset. It can be removed from isolation mode by clearing the MII_DIS bit in the PHY Control Register. If necessary, the internal PHY can be enabled by clearing the EXT_PHY bit in the Configuration Register.*

The internal PHY of LAN91C111 has nine main sections: controller interface, encoder, decoder, scrambler, descrambler, clock and data recovery, twisted pair transmitter, twisted pair receiver, and MI serial port.

The LAN91C111 can operate as a 100BASE-TX device (hereafter referred to as 100Mbps mode) or as a 10BASE-T device (hereafter referred to as 10Mbps mode). The difference between the 100Mbps mode and the 10Mbps mode is data rate, signaling protocol, and allowed wiring. The 100Mbps TX mode uses two pairs of category 5 or better UTP or STP twisted pair cable with 4B5B encoded, scrambled, and MLT-3 coded 62.5 MHz ternary data to achieve a throughput of 100Mbps. The 10Mbps mode uses two pairs of category 3 or better UTP or STP twisted pair cable with Manchester encoded, 10MHz binary data to achieve a 10Mbps throughput. The data symbol format on the twisted pair cable for the 100 and 10Mbps modes are defined in IEEE 802.3 specifications and shown in [Figure 7-3](#).

LAN91C111

FIGURE 7-3: TX/10BT FRAME FORMAT

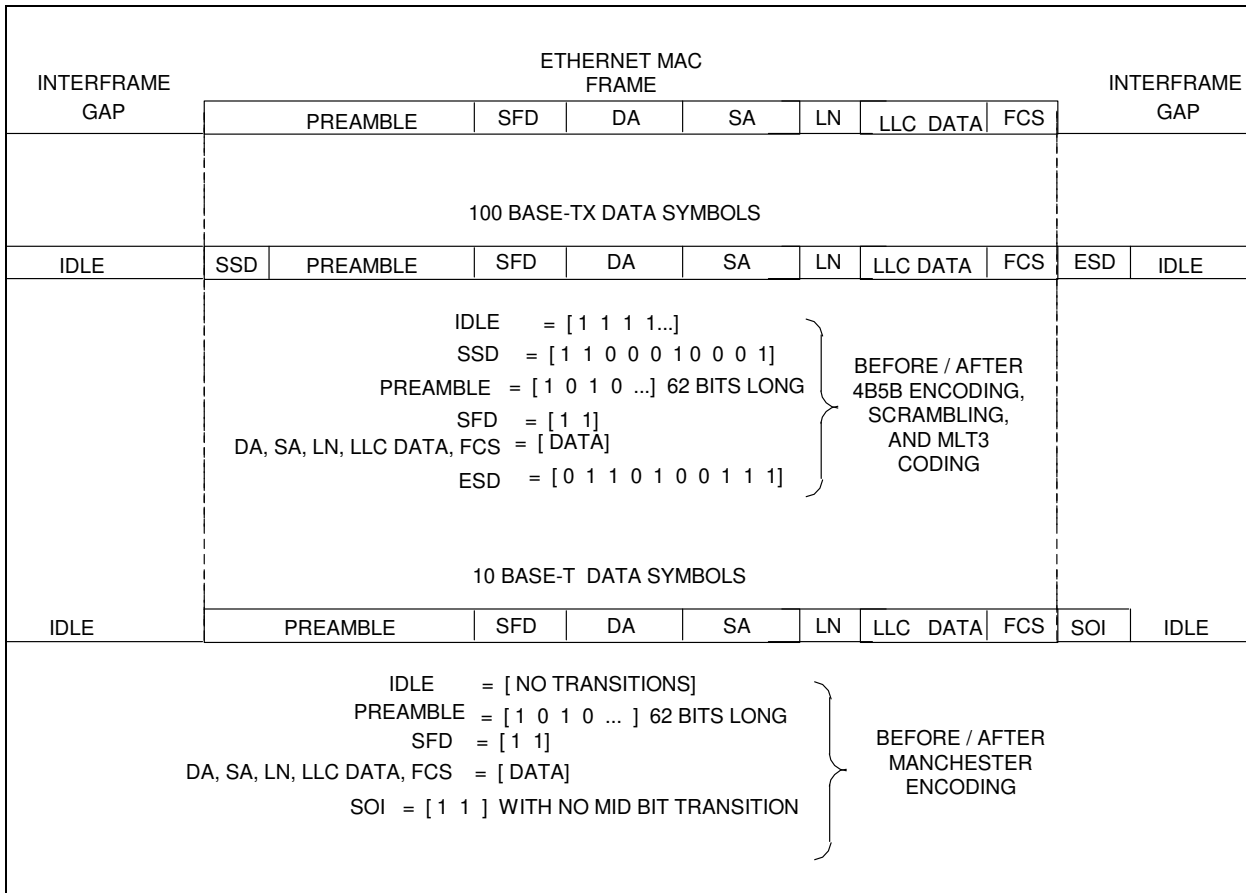

On the transmit side for 100Mbps TX operation, data is received on the controller and then sent to the 4B5B encoder for formatting. The encoded data is then sent to the scrambler. The scrambled and encoded data is then sent to the TP transmitter. The TP transmitter converts the encoded and scrambled data into MLT-3 ternary format, reshapes the output, and drives the twisted pair cable.

On the receive side for 100Mbps TX operation, the twisted pair receiver receives incoming encoded and scrambled MLT-3 data from the twisted pair cable, remove any high frequency noise, equalizes the input signal to compensate for the effects of the cable, qualifies the data with a squelch algorithm, and converts the data from MLT-3 coded twisted pair levels to internal digital levels. The output of the twisted pair receiver then goes to a clock and data recovery block which recovers a clock from the incoming data, uses the clock to latch in valid data into the device, and converts the data back to NRZ format. The NRZ data is then unscrambled and decoded by the 4B5B decoder and descrambler, respectively, and outputted to the Ethernet controller.

10Mbps operation is similar to the 100Mbps TX operation except, (1) there is no scrambler/descrambler, (2) the encoder/decoder is Manchester instead of 4B5B, (3) the data rate is 10Mbps instead of 100Mbps, and (4) the twisted pair symbol data is two level Manchester instead of ternary MLT-3.

The Management Interface, (hereafter referred to as the MI serial port), is a two pin bi-directional link through which configuration inputs can be set and status outputs can be read. Each block plus the operating modes are described in more detail in the following sections.

7.7.1 MII DISABLE

The internal PHY MII interface can be disabled by setting the MII disable bit in the MI serial port Control register. When the MII is disabled, the MII inputs are ignored, the MII outputs are placed in high impedance state, and the TP output is high impedance.

7.7.2 ENCODER

7.7.2.1 4B5B Encoder - 100 Mbps

100BASE-TX requires that the data be 4B5B encoded. 4B5B coding converts the 4-Bit data nibbles into 5-Bit data code words. The mapping of the 4B nibbles to the 5B code words is specified in IEEE 802.3. The 4B5B encoder on the LAN91C111 takes 4B nibbles from the controller interface, converts them into 5B words and sends the 5B words to the scrambler. The 4B5B encoder also substitutes the first 8 bits of the preamble with the SSD delimiters (a.k.a. /J/K/ symbols) and adds an ESD delimiter (a.k.a. MR/ symbols) to the end of every packet, as defined in IEEE 802.3. The 4B5B encoder also fills the period between packets, called the idle period, with the continuous stream of idle symbols.

7.7.2.2 Manchester Encoder - 10 Mbps

The Manchester encoding process combines clock and NRZ data such that the first half of the data bit contains the complement of the data, and the second half of the data bit contains the true data, as specified in IEEE 802.3. This ensures that a transition always occurs in the middle of the bit call. The Manchester encoder on the LAN91C111 converts the 10Mbps NRZ data from the controller interface into a Manchester Encoded data stream for the TP transmitter and adds a start of idle pulse (SOI) at the end of the packet as specified in IEEE 802.3. The Manchester encoding process is only done on actual packet data, and the idle period between packets is not Manchester encoded and filled with link pulses.

7.7.3 DECODER

7.7.3.1 4B5B Decoder - 100 Mbps

Since the TP input data is 4B5B encoded on the transmit side, it must also be decoded by the 4B5B decoder on the receive side. The mapping of the 5B nibbles to the 4B code words is specified in IEEE 802.3. The 4B5B decoder on the LAN91C111 takes the 5B code words from the descrambler, converts them into 4B nibbles per Table 2, and sends the 4B nibbles to the controller interface. The 4B5B decoder also strips off the SSD delimiter (a.k.a. /J/K/ symbols) and replaces them with two 4B Data 5 nibbles (a.k.a. /5/ symbol), and strips off the ESD delimiter (a.k.a. /T/R/ symbols) and replaces it with two 4B Data 0 nibbles (a.k.a. /I/symbol), per IEEE 802.3 specifications and shown in [Figure 7-3](#).

TABLE 7-1: 4B/5B SYMBOL MAPPING

Symbol Name	Description	5B Code	4B Code
0	Data 0	11110	0000
1	Data 1	01001	0001
2	Data 2	10100	0010
3	Data 3	10101	0011
4	Data 4	01010	0100
5	Data 5	01011	0101
6	Data 6	01110	0110
7	Data 7	01111	0111
8	Data 8	10010	1000
9	Data 9	10011	1001
A	Data A	10110	1010
B	Data B	10111	1011
C	Data C	11010	1100
D	Data D	11011	1101
E	Data E	11100	1110

LAN91C111

TABLE 7-1: 4B/5B SYMBOL MAPPING (CONTINUED)

Symbol Name	Description	5B Code	4B Code
F	Data F	11101	1111
I	Idle	11111	0000
J	SSD #1	11000	0101
K	SSD #2	10001	0101
T	ESD #1	01101	0000
R	ESD #2	00111	0000
H	Halt	00100	Undefined
---	Invalid codes	All others*	0000*

* These 5B codes are not used. For decoder, these 5B codes are decoded to 4B 0000. For encoder, 4B 0000 is encoded to 5B 11110, as shown in symbol Data 0.

The 4B5B decoder detects SSD, ESD and codeword errors in the incoming data stream as specified in IEEE 802.3. These errors are indicated by asserting RX_ER output while the errors are being transmitted across RXD[3:0], and they are also indicated in the serial port by setting SSD, ESD, and codeword error bits in the PHY MI serial port Status Output register.

7.7.3.2 Manchester Decoder - 10 Mbps

In Manchester coded data, the first half of the data bit contains the complement of the data, and the second half of the data bit contains the true data. The Manchester decoder in the LAN91C111 converts the Manchester encoded data stream from the TP receiver into NRZ data for the controller interface by decoding the data and stripping off the SOI pulse. Since the clock and data recovery block has already separated the clock and data from the TP receiver, the Manchester decoding process to NRZ data is inherently performed by that block.

7.7.4 CLOCK AND DATA RECOVERY

7.7.4.1 Clock Recovery - 100 Mbps

Clock recovery is done with a PLL. If there is no valid data present on the TP inputs, the PLL is locked to the 25 MHz TX25. When valid data is detected on the TP inputs with the squelch circuit and when the adaptive equalizer has settled, the PLL input is switched to the incoming data on the TP input. The PLL then recovers a clock by locking onto the transitions of the incoming signal from the twisted pair wire. The recovered clock frequency is a 25 MHz nibble clock, and that clock is outputted on the controller interface signal RX25.

7.7.4.2 Data Recovery - 100 Mbps

Data recovery is performed by latching in data from the TP receiver with the recovered clock extracted by the PLL. The data is then converted from a single bit stream into nibble wide data word according to the format shown in [Figure 7-2](#).

7.7.4.3 Clock Recovery - 10 Mbps

The clock recovery process for 10Mbps mode is identical to the 100Mbps mode except, (1) the recovered clock frequency is 2.5 MHz nibble clock, (2) the PLL is switched from TX25 to the TP input when the squelch indicates valid data, (3) The PLL takes up to 12 transitions (bit times) to lock onto the preamble, so some of the preamble data symbols are lost, but the clock recovery block recovers enough preamble symbols to pass at least 6 nibbles of preamble to the receive controller interface as shown in [Figure 7-2](#).

7.7.4.4 Data Recovery - 10 Mbps

The data recovery process for 10Mbps mode is identical to the 100Mbps mode. As mentioned in the Manchester Decoder section, the data recovery process inherently performs decoding of Manchester encoded data from the TP inputs.

7.7.5 SCRAMBLER

7.7.5.1 100 Mbps

100BASE-TX requires scrambling to reduce the radiated emissions on the twisted pair. The LAN91C111 scrambler takes the encoded data from the 4B5B encoder, scrambles it per the IEEE 802.3 specifications, and sends it to the TP transmitter.

7.7.5.2 10 Mbps

A scrambler is not used in 10Mbps mode.

7.7.5.3 Scrambler Bypass

The scrambler can be bypassed by setting the bypass scrambler/descrambler bit in the PHY MI serial port Configuration 1 register. When this bit is set, the 5B data bypasses the scrambler and goes directly from the 4B5B encoder to the twisted pair transmitter.

7.7.6 DESCRAMBLER

7.7.6.1 100 Mbps

The LAN91C111 descrambler takes the scrambled data from the data recovery block, descrambles it per the IEEE 802.3 specifications, aligns the data on the correct 5B word boundaries, and sends it to the 4B5B decoder.

The algorithm for synchronization of the descrambler is the same as the algorithm outlined in the IEEE 802.3 specification. Once the descrambler is synchronized, it will maintain synchronization as long as enough descrambled idle pattern 1's are detected within a given interval. To stay in synchronization, the descrambler needs to detect at least 25 consecutive descrambled idle pattern 1's in a 1ms interval. If 25 consecutive descrambled idle pattern 1's are not detected within the 1ms interval, the descrambler goes out of synchronization and restarts the synchronization process.

If the descrambler is in the unsynchronized state, the descrambler loss of synchronization detect bit is set in the MI serial port Status Output register to indicate this condition. Once this bit is set, it will stay set until the descrambler achieves synchronization.

7.7.6.2 10 Mbps

A descrambler is not used in 10 Mbps mode.

7.7.6.3 Descrambler Bypass

The descrambler can be bypassed by setting the bypass scrambler/descrambler bit in the PHY MI serial port Configuration 1 register. When this bit is set, the data bypasses the descrambler and goes directly from the TP receiver to the 4B5B decoder.

7.7.7 TWISTED PAIR TRANSMITTER

7.7.7.1 Transmitter - 100 Mbps

The TX transmitter consists of MLT-3 encoder, waveform generator and line driver.

The MLT-3 encoder converts the NRZ data from the scrambler into a three level MLT-3 code required by IEEE 802.3. MLT-3 coding uses three levels and converts 1's to transitions between the three levels, and converts 0's to no transitions or changes in level.

The purpose of the waveform generator is to shape the transmit output pulse. The waveform generator takes the MLT-3 three level encoded waveform and uses an array of switched current sources to control the rise/fall time and level of the signal at the Output. The output of the switched current sources then goes through a low pass filter in order to "smooth" the current output and remove any high frequency components. In this way, the waveform generator pre-shapes the output waveform transmitted onto the twisted pair cable to meet the pulse template requirements outlined in IEEE 802.3. The waveform generator eliminates the need for any external filters on the TP transmit output.

The line driver converts the shaped and smoothed waveform to a current output that can drive 100 meters of category 5 unshielded twisted pair cable or 150 Ohm shielded twisted pair cable.