



Chipsmall Limited consists of a professional team with an average of over 10 year of expertise in the distribution of electronic components. Based in Hongkong, we have already established firm and mutual-benefit business relationships with customers from,Europe,America and south Asia,supplying obsolete and hard-to-find components to meet their specific needs.

With the principle of "Quality Parts,Customers Priority,Honest Operation,and Considerate Service",our business mainly focus on the distribution of electronic components. Line cards we deal with include Microchip,ALPS,ROHM,Xilinx,Pulse,ON,Everlight and Freescale. Main products comprise IC,Modules,Potentiometer,IC Socket,Relay,Connector.Our parts cover such applications as commercial,industrial, and automotives areas.

We are looking forward to setting up business relationship with you and hope to provide you with the best service and solution. Let us make a better world for our industry!



Contact us

Tel: +86-755-8981 8866 Fax: +86-755-8427 6832

Email & Skype: info@chipsmall.com Web: www.chipsmall.com

Address: A1208, Overseas Decoration Building, #122 Zhenhua RD., Futian, Shenzhen, China



▲ Parts List

ITEM	QTY	PART NUMBER	DESCRIPTION
1	1	F060601	LAPPLU10
3	1	F051706	35MM FLUSH MOUNT BEZEL
4	1	F051707	35MM FLUSH MOUNT RETAINER
2	1	F060212	29MM GRN LENS
5	1	F050422	LED 24VDC GRN

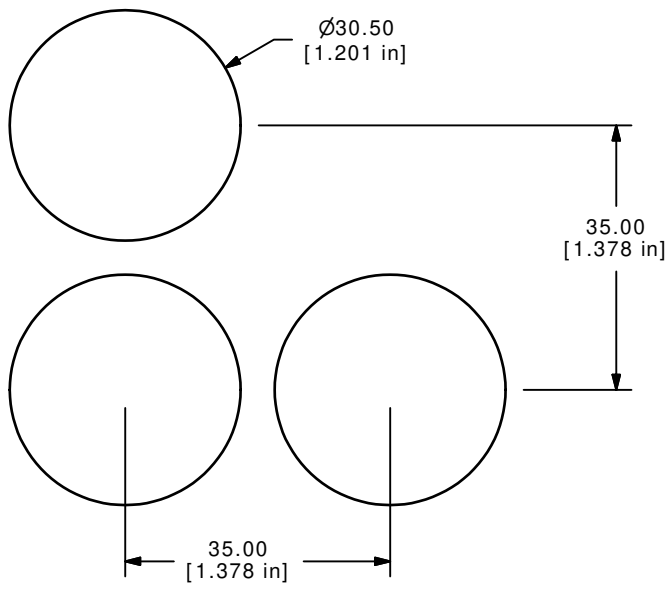

RECOMMEND PANEL MOUNTING

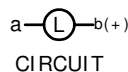

NOTES:

1. ALL DIMENSIONS IN MM [INCH].
2. GENERAL TOLERANCE: 0.0 ± 0.4
0.00 ± 0.25
3. TERM. NOS. FOR REF. ONLY.
4. RATING: 5A @250VAC
8A @125VAC
.2A @250VDC
6A @24VDC
5. INSULATION: 1,000 MΩ MIN.
6. DIELECTRIC STRENGTH: 2000V FOR 1 MIN.
7. SEALED TO IP65.
8. TRAVEL: 3.0MM FULL TRAVEL, 2.0MM LATCH
9. ELECTRICAL LIFE: > 50,000 CYCLES
10. OPERATING TEMP: -25C TO +55C
11. PANEL THICKNESS: 0.5MM TO 3.0MM
12. LAMP VOLTAGE: LED, 24VDC, GREEN
13. ▲ DENOTES CRITICAL PARAMETER.
14. 2002/95/EC (ROHS) COMPLIANT

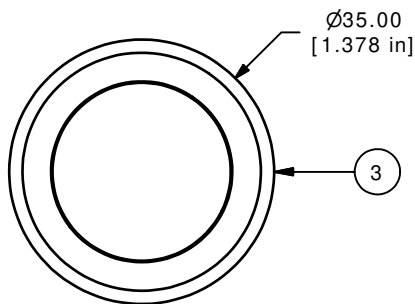

ISOMETRIC

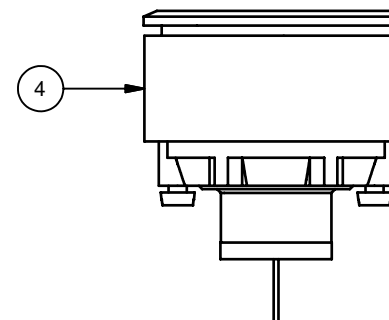
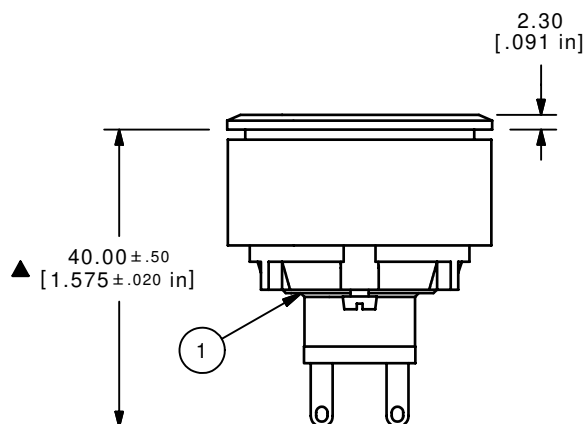

TITLE LAPPLU30KGRNGRN

A	16826	RELEASED FOR PRODUCTION	1/10/07	TN
REV	PCR NO	DESCRIPTION	DATE	BY

THE INFORMATION CONTAINED IN THIS DOCUMENT IS PROPRIETARY TO E-SWITCH AND IS NOT TO BE COPIED OR TRANSFERRED

SCALE	DATE	DR	DWG	REV
1	1/10/2007	TN	XF0706P	A