



Chipsmall Limited consists of a professional team with an average of over 10 year of expertise in the distribution of electronic components. Based in Hongkong, we have already established firm and mutual-benefit business relationships with customers from,Europe,America and south Asia,supplying obsolete and hard-to-find components to meet their specific needs.

With the principle of "Quality Parts,Customers Priority,Honest Operation,and Considerate Service",our business mainly focus on the distribution of electronic components. Line cards we deal with include Microchip,ALPS,ROHM,Xilinx,Pulse,ON,Everlight and Freescale. Main products comprise IC,Modules,Potentiometer,IC Socket,Relay,Connector.Our parts cover such applications as commercial,industrial, and automotives areas.

We are looking forward to setting up business relationship with you and hope to provide you with the best service and solution. Let us make a better world for our industry!



## Contact us

Tel: +86-755-8981 8866 Fax: +86-755-8427 6832

Email & Skype: info@chipsmall.com Web: www.chipsmall.com

Address: A1208, Overseas Decoration Building, #122 Zhenhua RD., Futian, Shenzhen, China



# LB11967V

---

## Single-Phase Full-Wave Pre-Driver for Variable Speed Fan Motor

### Overview

The LB11967V is a single-phase bipolar variable speed fan motor pre-driver that works with an external PWM signal.

A highly efficient, quiet and low power consumption motor driver circuit, with a large variable speed, can be implemented by adding a small number of external components.

This device is optimal for driving large scale fan motors (with large air volume and large current) such as those used in servers and consumer products.

### Functions

- Pre-driver for single-phase full-wave drive  
PNP-EMOS is used as an external power Transistor, enabling high-efficiency low-consumption drive by means of the low-saturation output and single-phase full-wave drive. (PMOS-NMOS also applicable)
- External PWM input enabling variable speed control  
Separately-excited upper direct PWM ( $f = 25\text{kHz}$ ) control method, enabling highly silent speed control
- Compatible with 12V, 24V, and 48V power supplies
- Current limiter circuit incorporated  
Chopper type current limit at start
- Reactive current cut circuit incorporated  
Reactive current before phase change is cut to enable silent and low-consumption drive.
- Minimum speed setting pin  
Minimum speed can be set with external resistor. The start assistance circuit enables start at extremely low speed.
- Constant-voltage output pin for Hall bias
- Lock protection and automatic reset functions incorporated
- (Rotation speed detection), RD (Lock detection) output

### Applications

- Computing & Peripherals
- Consumer
- Server



**ON Semiconductor®**

[www.onsemi.com](http://www.onsemi.com)

---

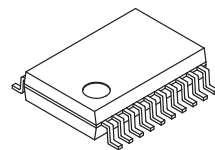

SSOP20 (225mil)

---

### GENERIC MARKING DIAGRAM\*

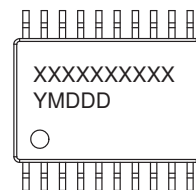

XXXXX = Specific Device Code

Y = Year

M = Month

DDD = Additional Traceability Data

---

### ORDERING INFORMATION

See detailed ordering and shipping information on page 10 of this data sheet.

# LB11967V

## Specifications

### Maximum Ratings at Ta = 25°C (Note1)

Parameter	Symbol	Conditions	Ratings	Unit
V <sub>CC</sub> maximum supply voltage	V <sub>CC</sub> max		18	V
OUT pin maximum output current	I <sub>OUT</sub> max		50	mA
OUT pin output withstand voltage	V <sub>OUT</sub> max		18	V
HB maximum output current	I <sub>HB</sub> max		10	mA
VTH input pin withstand voltage	V <sub>VTH</sub> max		8	V
RD/FG output pin output withstand voltage	V <sub>RD/VFG</sub> max		18	V
RD/FG output current	I <sub>RD/IFG</sub> max		10	mA
Allowable power dissipation	Pd max	Mounted on a specified board (Note2)	800	mW
Operating temperature range	Topr		-30 to +95	°C
Storage temperature range	Tstg		-55 to +150	°C

1. Stresses exceeding those listed in the Maximum Rating table may damage the device. If any of these limits are exceeded, device functionality should not be assumed, damage may occur and reliability may be affected.
2. Specified board: 114.3mm × 76.1mm × 1.6mm, glass epoxy board.

### Recommended Operating Conditions at Ta = 25°C (Note3)

Parameter	Symbol	Conditions	Ratings	Unit
V <sub>CC</sub> supply voltage	V <sub>CC</sub>		6 to 16	V
VTH input level voltage range	VTH	Full speed mode	0 to 7	V
Hall input common phase input voltage range	VICM		0.2 to 3	V

3. Functional operation above the stresses listed in the Recommended Operating Ranges is not implied. Extended exposure to stresses beyond the Recommended Operating Ranges limits may affect device reliability.

### Electrical Characteristics at Ta = 25°C, V<sub>CC</sub> = 12V, unless otherwise specified. (Note4)

Parameter	Symbol	Conditions	Ratings			Unit
			min	typ	max	
Circuit current	I <sub>CC1</sub>	During drive	6	10	14	mA
	I <sub>CC2</sub>	During lock protection	6	10	14	mA
6VREG voltage	6VREG	I <sub>6VREG</sub> = 5mA	5.80	6.0	6.15	V
HB voltage	V <sub>HB</sub>	I <sub>HB</sub> = 5mA	1.05	1.22	1.35	V
VOVER voltage	V <sub>VOVER</sub>	I <sub>VOVER</sub> = 1mA	12.0	12.8	13.6	V
CPWM-H level voltage	V <sub>CRH</sub>		4.35	4.55	4.75	V
CPWM-L level voltage	V <sub>CRL</sub>		1.45	1.65	1.85	V
CPWM oscillation frequency	FPWM	C = 100pF	18	25	32	kHz
CT pin H level voltage	V <sub>CTH</sub>		3.4	3.6	3.8	V
CT pin L level voltage	V <sub>CTL</sub>		1.4	1.6	1.8	V
ICT pin charge current	I <sub>CT1</sub>	V <sub>CT</sub> = 1.2V	1.6	2.0	2.5	μA
ICT pin discharge current	I <sub>CT2</sub>	V <sub>CT</sub> = 4.0V	0.16	0.20	0.28	μA
ICT charge/discharge current ratio	R <sub>CT</sub>	I <sub>CT1</sub> /I <sub>CT2</sub>	8	10	12	deg
OUT-N output voltage	V <sub>ON</sub>	I <sub>O</sub> = 20mA	4	10		V
OUT-P sink current	I <sub>OP</sub>		15	20		mA
Hall input sensitivity	V <sub>HN</sub>	Zero peak value (including offset and hysteresis)		10	20	mV
RD/FG output pin L voltage	V <sub>RD/VFG</sub>	I <sub>RD/IFG</sub> = 5mA		0.15	0.3	V
RD/FG output pin leak current	I <sub>RDL/IFGL</sub>	V <sub>RD/VFG</sub> = 16V			30	μA

4. Product parametric performance is indicated in the Electrical Characteristics for the listed test conditions, unless otherwise noted. Product performance may not be indicated by the Electrical Characteristics if operated under different conditions.

# LB11967V

## Package Dimensions

unit : mm

SSOP20 (225mil)

CASE 565AN

ISSUE A

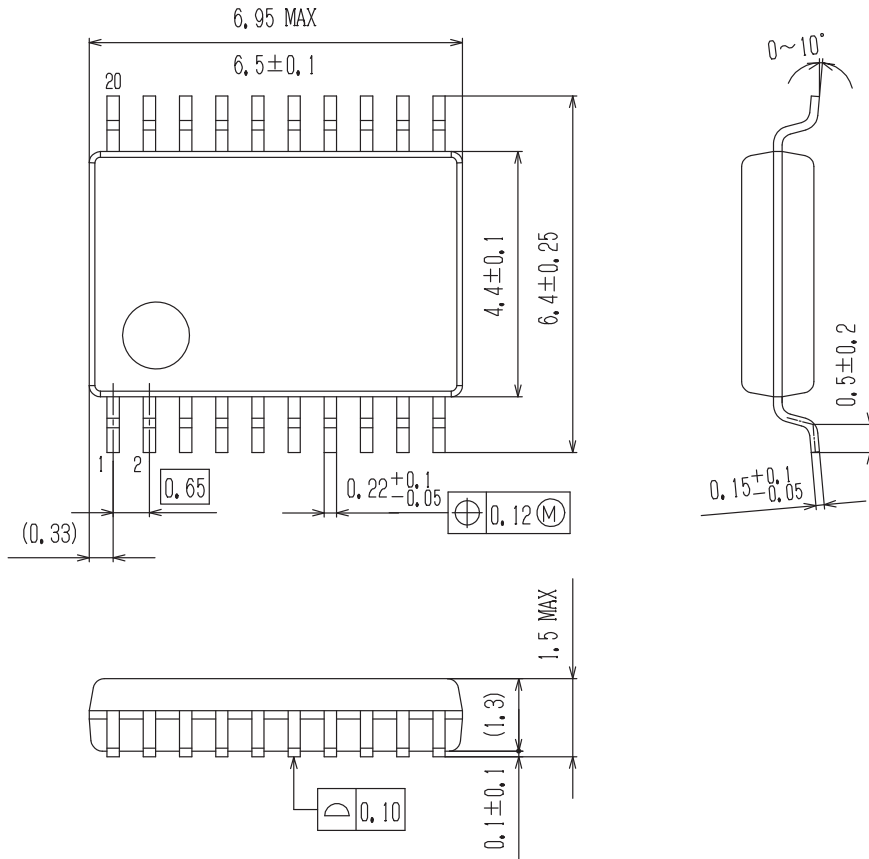

### SOLDERING FOOTPRINT\*

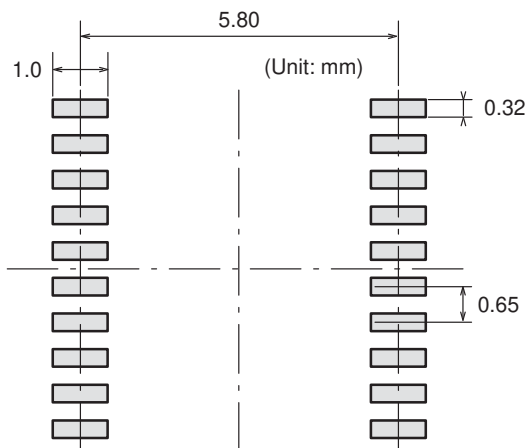

NOTE: The measurements are not to guarantee but for reference only.

\*For additional information on our Pb-Free strategy and soldering details, please download the ON Semiconductor Soldering and Mounting Techniques Reference Manual, SOLDERRM/D.

# LB11967V

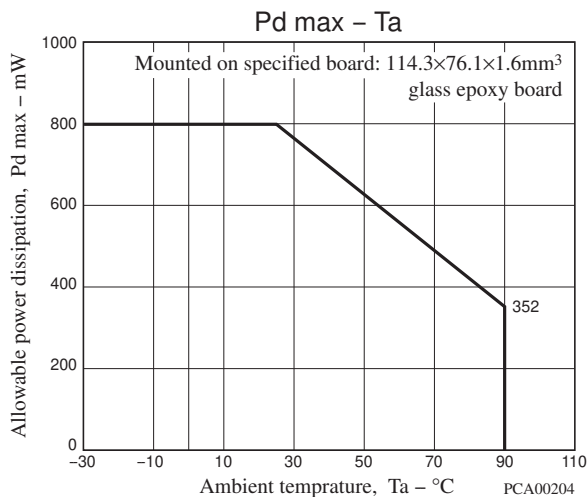

## Pin Assignment

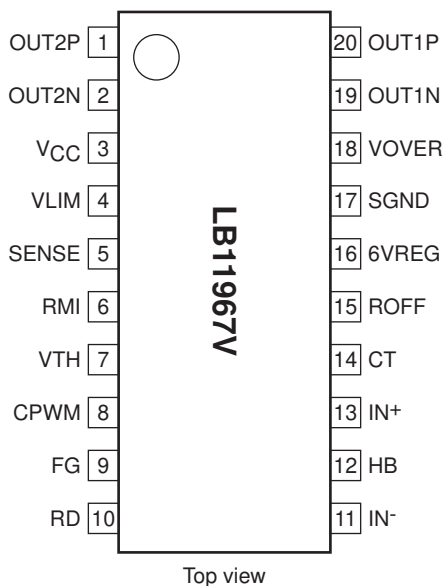

## Truth Table

During full-speed rotation

IN <sup>-</sup>	IN <sup>+</sup>	CT	OUT1P	OUT1N	OUT2P	OUT2N	FG	RD	Mode
H	L	L	L	L	OFF	H	L	L	OUT1 → 2 drive
L	H		OFF	H	L	L	OFF		OUT2 → 1 drive
H	L	H	OFF	L	OFF	H	L	OFF	Lock protection
L	H		OFF	H	OFF	L	OFF		

VTH	CPWM	IN <sup>-</sup>	IN <sup>+</sup>	OUT1P	OUT1N	OUT2P	OUT2N	Mode
L	H	H	L	L	L	OFF	H	OUT1 → 2 drive
		L	H	OFF	H	L	L	OUT2 → 1 drive
H	L	H	L	OFF	L	OFF	H	During rotation Regeneration in lower Tr
		L	H	OFF	H	OFF	L	

# LB11967V

## Block Diagram

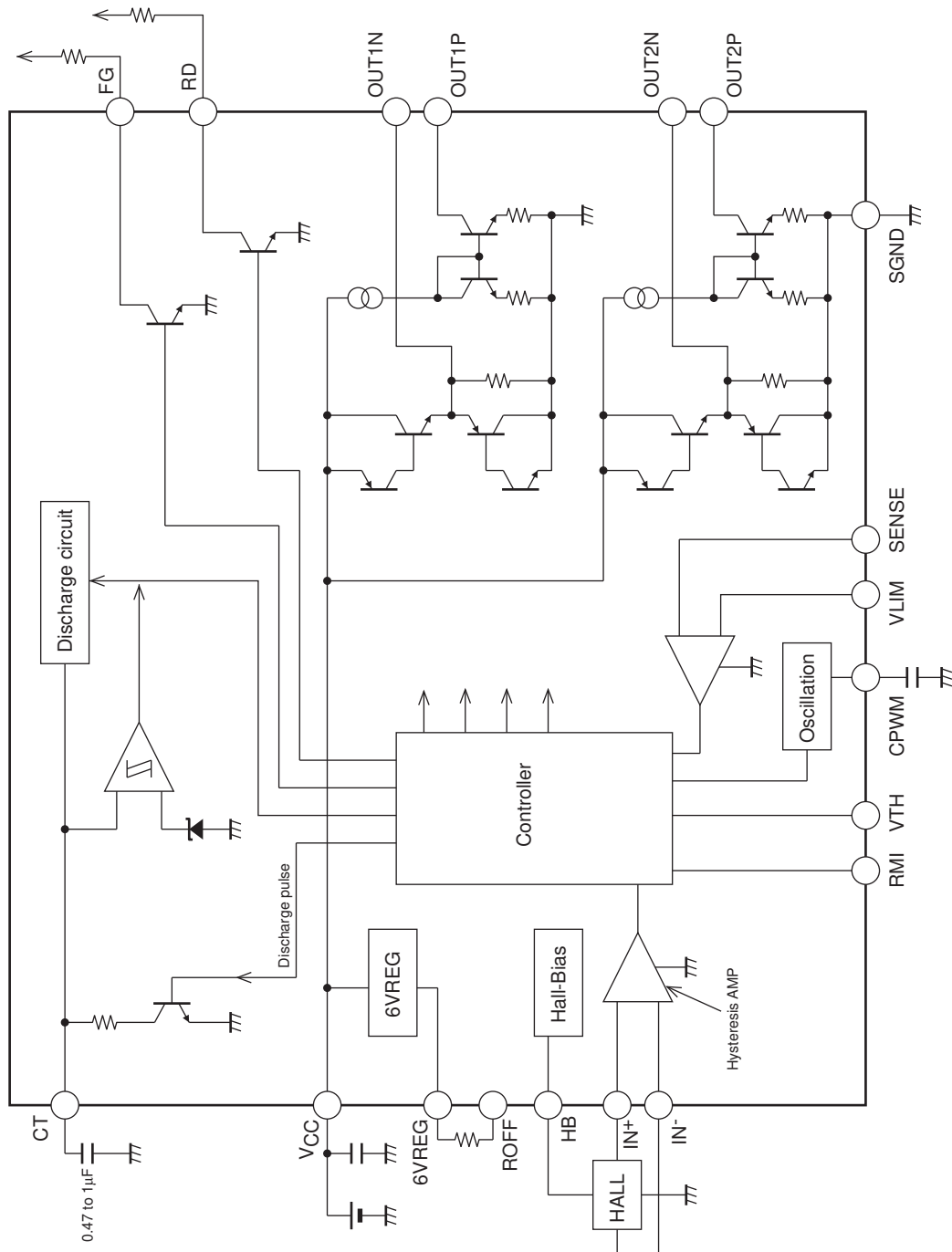

# LB11967V

## Sample Application Circuit 1 (12V)

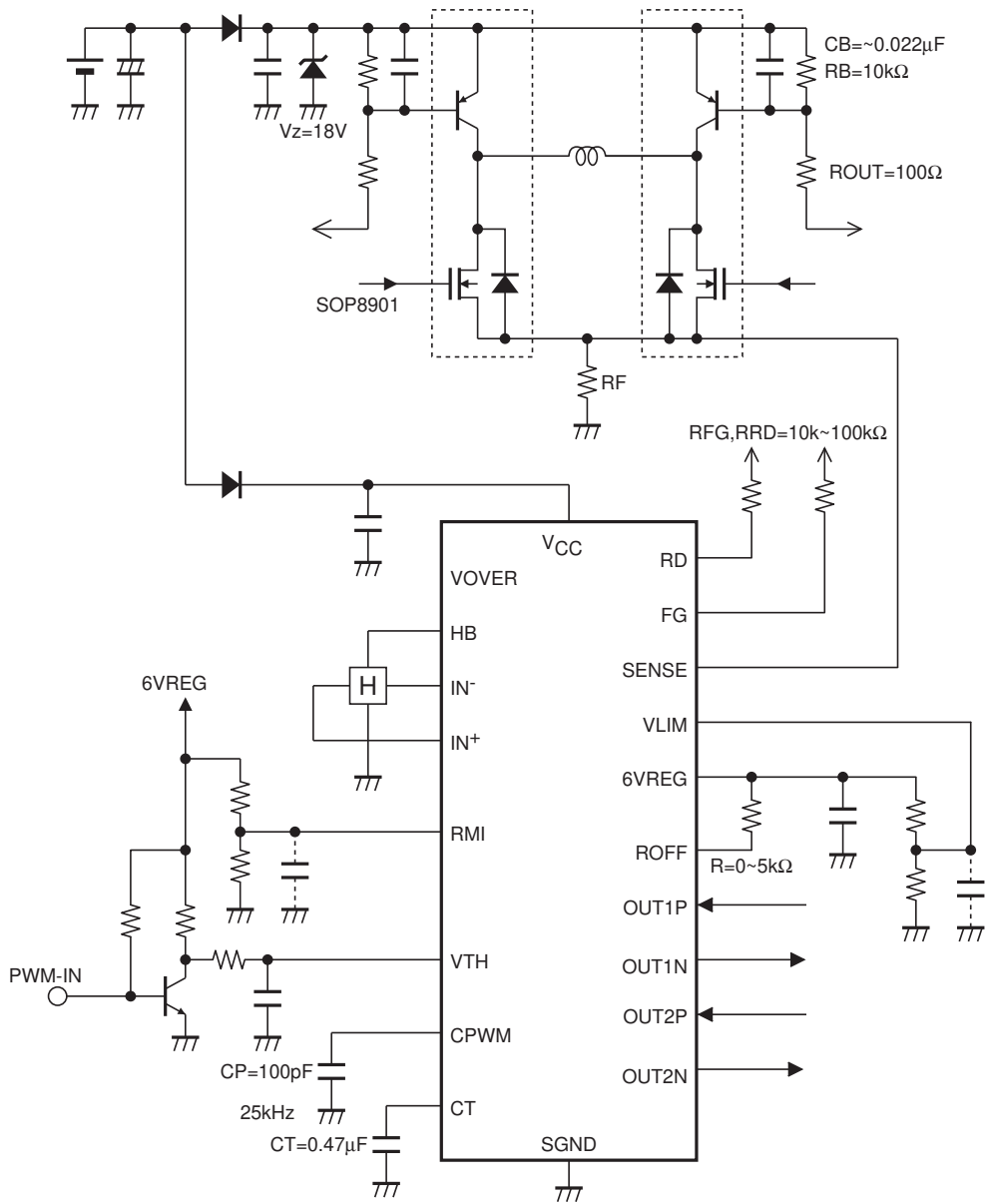

# LB11967V

## Sample Application Circuit 2 (24V, 48V)

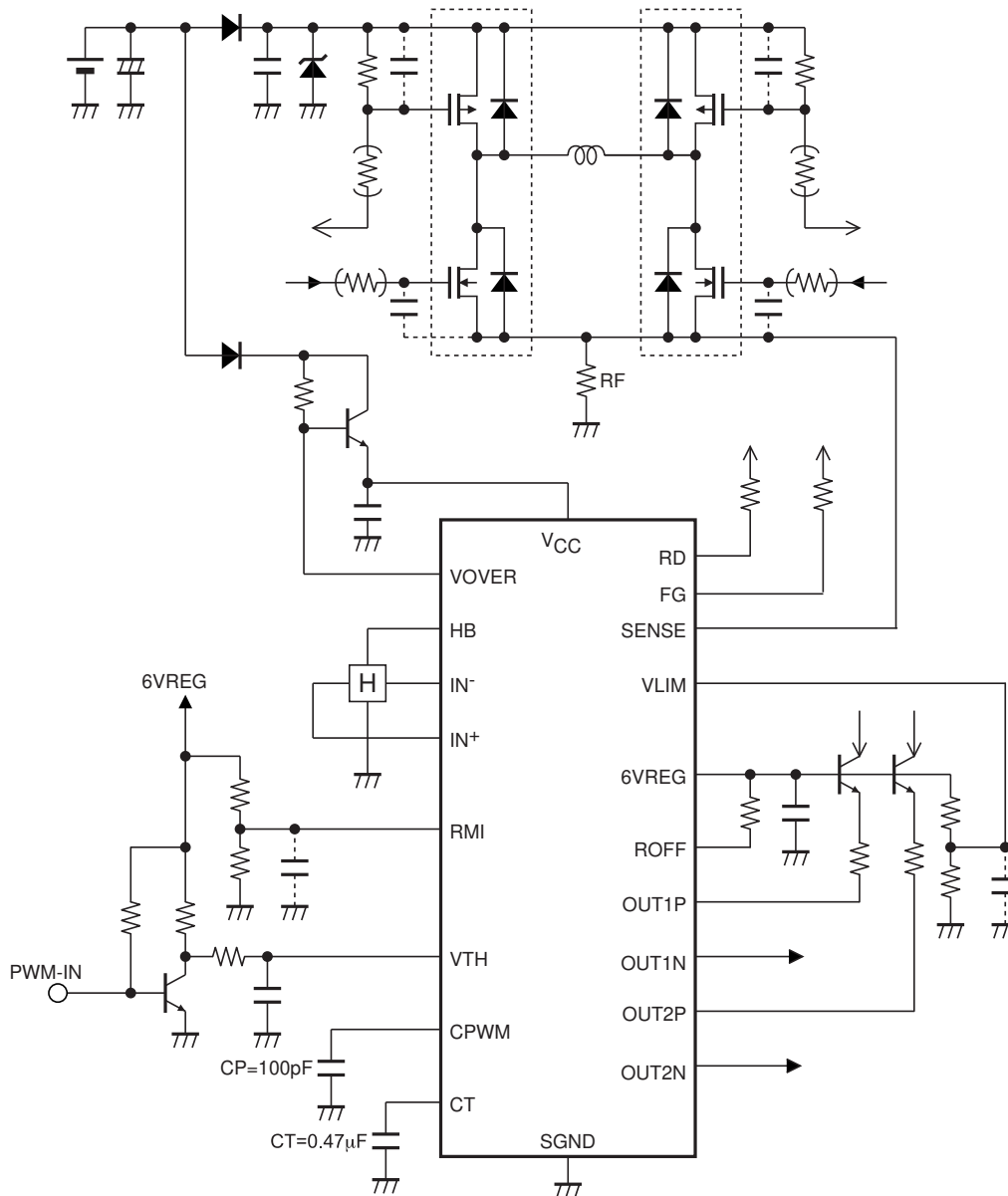



## LB11967V

- \*1. <Power supply-GND wiring>  
SGND is connected to the control circuit power supply system.
- \*2. <Power stabilization capacitor for regeneration>  
For the CM capacitor that is a power stabilization capacitor for PWM drive and for absorption of kick-back, the capacitance uses 0.1 $\mu$ F or more. In this IC, the lower Transistor performs current regeneration by means of switching of upper Transistor. Connect CM between VCC and GND with the thick pattern and along the shortest route.
- \*3. <Zener diode to stabilize power supply for regeneration>  
Be sure to use the zener diode if kick-back causes excessive increase of the supply voltage because such increase damages IC.
- \*4. <Hall input>  
Wiring need to be short to prevent carrying of the noise. If the noise is carried, insert a capacitor between IN+ and IN-. The Hall input circuit is a comparator having a hysteresis of 20mV. It is recommended that the Hall input level is more than three times (60mVp-p) this hysteresis.
- \*5. <Capacitor to set the PWM oscillation frequency>  
With CP = 100pF, oscillation occurs at f = 25kHz and provides the basic frequency of PWM.
- \*6. <RD output>  
This is the open collector output, which outputs "L" during rotation and "H" at stop. This output is left open when not used.
- \*7. <FG output>  
This is the open collector output, which can detect the rotation speed using the FG output according to the phase shift. This output is left open when not used.
- \*8. <HB pin>  
This is a Hall element bias pin, that is, the constant-voltage output pin.
- \*9. <RMI pin>  
This is the minimum speed setting pin, which is pulled up with 6VREG when not used.  
When IC power may possibly be turned OFF first when the pin is used, be sure to insert a current limiting resistor to prevent inflow of the large current. (The same applies to the VTH pin.)
- \*10. <ROFF pin>  
This pin sets the soft switching time to cut the reactive current before phase change and is connected to 6VREG when not used.
- \*11. <VLIM pin>  
This pin activates the current limiter when the SENSE pin voltage is higher than the VLIM pin voltage and is connected to 6VREG when not used.
- \*12. <SENSE pin>  
This is connected to GND when not used.
- \*13. <VOVER pin>  
This is a pin for constant-voltage bias and should be used for application of 24V and 48V. (Refer to the sample application circuit.) Be sure to use the current limiting resistor. This is left open when not used.

# LB11967V

## Control Timing Chart

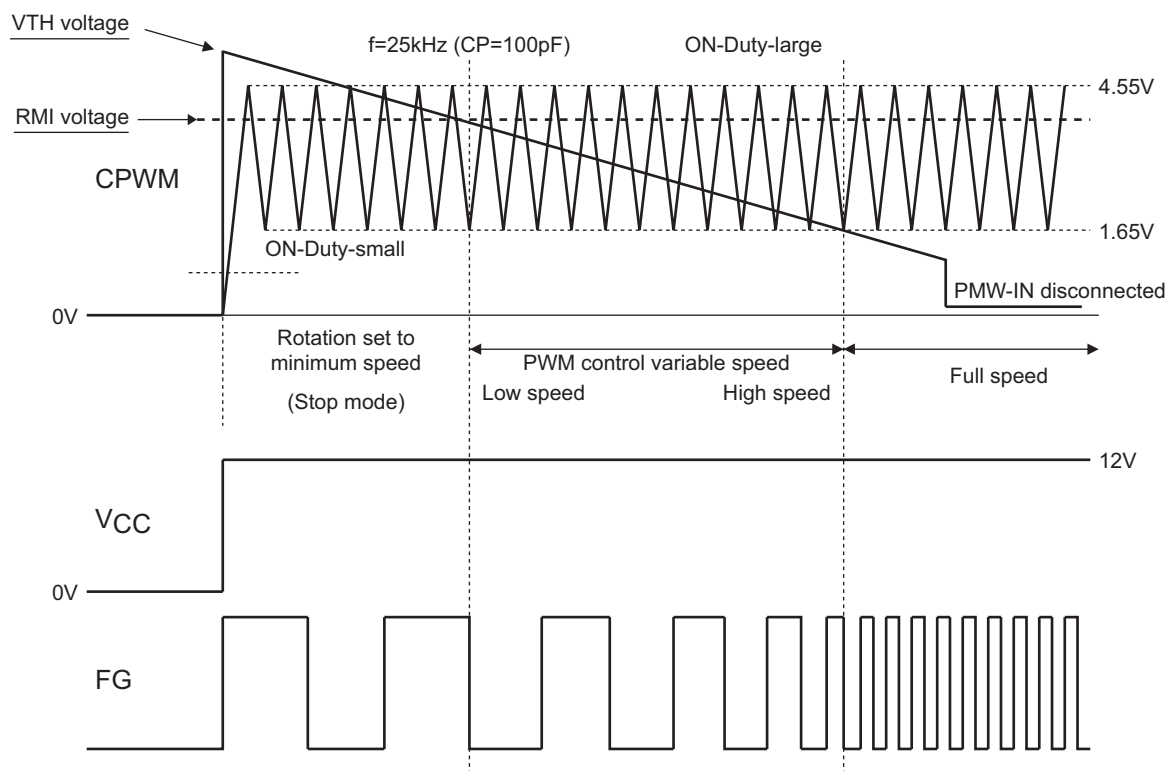

(1) Minimum speed setting (stop) mode

PWM-IN input is filtered to generate the VTH voltage. At low speed, the fan rotates with the minimum speed set with RMI pin during low speed. If the minimum speed is not set (RMI = 6VREG), the fan stops.

(2) Low↔High speed mode

PWM control is made through comparison of oscillation and VTH voltages with CPWM changing between 1.6V↔4.6V. When the VTH voltage is lower, the IC switches to drive mode. When the VTH voltage is higher, the p-channel FET is turned off and coil current is regenerated through the low-side FET. Therefore, as the VTH voltage lowers, the output ON-DUTY increases, increasing the coil current and raising the motor speed. The rotation speed is fed back by the FG output.

(3) Full speed mode

The full-speed mode becomes effective with the VTH voltage of 1.65V or less. (VTH must be equal to GND when the speed control is not to be made.)

(4) PWM-IN input disconnection mode

When the PWM-IN input pin is disconnected, VTH becomes 1.65V or less and the output enables full drive at 100%. The fan runs at full speed. (Refer to the sample application circuit.)

# LB11967V

## ORDERING INFORMATION

Device	Package	Wire Bond	Shipping(Qty/Packing)
LB11967V-MPB-H	SSOP20(225mil) (Pb-Free / Halogen Free)	Au-wire	70 / Fan-fold
LB11967V-TLM-H	SSOP20(225mil) (Pb-Free / Halogen Free)	Au-wire	2000 / Tape & Reel
LB11967V-W-AH	SSOP20(225mil) (Pb-Free / Halogen Free)	Cu-wire	2000 / Tape & Reel

† For information on tape and reel specifications, including part orientation and tape sizes, please refer to our Tape and Reel Packaging Specifications Brochure, BRD8011/D. [http://www.onsemi.com/pub\\_link/Collateral/BRD8011-D.PDF](http://www.onsemi.com/pub_link/Collateral/BRD8011-D.PDF)

ON Semiconductor and the ON Semiconductor logo are trademarks of Semiconductor Components Industries, LLC dba ON Semiconductor or its subsidiaries in the United States and/or other countries. ON Semiconductor owns the rights to a number of patents, trademarks, copyrights, trade secrets, and other intellectual property. A listing of ON Semiconductor's product/patent coverage may be accessed at [www.onsemi.com/site/pdf/Patent-Marking.pdf](http://www.onsemi.com/site/pdf/Patent-Marking.pdf). ON Semiconductor reserves the right to make changes without further notice to any products herein. ON Semiconductor makes no warranty, representation or guarantee regarding the suitability of its products for any particular purpose, nor does ON Semiconductor assume any liability arising out of the application or use of any product or circuit, and specifically disclaims any and all liability, including without limitation special, consequential or incidental damages. Buyer is responsible for its products and applications using ON Semiconductor products, including compliance with all laws, regulations and safety requirements or standards, regardless of any support or applications information provided by ON Semiconductor. "Typical" parameters which may be provided in ON Semiconductor data sheets and/or specifications can and do vary in different applications and actual performance may vary over time. All operating parameters, including "Typicals" must be validated for each customer application by customer's technical experts. ON Semiconductor does not convey any license under its patent rights nor the rights of others. ON Semiconductor products are not designed, intended, or authorized for use as a critical component in life support systems or any FDA Class 3 medical devices or medical devices with a same or similar classification in a foreign jurisdiction or any devices intended for implantation in the human body. Should Buyer purchase or use ON Semiconductor products for any such unintended or unauthorized application, Buyer shall indemnify and hold ON Semiconductor and its officers, employees, subsidiaries, affiliates, and distributors harmless against all claims, costs, damages, and expenses, and reasonable attorney fees arising out of, directly or indirectly, any claim of personal injury or death associated with such unintended or unauthorized use, even if such claim alleges that ON Semiconductor was negligent regarding the design or manufacture of the part. ON Semiconductor is an Equal Opportunity/Affirmative Action Employer. This literature is subject to all applicable copyright laws and is not for resale in any manner.