



Chipsmall Limited consists of a professional team with an average of over 10 year of expertise in the distribution of electronic components. Based in Hongkong, we have already established firm and mutual-benefit business relationships with customers from,Europe,America and south Asia,supplying obsolete and hard-to-find components to meet their specific needs.

With the principle of “Quality Parts,Customers Priority,Honest Operation,and Considerate Service”,our business mainly focus on the distribution of electronic components. Line cards we deal with include Microchip,ALPS,ROHM,Xilinx,Pulse,ON,Everlight and Freescale. Main products comprise IC,Modules,Potentiometer,IC Socket,Relay,Connector.Our parts cover such applications as commercial,industrial, and automotives areas.

We are looking forward to setting up business relationship with you and hope to provide you with the best service and solution. Let us make a better world for our industry!



## Contact us

Tel: +86-755-8981 8866 Fax: +86-755-8427 6832

Email & Skype: info@chipsmall.com Web: www.chipsmall.com

Address: A1208, Overseas Decoration Building, #122 Zhenhua RD., Futian, Shenzhen, China





SANYO Semiconductors

# DATA SHEET

An ON Semiconductor Company

## LB1830M

### Monolithic Digital IC Low-Voltage, Low-Saturation Bidirectional Motor Driver

#### Overview

The LB1830M is a low-saturation bidirectional motor driver IC with brake function for use in low-voltage applications. As both of forward and reverse outputs are regulated, it is especially suited for use in portable equipment.

#### Features

- Wide operating voltage range: 3.0 to 9.0 V
- Low saturation voltage: 0.2V at  $I_O = 40\text{mA}$  (typ)
- Low current drain at standby mode (0.1 $\mu\text{A}$  or less)
- Brake function
- Regulated voltage value (forward/reverse) setting available by one variable resistor
- Regulated output/saturation output switching available
- Built-in spark killer diodes
- Small package: MFP10S

#### Specifications

##### Absolute Maximum Ratings at $T_a = 25^\circ\text{C}$

Parameter	Symbol	Conditions	Ratings	Unit
maximum supply voltage	$V_{CC \text{ max}}, V_S \text{ max}$		10.5	V
Output current	$I_M \text{ max}$		500	mA
Input supply voltage	$V_{IN}$		-0.3 to +10	V
Allowable power dissipation	$P_d \text{ max}$	Independent IC	0.4	W
		Mounted on a specified board *	0.55	W
Operating temperature	$T_{opr}$		-20 to +80	$^\circ\text{C}$
Storage temperature	$T_{stg}$		-40 to +125	$^\circ\text{C}$

\* Specified board: 30mm  $\times$  30mm  $\times$  1.5mm, glass epoxy board.

Caution 1) Absolute maximum ratings represent the value which cannot be exceeded for any length of time.

Caution 2) Even when the device is used within the range of absolute maximum ratings, as a result of continuous usage under high temperature, high current, high voltage, or drastic temperature change, the reliability of the IC may be degraded. Please contact us for the further details.

■ Any and all SANYO Semiconductor Co.,Ltd. products described or contained herein are, with regard to "standard application", intended for the use as general electronics equipment. The products mentioned herein shall not be intended for use for any "special application" (medical equipment whose purpose is to sustain life, aerospace instrument, nuclear control device, burning appliances, transportation machine, traffic signal system, safety equipment etc.) that shall require extremely high level of reliability and can directly threaten human lives in case of failure or malfunction of the product or may cause harm to human bodies, nor shall they grant any guarantee thereof. If you should intend to use our products for new introduction or other application different from current conditions on the usage of automotive device, communication device, office equipment, industrial equipment etc. , please consult with us about usage condition (temperature, operation time etc.) prior to the intended use. If there is no consultation or inquiry before the intended use, our customer shall be solely responsible for the use.

■ Specifications of any and all SANYO Semiconductor Co.,Ltd. products described or contained herein stipulate the performance, characteristics, and functions of the described products in the independent state, and are not guarantees of the performance, characteristics, and functions of the described products as mounted in the customer's products or equipment. To verify symptoms and states that cannot be evaluated in an independent device, the customer should always evaluate and test devices mounted in the customer's products or equipment.

**SANYO Semiconductor Co., Ltd.**

[www.semicon.sanyo.com/en/network](http://www.semicon.sanyo.com/en/network)

# LB1830M

## Allowable Operating Ranges at Ta = 25°C

Parameter	Symbol	Conditions	Ratings	Unit
Supply voltage	V <sub>CC</sub> , V <sub>S</sub>		3.0 to 9.0	V
Input high level voltage	V <sub>IH</sub>		2.0 to 9.0	V
Input low level voltage	V <sub>IL</sub>		-0.3 to +0.3	V
Control voltage	V <sub>C</sub>		1.0 to 6.0	V

## Electrical Characteristics at Ta = 25°C, V<sub>CC</sub> = 6V

Parameter	Symbol	Conditions	Ratings			Unit
			min	typ	max	
Current drain	I <sub>CC0</sub>	IN1 = IN2 = V <sub>m</sub> = 0V, V <sub>C</sub> = V <sub>ref</sub> at standby mode		0.1	10	μA
	I <sub>CC1</sub>	Forward/reverse, control, load OPEN		2	3	mA
	I <sub>CC2</sub>	Forward/reverse, saturation, load OPEN		3	5	mA
	I <sub>CC3</sub>	Braking, load OPEN		5	8	mA
Output saturation voltage	V <sub>sat1</sub>	I <sub>O</sub> = 40mA (upper side + lower side)		0.2	0.3	V
	V <sub>sat2</sub>	I <sub>O</sub> = 80mA (upper side + lower side)		0.4	0.6	V
Reference voltage	V <sub>ref</sub>	I <sub>Vref</sub> = 1mA	1.85	2.0	2.15	V
Voltage characteristics of output voltage	$\frac{\Delta V_O}{\Delta V_{CC}}$	V <sub>O</sub> = 5V, V <sub>CC</sub> = 5.5 to 9V, I <sub>O</sub> = 40mA			80	mA
Current characteristics of output voltage	$\frac{\Delta V_O}{\Delta I_O}$	V <sub>O</sub> = 5V, V <sub>CC</sub> = 6V, I <sub>O</sub> = 10 to 80mA			50	mA
Input current	I <sub>IN</sub>	V <sub>IN</sub> = 5V		90	150	μA
Output voltage	V <sub>O</sub>	V <sub>C</sub> = 2V	2.3×V <sub>C</sub>		2.5×V <sub>C</sub>	V

## Package Dimensions

unit : mm (typ)

3086B

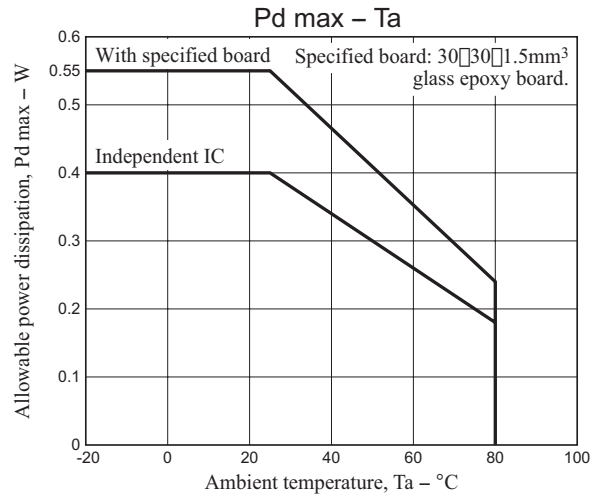
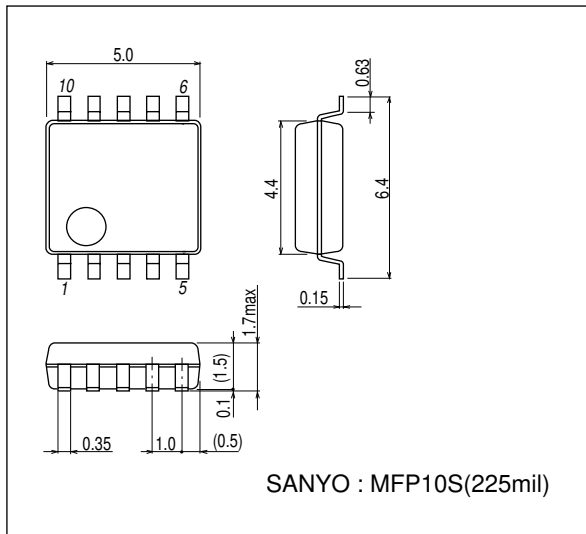

# LB1830M

## Pin Assignment

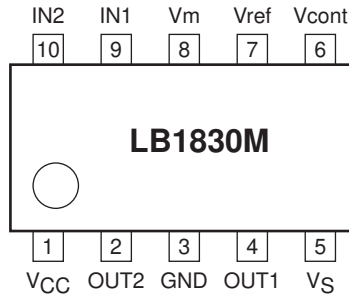

## Block Diagram

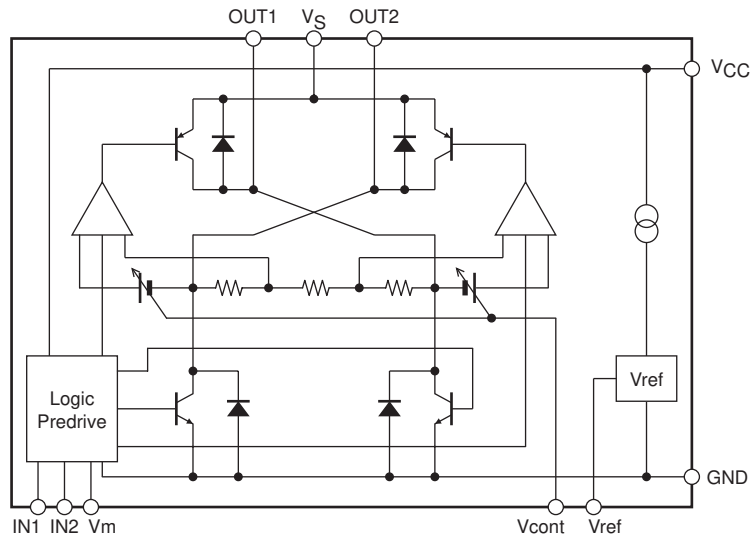

- The constant-voltage drive mode output voltage (the voltage between the output pins)  $V_O$  is determined by the following formula.  $V_O = (V_{cont} \text{ pin input voltage}) \times 2.4$  (typical)
- There are no restrictions on the relative magnitudes between the following voltages:  $V_{CC}$  (control system supply voltage),  $V_S$  (motor supply voltage), and  $IN1/IN2/V_m$  (the input signal voltages).

## Truth Table

Input			Output		Mode
IN1	IN2	$V_m$	OUT1	OUT2	
L	L	L	OFF	OFF	Standby
H	L	L	H	L	Forward (Regulated)
H	L	H	H	L	Forward (Saturation)
L	H	L	L	H	Reverse (Regulated)
L	H	H	L	H	Reverse (Saturation)
H	H	*	L	L	Brake

\* when in saturation mode,  $V_C = V_S$  available.

## Application Circuit Example

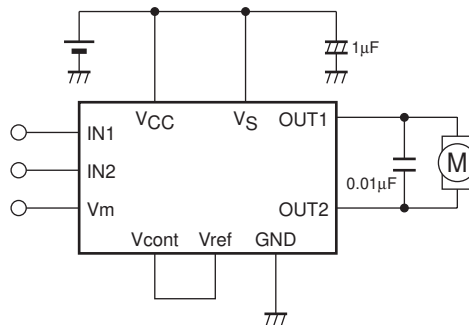

- SANYO Semiconductor Co.,Ltd. assumes no responsibility for equipment failures that result from using products at values that exceed, even momentarily, rated values (such as maximum ratings, operating condition ranges, or other parameters) listed in products specifications of any and all SANYO Semiconductor Co.,Ltd. products described or contained herein.
- SANYO Semiconductor Co.,Ltd. strives to supply high-quality high-reliability products, however, any and all semiconductor products fail or malfunction with some probability. It is possible that these probabilistic failures or malfunction could give rise to accidents or events that could endanger human lives, trouble that could give rise to smoke or fire, or accidents that could cause damage to other property. When designing equipment, adopt safety measures so that these kinds of accidents or events cannot occur. Such measures include but are not limited to protective circuits and error prevention circuits for safe design, redundant design, and structural design.
- In the event that any or all SANYO Semiconductor Co.,Ltd. products described or contained herein are controlled under any of applicable local export control laws and regulations, such products may require the export license from the authorities concerned in accordance with the above law.
- No part of this publication may be reproduced or transmitted in any form or by any means, electronic or mechanical, including photocopying and recording, or any information storage or retrieval system, or otherwise, without the prior written consent of SANYO Semiconductor Co.,Ltd.
- Any and all information described or contained herein are subject to change without notice due to product/technology improvement, etc. When designing equipment, refer to the "Delivery Specification" for the SANYO Semiconductor Co.,Ltd. product that you intend to use.
- Upon using the technical information or products described herein, neither warranty nor license shall be granted with regard to intellectual property rights or any other rights of SANYO Semiconductor Co.,Ltd. or any third party. SANYO Semiconductor Co.,Ltd. shall not be liable for any claim or suits with regard to a third party's intellectual property rights which has resulted from the use of the technical information and products mentioned above.

This catalog provides information as of October, 2011. Specifications and information herein are subject to change without notice.