



Chipsmall Limited consists of a professional team with an average of over 10 year of expertise in the distribution of electronic components. Based in Hongkong, we have already established firm and mutual-benefit business relationships with customers from,Europe,America and south Asia,supplying obsolete and hard-to-find components to meet their specific needs.

With the principle of “Quality Parts,Customers Priority,Honest Operation,and Considerate Service”,our business mainly focus on the distribution of electronic components. Line cards we deal with include Microchip,ALPS,ROHM,Xilinx,Pulse,ON,Everlight and Freescale. Main products comprise IC,Modules,Potentiometer,IC Socket,Relay,Connector.Our parts cover such applications as commercial,industrial, and automotives areas.

We are looking forward to setting up business relationship with you and hope to provide you with the best service and solution. Let us make a better world for our industry!



Contact us

Tel: +86-755-8981 8866 Fax: +86-755-8427 6832

Email & Skype: info@chipsmall.com Web: www.chipsmall.com

Address: A1208, Overseas Decoration Building, #122 Zhenhua RD., Futian, Shenzhen, China





LB1863M, 1869M

Two-Phase Unipolar Brushless Motor Driver Automatic Recovery Type Circuit in a Miniature Flat Package

An ON Semiconductor Company

Overview

The LB1863M and LB1869M are 2-phase unipolar brushless motor drivers that are provided in a miniature flat package that contributes to end product miniaturization and supports automatic mounting. These products support the implementation of motor drive lock protection and automatic recovery circuits, and alarm specifications with a minimal number of external components.

Features and Functions

- Hall elements can be connected directly to the IC itself.
- 1.5-A output current output transistors built in
- Rotation detection function that provides a low-level output during motor drive and a high-level output when the motor is stopped
- Motor lock protection and automatic recovery functions built in
- Thermal shutdown circuit
- Switching noise can be reduced with an external ceramic capacitor.

Classification

Package	MFP-14S
System voltage	
12 V	LB1869M
24 V	LB1863M

Note: The LB1869M and LB1863M are pin compatible so that the same printed circuit board can be used for both 12 V and 24 V products.

Package Dimensions

unit: mm

3111-MFP14S

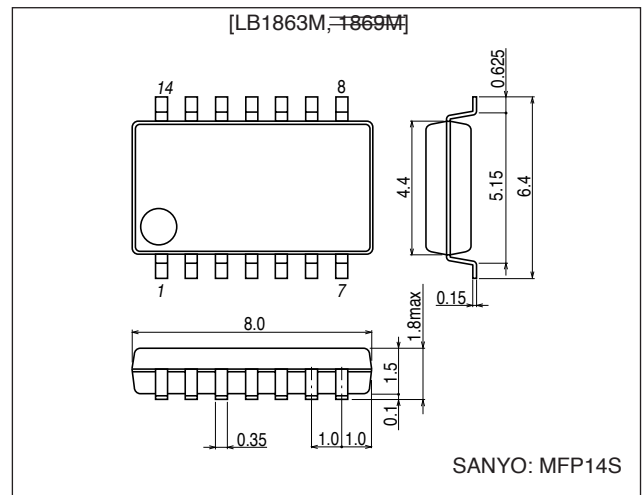

- Any and all SANYO products described or contained herein do not have specifications that can handle applications that require extremely high levels of reliability, such as life-support systems, aircraft's control systems, or other applications whose failure can be reasonably expected to result in serious physical and/or material damage. Consult with your SANYO representative nearest you before using any SANYO products described or contained herein in such applications.
- SANYO assumes no responsibility for equipment failures that result from using products at values that exceed, even momentarily, rated values (such as maximum ratings, operating condition ranges, or other parameters) listed in products specifications of any and all SANYO products described or contained herein.

Specifications

Absolute Maximum Ratings at Ta = 25°C

Parameter	Symbol	Conditions	Ratings	Unit
Maximum input current	I _{CC} max	t ≤ 20 ms	200	mA
Output voltage	V _{OUT}	LB1863M	-0.3 to +85	V
		LB1869M	-0.3 to +60	V
Output current	I _{OUT}		1.5	A
RD influx current	I _{RD}		10	mA
RD voltage	V _{RD}		30	V
Allowable power dissipation	Pd max	When mounted (on a 20 × 15 × 1.5-mm ³ glass-epoxy printed circuit board)	800	mW
Operating temperature	T _{opr}		-30 to +80	°C
Storage temperature	T _{stg}		-55 to +150	°C

Allowable Operating Ranges at Ta = 25°C

Parameter	Symbol	Conditions	Ratings	Unit
Input current range	I _{CC}		6.0 to 50	mA
Common-mode input voltage range	V _{ICM}		0 to V _{IN} - 1.5	V

Electrical Characteristics at Ta = 25°C, I_{CC} = 10 mA

Parameter	Symbol	Conditions	Ratings			Unit
			min	typ	max	
Output voltage 1	V _{OR}	LB1863M	80			V
		LB1869M	60			V
Output voltage 2	V _{O(SUS)}	LB1863M : I _O = 0.1 A	65			V
		LB1869M : I_O = 0.1 A	40			V
Output saturation voltage	V _{O(sat)1}	I _O = 0.5 A		0.95	1.2	V
	V _{O(sat)2}	I _O = 1.0 A		1.15	1.5	V
Input voltage	V _{IN}	I _{CC} = 7.0 mA	6.4	6.7	7.0	V
Amplifier input offset voltage	V _{OFF}		-7	0	+7.0	mV
Amplifier input bias current	I _{BA}		-250			nA
RD output saturation voltage	V _{RD(sat)}	I _{RD} = 5 mA		0.1	0.3	V
Capacitor discharge current	I _{C1}		2.1	3	3.9	μA
	I _{C2}		0.31	0.44	0.59	μA
Comparator input threshold voltage	V _{TH1}		0.77	0.8V _{IN}	0.83	V
	V _{TH2}		0.42	0.45V _{IN}	0.48	V

Pin Assignment

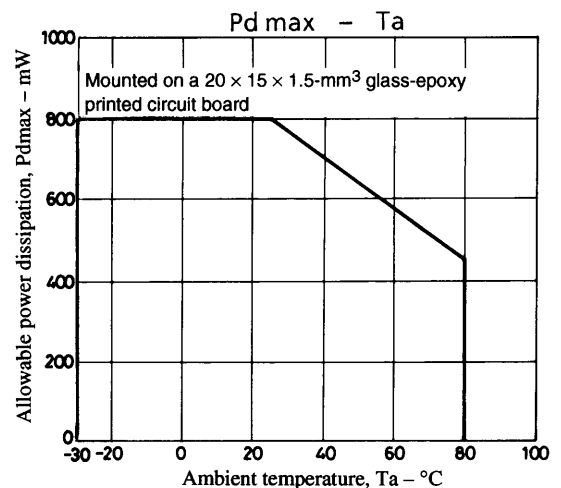
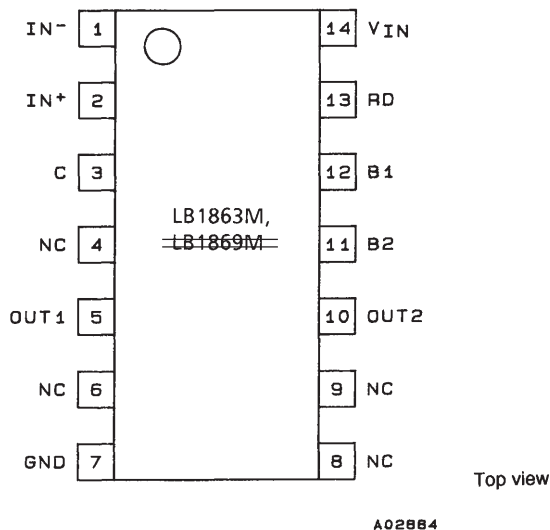

Equivalent Circuit, Block Diagram, and Sample Application

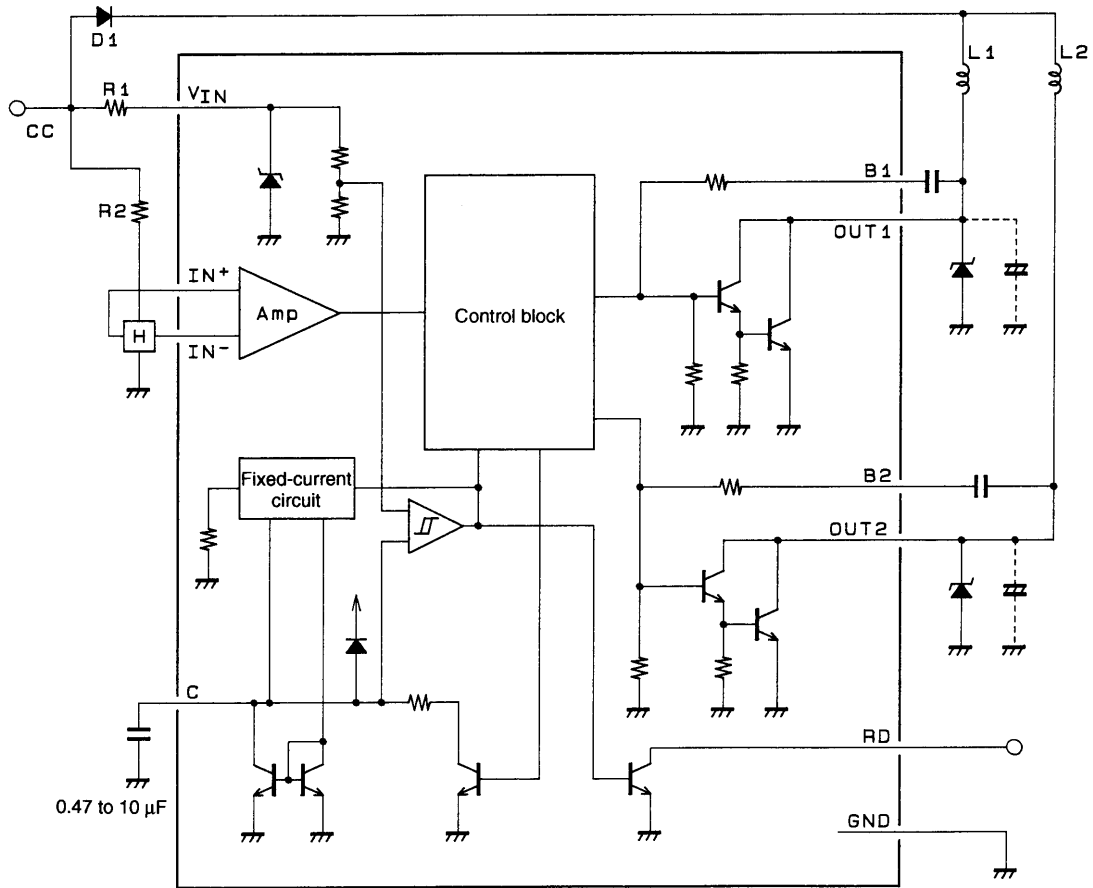

A02886

Sample Application Circuit

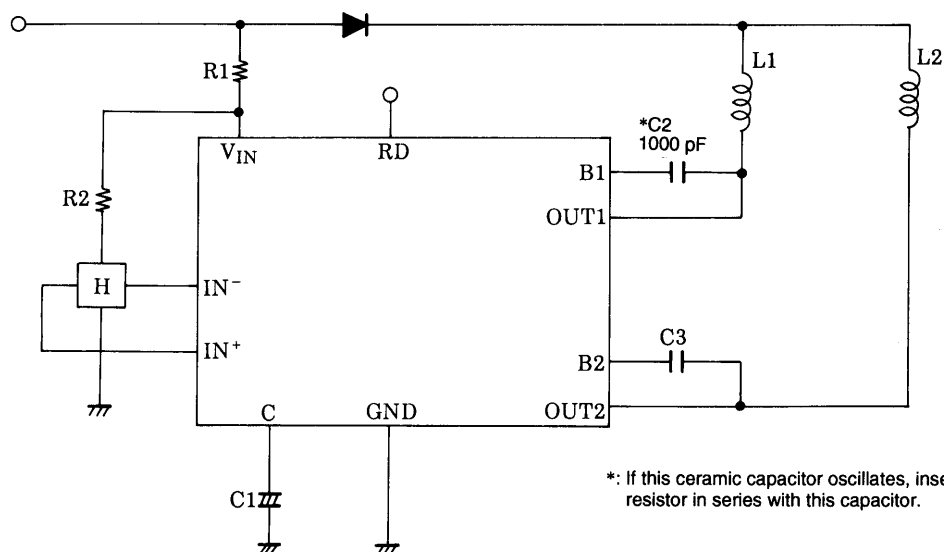

*: If this ceramic capacitor oscillates, insert a resistor in series with this capacitor.

Sample Application Circuit Output Waveforms

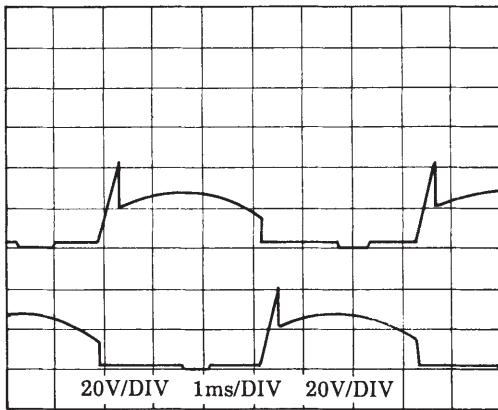

Truth Table

IN ⁺	IN ⁻	C	OUT1	OUT2	RD
H	L	L	H	L	L
L	H	L	L	H	L
H	L	H	H	H	H
L	H	H	H	H	H

Design Documentation (See the application circuit diagram.)

1. Power-supply voltage (V_{IN} pin)

Since these miniature flat package products supply power to the Hall amplifier block and the control block from an internal parallel regulator, they operate with good stability with respect to kickback currents from the motor and variations in the power-supply voltage. They also provide an adequate ability to withstand surges. The resistor R1 between the V_{CC} and V_{IN} pins should be set up so that a current in the range I_{CC} = 6 to 50 mA flows into the V_{IN} pin in the fan motor power-supply voltage range.

V_{IN} has a typical value of 6.7 volts when I_{CC} is 7 mA. The current flowing into V_{IN} can be calculated with the following formula.

$$I_{CC} = \frac{V_{CC} - V_{IN}}{R1} \dots\dots\dots(1)$$

• Abnormal voltage considerations

The maximum allowable current for the V_{IN} pin is 200 mA. Therefore, the IC design allows it to withstand voltages up to the plus side abnormal voltage V_{surge} give by formula (2).

$$V_{surge} = V_{IN} + R1 \times 200 \text{ mA} \dots\dots(2)$$

2. Hall input pin voltages (IN⁻ and IN⁺ pins)

The Hall element output voltages to the Hall element input pins must be in the range 0 to (V_{IN} - 1.5 V). The gain from the Hall input pins to the output pin is over 100 dB. The Hall input amplifier offset voltage is ±7 mV. This means that the Hall element output must be set up taking this ±7 mV offset into account.

3. Output transistors (OUT1 and OUT2 pins)

Output current: I_O = 1.5 A maximum

Output saturation voltage: V_{Osat} = 1.15V/1.0 A (typical)

Applications should adopt one of the following three output protection techniques.

- ① If a capacitor is inserted between OUT and ground, use a capacitor with a value up to C = 10 μF, and design that value so that the kickback and reverse voltages do not exceed V_{OR}.
- ② If a Zener diode is added, determine a value for the Zener voltage that is lower than V_{O(SUS)}. If radio-frequency noise is a problem, insert a capacitor between B1 and B2.
- ③ If a capacitor is inserted between OUT and B1, set the capacitor value so that the kickback voltage is lower than V_{O(SUS)}. If oscillation occurs, insert a resistor in series with the capacitor.

4. Output protection function (C pin)

This pin connects the capacitor that forms the automatic recovery circuit. If rotation stops due to, for example, a motor overload, the pin voltage rises and the output stops. The system automatically recovers from stopped to drive mode when the load is set to an appropriate level. The lock detection time can be set by changing the value of the capacitor.

For a 1- μ F capacitor: Lock detection time About 2 seconds
 Lock protection time (output on) About 1 second
 (output off) About 6 seconds

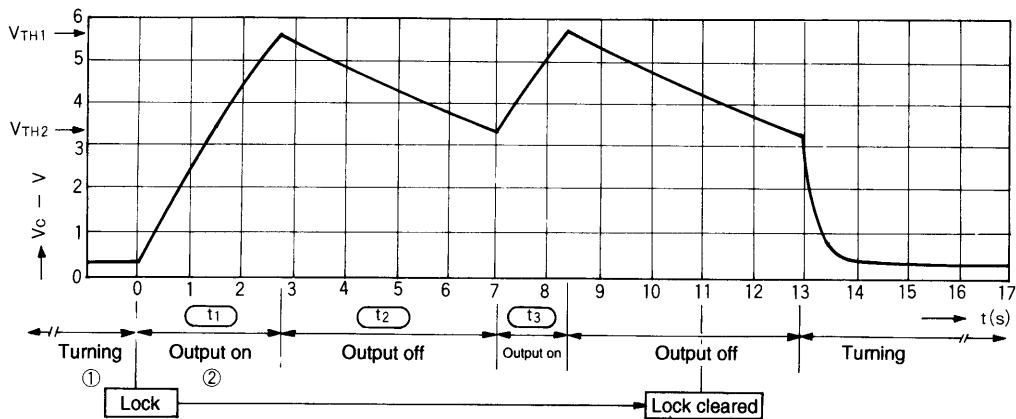

Automatic recovery circuit pin C voltage

- ① While the blades are turning, the capacitor is charged with a current of about 3 μ A (typical), and C is discharged by pulses that correspond to the motor speed.
- ② When the blades lock, the capacitor is no longer discharged, and the voltage across the capacitor increases. The output is turned off when that voltage reaches $0.8 \times V_{IN}$.
- ③ When the output is turned off, the capacitor is discharged at a current of about 0.44 μ A (typical). When the capacitor voltage falls under V_{TH2} , if the lock state is not yet cleared the capacitor continues discharging until V_{TH1} . (Note that the output is turned on at this time.) These operations, i.e. items ② and ③, are repeated with a ton:toff ratio of about 1:6 to protect the motor.
- ④ If the lock state has been cleared when the capacitor voltage reaches V_{TH2} , motor rotation is started by turning the output on.

5. Rotation detection signal (RD pin)

This is an open collector output, and outputs a low level in drive mode and a high level when the motor is stopped.

6. Radio-frequency noise reduction function (B1 and B2 pins)

These are base pins for Darlington pair outputs. Add capacitors of about 0.01 to 0.1 μ F if radio-frequency noise is a problem.

7. Thermal shutdown function

Turns off the output in response to coil shorting or IC overheating.

- Specifications of any and all SANYO products described or contained herein stipulate the performance, characteristics, and functions of the described products in the independent state, and are not guarantees of the performance, characteristics, and functions of the described products as mounted in the customer's products or equipment. To verify symptoms and states that cannot be evaluated in an independent device, the customer should always evaluate and test devices mounted in the customer's products or equipment.
- SANYO Electric Co., Ltd. strives to supply high-quality high-reliability products. However, any and all semiconductor products fail with some probability. It is possible that these probabilistic failures could give rise to accidents or events that could endanger human lives, that could give rise to smoke or fire, or that could cause damage to other property. When designing equipment, adopt safety measures so that these kinds of accidents or events cannot occur. Such measures include but are not limited to protective circuits and error prevention circuits for safe design, redundant design, and structural design.
- In the event that any or all SANYO products (including technical data, services) described or contained herein are controlled under any of applicable local export control laws and regulations, such products must not be exported without obtaining the export license from the authorities concerned in accordance with the above law.
- No part of this publication may be reproduced or transmitted in any form or by any means, electronic or mechanical, including photocopying and recording, or any information storage or retrieval system, or otherwise, without the prior written permission of SANYO Electric Co., Ltd.
- Any and all information described or contained herein are subject to change without notice due to product/technology improvement, etc. When designing equipment, refer to the "Delivery Specification" for the SANYO product that you intend to use.
- Information (including circuit diagrams and circuit parameters) herein is for example only; it is not guaranteed for volume production. SANYO believes information herein is accurate and reliable, but no guarantees are made or implied regarding its use or any infringements of intellectual property rights or other rights of third parties.

This catalog provides information as of July, 1999. Specifications and information herein are subject to change without notice.