



Chipsmall Limited consists of a professional team with an average of over 10 year of expertise in the distribution of electronic components. Based in Hongkong, we have already established firm and mutual-benefit business relationships with customers from,Europe,America and south Asia,supplying obsolete and hard-to-find components to meet their specific needs.

With the principle of “Quality Parts,Customers Priority,Honest Operation,and Considerate Service”,our business mainly focus on the distribution of electronic components. Line cards we deal with include Microchip,ALPS,ROHM,Xilinx,Pulse,ON,Everlight and Freescale. Main products comprise IC,Modules,Potentiometer,IC Socket,Relay,Connector.Our parts cover such applications as commercial,industrial, and automotives areas.

We are looking forward to setting up business relationship with you and hope to provide you with the best service and solution. Let us make a better world for our industry!



## Contact us

Tel: +86-755-8981 8866 Fax: +86-755-8427 6832

Email & Skype: info@chipsmall.com Web: www.chipsmall.com

Address: A1208, Overseas Decoration Building, #122 Zhenhua RD., Futian, Shenzhen, China





ON Semiconductor®

<http://onsemi.com>

# LB1962MC

## Monolithic Digital IC For Fan Motor Single-Phase Full-Wave Driver

### Overview

Single-phase full-wave drive design and a compact package make these ICs optimal for small fans (especially CPU cooling fans). Low switching noise and effective motor drive are further advantages.

### Functions

- Support for 5V/12V dual power supply voltage
- Built-in regenerative circuit allows use of reverse connection protection diode
- Built-in Hall amplifier with hysteresis (supports core without auxiliary electrode)
- Built-in lockup protection and automatic recovery circuits
- Rotation detection output (FG)
- Hall bias pin and start/stop pin allow reduced current drain in standby mode
- Built-in thermal protection circuit

### Specifications

**Absolute Maximum Ratings** at  $T_a = 25^\circ\text{C}$

Parameter	Symbol	Conditions	Ratings	Unit
Maximum supply voltage	$V_{CC \text{ max}}$		17	V
Maximum output current	$I_{OUT \text{ max}}$		0.5	A
Maximum output withstand voltage	$V_{OUT \text{ max}}$		17	V
FG maximum output withstand voltage	$V_{FG \text{ max}}$		17	V
FG maximum output current	$I_{FG \text{ max}}$		5	mA
HB maximum output current	$I_B \text{ max}$		10	mA
ST maximum input voltage	$V_{ST \text{ max}}$		15	V
Allowable power dissipation	$P_d \text{ max}$	Mounted on a specified board *	800	mW
Operating temperature	$T_{opr}$		-30 to +90	$^\circ\text{C}$
Storage temperature	$T_{stg}$		-55 to +150	$^\circ\text{C}$

\* Specified board: 114.3mm × 76.2mm × 1.6mm, glass epoxy board.

Caution 1) Absolute maximum ratings represent the value which cannot be exceeded for any length of time.

Caution 2) Even when the device is used within the range of absolute maximum ratings, as a result of continuous usage under high temperature, high current, high voltage, or drastic temperature change, the reliability of the IC may be degraded. Please contact us for the further details.

Stresses exceeding Maximum Ratings may damage the device. Maximum Ratings are stress ratings only. Functional operation above the Recommended Operating Conditions is not implied. Extended exposure to stresses above the Recommended Operating Conditions may affect device reliability.

# LB1962MC

## Allowable Operating Conditions at $T_a = 25^\circ\text{C}$

Parameter	Symbol	Conditions	Ratings	Unit
Power supply voltage	$V_{CC}$		3.8 to 16.8	V
ST input High level voltage	$ST_H$		3 to 14	V
ST input Low level voltage	$ST_L$		-0.3 to +0.4	V
Hall input common mode voltage	$V_{ICM}$		0.2 to $V_{CC}-1.5$	V

## Electrical Characteristics at $T_a = 25^\circ\text{C}$ , $V_{CC} = 5\text{V}$

Parameter	Symbol	Conditions	Ratings			Unit
			min	typ	max	
Current drain	$I_{CC}$	In drive mode (CT = "L", ST = "L")		6.5	9.1	mA
		In lockup protection mode (CT = "H", ST = "L")		2.2	3.1	mA
		In standby mode (ST = "H")		110	150	$\mu\text{A}$
Lockup detection capacitor charge current	$I_{CT1}$		1.9	2.8	3.7	$\mu\text{A}$
Capacitor discharge current	$I_{CT2}$		0.32	0.46	0.60	$\mu\text{A}$
Capacitor charge/discharge current ratio	$R_{CT}$	$R_{CT} = I_{CT1}/I_{CT2}$	5.0	6.0	7.0	
CT charge voltage	$V_{CT1}$		2.55	2.75	2.95	V
CT discharge voltage	$V_{CT2}$		1.6	1.8	2.0	V
Output Low level voltage	$V_{OL}$	$I_O = 200\text{mA}$		0.2	0.3	V
Output High level voltage	$V_{OH}$	$I_O = 200\text{mA}$	3.9	4.1		V
Hall input sensitivity	$V_{HN}$	Zero peak value (Including offset and hysteresis)		7	15	mV
FG output pin Low voltage	$V_{FG}$	$I_{FG} = 5\text{mA}$		0.1	0.3	V
FG output pin leakage current	$I_{FGL}$	$V_{FG} = 15\text{V}$			30	$\mu\text{A}$
HB output Low voltage	$V_{HBL}$	$I_{HB} = 5\text{mA}$		1.0	1.3	V
ST pin input current	$I_{ST}$	$V_{ST} = 5\text{V}$		75	100	$\mu\text{A}$

## Package Dimensions

unit : mm (typ)

3426A

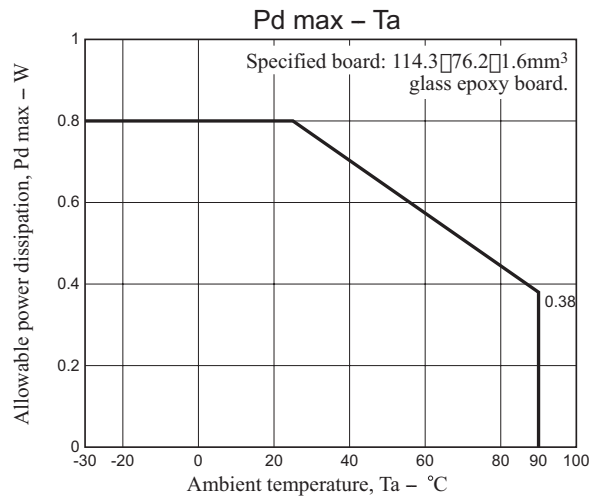
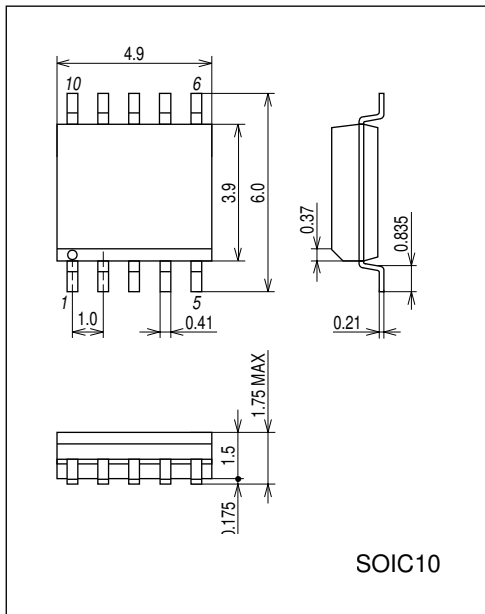

# LB1962MC

## Pin Assignment

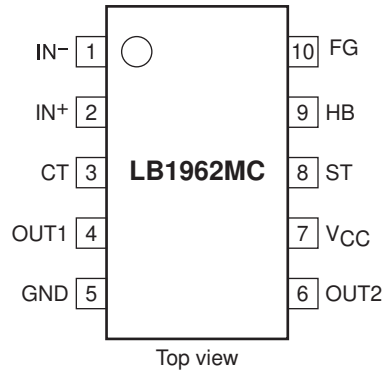

## Block Diagram

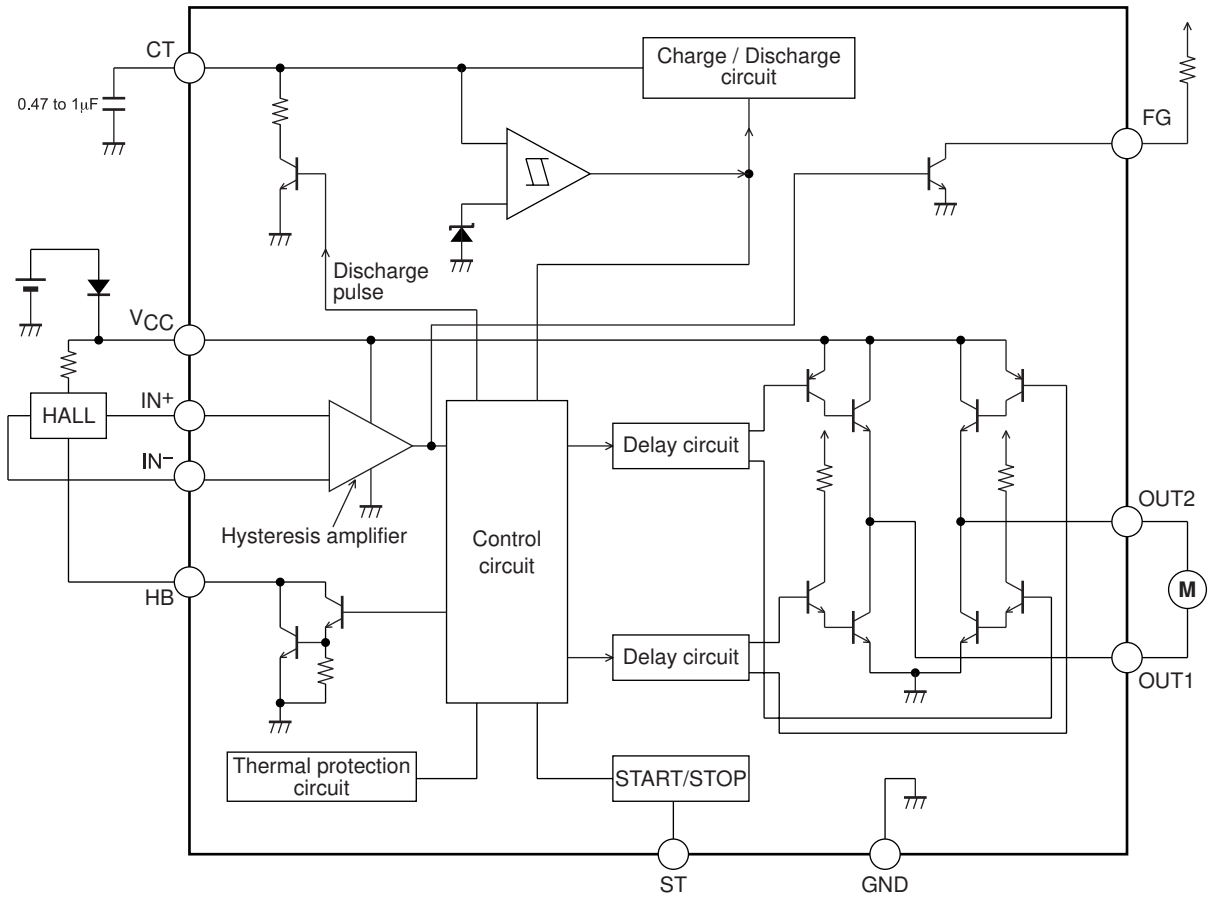

## Truth Table

ST	IN-	IN+	CT	OUT1	OUT2	FG	HB	Mode
H	-	-	-	OFF	OFF	OFF	OFF	Standby
L	H	L	L	H	L	L	L	Rotating
	L	H		L	H	H		
-	-	-	H	OFF	OFF	-	L	Lockup protection activated

Latch-type RD output is Low during rotation and High during stop.

Startup

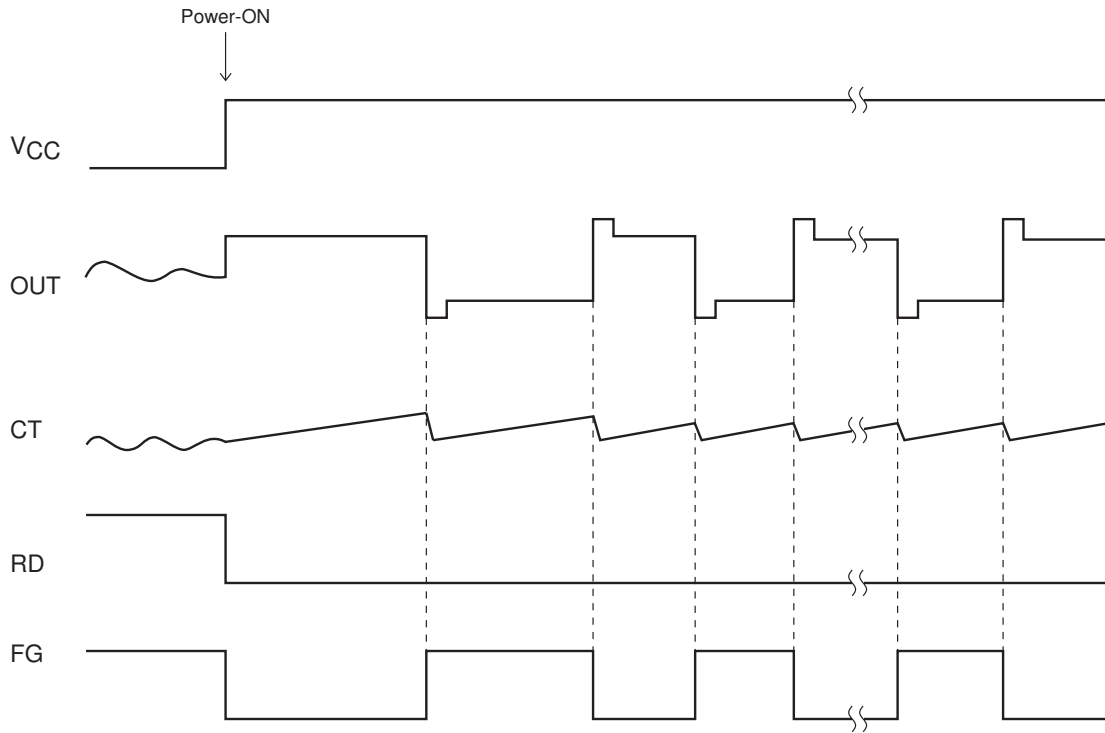

Lockup protection/automatic recovery

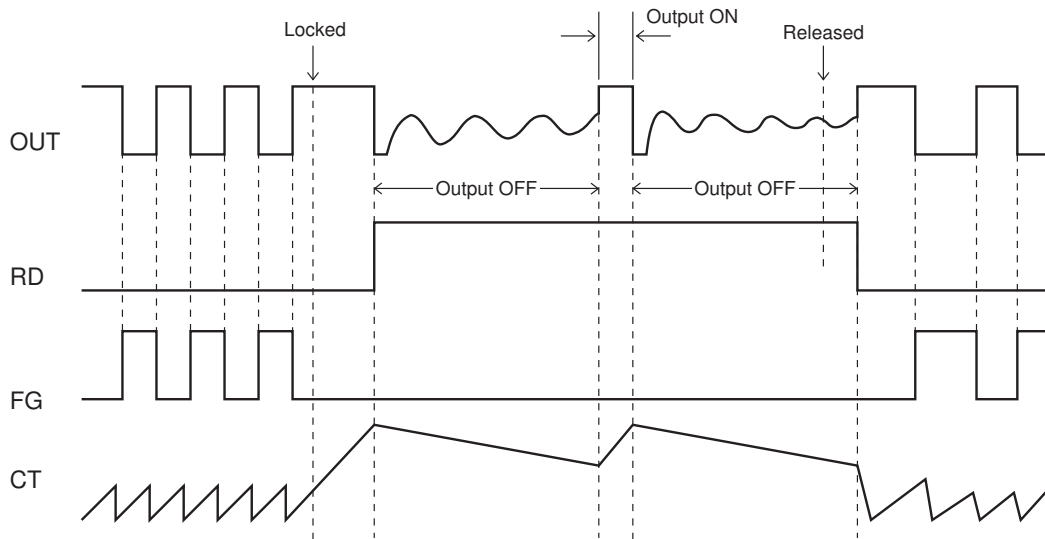

Start/stop

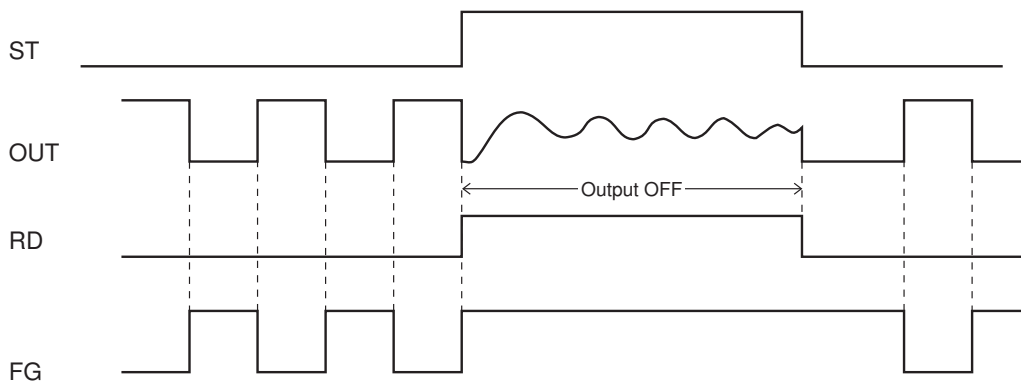

## Design Reference

(1) V<sub>CC</sub> pin

Power supply pin for control block and motor drive.

Accepts a wide operation voltage range from 3.8 to 16.8V, for 5V/12V dual power supply support.

(2) OUT1, OUT2 pins

Single-phase coil output pins.

Bipolar drive output with upper side inverted and lower side single output. Built-in regenerative circuit regenerates kickback current between lower side NPN outputs when a diode is used for protection against reverse connection.

(3) IN<sup>-</sup>, IN<sup>+</sup> pins

Hall input signal pins

The Hall signal is amplified into a square wave by the Hall amplifier with hysteresis characteristics of  $\pm 3.5\text{mV}$  (typ.).

The Hall input signal amplitude should be 70mV or more.

(4) CT pin

This pin serves for connecting a capacitor between CT and GND.

The capacitor determines the characteristics of the built-in lockup protection circuit for preventing coil burnout in the case of motor restraint. Once normal motor load is restored, the automatic recovery circuit resets itself.

Changing the capacitance alters the lockup detection time.

When a 0.47 mF capacitor is connected between CT and GND

Lockup detection time : approx. 0.5s

Lockup protection time/automatic recovery time : approx. 0.16s (output ON)

approx. 1s (output OFF)

When not using lockup protection function, this pin should be connected to ground.

(5) FG pin

Open-collector output pin for rotation frequency detection.

When IN<sup>-</sup> = High and IN<sup>+</sup> = Low, then FG = Low

When IN<sup>-</sup> = Low and IN<sup>+</sup> = High, then FG = High

(6) ST pin and HB pin

ST pin : When input to this pin is High, motor drive is stopped (OUT is high impedance).

At this time, RD output indicates lockup protection mode OFF.

HB pin : Hall bias switching pin. At ST pin High input, Hall bias is switched to reduce current drain in fan standby mode.

If not used, both pins should be open.

(7) Thermal protection circuit

When internal temperature T<sub>j</sub> of IC reaches 180°C, output current limiter is activated to protect against damage.



# LB1962MC

## Application Circuit Example

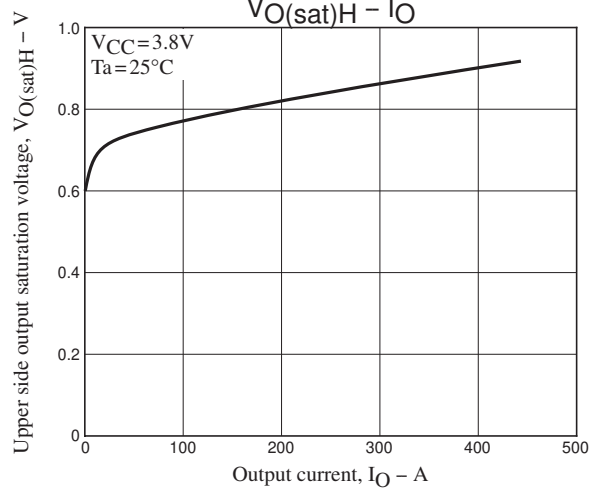
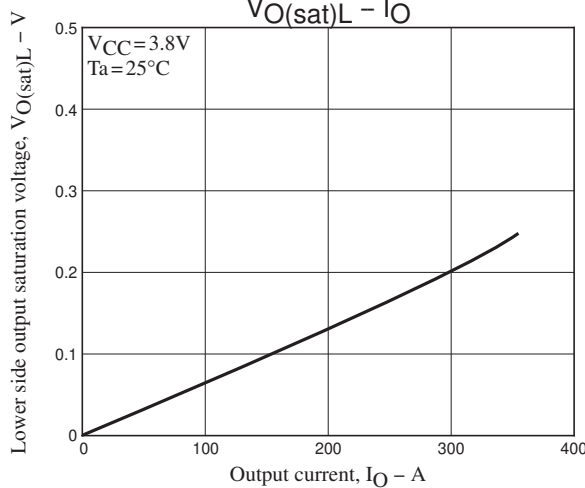
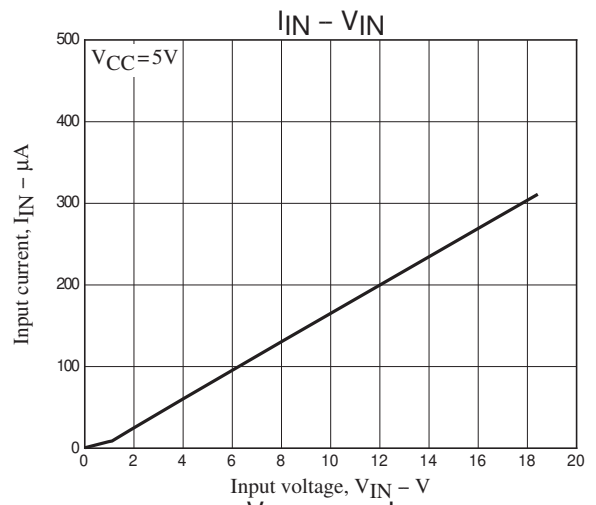
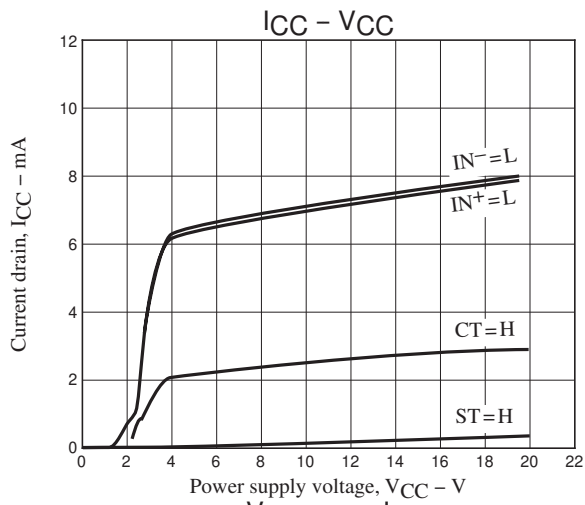
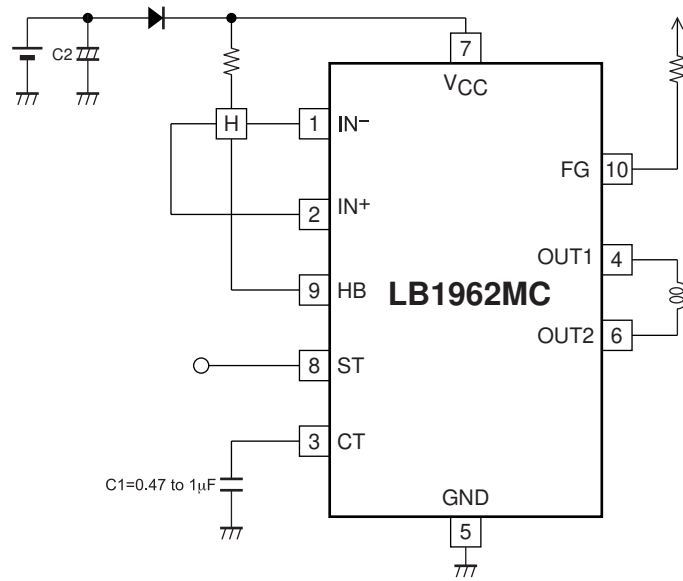

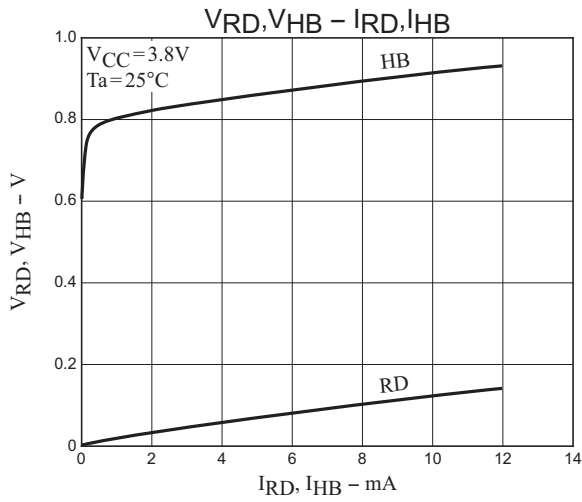

ON Semiconductor and the ON logo are registered trademarks of Semiconductor Components Industries, LLC (SCILLC). SCILLC owns the rights to a number of patents, trademarks, copyrights, trade secrets, and other intellectual property. A listing of SCILLC's product/patent coverage may be accessed at [www.onsemi.com/site/pdf/Patent-Marking.pdf](http://www.onsemi.com/site/pdf/Patent-Marking.pdf). SCILLC reserves the right to make changes without further notice to any products herein. SCILLC makes no warranty, representation or guarantee regarding the suitability of its products for any particular purpose, nor does SCILLC assume any liability arising out of the application or use of any product or circuit, and specifically disclaims any and all liability, including without limitation special, consequential or incidental damages. "Typical" parameters which may be provided in SCILLC data sheets and/or specifications can and do vary in different applications and actual performance may vary over time. All operating parameters, including "Typicals" must be validated for each customer application by customer's technical experts. SCILLC does not convey any license under its patent rights nor the rights of others. SCILLC products are not designed, intended, or authorized for use as components in systems intended for surgical implant into the body, or other applications intended to support or sustain life, or for any other application in which the failure of the SCILLC product could create a situation where personal injury or death may occur. Should Buyer purchase or use SCILLC products for any such unintended or unauthorized application, Buyer shall indemnify and hold SCILLC and its officers, employees, subsidiaries, affiliates, and distributors harmless against all claims, costs, damages, and expenses, and reasonable attorney fees arising out of, directly or indirectly, any claim of personal injury or death associated with such unintended or unauthorized use, even if such claim alleges that SCILLC was negligent regarding the design or manufacture of the part. SCILLC is an Equal Opportunity/Affirmative Action Employer. This literature is subject to all applicable copyright laws and is not for resale in any manner.