



Chipsmall Limited consists of a professional team with an average of over 10 year of expertise in the distribution of electronic components. Based in Hongkong, we have already established firm and mutual-benefit business relationships with customers from,Europe,America and south Asia,supplying obsolete and hard-to-find components to meet their specific needs.

With the principle of “Quality Parts,Customers Priority,Honest Operation,and Considerate Service”,our business mainly focus on the distribution of electronic components. Line cards we deal with include Microchip,ALPS,ROHM,Xilinx,Pulse,ON,Everlight and Freescale. Main products comprise IC,Modules,Potentiometer,IC Socket,Relay,Connector.Our parts cover such applications as commercial,industrial, and automotives areas.

We are looking forward to setting up business relationship with you and hope to provide you with the best service and solution. Let us make a better world for our industry!



## Contact us

Tel: +86-755-8981 8866 Fax: +86-755-8427 6832

Email & Skype: info@chipsmall.com Web: www.chipsmall.com

Address: A1208, Overseas Decoration Building, #122 Zhenhua RD., Futian, Shenzhen, China



# VALVE-REGULATED LEAD ACID BATTERIES: INDIVIDUAL DATA SHEET

## LC-P127R2P



For standby power supplies. Expected trickle life: Approx. 6 years at 25°C, Approx. 10 years at 20°C.

### Dimensions (mm)

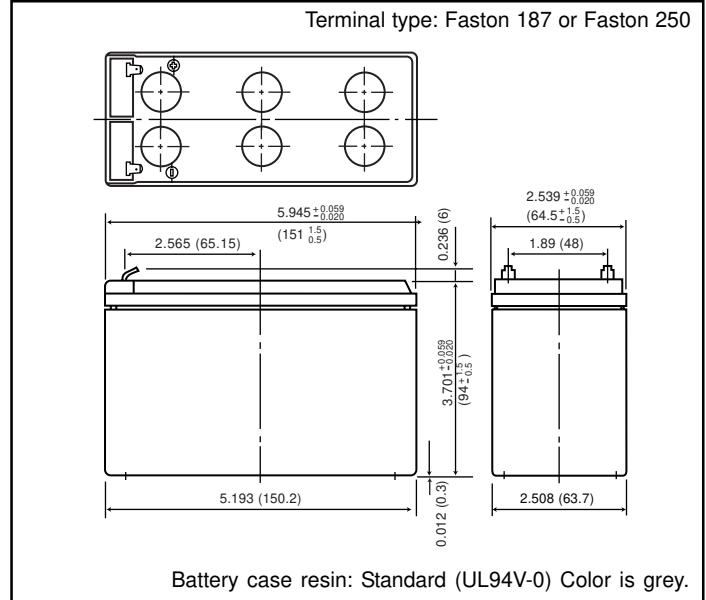

### Specifications

<b>Nominal Voltage</b>		12V
<b>Rated capacity (20 hour rate)</b>		7.2Ah
<b>Dimensions</b>	<b>Length</b>	5.945 inches (151.0 mm)
	<b>Width</b>	2.539 inches (64.5 mm)
	<b>Height</b>	3.702 inches (94.0 mm)
	<b>Total Height*</b>	3.937 inches (100.0 mm)
<b>Approx. mass</b>		5.516 lbs. (2.50 kg)
<b>Standard Terminals and Resin</b>	UL94V-0 Faston 250	LC-P127R2P1
<b>Optional Terminals and Resin</b>	UL94V-0 Faston 187	◆ LC-P127R2P

\* The total height with #250 terminal is 101.5mm.

◆ Please contact Panasonic for availability on optional items. Optional items may be subject to minimum order quantities.

### Discharge characteristics 77°F (25°C) (Note)

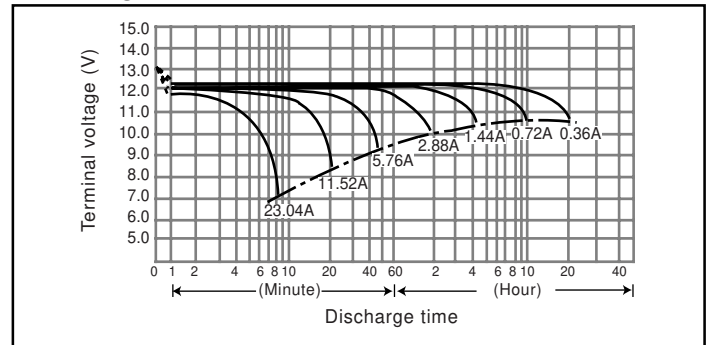

### Characteristics

Capacity (note) 77°F (25°C)	20 hour rate (360mA)	7.2Ah	
	10 hour rate (680mA)	6.8Ah	
	5 hour rate (1260mA)	6.3Ah	
	1 hour rate (4900mA)	4.9Ah	
	1.5 hour rate discharge Cut-off voltage 10.5 V	3.5A	
Internal Resistance	Fully charged battery 77°F (25°C)	Approx. 40mΩ	
Temperature dependency of capacity (20 hour rate)	104°F (40°C)	102%	
	77°F (25°C)	100%	
	32°F (0°C)	85%	
	5°F (-15°C)	65%	
Self discharge 77°F (25°C)	Residual capacity after standing 3 months	91%	
	Residual capacity after standing 6 months	82%	
	Residual capacity after standing 12 months	64%	
	Initial current	1.08 A or smaller	
Charge Method (Constant Voltage)	Trickle use	Control voltage	13.6V to 13.8V (per 12V cell 25°C)

(Note) The above characteristics data are average values obtained within three charge/discharge. Cycles not the minimum values.

(Note) For cycle use of the battery, please contact us in advance.

### Duration of discharge vs. Discharge current (Note)

