



Chipsmall Limited consists of a professional team with an average of over 10 year of expertise in the distribution of electronic components. Based in Hongkong, we have already established firm and mutual-benefit business relationships with customers from,Europe,America and south Asia,supplying obsolete and hard-to-find components to meet their specific needs.

With the principle of "Quality Parts,Customers Priority,Honest Operation,and Considerate Service",our business mainly focus on the distribution of electronic components. Line cards we deal with include Microchip,ALPS,ROHM,Xilinx,Pulse,ON,Everlight and Freescale. Main products comprise IC,Modules,Potentiometer,IC Socket,Relay,Connector.Our parts cover such applications as commercial,industrial, and automotives areas.

We are looking forward to setting up business relationship with you and hope to provide you with the best service and solution. Let us make a better world for our industry!



## Contact us

Tel: +86-755-8981 8866 Fax: +86-755-8427 6832

Email & Skype: info@chipsmall.com Web: www.chipsmall.com

Address: A1208, Overseas Decoration Building, #122 Zhenhua RD., Futian, Shenzhen, China





**ON Semiconductor®**

<http://onsemi.com>

# LC749402PT

---

CMOS IC

## Silicon gate LCD Picture Quality Improvement IC

### Overview

LC749402PT is a picture quality improvement IC that processes the output signals to the LCD panel for high picture quality display. This IC performs various picture quality adjustments to provide the ideal correction for the display panel.

It can support up to WVGA/SVGA panels. \*

### Features

(1) Digital input/output

- Digital YCbCr/YPbPr 24bit (4:4:4) or 16bit (4:2:2) or 8bit (ITU-R BT.656) signal input
- Digital RGB 24bit signal input
- Digital RGB 18bit/24bit signal output
- Digital YCbCr 16bit (4:2:2)/24bit (4:4:4) signal output

(2) Image quality correction

- Y image quality correction: luminance adjustment, contour correction, CDEX (Color Depth Expander), dynamic- $\gamma$ , black/white stretch
- C image quality correction: color exciter, flesh tone correction, hue, color gain
- RGB image quality correction: brightness, contrast, white balance, black balance,  $\gamma$  correction

(3) Panel interface

- Built-in panel driver timing controller
- Panel protection timing signal generation
- Backlight control PWM (video adaptive low power consumption processing)

\*: The LC749402PT video input should satisfy the following conditions:

40MHz or less operating frequency, 896 dots or less horizontal size, 768 lines or less vertical size.

## LSI Specifications

- Supply voltage Core: 1.2V  
I/O: 1.8V/2.85V/3.3V
- Maximum operating frequency: 40MHz
- Package: TQFP100

## Principal Applications

- LCD display equipment

## CDEX (Color Depth Expander)



Original



CDEX

## Specifications

**Absolute Maximum Ratings** at  $T_a = 25^\circ\text{C}$ ,  $DV_{SS} = 0\text{V}$ ,  $AV_{SS\_OSC} = 0\text{V}$

Parameter	Symbol	Conditions	Ratings	Unit
Maximum supply voltage (I/O)	$DV_{DD\_IO}$		-0.3 to +3.96	V
Maximum supply voltage (core)	$DV_{DD\_CORE}$ $AV_{DD\_OSC}$		-0.3 to +1.8	V
Digital input voltage	$V_I$		-0.3 to $DV_{DD\_IO}+0.3$	V
Digital output voltage	$V_O$		-0.3 to $DV_{DD\_IO}+0.3$	V
Operating temperature	$T_{opr}$		-40 to +85	$^\circ\text{C}$
Storage temperature	$T_{stg}$		-55 to +125	$^\circ\text{C}$

Stresses exceeding Maximum Ratings may damage the device. Maximum Ratings are stress ratings only. Functional operation above the Recommended Operating Conditions is not implied. Extended exposure to stresses above the Recommended Operating Conditions may affect device reliability.

**Allowable Operating Ranges** at  $T_a = -40$  to  $+85^\circ\text{C}$ ,  $DV_{SS} = 0\text{V}$ ,  $AV_{SS\_OSC} = 0\text{V}$

Parameter	Symbol	Conditions	Ratings			unit
			min	typ	max	
Supply voltage (I/O)	$DV_{DD\_IO}$		2.6	2.85	3.6	V
			1.7	1.8	1.9	V
Supply voltage (core)	$DV_{DD\_CORE}$ $AV_{DD\_OSC}$		1.1	1.2	1.3	V
Input voltage range	$V_{IN}$		0		$DV_{DD\_IO}$	V

# LC749402PT

**DC Characteristics** at  $T_a = -40$  to  $+85^\circ\text{C}$ ,  $DV_{SS} = 0\text{V}$ ,  $AV_{SS\_OSC} = 0\text{V}$ ,

$DV_{DD\_IO} = 1.7\text{V}$  to  $1.9\text{V}$  or  $2.6\text{V}$  to  $3.6\text{V}$ ,  $DV_{DD\_CORE} = 1.1\text{V}$  to  $1.3\text{V}$

Parameter	Symbol	Conditions	Ratings			unit
			min	typ	max	
Input high-level voltage	$V_{IH}$	CMOS level inputs	$0.7DV_{DD\_IO}$			V
		CMOS level schmitt inputs	$0.7DV_{DD\_IO}$			V
Input low-level voltage	$V_{IL}$	CMOS level inputs			$0.3DV_{DD\_IO}$	V
		CMOS level schmitt inputs			$0.3DV_{DD\_IO}$	V
Input high-level current	$I_{IH}$	$V_I = DV_{DD\_IO}$			10	$\mu\text{A}$
		$V_I = DV_{DD\_IO}$ , with pull-down resistance			100	$\mu\text{A}$
Input low-level current	$I_{IL}$	$V_I = DV_{SS}$	-10			$\mu\text{A}$
Output high-level voltage	$V_{OH}$	CMOS voltage: 2.6V to 3.6V Pin D: $I_{OH} = -2\text{mA}$ Pin F: $I_{OH} = -2\text{mA}$ (when set to 2mA) $I_{OH} = -4\text{mA}$ (when set to 4mA) Pin G: $I_{OH} = -4\text{mA}$ (when set to 4mA) $I_{OH} = -8\text{mA}$ (when set to 8mA) Pin H: $I_{OH} = -4\text{mA}$	$DV_{DD\_IO} - 0.4$			V
		CMOS voltage: 1.7V to 1.9V Pin D: $I_{OH} = -1\text{mA}$ Pin F: $I_{OH} = -1\text{mA}$ (when set to 2mA) $I_{OH} = -2\text{mA}$ (when set to 4mA) Pin G: $I_{OH} = -2\text{mA}$ (when set to 4mA) $I_{OH} = -4\text{mA}$ (when set to 8mA) Pin H: $I_{OH} = -2\text{mA}$	$DV_{DD\_IO} - 0.45$			V
Output low-level voltage	$V_{OL}$	CMOS			0.4	V
Output leak current	$I_{OZ}$	At output of high-impedance	-10		10	$\mu\text{A}$
Pull-down resistor	$R_{DN}$	Typical conditions: $T_a = 25^\circ\text{C}$ $DV_{DD\_IO} = 2.85\text{V}$ $DV_{DD\_CORE} = 1.2\text{V}$		98		k $\Omega$
Dynamic supply current	$I_{DDOP}$	Typical conditions: $T_a = 25^\circ\text{C}$ $DV_{DD\_IO} = 2.85\text{V}$ $DV_{DD\_CORE} = 1.2\text{V}$ tck=10MHz 10 steps		18		mA
		Typical conditions: $T_a = 25^\circ\text{C}$ $DV_{DD\_IO} = 2.85\text{V}$ $DV_{DD\_CORE} = 1.2\text{V}$ tck=40MHz 10 steps		57		mA
Static supply current *1	$I_{DDST}$	Typical conditions: $T_a = 25^\circ\text{C}$ $DV_{DD\_IO} = 2.85\text{V}$ $DV_{DD\_CORE} = 1.2\text{V}$ Outputs open $V_I = DV_{SS}$ or $DV_{DD\_IO}$		20		$\mu\text{A}$

\*1: There is a input terminal which builds in pull down resistance. Please note that there is no guarantee about static consumption current depending on circuit composition.

# LC749402PT

## Package Dimensions

unit:mm (typ)

3274

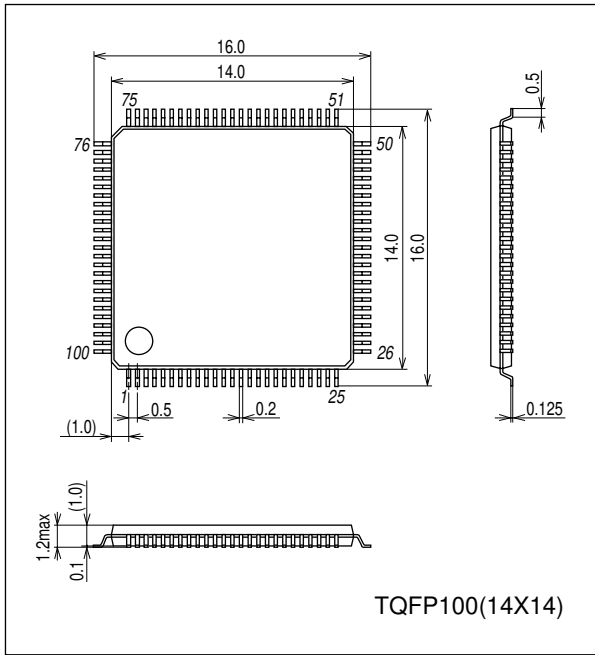

## Pin Assignment

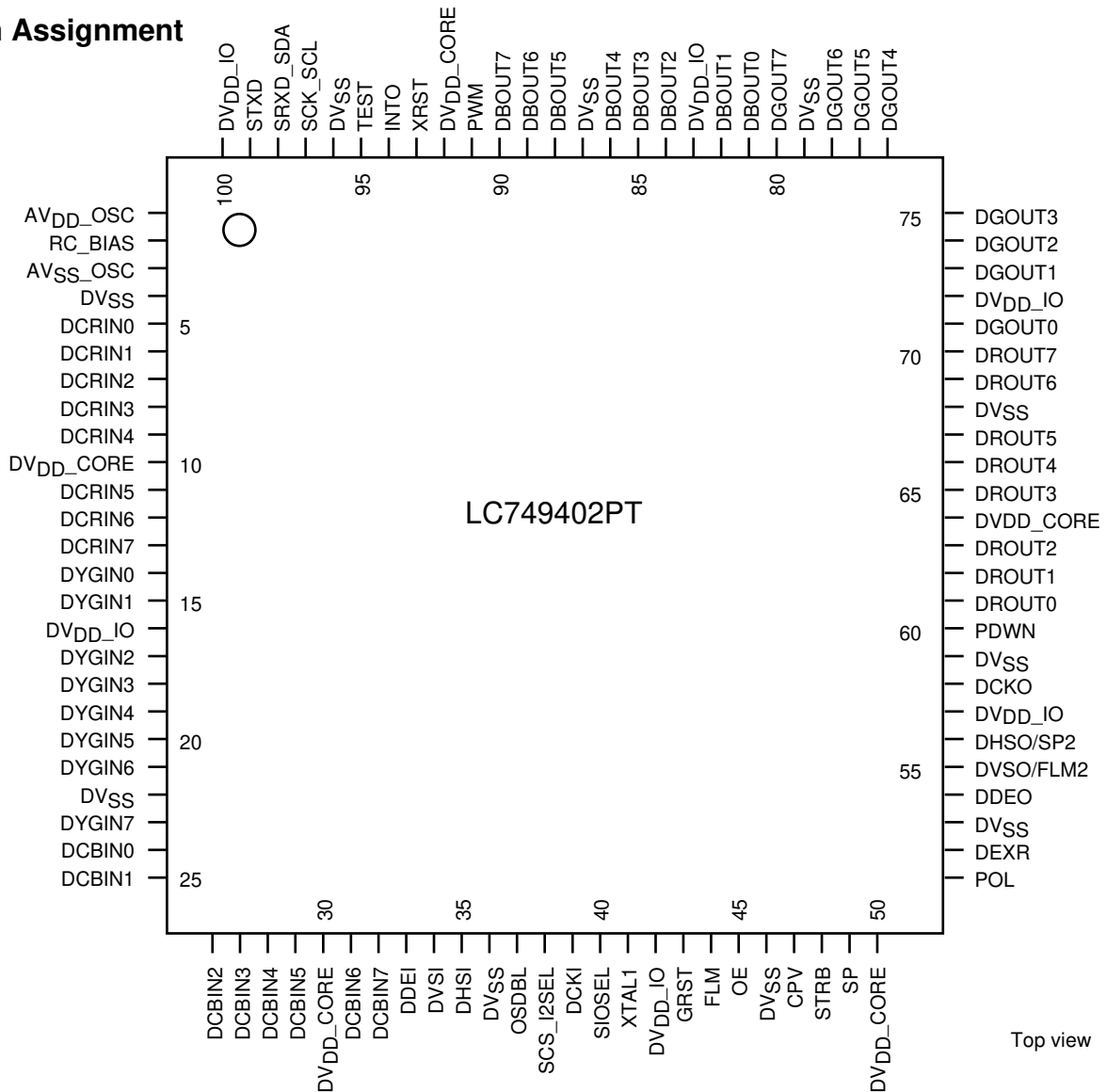

Top view

Block Diagram

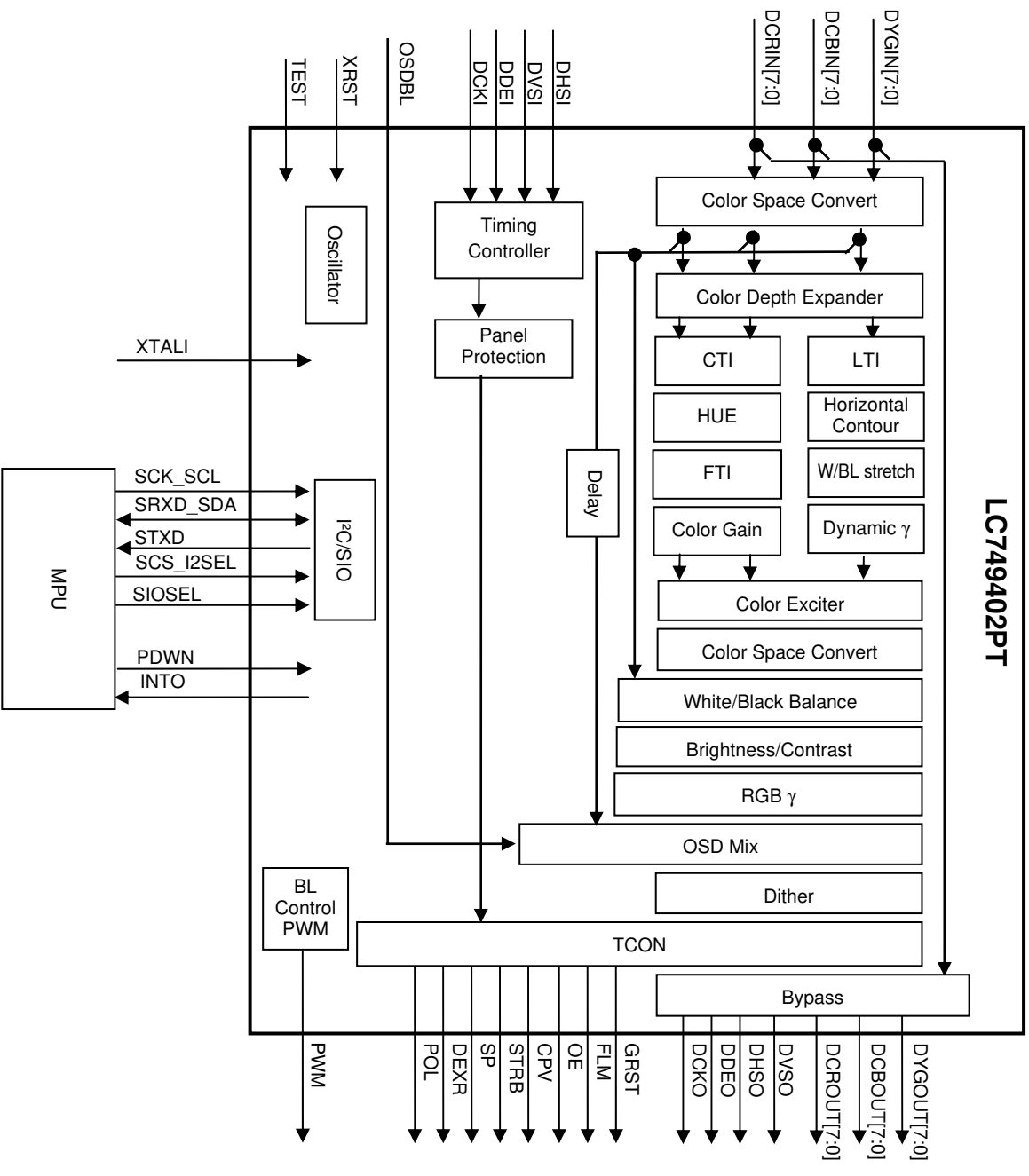

# LC749402PT

## Pin Functions

Pin No.	Pin symbol	In/output format		Connecting destination		Remarks
		I/O	Format			
1	AV <sub>DD</sub> _OSC	P	-	Core Voltage	Analog	
2	RC_BIAS	I	J	Resistor	Analog	Bias resistor connection (Connect to ground through 20kΩ resistor)
3	AV <sub>SS</sub> _OSC	P	-	GND	Analog	
4	DV <sub>SS</sub>	P	-	GND	Digital	
5	DCRIN0	I	C	CMOS	Digital	R/Cr video input. (LSB Connect to GND when not used.)
6	DCRIN1	I	C	CMOS	Digital	R/Cr video input. (Connect to GND when not used.)
7	DCRIN2	I	C	CMOS	Digital	R/Cr video input (Connect to GND when not used.)
8	DCRIN3	I	C	CMOS	Digital	R/Cr video input (Connect to GND when not used.)
9	DCRIN4	I	C	CMOS	Digital	R/Cr video input (Connect to GND when not used.)
10	DV <sub>DD</sub> _CORE	P	-	Core Voltage	Digital	
11	DCRIN5	I	C	CMOS	Digital	R/Cr video input (Connect to GND when not used.)
12	DCRIN6	I	C	CMOS	Digital	R/Cr video input (Connect to GND when not used.)
13	DCRIN7	I	C	CMOS	Digital	R/Cr video input (MSB Connect to GND when not used.)
14	DYGIN0	I	C	CMOS	Digital	G/Y/656 video input (LSB Connect to GND when not used.)
15	DYGIN1	I	C	CMOS	Digital	G/Y/656 video input (Connect to GND when not used.)
16	DV <sub>DD</sub> _IO	P	-	IO voltage	Digital	
17	DYGIN2	I	C	CMOS	Digital	G/Y/656 video input (Connect to GND when not used.)
18	DYGIN3	I	C	CMOS	Digital	G/Y/656 video input (Connect to GND when not used.)
19	DYGIN4	I	C	CMOS	Digital	G/Y/656 video input (Connect to GND when not used.)
20	DYGIN5	I	C	CMOS	Digital	G/Y/656 video input (Connect to GND when not used.)
21	DYGIN6	I	C	CMOS	Digital	G/Y/656 video input (Connect to GND when not used.)
22	DV <sub>SS</sub>	P	-	GND	Digital	
23	DYGIN7	I	C	CMOS	Digital	G/Y/656 video input (MSB Connect to GND when not used.)
24	DCBIN0	I	C	CMOS	Digital	B/Cb/C video (LSB Connect to GND when not used.)
25	DCBIN1	I	C	CMOS	Digital	B/Cb/C video input (Connect to GND when not used.)
26	DCBIN2	I	C	CMOS	Digital	B/Cb/C video input (Connect to GND when not used.)
27	DCBIN3	I	C	CMOS	Digital	B/Cb/C video input (Connect to GND when not used.)
28	DCBIN4	I	C	CMOS	Digital	B/Cb/C video input (Connect to GND when not used.)
29	DCBIN5	I	C	CMOS	Digital	B/Cb/C video input (Connect to GND when not used.)
30	DV <sub>DD</sub> _CORE	P	-	Core Voltage	Digital	
31	DCBIN6	I	C	CMOS	Digital	B/Cb/C video input (Connect to GND when not used.)
32	DCBIN7	I	C	CMOS	Digital	B/Cb/C video input (MSB Connect to GND when not used.)
33	DDEI	I	C	CMOS	Digital	Data enable signal. (Connect to GND when not used.)
34	DVSI	I	C	CMOS	Digital	Vertical sync signal
35	DHSI	I	C	CMOS	Digital	Horizontal sync signal.
36	DV <sub>SS</sub>	P	-	GND	Digital	
37	OSDBL	I	C	CMOS	Digital	Data enable signal for external OSD. (Connect to GND when not used.)
38	SCS_I2SEL	I	A	CMOS	Digital	SIO chip enable / I <sup>2</sup> C slave select
39	DCKI	I	C	CMOS	Digital	Video clock.
40	SIOSEL	I	C	CMOS	Digital	"L": I <sup>2</sup> C slave, "H": 4 wire SIO
41	XTAL1	I	C	CMOS	Digital	External clock input for panel protection. (Connect to GND when not used.)
42	DV <sub>DD</sub> _IO	P	-	IO voltage	Digital	
43	GRST	O	F	CMOS	Digital	Gate driver reset signal.
44	FLM	O	F	CMOS	Digital	Start pulse signal for gate driver
45	OE	O	F	CMOS	Digital	Output enable signal for gate driver.
46	DV <sub>SS</sub>	P	-	GND	Digital	
47	CPV	O	F	CMOS	Digital	Gate driver clock signal.
48	STRB	O	F	CMOS	Digital	Data strobe signal for source driver.
49	SP	O	F	CMOS	Digital	Start pulse signal for source driver.

Continued on next page.

# LC749402PT

Continued from preceding page.

Pin No.	Pin symbol	In/output format		Connecting destination		Remarks
		I/O	Format			
50	DV <sub>DD</sub> _CORE	P	-	Core Voltage	Digital	
51	POL	O	F	CMOS	Digital	Voltage polarity selection signal for the source driver.
52	DEXR	O	F	CMOS	Digital	Reversed video signal output for DTR. Low output when the DTR is OFF.
53	DV <sub>SS</sub>	P	-	GND	Digital	
54	DDEO	O	F	CMOS	Digital	Data enable signal
55	DVSO / FLM2	O	F	CMOS	Digital	Vertical sync signal / Start pulse signal for gate driver
56	DHSO / SP2	O	F	CMOS	Digital	Horizontal sync signal / Start pulse signal for source driver
57	DV <sub>DD</sub> _IO	P	-	IO voltage	Digital	
58	DCKO	O	G	CMOS	Digital	Video clock output
59	DV <sub>SS</sub>	P	-	GND	Digital	
60	PDWN	I	A	CMOS	Digital	"H" power down control (Connect to GND when not used.)
61	DROUT0	O	F	CMOS	Digital	R/Cr video output (LSB when 8-bit output is selected)
62	DROUT1	O	F	CMOS	Digital	R/Cr video output
63	DROUT2	O	F	CMOS	Digital	R/Cr video output (LSB when 6-bit output is selected)
64	DV <sub>DD</sub> _CORE	P	-	Core Voltage	Digital	
65	DROUT3	O	F	CMOS	Digital	R/Cr video output
66	DROUT4	O	F	CMOS	Digital	R/Cr video output
67	DROUT5	O	F	CMOS	Digital	R/Cr video output
68	DV <sub>SS</sub>	P	-	GND	Digital	
69	DROUT6	O	F	CMOS	Digital	R/Cr video output
70	DROUT7	O	F	CMOS	Digital	R/Cr video output (MSB)
71	DGOUT0	O	F	CMOS	Digital	G/Y video output (LSB when 8-bit output is selected)
72	DV <sub>DD</sub> _IO	P	-	IO voltage	Digital	
73	DGOUT1	O	F	CMOS	Digital	G/Y video output
74	DGOUT2	O	F	CMOS	Digital	G/Y video output (LSB when 6-bit output is selected)
75	DGOUT3	O	F	CMOS	Digital	G/Y video output
76	DGOUT4	O	F	CMOS	Digital	G/Y video output
77	DGOUT5	O	F	CMOS	Digital	G/Y video output
78	DGOUT6	O	F	CMOS	Digital	G/Y video output
79	DV <sub>SS</sub>	P	-	GND	Digital	
80	DGOUT7	O	F	CMOS	Digital	G/Y video output (MSB)
81	DBOUT0	O	F	CMOS	Digital	B/Cb/C video output (LSB when 8-bit output is selected)
82	DBOUT1	O	F	CMOS	Digital	B/Cb/C video output
83	DV <sub>DD</sub> _IO	P	-	IO voltage	Digital	
84	DBOUT2	O	F	CMOS	Digital	B/Cb/C video output (LSB when 6-bit output is selected)
85	DBOUT3	O	F	CMOS	Digital	B/Cb/C video output
86	DBOUT4	O	F	CMOS	Digital	B/Cb/C video output
87	DV <sub>SS</sub>	P	-	GND	Digital	
88	DBOUT5	O	F	CMOS	Digital	B/Cb/C video output
89	DBOUT6	O	F	CMOS	Digital	B/Cb/C video output
90	DBOUT7	O	F	CMOS	Digital	B/Cb/C video output (MSB)
91	PWM	O	D	CMOS	Digital	Pulse width modulation waveform output
92	DV <sub>DD</sub> _CORE	P	-	Core Voltage	Digital	
93	XRST	I	A	CMOS	Digital	System reset ("L" reset)
94	INTO	O	D	CMOS	Digital	Interrupt
95	TEST	I	B	CMOS	Digital	Test setting (Connect to GND normally)
96	DV <sub>SS</sub>	P	-	GND	Digital	
97	SCK_SCL	I	C	CMOS	Digital	Bus clock (shared with SIO/I <sup>2</sup> C)
98	SRXD_SDA	I/O	H	CMOS	Digital	SIO data input / I <sup>2</sup> C data input/output
99	STXD	O	D	CMOS	Digital	SIO data
100	DV <sub>DD</sub> _IO	P	-	IO voltage	Digital	



# LC749402PT

## Pin Type

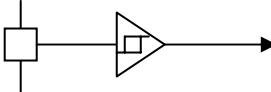
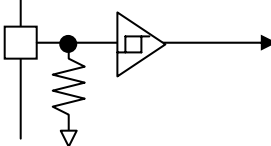
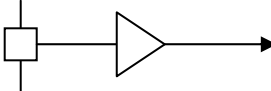
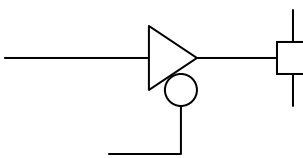
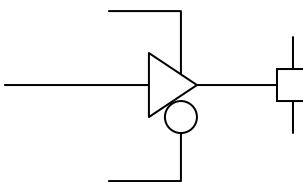
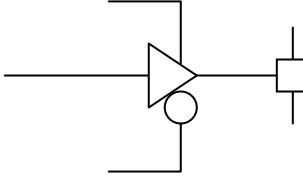
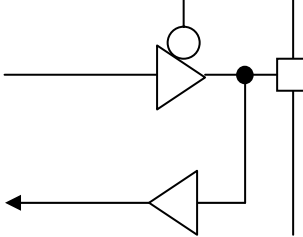
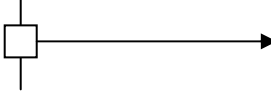
In/Output form	Function	Equivalent circuit	Application Terminal
A	Schmitt trigger CMOS input		XRST, PDWN, SCS_I2SEL
B	CMOS input with built-in pull-down resistor		TEST
C	CMOS input		SCK_SCL, SIOSEL, DVSI, DHSI, DDEI, OSDBL, DYGIN7, DYGIN6, DYGIN5, DYGIN4, DYGIN3, DYGIN2, DYGIN1, DYGIN0, DCBIN7, DCBIN6, DCBIN5, DCBIN4, DCBIN3, DCBIN2, DCBIN1, DCBIN0, DCRIN7, DCRIN6, DCRIN5, DCRIN4, DCRIN3, DCRIN2, DCRIN1, DCRIN0
D	2mA 3-STATE drive CMOS output		STXD, PWM, INTO
F	2mA/4mA switching 3-STATE drive CMOS output		DBOUT7, DBOUT6, DBOUT5, DBOUT4, DBOUT3, DBOUT2, DBOUT1, DBOUT0, DROUT7, DROUT6, DROUT5, DROUT4, DROUT3, DROUT2, DROUT1, DROUT0 DGOUT7, DGOUT6, DGOUT5, DGOUT4, DGOUT3, DGOUT2, DGOUT1, DGOUT0, DHSO/SP2, DVSO/FLM2, DDEO FLM, DEXR, POL, GRST, CPV, SP, OE, STRB
G	4mA/8mA switching 3-STATE drive CMOS output		DCKO
H	4mA 3-STATE drive CMOS input/output		SRXD_SDA
J	Analog input/output		RC_BIAS

# LC749402PT

## I/O Timing

### (1) Input data timing

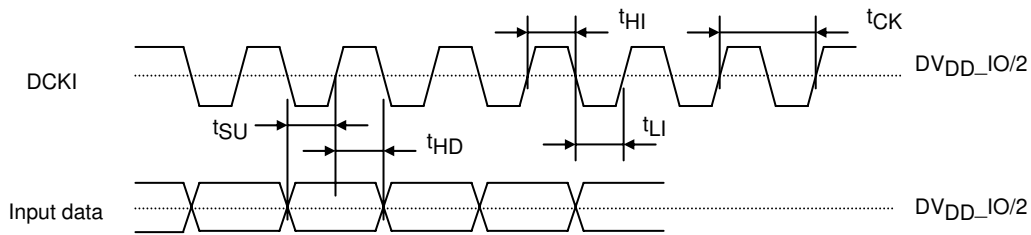

Pin name	Parameter	Symbol	min	typ	max	unit
DCKI	Clock cycle	tCK	25			ns
	Duty			50		%
DCRIN*, DYGIN*, DCBIN*, DVSI, DHSI, DDEI, OSDBL	Input data setup time (DVDD_IO=2.6 to 3.6V)	tSU	3			ns
	Input data setup time (DVDD_IO=1.7 to 1.9V)	tSU	3			ns
	Input data hold time (DVDD_IO=2.6 to 3.6V)	tHD	2			ns
	Input data hold time (DVDD_IO=1.7 to 1.9V)	tHD	2			ns

\*: The recommended duty cycle of input clock is 50%

### (2) Output data timing

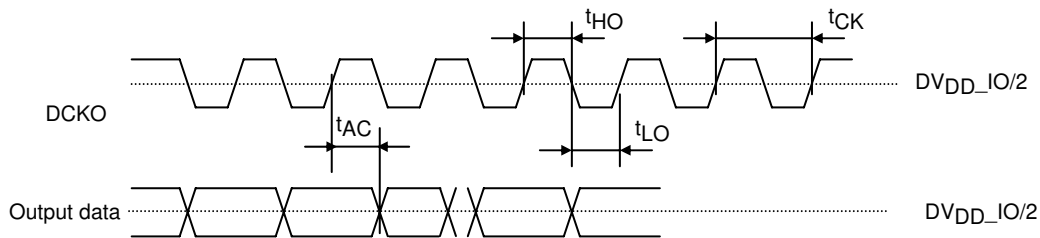

Pin name	Parameter	Symbol	min	typ	max	unit
DCKO	Clock cycle	tCK	25			ns
	Duty			50		%
DROUT*, DGOUT*, DBOUT*, DVSO, DHSO, DDEO, DEXR, POL, SP, STRB, CPV, OE, FLM, GRST	Output data delay time (DVDD_IO=2.6 to 3.6V) Pin F: when set to 4mA Pin G: when set to 8mA	tAC	-3		3	ns
	Output data delay time (DVDD_IO=2.6 to 3.6V) Pin F: when set to 2mA Pin G: when set to 4mA	tAC	-3		6	ns
	Output data delay time (DVDD_IO=1.7 to 1.9V) Pin F: when set to 4mA Pin G: when set to 8mA	tAC	-5		4	ns
	Output data delay time (DVDD_IO=1.7 to 1.9V) Pin F: when set to 2mA Pin G: when set to 4mA	tAC	-6		9	ns

\* When DCKO is set to the forward rotation output. Output load capacity: 5pF

ON Semiconductor and the ON logo are registered trademarks of Semiconductor Components Industries, LLC (SCILLC). SCILLC owns the rights to a number of patents, trademarks, copyrights, trade secrets, and other intellectual property. A listing of SCILLC's product/patent coverage may be accessed at [www.onsemi.com/site/pdf/Patent-Marking.pdf](http://www.onsemi.com/site/pdf/Patent-Marking.pdf). SCILLC reserves the right to make changes without further notice to any products herein. SCILLC makes no warranty, representation or guarantee regarding the suitability of its products for any particular purpose, nor does SCILLC assume any liability arising out of the application or use of any product or circuit, and specifically disclaims any and all liability, including without limitation special, consequential or incidental damages. "Typical" parameters which may be provided in SCILLC data sheets and/or specifications can and do vary in different applications and actual performance may vary over time. All operating parameters, including "Typicals" must be validated for each customer application by customer's technical experts. SCILLC does not convey any license under its patent rights nor the rights of others. SCILLC products are not designed, intended, or authorized for use as components in systems intended for surgical implant into the body, or other applications intended to support or sustain life, or for any other application in which the failure of the SCILLC product could create a situation where personal injury or death may occur. Should Buyer purchase or use SCILLC products for any such unintended or unauthorized application, Buyer shall indemnify and hold SCILLC and its officers, employees, subsidiaries, affiliates, and distributors harmless against all claims, costs, damages, and expenses, and reasonable attorney fees arising out of, directly or indirectly, any claim of personal injury or death associated with such unintended or unauthorized use, even if such claim alleges that SCILLC was negligent regarding the design or manufacture of the part. SCILLC is an Equal Opportunity/Affirmative Action Employer. This literature is subject to all applicable copyright laws and is not for resale in any manner.