



Chipsmall Limited consists of a professional team with an average of over 10 year of expertise in the distribution of electronic components. Based in Hongkong, we have already established firm and mutual-benefit business relationships with customers from,Europe,America and south Asia,supplying obsolete and hard-to-find components to meet their specific needs.

With the principle of “Quality Parts,Customers Priority,Honest Operation,and Considerate Service”,our business mainly focus on the distribution of electronic components. Line cards we deal with include Microchip,ALPS,ROHM,Xilinx,Pulse,ON,Everlight and Freescale. Main products comprise IC,Modules,Potentiometer,IC Socket,Relay,Connector.Our parts cover such applications as commercial,industrial, and automotives areas.

We are looking forward to setting up business relationship with you and hope to provide you with the best service and solution. Let us make a better world for our industry!



Contact us

Tel: +86-755-8981 8866 Fax: +86-755-8427 6832

Email & Skype: info@chipsmall.com Web: www.chipsmall.com

Address: A1208, Overseas Decoration Building, #122 Zhenhua RD., Futian, Shenzhen, China



LC75805PE

1/1 to 1/4 Duty General-Purpose LCD Driver with LED Driver



ON Semiconductor®

www.onsemi.com

Overview

LC75805PE is the 1/1 to 1/4 duty general-purpose LCD display driver with the LED driver to use for the instrument panel display by control with the controller. In addition, LC75805PE is able to drive up to 48 LED and LCD of up to 140 segments directly, and has a built-in 7ch PWM function for brightness adjustment of LED. Furthermore, because of built-in the oscillator circuit, it is possible to reduce external resistor and capacitor for oscillation.

Features

- Switch of Static Drive, 1/2 Duty Drive, 1/3 Duty Drive and 1/4 Duty Drive can be controlled by serial data.
 - Static Drive (1/1 Duty Drive) : Capable of driving up to 38 segments.
 - 1/2 Duty Drive : Capable of driving up to 74 segments.
 - 1/3 Duty Drive : Capable of driving up to 108 segments.
 - 1/4 Duty Drive : Capable of driving up to 140 segments.
- Frame frequency of common and segment output waveform can be controlled by serial data.
- Turning on/off LED can be controlled by serial data.
(Capable of driving up to 48 LED)
- Built-in 7 ch PWM function for brightness adjustment of LED.
(Resolution of 128 steps)
- Frame frequency of LED driver output waveform can be controlled by serial data.
- Serial data input supports CCB* format communication with the system controller. (Support 5 V operation)
- Backup function and forced turning off all segments by power-saving mode can be controlled by serial data.
- Switch of the internal oscillator operating mode and the external clock operating mode can be controlled by serial data.
- High generality, since display data is displayed directly without the intervention of a decoder circuit.
- The INH pin allows the display to be forced to the off state.
- Built-in Oscillator circuit (Built-in resistor and capacitor for oscillation)

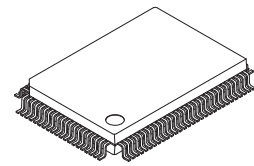

PQFP100 14x20 / QIP100E

* Computer Control Bus (CCB) is an ON Semiconductor's original bus format and the bus addresses are controlled by ON Semiconductor.

ORDERING INFORMATION

See detailed ordering and shipping information on page 34 of this data sheet.

LC75805PE

Specifications

Absolute Maximum Ratings at $T_a = 25^\circ\text{C}$, $V_{SS} = 0\text{ V}$

Parameter	Symbol	Conditions	Ratings	Unit
Maximum supply voltage	$V_{DD\text{ max}}$	V_{DD}	-0.3 to +6.5	V
Input voltage	V_{IN1}	CE, CL, DI, $\overline{\text{INH}}$, OSCI	-0.3 to +6.5	V
Output voltage	V_{OUT1}	S1 to S38, COM1 to COM4	-0.3 to $V_{DD}+0.3$	V
	V_{OUT2}	LD1 to LD48	-0.3 to +35	
Output current	I_{OUT1}	S1 to S38	300	μA
	I_{OUT2}	COM1 to COM4	3	mA
	I_{OUT3}	LD1 to LD48	30	
Allowable power dissipation	$P_{d\text{ max}}$	$T_a = 95^\circ\text{C}$	400	mW
Operating temperature	T_{opr}		-40 to +95	$^\circ\text{C}$
Storage temperature	T_{stg}		-55 to +150	$^\circ\text{C}$

Stresses exceeding those listed in the Maximum Ratings table may damage the device. If any of these limits are exceeded, device functionality should not be assumed, damage may occur and reliability may be affected.

Allowable Operating Ranges at $T_a = -40$ to $+95^\circ\text{C}$, $V_{SS} = 0\text{ V}$

Parameter	Symbol	Conditions	Ratings			Unit
			min	typ	max	
Supply voltage	V_{DD}	V_{DD}	4.5		5.5	V
Input high-level voltage	V_{IH1}	CE, CL, DI, $\overline{\text{INH}}$	$0.8V_{DD}$		5.5	V
	V_{IH2}	OSCI	$0.8V_{DD}$		5.5	
Input low-level voltage	V_{IL1}	CE, CL, DI, $\overline{\text{INH}}$	0		$0.2V_{DD}$	V
	V_{IL2}	OSCI	0		$0.2V_{DD}$	
Output pull-up voltage	V_{OUP}	LD1 to LD48, $V_{DD} = 4.5$ to 5.5 V	0		30	V
External clock operating frequency	f_{CK}	OSCI, External clock operating mode [Fig 3]	100	300	600	kHz
External clock duty	D_{CK}	OSCI, External clock operating mode [Fig 3]	30	50	70	%
Data setup time	t_{ds}	CL, DI [Fig 1], [Fig 2]	160			ns
Data hold time	t_{dh}	CL, DI [Fig 1], [Fig 2]	160			ns
CE wait time	t_{cp}	CE, CL [Fig 1], [Fig 2]	160			ns
CE setup time	t_{cs}	CE, CL [Fig 1], [Fig 2]	160			ns
CE hold time	t_{ch}	CE, CL [Fig 1], [Fig 2]	160			ns
High-level clock pulse width	$t_{\phi H}$	CL [Fig 1], [Fig 2]	160			ns
Low-level clock pulse width	$t_{\phi L}$	CL [Fig 1], [Fig 2]	160			ns
Rise time	t_r	CE, CL, DI [Fig 1], [Fig 2]		160		ns
Fall time	t_f	CE, CL, DI [Fig 1], [Fig 2]		160		ns
$\overline{\text{INH}}$ switching time	t_c	$\overline{\text{INH}}$, CE [Fig 4], [Fig 5], [Fig 6], [Fig 7]	10			μs

Functional operation above the stresses listed in the Recommended Operating Ranges is not implied. Extended exposure to stresses beyond the Recommended Operating Ranges limits may affect device reliability.

LC75805PE

Electrical Characteristics for the Allowable Operating Ranges

Parameter	Symbol	Pin	Conditions	Ratings			Unit
				min	typ	max	
Hysteresis	V _H	CE, CL, DI, $\overline{\text{INH}}$			0.1V _{DD}		V
Input high-level current	I _{IH1}	CE, CL, DI, $\overline{\text{INH}}$	V _I = 5.5 V			5.0	μA
	I _{IH2}	OSCI	V _I = 5.5 V			5.0	
Input low-level current	I _{IL1}	CE, CL, DI, $\overline{\text{INH}}$	V _I = 0 V	-5.0			μA
	I _{IL2}	OSCI	V _I = 0 V	-5.0			
Output OFF leak current	I _{OFFH}	LD1 to LD48	V _O = 30 V			5.0	μA
Output high-level voltage	V _{OH1}	S1 to S38	I _O = -20 μA	V _{DD} -0.9			V
	V _{OH2}	COM1 to COM4	I _O = -100 μA	V _{DD} -0.9			
Output low-level voltage	V _{OL1}	S1 to S38	I _O = 20 μA			0.9	V
	V _{OL2}	COM1 to COM4	I _O = 100 μA			0.9	
	V _{OL3}	LD1 to LD48	I _O = 20 mA		0.25	0.5	
Output middle-level voltage	V _{MID1}	S1 to S36	1/3 bias I _O = ±20 μA	2/3V _{DD} -0.9		2/3V _{DD} +0.9	V
	V _{MID2}	S1 to S36	1/3 bias I _O = ±20 μA	1/3V _{DD} -0.9		1/3V _{DD} +0.9	
	V _{MID3}	COM1 to COM4	1/3 bias I _O = ±100 μA	2/3V _{DD} -0.9		2/3V _{DD} +0.9	
	V _{MID4}	COM1 to COM4	1/3 bias I _O = ±100 μA	1/3V _{DD} -0.9		1/3V _{DD} +0.9	
	V _{MID5}	COM1, COM2	1/2 bias I _O = ±100 μA	1/2V _{DD} -0.9		1/2V _{DD} +0.9	
Oscillator frequency	f _{osc}	Oscillator circuit	Internal oscillator operating mode	240	300	360	kHz
Current drain	I _{DD1}	V _{DD}	Power save mode			15	μA
	I _{DD2}	V _{DD}	V _{DD} = 5.5 V Output open, Internal oscillator operating mode		750	1500	
	I _{DD3}	V _{DD}	V _{DD} = 5.5 V Output open, External clock operating mode f _{CK} = 300 kHz V _{IH2} = 0.9V _{DD} V _{IL2} = 0.1V _{DD}		750	1500	

* Electrical Characteristics might be changed for the improvement without notice.

Product parametric performance is indicated in the Electrical Characteristics for the listed test conditions, unless otherwise noted. Product performance may not be indicated by the Electrical Characteristics if operated under different conditions.

LC75805PE

1. When CL is stopped at the low level.

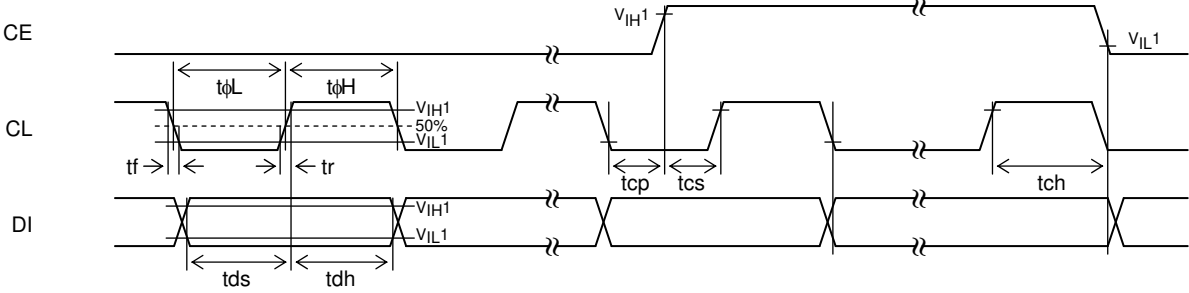

[Fig 1]

2. When CL is stopped at the high level.

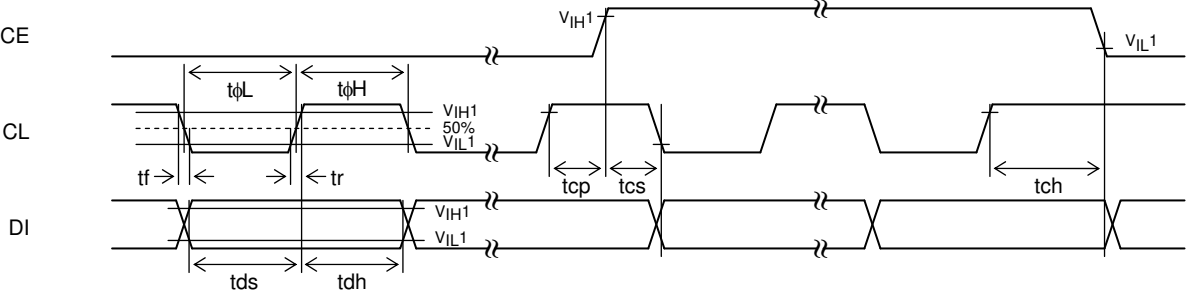

[Fig 2]

3. OSCI pin clock timing in external clock operating mode.

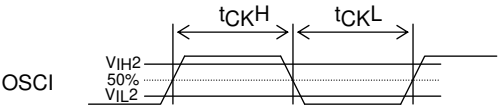

$$f_{CK} = \frac{1}{t_{CKH} + t_{CKL}} \text{ [kHz]}$$

$$D_{CK} = \frac{t_{CKH}}{t_{CKH} + t_{CKL}} \times 100\%$$

[Fig 3]

LC75805PE

Package Dimensions

unit : mm

PQFP100 14x20 / QIP100E

CASE 122BV

ISSUE A

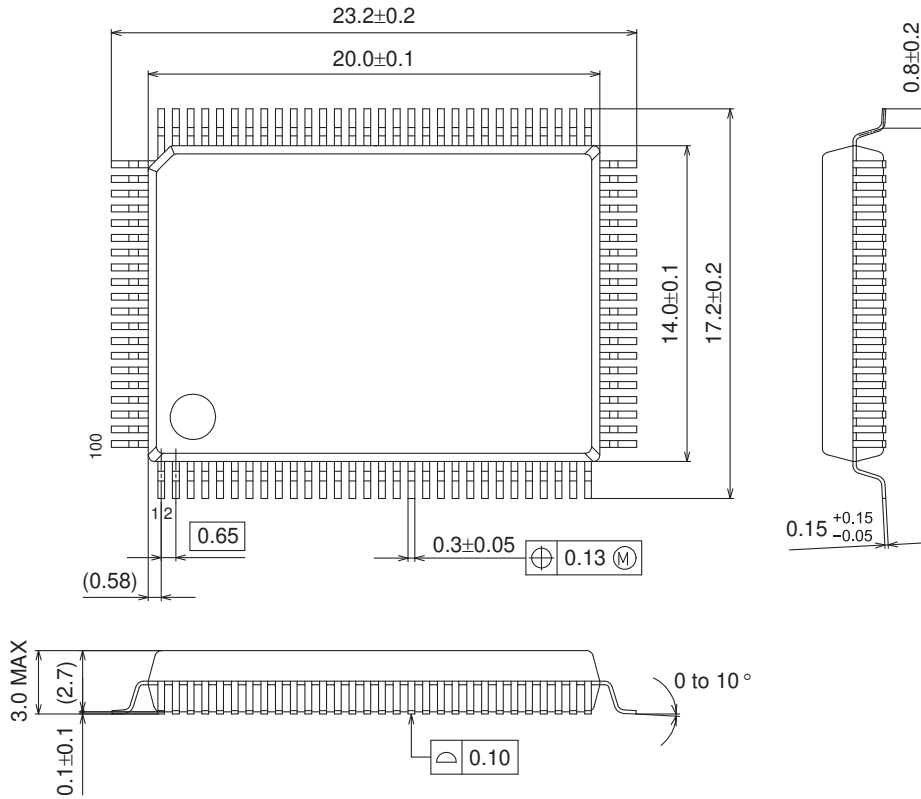

SOLDERING FOOTPRINT*

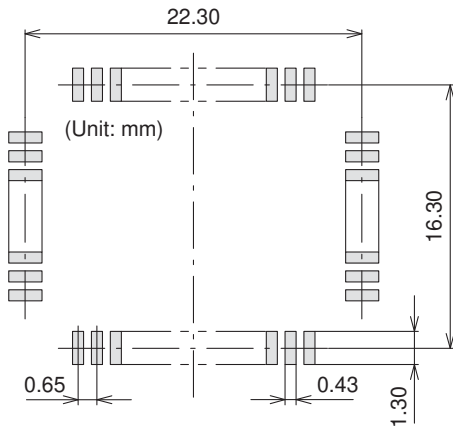

GENERIC MARKING DIAGRAM*

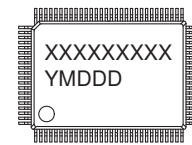

XXXXX = Specific Device Code
 Y = Year
 M = Month
 DDD = Additional Traceability Data

NOTE: The measurements are not to guarantee but for reference only.

*For additional information on our Pb-Free strategy and soldering details, please download the ON Semiconductor Soldering and Mounting Techniques Reference Manual, SOLDERRM/D.

*This information is generic. Please refer to device data sheet for actual part marking. Pb-Free indicator, "G" or microdot "▪", may or may not be present.

LC75805PE

Pin Assignment

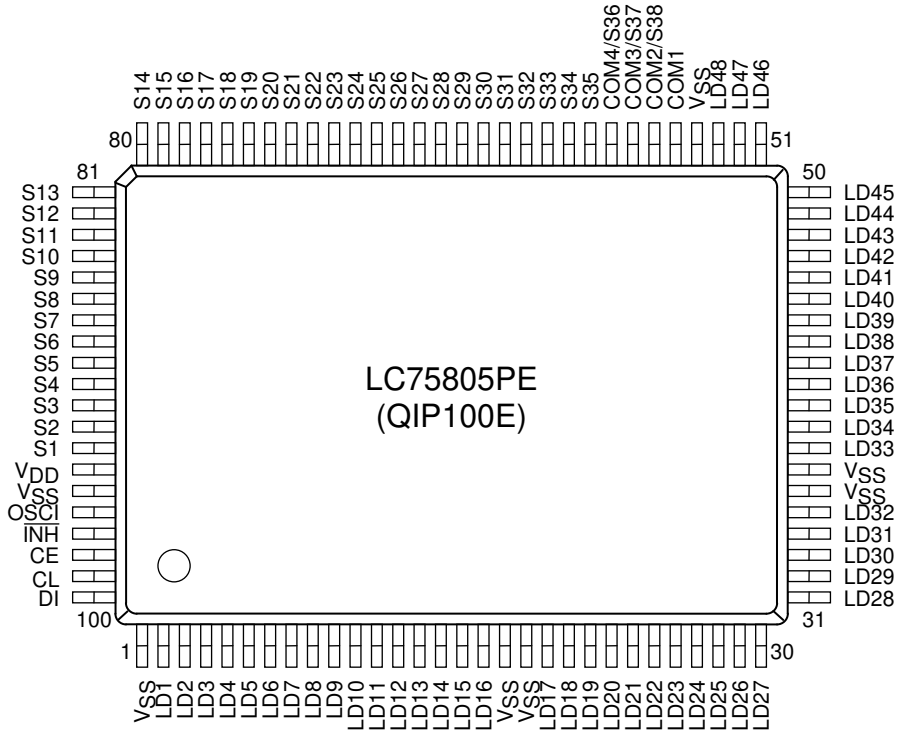

Top view

Block Diagram

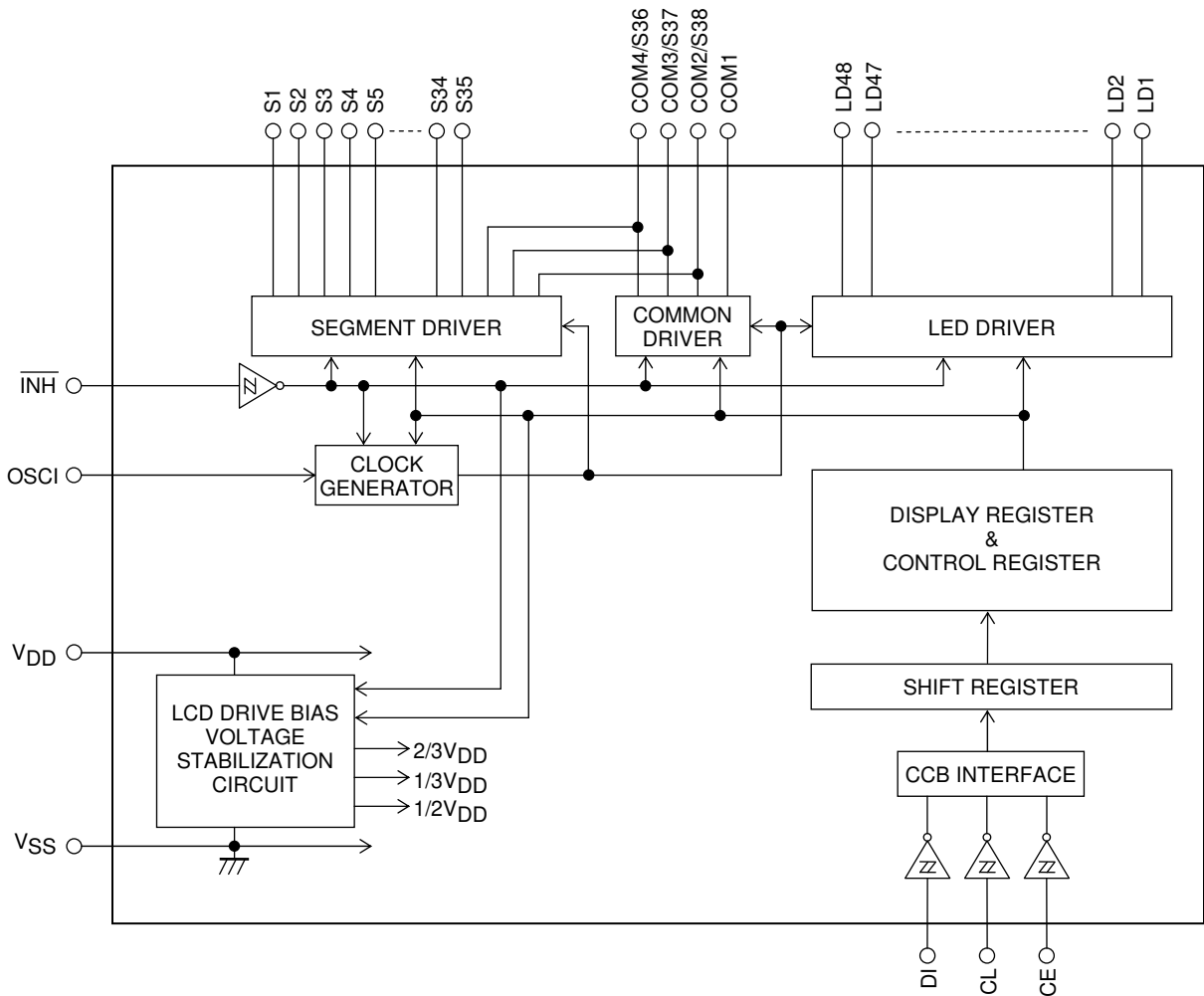

LC75805PE

Pin Functions

Symbol	Pin No.	Function	Active	I/O	Handling when unused
LD1 to LD16 LD17 to LD32 LD33 to LD48	2 to 17 20 to 35 38 to 53	These are LED driver output pins that display the display data for LED transferred by serial data input, and high- voltage open-drain output pins. (Pull-up voltage is 30[V] maximum.) In addition, brightness adjustment of LED is possible by PWM function, too.	-	O	OPEN
COM1 COM2/S38 COM3/S37 COM4/S36	55 56 57 58	These are common driver output pins, and Frame frequency is f_o [Hz]. COM2/S38, COM3/S37 and COM4/S36 are possible to be used as the segment output by control data.	-	O	OPEN
S35 to S1	59 to 93	These are segment output pins that display the display data for LCD transferred by serial data input.	-	O	OPEN
OSCI	96	This is input pin for the external clock. Input the clock whose frequency (f_{CK}) is between 100 and 600[kHz] at external clock operating mode. Furthermore, connect to GND at internal oscillator operating mode.	-	I	GND
CE CL DI	98 99 100	These are input pins for serial data transfer, and connect to the controller. CE: Chip enable CL: Synchronized clock DI: Transfer data	H  -	I I I	GND
$\overline{\text{INH}}$	97	Display off control input pin • $\overline{\text{INH}}$ = Low-level (V_{SS}) ...Display forced off LD1 to LD48 = Z (High-impedance) COM1 = L (V_{SS}) COM2/S38 to COM4/S36 = L (V_{SS}) S1 to S35 = L (V_{SS}) Internal oscillator operation is stopped. External clock input is forbidden. • $\overline{\text{INH}}$ = High-level (V_{DD})...Display on Internal oscillator operation is possible. (At Internal oscillator operating mode) External clock input is possible. (At External clock operating mode) However, serial data can be transferred during turn off.	L	I	GND
V_{DD}	94	This is power supply pin. Supply the voltage between 4.5V and 5.5V.	-	-	-
V_{SS}	1 18 19 36 37 54 95	These are power supply pins. Connect to GND.	-	-	-

LC75805PE

Serial Data Transfer Format

1/4 Duty Drive

(1) When CL is stopped at the low level

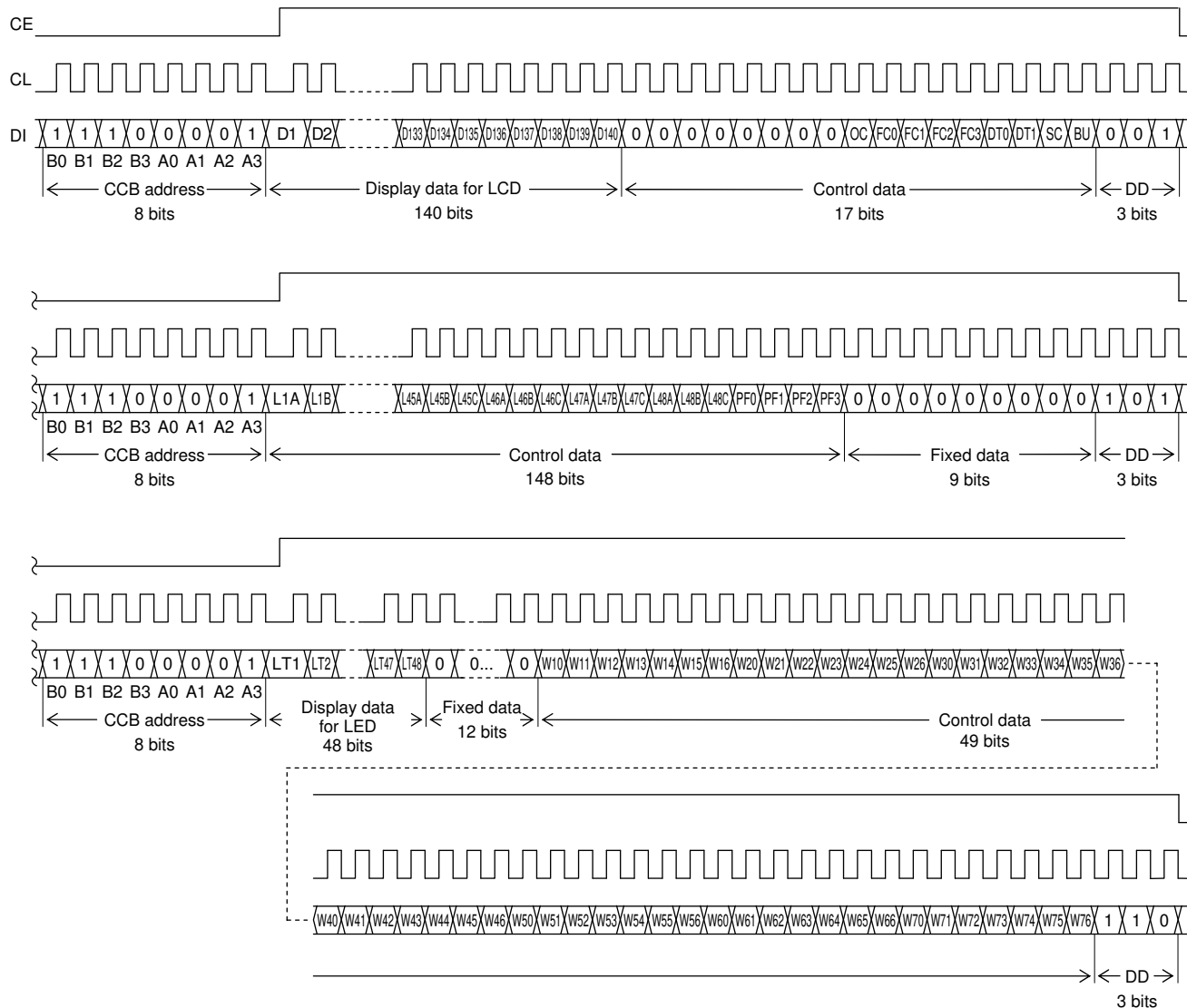

(Note 1) The input of serial data is taken in at the rising edge of CL, and latched at the falling edge of CE. In addition, this IC has the function that counts the number of CL clock to receive the correct serial data. That is to say, because it isn't latched at the falling edge of CE when the number of the count of CL in each serial data is wrong, receiving wrong serial data can be prevented.

(Note 2) DD ••• Direction Data

- CCB address “87H”
- D1 to D140 Display data for LCD
- OC Control data for switch of internal oscillator operating mode and external clock operating mode
- FC0 to FC3 Control data for setting of the frame frequency of common and segment output waveform
- DT0, DT1 Control data for setting of drive scheme (setting of 1/1 to 1/4 Duty Drive scheme) of LCD
- SC Control data for turning on/off segments
- BU Control data for switch of Normal mode and Power-saving mode
- L1A, L1B, L1C to L48A, Control data for Ch settings of PWM circuits that adjust brightness of LED
L48B, L48C
- PF0 to PF3 Control data for setting of the frame frequency of LED driver output waveform
- LT1 to LT48 Display data for LED
- W10 to W16, W20 to W26, ... PWM data of PWM circuits of LED driver output
W30 to W36, W40 to W46,
W50 to W56, W60 to W66
W70 to W76

LC75805PE

(2) When CL is stopped at the high level

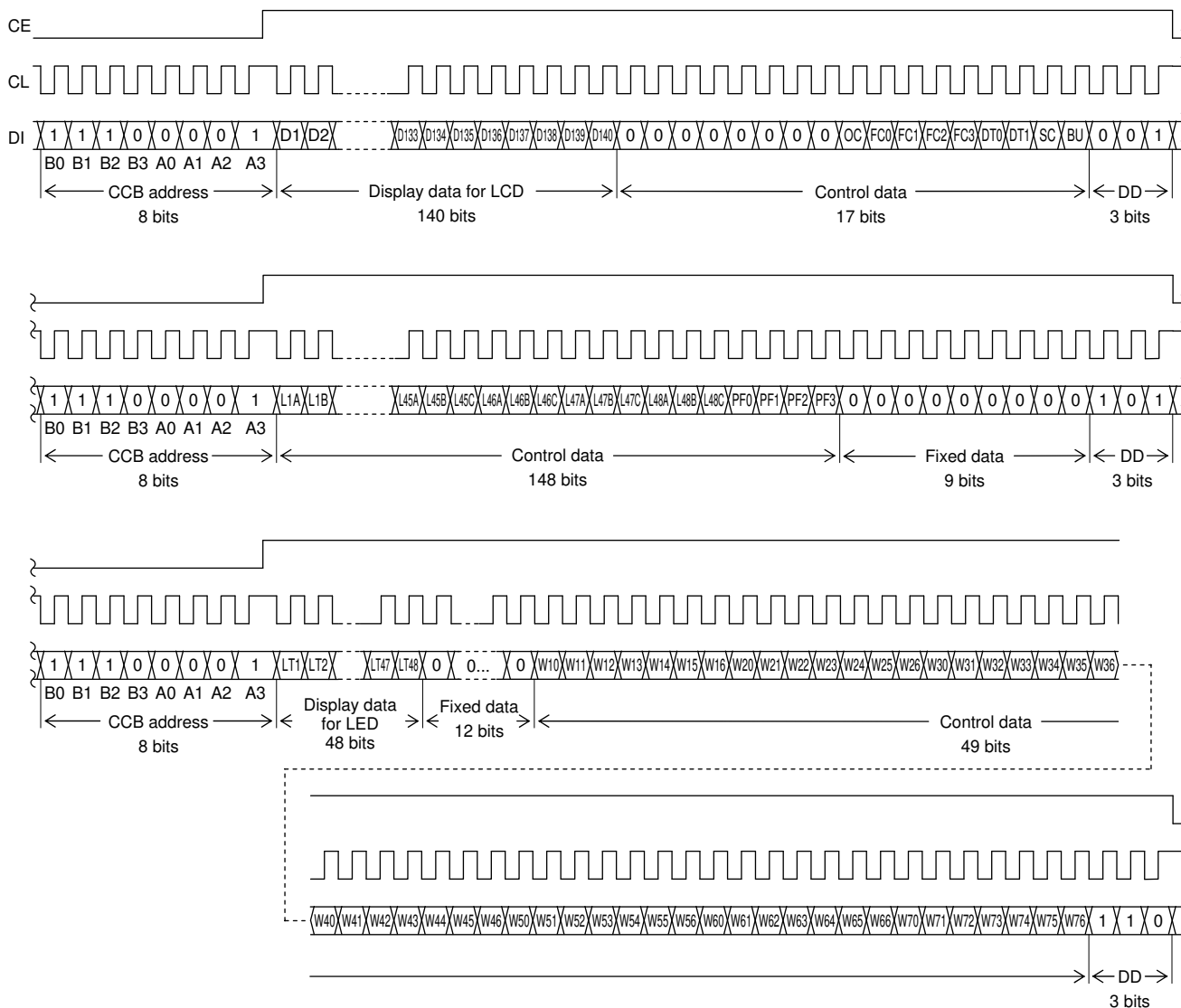

(Note 1) The input of serial data is taken in at the rising edge of CL, and latched at the falling edge of CE. In addition, this IC has the function that counts the number of CL clock to receive the correct serial data. That is to say, because it isn't latched at the falling edge of CE when the number of the count of CL in each serial data is wrong, receiving wrong serial data can be prevented.

(Note 2) DD ••• Direction Data

- CCB address “87H”
- D1 to D140 Display data for LCD
- OC Control data for switch of internal oscillator operating mode and external clock operating mode
- FC0 to FC3 Control data for setting of the frame frequency of common and segment output waveform
- DT0, DT1 Control data for setting of drive scheme (setting of 1/1 to 1/4 Duty Drive scheme) of LCD
- SC Control data for turning on/off segments
- BU Control data for switch of Normal mode and Power-saving mode
- L1A, L1B, L1C to L48A, Control data for Ch settings of PWM circuits that adjust brightness of LED L48B, L48C
- PF0 to PF3 Control data for setting of the frame frequency of LED driver output waveform
- LT1 to LT48 Display data for LED
- W10 to W16, W20 to W26, ... PWM data of PWM circuits of LED driver output W30 to W36, W40 to W46, W50 to W56, W60 to W66 W70 to W76

LC75805PE

1/3 Duty Drive

(1) When CL is stopped at the low level

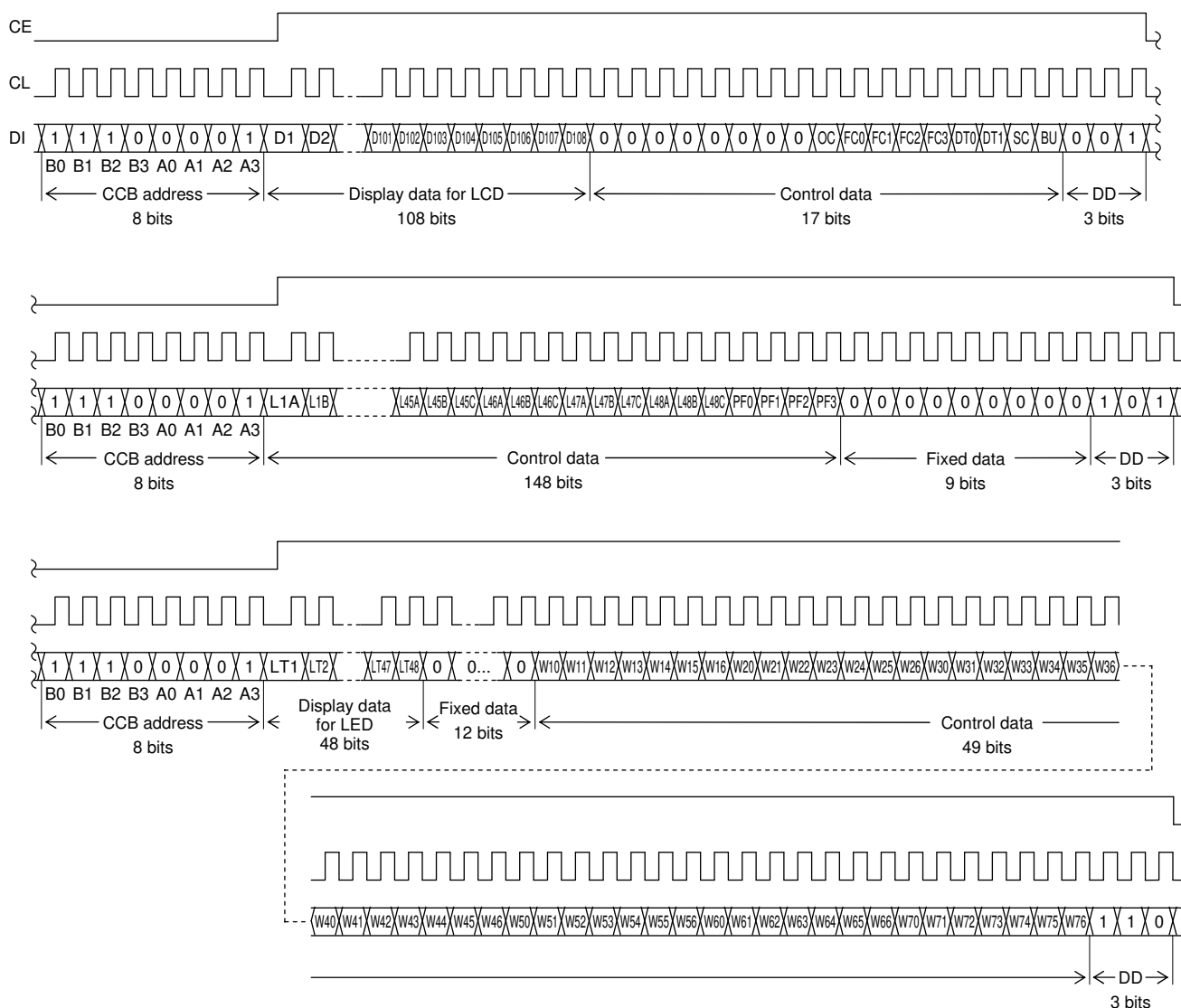

(Note 1) The input of serial data is taken in at the rising edge of CL, and latched at the falling edge of CE. In addition, this IC has the function that counts the number of CL clock to receive the correct serial data. That is to say, because it isn't latched at the falling edge of CE when the number of the count of CL in each serial data is wrong, receiving wrong serial data can be prevented.

(Note 2) DD ••• Direction Data

- CCB address “87H”
- D1 to D108 Display data for LCD
- OC Control data for switch of internal oscillator operating mode and external clock operating mode
- FC0 to FC3 Control data for setting of the frame frequency of common and segment output waveform
- DT0, DT1 Control data for setting of drive scheme (setting of 1/1 to 1/4 Duty Drive scheme) of LCD
- SC Control data for turning on/off segments
- BU Control data for switch of Normal mode and Power-saving mode
- L1A, L1B, L1C to L48A, Control data for Ch settings of PWM circuits that adjust brightness of LED
L48B, L48C
- PF0 to PF3 Control data for setting of the frame frequency of LED driver output waveform
- LT1 to LT48 Display data for LED
- W10 to W16, W20 to W26, ... PWM data of PWM circuits of LED driver output
W30 to W36, W40 to W46,
W50 to W56, W60 to W66
W70 to W76

LC75805PE

(2) When CL is stopped at the high level

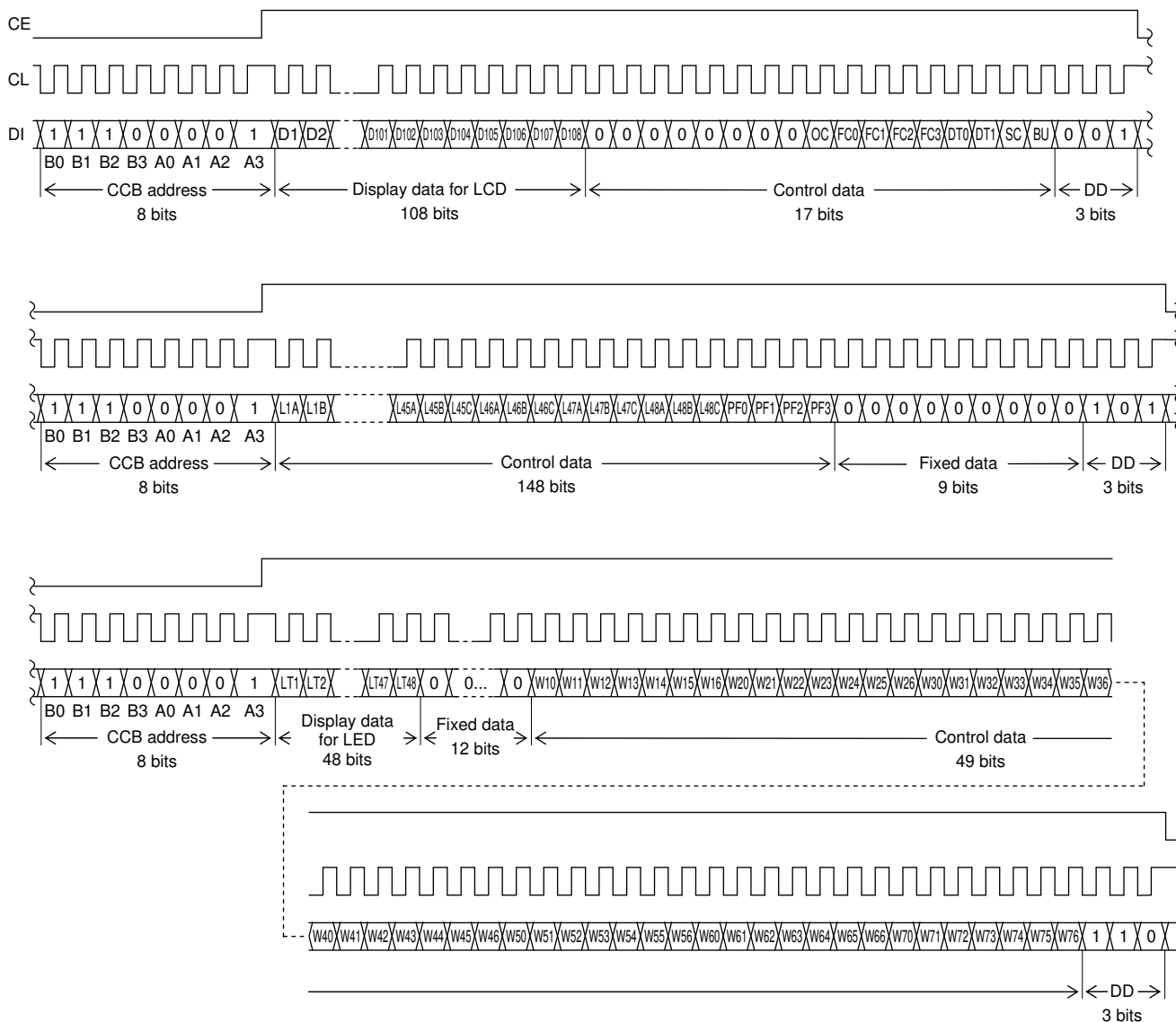

(Note 1) The input of serial data is taken in at the rising edge of CL, and latched at the falling edge of CE. In addition, this IC has the function that counts the number of CL clock to receive the correct serial data. That is to say, because it isn't latched at the falling edge of CE when the number of the count of CL in each serial data is wrong, receiving wrong serial data can be prevented.

(Note 2) DD ••• Direction Data

- CCB address “87H”
- D1 to D108 Display data for LCD
- OC Control data for switch of internal oscillator operating mode and external clock operating mode
- FC0 to FC3 Control data for setting of the frame frequency of common and segment output waveform
- DT0, DT1 Control data for setting of drive scheme (setting of 1/1 to 1/4 Duty Drive scheme) of LCD
- SC Control data for turning on/off segments
- BU Control data for switch of Normal mode and Power-saving mode
- L1A, L1B, L1C to L48A, Control data for Ch settings of PWM circuits that adjust brightness of LED L48B, L48C
- PF0 to PF3 Control data for setting of the frame frequency of LED driver output waveform
- LT1 to LT48 Display data for LED
- W10 to W16, W20 to W26, ... PWM data of PWM circuits of LED driver output
W30 to W36, W40 to W46,
W50 to W56, W60 to W66
W70 to W76

LC75805PE

1/2 Duty Drive

(1) When CL is stopped at the low level

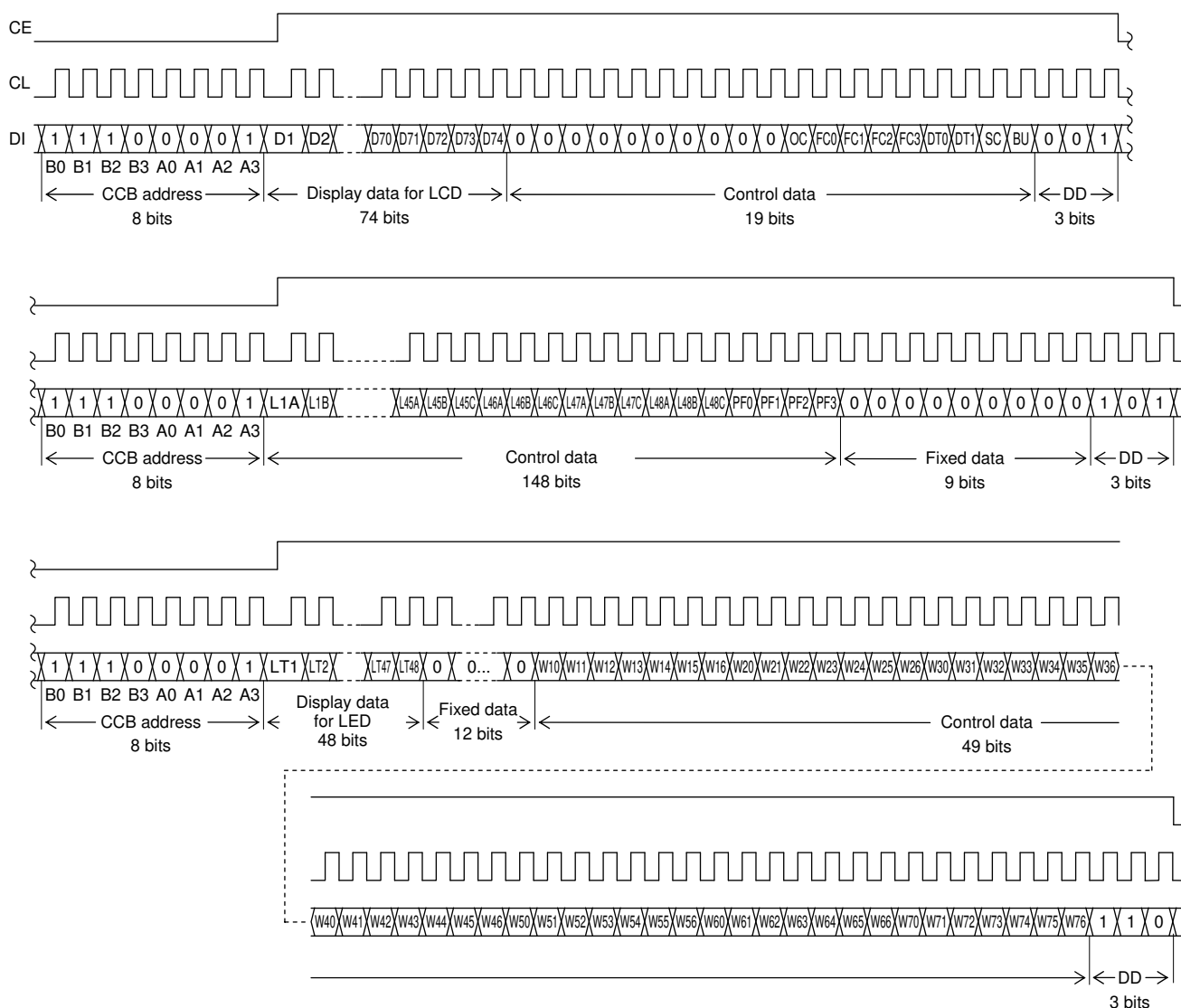

(Note 1) The input of serial data is taken in at the rising edge of CL, and latched at the falling edge of CE. In addition, this IC has the function that counts the number of CL clock to receive the correct serial data. That is to say, because it isn't latched at the falling edge of CE when the number of the count of CL in each serial data is wrong, receiving wrong serial data can be prevented.

(Note 2) DD ••• Direction Data

- CCB address “87H”
- D1 to D74 Display data for LCD
- OC Control data for switch of internal oscillator operating mode and external clock operating mode
- FC0 to FC3 Control data for setting of the frame frequency of common and segment output waveform
- DT0, DT1 Control data for setting of drive scheme (setting of 1/1 to 1/4 Duty Drive scheme) of LCD
- SC Control data for turning on/off segments
- BU Control data for switch of Normal mode and Power-saving mode
- L1A, L1B, L1C to L48A, Control data for Ch settings of PWM circuits that adjust brightness of LED
L48B, L48C
- PF0 to PF3 Control data for setting of the frame frequency of LED driver output waveform
- LT1 to LT48 Display data for LED
- W10 to W16, W20 to W26, ... PWM data of PWM circuits of LED driver output
W30 to W36, W40 to W46,
W50 to W56, W60 to W66
W70 to W76

LC75805PE

(2) When CL is stopped at the high level

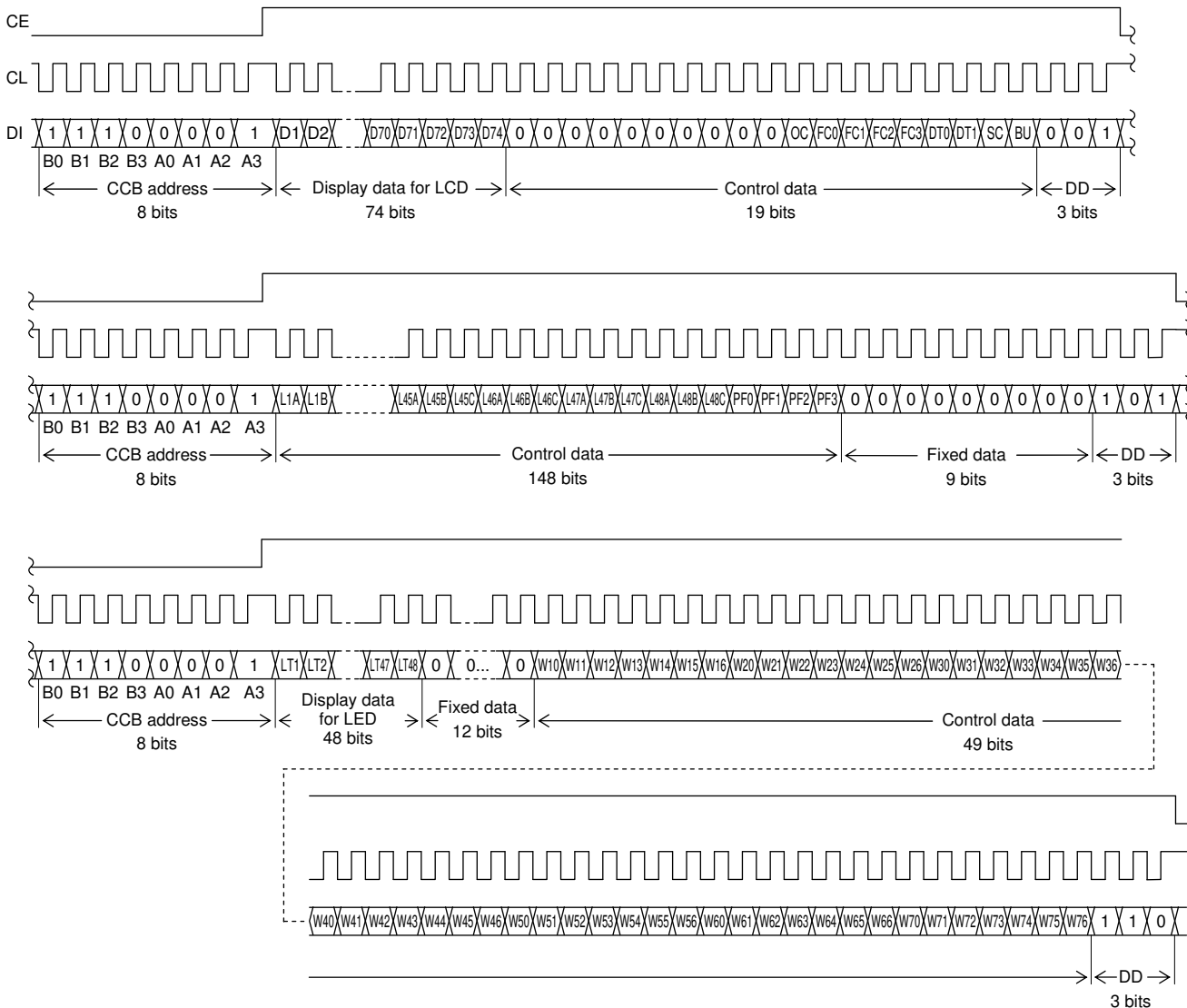

(Note 1) The input of serial data is taken in at the rising edge of CL, and latched at the falling edge of CE. In addition, this IC has the function that counts the number of CL clock to receive the correct serial data. That is to say, because it isn't latched at the falling edge of CE when the number of the count of CL in each serial data is wrong, receiving wrong serial data can be prevented.

(Note 2) DD ••• Direction Data

- CCB address “87H”
- D1 to D74 Display data for LCD
- OC Control data for switch of internal oscillator operating mode and external clock operating mode
- FC0 to FC3 Control data for setting of the frame frequency of common and segment output waveform
- DT0, DT1 Control data for setting of drive scheme (setting of 1/1 to 1/4 Duty Drive scheme) of LCD
- SC Control data for turning on/off segments
- BU Control data for switch of Normal mode and Power-saving mode
- L1A, L1B, L1C to L48A,..... Control data for Ch settings of PWM circuits that adjust brightness of LED L48B, L48C
- PF0 to PF3 Control data for setting of the frame frequency of LED driver output waveform
- LT1 to LT48 Display data for LED
- W10 to W16, W20 to W26,... PWM data of PWM circuits of LED driver output W30 to W36, W40 to W46, W50 to W56, W60 to W66 W70 to W76

LC75805PE

Static Drive (1/1 Duty Drive)

(1) When CL is stopped at the low level

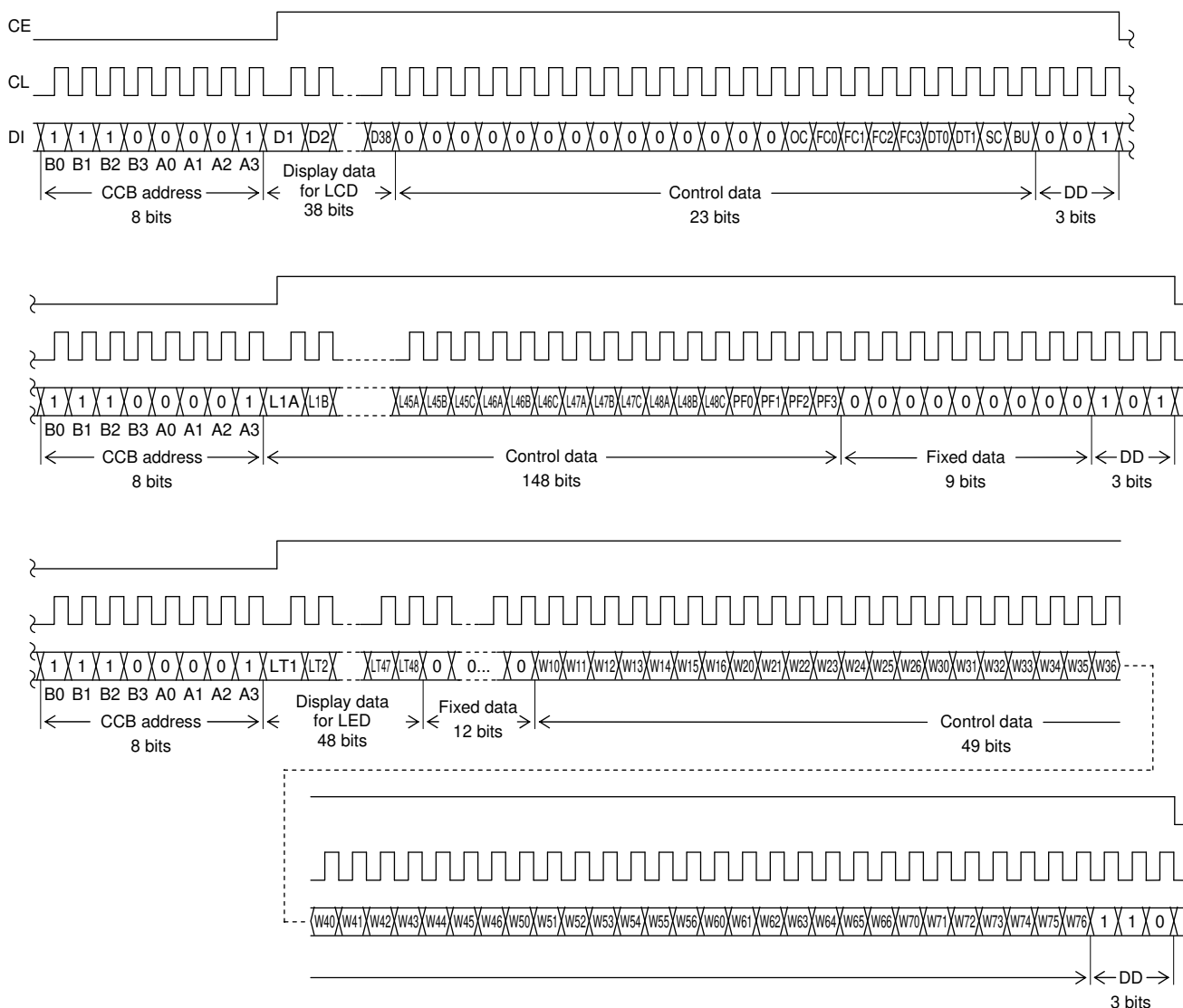

(Note 1) The input of serial data is taken in at the rising edge of CL, and latched at the falling edge of CE. In addition, this IC has the function that counts the number of CL clock to receive the correct serial data. That is to say, because it isn't latched at the falling edge of CE when the number of the count of CL in each serial data is wrong, receiving wrong serial data can be prevented.

(Note 2) DD ••• Direction Data

- CCB address “87H”
- D1 to D38 Display data for LCD
- OC Control data for switch of internal oscillator operating mode and external clock operating mode
- FC0 to FC3 Control data for setting of the frame frequency of common and segment output waveform
- DT0, DT1 Control data for setting of drive scheme (setting of 1/1 to 1/4 Duty Drive scheme) of LCD
- SC Control data for turning on/off segments
- BU Control data for switch of Normal mode and Power-saving mode
- L1A, L1B, L1C to L48A, Control data for Ch settings of PWM circuits that adjust brightness of LED
L48B, L48C
- PF0 to PF3 Control data for setting of the frame frequency of LED driver output waveform
- LT1 to LT48 Display data for LED
- W10 to W16, W20 to W26, ... PWM data of PWM circuits of LED driver output
W30 to W36, W40 to W46,
W50 to W56, W60 to W66
W70 to W76

LC75805PE

(2) When CL is stopped at the high level

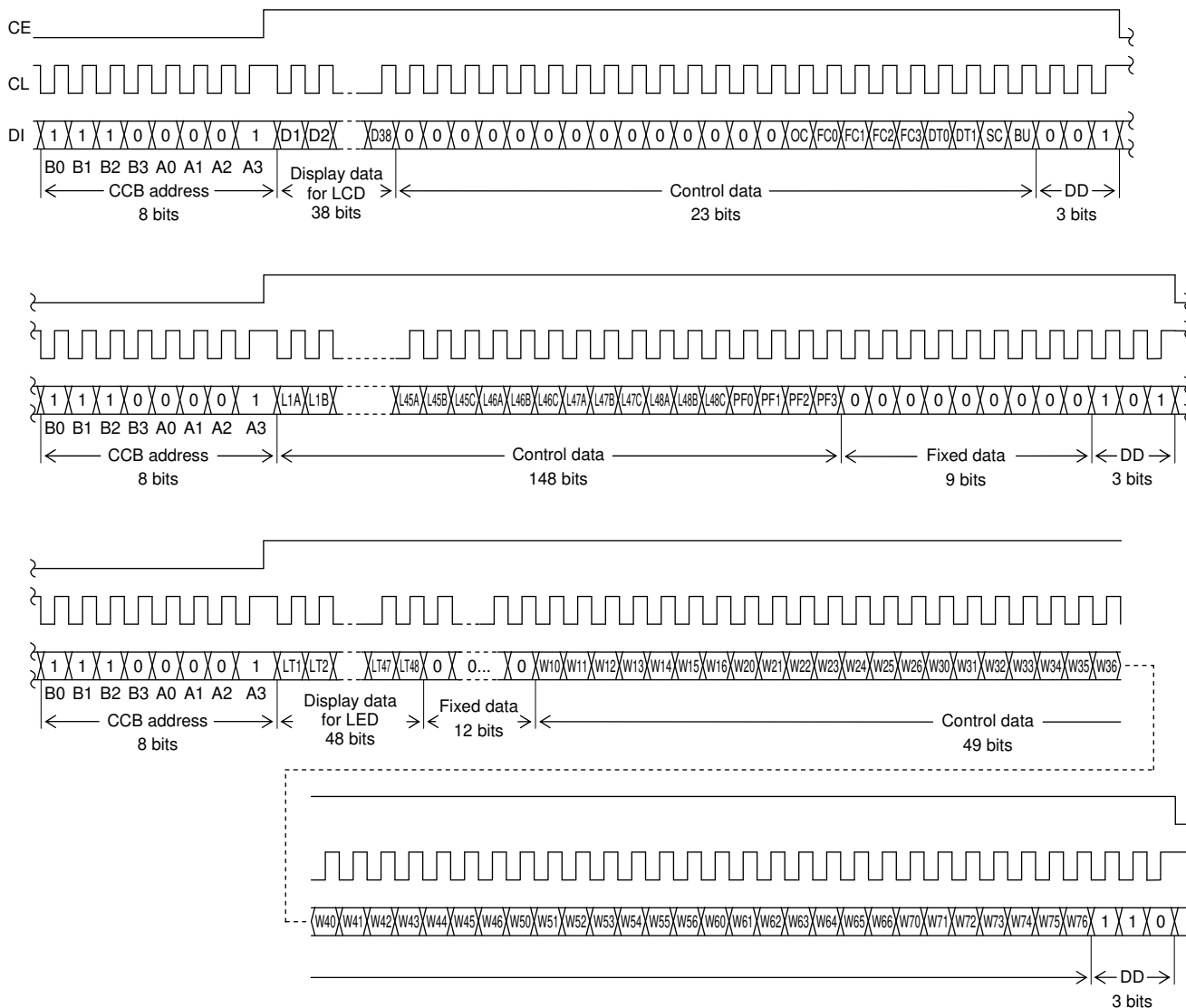

(Note 1) The input of serial data is taken in at the rising edge of CL, and latched at the falling edge of CE. In addition, this IC has the function that counts the number of CL clock to receive the correct serial data. That is to say, because it isn't latched at the falling edge of CE when the number of the count of CL in each serial data is wrong, receiving wrong serial data can be prevented.

(Note 2) DD ••• Direction Data

- CCB address “87H”
- D1 to D38 Display data for LCD
- OC Control data for switch of internal oscillator operating mode and external clock operating mode
- FC0 to FC3 Control data for setting of the frame frequency of common and segment output waveform
- DT0, DT1 Control data for setting of drive scheme (setting of 1/1 to 1/4 Duty Drive scheme) of LCD
- SC Control data for turning on/off segments
- BU Control data for switch of Normal mode and Power-saving mode
- L1A, L1B, L1C to L48A, Control data for Ch settings of PWM circuits that adjust brightness of LED
L48B, L48C
- PF0 to PF3 Control data for setting of the frame frequency of LED driver output waveform
- LT1 to LT48 Display data for LED
- W10 to W16, W20 to W26, ... PWM data of PWM circuits of LED driver output
W30 to W36, W40 to W46,
W50 to W56, W60 to W66
W70 to W76

Control data Functions

(1) OC ... Control data for switch of internal oscillator operating mode and external clock operating mode

This control data bit selects either the internal oscillator operating mode or external clock operating mode.

OC	Fundamental clock operating mode	Input pin (OSCI) state
0	Internal oscillator operating mode	Connect to GND
1	External clock operating mode	Input the clock ($f_{CK} = 100$ to 600 [kHz]) from the outside

(2) FC0 to FC3 ... Control data for setting of the frame frequency of common and segment output waveform

These control data bits set the frame frequency of common and segment output waveform.

FC0	FC1	FC2	FC3	Frame frequency of common and segment output waveform f_o [Hz]	
				Internal oscillator operating mode (Control data OC = "0", $f_{osc} = 300$ [kHz] typ)	External clock operating mode (Control data OC = "1", $f_{CK} = 300$ [kHz] typ)
0	0	0	0	$f_{osc}/4992$	$f_{CK}/4992$
1	0	0	0	$f_{osc}/4608$	$f_{CK}/4608$
0	1	0	0	$f_{osc}/4224$	$f_{CK}/4224$
1	1	0	0	$f_{osc}/3840$	$f_{CK}/3840$
0	0	1	0	$f_{osc}/3456$	$f_{CK}/3456$
1	0	1	0	$f_{osc}/3072$	$f_{CK}/3072$
0	1	1	0	$f_{osc}/2688$	$f_{CK}/2688$
1	1	1	0	$f_{osc}/2496$	$f_{CK}/2496$
0	0	0	1	$f_{osc}/2448$	$f_{CK}/2448$
1	0	0	1	$f_{osc}/2304$	$f_{CK}/2304$
0	1	0	1	$f_{osc}/2112$	$f_{CK}/2112$
1	1	0	1	$f_{osc}/1920$	$f_{CK}/1920$
0	0	1	1	$f_{osc}/1728$	$f_{CK}/1728$
1	0	1	1	$f_{osc}/1536$	$f_{CK}/1536$
0	1	1	1	$f_{osc}/1344$	$f_{CK}/1344$
1	1	1	1	$f_{osc}/1152$	$f_{CK}/1152$

(3) DT0, DT1 ... Control data for setting of drive scheme (setting of 1/1 to 1/4 Duty Drive scheme) of LCD

These control bits select 1/4-Duty 1/3-Bias Drive, 1/3-Duty 1/3-Bias Drive, 1/2-Duty 1/2-Bias Drive, or Static Drive (1/1-Duty Drive) of LCD.

DT0	DT1	Drive scheme for LCD	Each pin state		
			COM2/S38	COM3/S37	COM4/S36
0	0	1/4-Duty 1/3-Bias Drive	COM2	COM3	COM4
1	0	1/3-Duty 1/3-Bias Drive	COM2	COM3	S36
0	1	1/2-Duty 1/2-Bias Drive	COM2	S37	S36
1	1	Static Drive (1/1-Duty Drive)	S38	S37	S36

Note) COM2 to COM4: Common output / S38 to S36: Segment output

(4) SC ... Control data for turning on/off segments

This control data bit controls the on/off state of the segments.

SC	Display state
0	On
1	Off

Note that when the segments are turned off by setting SC to 1, the segments are turning off by outputting segment off waveforms from the segment output pins.

LC75805PE

(5) BU ... Control data for switch of Normal mode and Power-saving mode

This control data bit selects either Normal mode or Power-saving mode.

BU	Mode
0	Normal mode
1	Power-saving mode (The oscillation of internal oscillator circuit is stopped when internal oscillator operating mode (OC = [0]), and the receiving of external clock isn't admitted when external clock operating mode (OC = [1]). In addition, common and segment output pins are V_{SS} level, and LED driver output pins are High impedance.)

(6) L1A, L1B, L1C to L48A, L48B, L48C ... Control data for Ch settings of PWM circuits that adjust brightness of LED

These control data bits set the Ch of PWM circuit for LED driver output pins, LD1 to LD48.

LnA	LnB	LnC	Ch of PWM circuit for LED driver output LDn
0	0	0	PWM circuit is not selected. (The setting of turning on/off of the duty 100% by Display data LTn for LED is possible.)
1	0	0	PWM circuit (Ch1) is selected.
0	1	0	PWM circuit (Ch2) is selected.
1	1	0	PWM circuit (Ch3) is selected.
0	0	1	PWM circuit (Ch4) is selected.
1	0	1	PWM circuit (Ch5) is selected.
0	1	1	PWM circuit (Ch6) is selected.
1	1	1	PWM circuit (Ch7) is selected.

Note) LnA, LnB, LnC (n = 1 to 48) data are control data that set the Ch of PWM circuit for LED driver output pins LDn (n = 1 to 48).

For example, if (L1A, L1B, L1C) = (1, 0, 0), (L11A, L11B, L11C) = (1, 1, 0) and (L21A, L21B, L21C) = (0, 1, 1) is set, LED driver output pin LD1 select PWM circuit (Ch1) and LED driver output pin LD11 select PWM circuit (Ch3) and LED driver output pin LD21 select PWM circuit (Ch6).

(7) PF0 to PF3 ... Control data for setting of the frame frequency of LED driver output waveform

These control data bits set the frame frequency of LED driver output waveform of LED output pin setting PWM circuit (Ch1 to Ch7).

PF0	PF1	PF2	PF3	Frame frequency of LED driver output waveform f_p [Hz]	
				Internal oscillator operating mode (Control data OC = "0", $f_{osc} = 300$ [kHz] typ)	External clock operating mode (Control data OC = "1", $f_{CK} = 300$ [kHz] typ)
0	0	0	0	$f_{osc}/1664$	$f_{CK}/1664$
1	0	0	0	$f_{osc}/1536$	$f_{CK}/1536$
0	1	0	0	$f_{osc}/1408$	$f_{CK}/1408$
1	1	0	0	$f_{osc}/1280$	$f_{CK}/1280$
0	0	1	0	$f_{osc}/1152$	$f_{CK}/1152$
1	0	1	0	$f_{osc}/1024$	$f_{CK}/1024$
0	1	1	0	$f_{osc}/896$	$f_{CK}/896$
1	1	1	0	$f_{osc}/768$	$f_{CK}/768$
0	0	0	1	$f_{osc}/640$	$f_{CK}/640$
1	0	0	1	$f_{osc}/512$	$f_{CK}/512$

Note) If (PF0, PF1, PF2, PF3) = (X, 1, 0, 1), (X, X, 1, 1) are set, the frame frequency ($f_{osc}/1408$, $f_{CK}/1408$) of setting (PF0, PF1, PF2, PF3) = (0, 1, 0, 0) is selected.

LC75805PE

(8) W10 to W16, W20 to W26, W30 to W36, W40 to W46, W50 to W56, W60 to W66, W70 to W76

... PWM data of PWM circuit for LED driver output

These control data bits set LED lighting time per 1 frame of LED driver output waveform of LED driver output pin setting PWM circuit (Ch1 to Ch7).

Wn0	Wn1	Wn2	Wn3	Wn4	Wn5	Wn6	LED lighting time per 1 frame
0	0	0	0	0	0	0	(1/128) × Tp
1	0	0	0	0	0	0	(2/128) × Tp
0	1	0	0	0	0	0	(3/128) × Tp
1	1	0	0	0	0	0	(4/128) × Tp
0	0	1	0	0	0	0	(5/128) × Tp
1	0	1	0	0	0	0	(6/128) × Tp
0	1	1	0	0	0	0	(7/128) × Tp
1	1	1	0	0	0	0	(8/128) × Tp
0	0	0	1	0	0	0	(9/128) × Tp
1	0	0	1	0	0	0	(10/128) × Tp
0	1	0	1	0	0	0	(11/128) × Tp
1	1	0	1	0	0	0	(12/128) × Tp
0	0	1	1	0	0	0	(13/128) × Tp
1	0	1	1	0	0	0	(14/128) × Tp
0	1	1	1	0	0	0	(15/128) × Tp
1	1	1	1	0	0	0	(16/128) × Tp
0	0	0	0	1	0	0	(17/128) × Tp
1	0	0	0	1	0	0	(18/128) × Tp
0	1	0	0	1	0	0	(19/128) × Tp
1	1	0	0	1	0	0	(20/128) × Tp
0	0	1	0	1	0	0	(21/128) × Tp
1	0	1	0	1	0	0	(22/128) × Tp
0	1	1	0	1	0	0	(23/128) × Tp
1	1	1	0	1	0	0	(24/128) × Tp
0	0	0	1	1	0	0	(25/128) × Tp
1	0	0	1	1	0	0	(26/128) × Tp
0	1	0	1	1	0	0	(27/128) × Tp
1	1	0	1	1	0	0	(28/128) × Tp
0	0	1	1	1	0	0	(29/128) × Tp
1	0	1	1	1	0	0	(30/128) × Tp
0	1	1	1	1	0	0	(31/128) × Tp
1	1	1	1	1	0	0	(32/128) × Tp
0	0	0	0	0	1	0	(33/128) × Tp
1	0	0	0	0	1	0	(34/128) × Tp
0	1	0	0	0	1	0	(35/128) × Tp
1	1	0	0	0	1	0	(36/128) × Tp
0	0	1	0	0	1	0	(37/128) × Tp
1	0	1	0	0	1	0	(38/128) × Tp
0	1	1	0	0	1	0	(39/128) × Tp
1	1	1	0	0	1	0	(40/128) × Tp
0	0	0	1	0	1	0	(41/128) × Tp
1	0	0	1	0	1	0	(42/128) × Tp
0	1	0	1	0	1	0	(43/128) × Tp
1	1	0	1	0	1	0	(44/128) × Tp
0	0	1	1	0	1	0	(45/128) × Tp
1	0	1	1	0	1	0	(46/128) × Tp
0	1	1	1	0	1	0	(47/128) × Tp
1	1	1	1	0	1	0	(48/128) × Tp
0	0	0	0	1	1	0	(49/128) × Tp
1	0	0	0	1	1	0	(50/128) × Tp
0	1	0	0	1	1	0	(51/128) × Tp
1	1	0	0	1	1	0	(52/128) × Tp
0	0	1	0	1	1	0	(53/128) × Tp
1	0	1	0	1	1	0	(54/128) × Tp
0	1	1	0	1	1	0	(55/128) × Tp
1	1	1	0	1	1	0	(56/128) × Tp
0	0	0	1	1	1	0	(57/128) × Tp
1	0	0	1	1	1	0	(58/128) × Tp
0	1	0	1	1	1	0	(59/128) × Tp
1	1	0	1	1	1	0	(60/128) × Tp
0	0	1	1	1	1	0	(61/128) × Tp
1	0	1	1	1	1	0	(62/128) × Tp
0	1	1	1	1	1	0	(63/128) × Tp
1	1	1	1	1	1	0	(64/128) × Tp

Wn0	Wn1	Wn2	Wn3	Wn4	Wn5	Wn6	LED lighting time per 1 frame
0	0	0	0	0	0	1	(65/128) × Tp
1	0	0	0	0	0	1	(66/128) × Tp
0	1	0	0	0	0	1	(67/128) × Tp
1	1	0	0	0	0	1	(68/128) × Tp
0	0	1	0	0	0	1	(69/128) × Tp
1	0	1	0	0	0	1	(70/128) × Tp
0	1	1	0	0	0	1	(71/128) × Tp
1	1	1	0	0	0	1	(72/128) × Tp
0	0	0	1	0	0	1	(73/128) × Tp
1	0	0	1	0	0	1	(74/128) × Tp
0	1	0	1	0	0	1	(75/128) × Tp
1	1	0	1	0	0	1	(76/128) × Tp
0	0	1	1	0	0	1	(77/128) × Tp
1	0	1	1	0	0	1	(78/128) × Tp
0	1	1	1	0	0	1	(79/128) × Tp
1	1	1	1	0	0	1	(80/128) × Tp
0	0	0	0	1	0	1	(81/128) × Tp
1	0	0	0	1	0	1	(82/128) × Tp
0	1	0	0	1	0	1	(83/128) × Tp
1	1	0	0	1	0	1	(84/128) × Tp
0	0	1	0	1	0	1	(85/128) × Tp
1	0	1	0	1	0	1	(86/128) × Tp
0	1	1	0	1	0	1	(87/128) × Tp
1	1	1	0	1	0	1	(88/128) × Tp
0	0	0	1	1	0	1	(89/128) × Tp
1	0	0	1	1	0	1	(90/128) × Tp
0	1	0	1	1	0	1	(91/128) × Tp
1	1	0	1	1	0	1	(92/128) × Tp
0	0	1	1	1	0	1	(93/128) × Tp
1	0	1	1	1	0	1	(94/128) × Tp
0	1	1	1	1	0	1	(95/128) × Tp
1	1	1	1	1	0	1	(96/128) × Tp
0	0	0	0	0	1	1	(97/128) × Tp
1	0	0	0	0	1	1	(98/128) × Tp
0	1	0	0	0	1	1	(99/128) × Tp
1	1	0	0	0	1	1	(100/128) × Tp
0	0	1	0	0	1	1	(101/128) × Tp
1	0	1	0	0	1	1	(102/128) × Tp
0	1	1	0	0	1	1	(103/128) × Tp
1	1	1	0	0	1	1	(104/128) × Tp
0	0	0	1	0	1	1	(105/128) × Tp
1	0	0	1	0	1	1	(106/128) × Tp
0	1	0	1	0	1	1	(107/128) × Tp
1	1	0	1	0	1	1	(108/128) × Tp
0	0	1	1	0	1	1	(109/128) × Tp
1	0	1	1	0	1	1	(110/128) × Tp
0	1	1	1	0	1	1	(111/128) × Tp
1	1	1	1	0	1	1	(112/128) × Tp
0	0	0	0	1	1	1	(113/128) × Tp
1	0	0	0	1	1	1	(114/128) × Tp
0	1	0	0	1	1	1	(115/128) × Tp
1	1	0	0	1	1	1	(116/128) × Tp
0	0	1	0	1	1	1	(117/128) × Tp
1	0	1	0	1	1	1	(118/128) × Tp
0	1	1	0	1	1	1	(119/128) × Tp
1	1	1	0	1	1	1	(120/128) × Tp
0	0	0	1	1	1	1	(121/128) × Tp
1	0	0	1	1	1	1	(122/128) × Tp
0	1	0	1	1	1	1	(123/128) × Tp
1	1	0	1	1	1	1	(124/128) × Tp
0	0	1	1	1	1	1	(125/128) × Tp
1	0	1	1	1	1	1	(126/128) × Tp
0	1	1	1	1	1	1	(127/128) × Tp
1	1	1	1	1	1	1	(128/128) × Tp

Note) W10 to W16 : PWM data of PWM circuit (Ch1) / W20 to W26 : PWM data of PWM circuit (Ch2)
 W30 to W36 : PWM data of PWM circuit (Ch3) / W40 to W46 : PWM data of PWM circuit (Ch4)
 W50 to W56 : PWM data of PWM circuit (Ch5) / W60 to W66 : PWM data of PWM circuit (Ch6)
 W70 to W76 : PWM data of PWM circuit (Ch7)

$$T_p = \frac{1}{f_p}$$

LC75805PE

Descriptions of Display data for LCD

(1) Correspondence of output pins to display data for LCD at 1/4 Duty Drive

Output Pin	COM1	COM2	COM3	COM4
S1	D1	D2	D3	D4
S2	D5	D6	D7	D8
S3	D9	D10	D11	D12
S4	D13	D14	D15	D16
S5	D17	D18	D19	D20
S6	D21	D22	D23	D24
S7	D25	D26	D27	D28
S8	D29	D30	D31	D32
S9	D33	D34	D35	D36
S10	D37	D38	D39	D40
S11	D41	D42	D43	D44
S12	D45	D46	D47	D48
S13	D49	D50	D51	D52
S14	D53	D54	D55	D56
S15	D57	D58	D59	D60
S16	D61	D62	D63	D64
S17	D65	D66	D67	D68
S18	D69	D70	D71	D72

Output Pin	COM1	COM2	COM3	COM4
S19	D73	D74	D75	D76
S20	D77	D78	D79	D80
S21	D81	D82	D83	D84
S22	D85	D86	D87	D88
S23	D89	D90	D91	D92
S24	D93	D94	D95	D96
S25	D97	D98	D99	D100
S26	D101	D102	D103	D104
S27	D105	D106	D107	D108
S28	D109	D110	D111	D112
S29	D113	D114	D115	D116
S30	D117	D118	D119	D120
S31	D121	D122	D123	D124
S32	D125	D126	D127	D128
S33	D129	D130	D131	D132
S34	D133	D134	D135	D136
S35	D137	D138	D139	D140

For example, the table below lists the output states for the S21 output pin.

Display data				Output pin (S21) state
D81	D82	D83	D84	
0	0	0	0	The LCD segments corresponding to COM1, COM2, COM3 and COM4 are off.
0	0	0	1	The LCD segment corresponding to COM4 is on.
0	0	1	0	The LCD segment corresponding to COM3 is on.
0	0	1	1	The LCD segments corresponding to COM3 and COM4 are on.
0	1	0	0	The LCD segment corresponding to COM2 is on.
0	1	0	1	The LCD segments corresponding to COM2 and COM4 are on.
0	1	1	0	The LCD segments corresponding to COM2 and COM3 are on.
0	1	1	1	The LCD segments corresponding to COM2, COM3 and COM4 are on.
1	0	0	0	The LCD segment corresponding to COM1 is on.
1	0	0	1	The LCD segments corresponding to COM1 and COM4 are on.
1	0	1	0	The LCD segments corresponding to COM1 and COM3 are on.
1	0	1	1	The LCD segments corresponding to COM1, COM3 and COM4 are on.
1	1	0	0	The LCD segments corresponding to COM1 and COM2 are on.
1	1	0	1	The LCD segments corresponding to COM1, COM2 and COM4 are on.
1	1	1	0	The LCD segments corresponding to COM1, COM2 and COM3 are on.
1	1	1	1	The LCD segments corresponding to COM1, COM2, COM3 and COM4 are on.

LC75805PE

(2) Correspondence of output pins to display data for LCD at 1/3 Duty Drive

Output Pin	COM1	COM2	COM3
S1	D1	D2	D3
S2	D4	D5	D6
S3	D7	D8	D9
S4	D10	D11	D12
S5	D13	D14	D15
S6	D16	D17	D18
S7	D19	D20	D21
S8	D22	D23	D24
S9	D25	D26	D27
S10	D28	D29	D30
S11	D31	D32	D33
S12	D34	D35	D36
S13	D37	D38	D39
S14	D40	D41	D42
S15	D43	D44	D45
S16	D46	D47	D48
S17	D49	D50	D51
S18	D52	D53	D54
S19	D55	D56	D57

Output Pin	COM1	COM2	COM3
S20	D58	D59	D60
S21	D61	D62	D63
S22	D64	D65	D66
S23	D67	D68	D69
S24	D70	D71	D72
S25	D73	D74	D75
S26	D76	D77	D78
S27	D79	D80	D81
S28	D82	D83	D84
S29	D85	D86	D87
S30	D88	D89	D90
S31	D91	D92	D93
S32	D94	D95	D96
S33	D97	D98	D99
S34	D100	D101	D102
S35	D103	D104	D105
S36/COM4	D106	D107	D108

Note) S36/COM4 pin is selected segment output.

For example, the table below lists the output states for the S21 output pin.

Display data			Output pin (S21) state
D61	D62	D63	
0	0	0	The LCD segments corresponding to COM1, COM2 and COM3 are off.
0	0	1	The LCD segment corresponding to COM3 is on.
0	1	0	The LCD segment corresponding to COM2 is on.
0	1	1	The LCD segments corresponding to COM2 and COM3 are on.
1	0	0	The LCD segment corresponding to COM1 is on.
1	0	1	The LCD segments corresponding to COM1 and COM3 are on.
1	1	0	The LCD segments corresponding to COM1 and COM2 are on.
1	1	1	The LCD segments corresponding to COM1, COM2 and COM3 are on.

LC75805PE

(3) Correspondence of output pins to display data for LCD at 1/2 Duty Drive

Output Pin	COM1	COM2	Output Pin	COM1	COM2
S1	D1	D2	S20	D39	D40
S2	D3	D4	S21	D41	D42
S3	D5	D6	S22	D43	D44
S4	D7	D8	S23	D45	D46
S5	D9	D10	S24	D47	D48
S6	D11	D12	S25	D49	D50
S7	D13	D14	S26	D51	D52
S8	D15	D16	S27	D53	D54
S9	D17	D18	S28	D55	D56
S10	D19	D20	S29	D57	D58
S11	D21	D22	S30	D59	D60
S12	D23	D24	S31	D61	D62
S13	D25	D26	S32	D63	D64
S14	D27	D28	S33	D65	D66
S15	D29	D30	S34	D67	D68
S16	D31	D32	S35	D69	D70
S17	D33	D34	S36/COM4	D71	D72
S18	D35	D36	S37/COM3	D73	D74
S19	D37	D38			

Note) S36/COM4 and S37/COM3 pins are selected segment output.

For example, the table below lists the output states for the S21 output pin.

Display data		Output pin (S21) state
D41	D42	
0	0	The LCD segments corresponding to COM1 and COM2 are off.
0	1	The LCD segment corresponding to COM2 is on.
1	0	The LCD segment corresponding to COM1 is on.
1	1	The LCD segment corresponding to COM1 and COM2 are on.

LC75805PE

(4) Correspondence of output pins to display data for LCD at Static Drive (1/1 Duty Drive)

Output Pin	COM1	Output Pin	COM1
S1	D1	S21	D21
S2	D2	S22	D22
S3	D3	S23	D23
S4	D4	S24	D24
S5	D5	S25	D25
S6	D6	S26	D26
S7	D7	S27	D27
S8	D8	S28	D28
S9	D9	S29	D29
S10	D10	S30	D30
S11	D11	S31	D31
S12	D12	S32	D32
S13	D13	S33	D33
S14	D14	S34	D34
S15	D15	S35	D35
S16	D16	S36/COM4	D36
S17	D17	S37/COM3	D37
S18	D18	S38/COM2	D38
S19	D19		
S20	D20		

Note) S36/COM4, S37/COM3 and S38/COM2 pins are selected segment output.

For example, the table below lists the output states for the S21 output pin.

Display data	Output pin (S21) state
D21	
0	The LCD segment to COM1 is off.
1	The LCD segment to COM1 is on.

LC75805PE

Correspondence of output pins to display data for LED

Output Pin	Display data	Output Pin	Display data
LD1	LT1	LD25	LT25
LD2	LT2	LD26	LT26
LD3	LT3	LD27	LT27
LD4	LT4	LD28	LT28
LD5	LT5	LD29	LT29
LD6	LT6	LD30	LT30
LD7	LT7	LD31	LT31
LD8	LT8	LD32	LT32
LD9	LT9	LD33	LT33
LD10	LT10	LD34	LT34
LD11	LT11	LD35	LT35
LD12	LT12	LD36	LT36
LD13	LT13	LD37	LT37
LD14	LT14	LD38	LT38
LD15	LT15	LD39	LT39
LD16	LT16	LD40	LT40
LD17	LT17	LD41	LT41
LD18	LT18	LD42	LT42
LD19	LT19	LD43	LT43
LD20	LT20	LD44	LT44
LD21	LT21	LD45	LT45
LD22	LT22	LD46	LT46
LD23	LT23	LD47	LT47
LD24	LT24	LD48	LT48

For example, the table below lists the output states for the LD21 output pin.

Display data	Output pin (LD21) state
LT21	
0	LED is off. (High impedance output)
1	<p>LED is on.</p> <p>Note) If (L21A, L21B, L21C) = (0, 0, 0) is set, the LED by 100% duty is on.</p> <p>If (L21A, L21B, L21C) = (1, 0, 0) is set, the LED depending on the contents of PWM data, W10 to W16, of PWM circuit (Ch1) is on.</p> <p>If (L21A, L21B, L21C) = (0, 1, 0) is set, the LED depending on the contents of PWM data, W20 to W26, of PWM circuit (Ch2) is on.</p> <p>If (L21A, L21B, L21C) = (1, 1, 0) is set, the LED depending on the contents of PWM data, W30 to W36, of PWM circuit (Ch3) is on.</p> <p>If (L21A, L21B, L21C) = (0, 0, 1) is set, the LED depending on the contents of PWM data, W40 to W46, of PWM circuit (Ch4) is on.</p> <p>If (L21A, L21B, L21C) = (1, 0, 1) is set, the LED depending on the contents of PWM data, W50 to W56, of PWM circuit (Ch5) is on.</p> <p>If (L21A, L21B, L21C) = (0, 1, 1) is set, the LED depending on the contents of PWM data, W60 to W66, of PWM circuit (Ch6) is on.</p> <p>If (L21A, L21B, L21C) = (1, 1, 1) is set, the LED depending on the contents of PWM data, W70 to W76, of PWM circuit (Ch7) is on.</p>

LC75805PE

LCD drive waveform (1/4-Duty 1/3-Bias drive, Frame inversion drive)

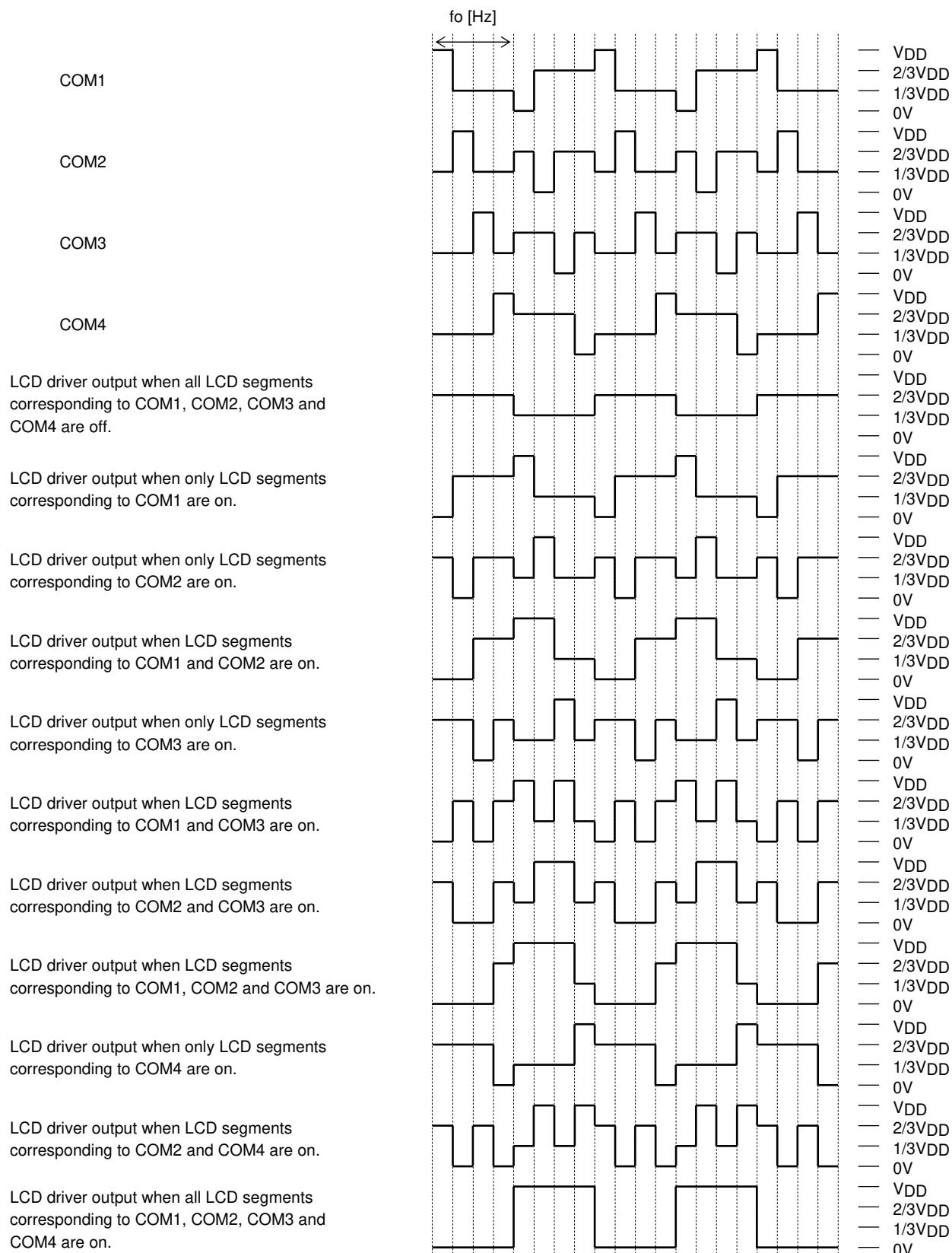

LC75805PE

LCD drive waveform (1/3-Duty 1/3-Bias drive, Frame inversion drive)

